

CLD156

Large Active Area Silicon Planar photodiode

This product is tested to satisfy the conditions of both the CLD156 and the CLD156R.



May, 2001

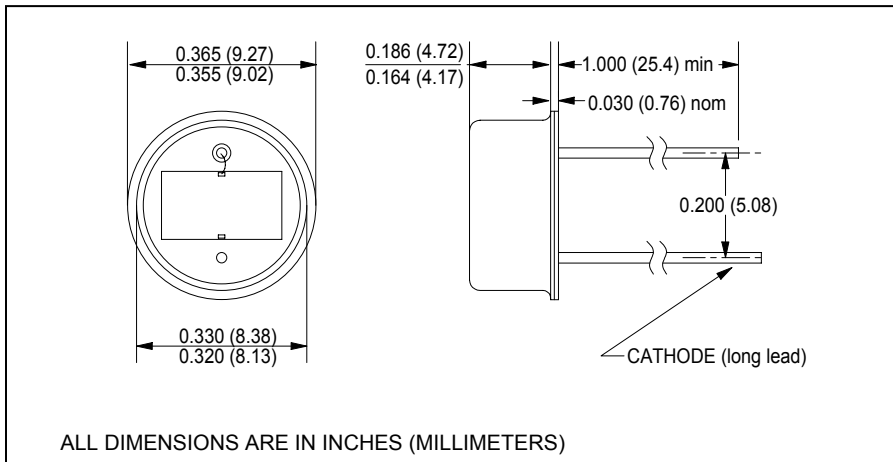

features

- 100° acceptance angle
- 860nm peak response
- TO-5 hermetic package
- usable for visible through near-IR
- RoHS compliant

absolute maximum ratings ($T_A = 25^\circ\text{C}$ unless otherwise stated)

storage temperature.....	-65°C to +150°C
operating temperature.....	-65°C to +150°C
lead soldering temperature ⁽¹⁾	260°
reverse voltage.....	30V
continuous power dissipation ⁽²⁾	200mW

description

The CLD156 and CLD156R are 0.122" x 0.222" active area silicon photodiodes featuring high linearity and low dark current. The TO-5 header provides thermal environment for reliable operation over a wide temperature range. Wide acceptance angle permits use in IR air communications, ambient light detection, safety and monitoring, security systems, etc. For additional information, call Clairex.

notes:

1. 0.06" (1.5mm) from the header for 5 seconds maximum.
2. Derate linearly 1.28mW/°C free air temperature to $T_A = +150^\circ\text{C}$.

electrical characteristics ($T_A = 25^\circ\text{C}$ unless otherwise noted)						
symbol	parameter	min	typ	max	units	test conditions
I_{SC}	Short-circuit current ⁽³⁾	-	100	-	μA	$V_{BIAS} = 0\text{V}$, $E_e = 5\text{mW}/\text{cm}^2$
I_D	Dark current	-	-	50	nA	$V_F = 100\text{mV}$, $E_e = 0$
		-	-	50	nA	$V_R = 15\text{V}$, $E_e = 0$
V_O	Open circuit voltage ⁽³⁾	-	0.35	-	V	$E_e = 5\text{mW}/\text{cm}^2$
V_{BR}	Reverse breakdown	25	-	-	V	$I_R = 100\mu\text{A}$
C_J	Junction capacitance	-	-	400	pF	$V_{BIAS} = 0\text{V}$, $f = 1\text{MHz}$
t_r, t_f	Output rise and fall time ⁽⁴⁾	-	-	10	μs	$R_L = 1\text{k}\Omega$
Θ_{HP}	Total angle at half sensitivity points	-	100	-	deg.	

notes: 3. Radiation source is a frosted tungsten lamp at a color temperature of 2854K or equivalent.

4. Radiation source is an AlGaAs IRED operating at a peak emission wavelength of 880nm and $E_e = 20\text{mW}/\text{cm}^2$.

Clairex reserves the right to make changes at any time to improve design and to provide the best possible product.

Revised 3/15/06