

CFE320A

Fiber Optic AlGaAs IRED

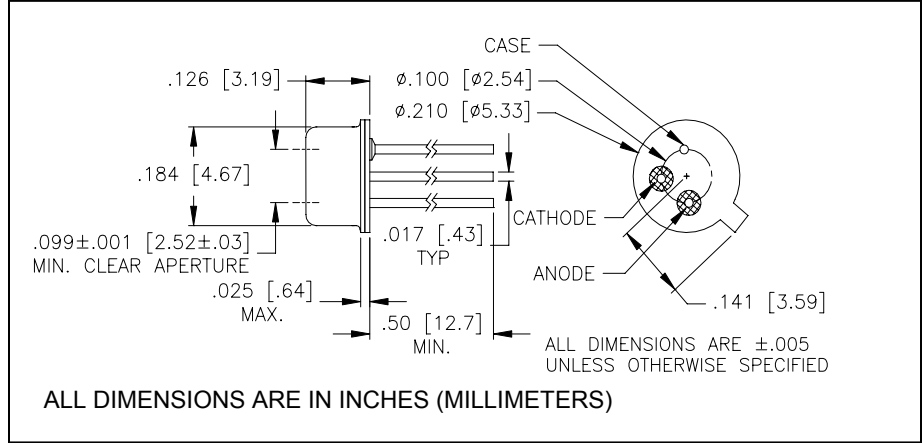

November, 2004



features

- Electrically isolated from case
- High speed
- Optimized for fiber optic applications
- TO-46 header, flat window can
- RoHS compliant

absolute maximum ratings ($T_A = 25^\circ\text{C}$ unless otherwise stated)

storage temperature	-55°C to +150°C
operating temperature.....	-55°C to +125°C
lead soldering temperature ⁽¹⁾	260°C
reverse voltage	5VDC
continuous forward current ⁽²⁾⁽³⁾	100mA

description

The CFE320A is intended for use in fiber-optic systems and contains an 850nm AlGaAs IRED mounted on a TO-46 header. Features are high coupled power and fast rise and fall times in an easily mounted hermetic package. A glass microlens is mechanically centered over the IRED to enhance light coupling.

notes:

1. 1/16" (1.6mm) from case for 5 seconds maximum.
2. Derate linearly 0.80mA/°C from 25°C free air temperature to $T_A = +125^\circ\text{C}$.
3. Continuous operation at this current level requires a heat sink.

electrical characteristics ($T_A = 25^\circ\text{C}$, unless otherwise noted)						
symbol	parameter	min	typ	max	units	test conditions
P_O	Total power output ⁽³⁾	15	19	-	μW	$I_F = 100\text{mA}$
V_F	Forward voltage	-	1.8	2.2	V	$I_F = 100\text{mA}$
λ_P	Peak emission wavelength	830	850	870	nm	$I_F = 100\text{mA}$
BW	Spectral bandwidth at half power points	-	35	-	nm	$I_F = 100\text{mA}$
t_r	Output rise time	-	5.0	8.0	ns	$I_F = 100\text{mA}$, 10% - 90% ⁽⁴⁾
t_f	Output fall time	-	5.0	10	ns	$I_F = 100\text{mA}$, 10% - 90% ⁽⁴⁾

- notes: 3. Graded index fiber, 50 μm core, N.A. = 0.20.
4. Prebias at 5mA.

Clairex reserves the right to make changes at any time to improve design and to provide the best possible product.

Revised 3/15/06

Clairex Technologies, Inc.
Phone: 972-265-4900

1301 East Plano Parkway
Fax: 972-265-4949

Plano, Texas 75074-8524
www.clairex.com