

MAS6502

Piezoresistive Sensor Signal Interface IC

- **Optimized for Piezoresistive Pressure Sensors**
- **Very Low Power Consumption**
- **Ratiometric 16 Bit $\Delta\Sigma$ ADC**
- **Linearity 14 Bits**
- **Internal Clock Oscillator**
- **Serial Data Interface (I²C[®] Bus)**
- **256 Bit EEPROM Memory**

DESCRIPTION

MAS6502 is a 16 bit Analog-to-Digital Converter (ADC), which employs a delta-sigma ($\Delta\Sigma$) conversion technique. With the linear input signal range of 260 mV_{PP} the linearity is 14 bits.

MAS6502 is designed especially to meet the requirement for low power consumption, thus making it an ideal choice for battery powered systems. The MAS6502 is equipped with a standby function, i.e. the ADC is in power down between each conversion. By utilizing this and overall low power consumption, current consumption values of 2.5 μ A (one pressure conversion in a second with full 14-bit accuracy) or less can be achieved.

MAS6502 has an on-chip second order decimator filter to process the output of the second order $\Delta\Sigma$ -modulator. The ADC also has four

selectable input signal ranges with one optional offset level. An internal trimmed clock oscillator provides a system clock signal (DCLK) eliminating the need for an external clock signal.

A bi-directional I²C[®] bus compatible 2-wire serial bus is used for configuring conversion parameters, starting conversion and reading out the A/D conversion result.

MAS6502 has one input channel suitable for a piezoresistive pressure sensor. In addition to pressure measurement the device can be configured also for temperature measurement.

The 256-bit EEPROM memory is available for storing trimming and calibration data on chip.

FEATURES

- Low Standby Current Consumption 0.05 μ A Typ
- Very Low Supply Current: 0.4 μ A...2.5 μ A Typ
- Supply Voltage: 2.0 V...3.6 V
- Ratiometric $\Delta\Sigma$ Conversion
- Selectable Input Signal Ranges (VDD=2.35V):
 - 325 mV_{PP}, 220 mV_{PP}, 150 mV_{PP}, 100 mV_{PP}
- Selectable Optional Offset (VDD=2.35V):
 - 33 mV
- Selectable Sensor Resistance Values
 - 5 k Ω , 4.5 k Ω , 4 k Ω , 3.4 k Ω
- Over Sampling Ratio: 512, 256, 128, 64
- Internal System Clock Signal 100 kHz
- Conversion Times 0.8 ms...10.6 ms Typ
- 2-Wire Serial Data Interface (I²C[®] Bus)
- 256 Bit EEPROM Memory
- Good Noise Performance due to $\Delta\Sigma$ Architecture

APPLICATIONS

- Calibrated Piezoresistive Pressure Modules
- Temperature measurement
- Battery Powered Systems
- Low Frequency Measurement Applications
- Current/Power Consumption Critical Systems
- Industrial and Process Control Applications in Noisy Environments

I²C is a registered trademark of NXP.

BLOCK DIAGRAM

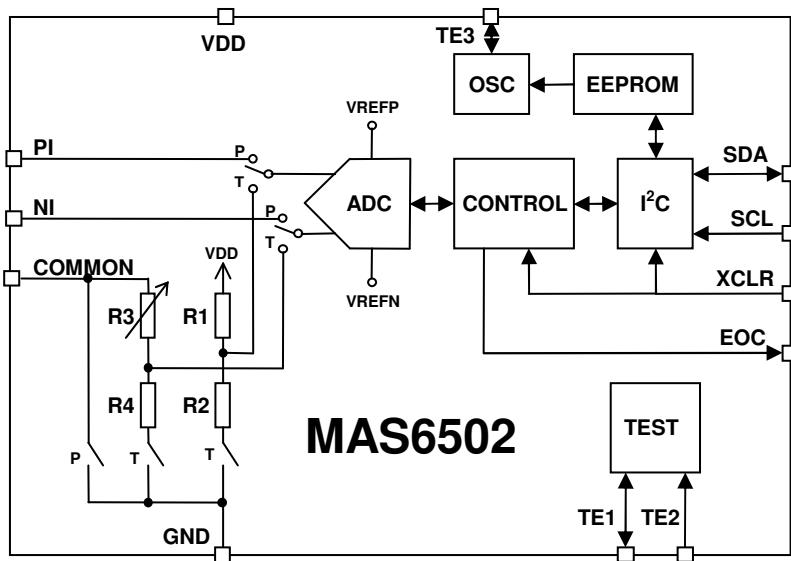

Figure 1. MAS6502 block diagram

ABSOLUTE MAXIMUM RATINGS

All Voltages with Respect to Ground

Parameter	Symbol	Conditions	Min	Max	Unit
Supply Voltage	V_{DD}		-0.3	5.0	V
Voltage Range for All Pins			-0.3	$V_{IN} + 0.3$	V
Latchup Current Limit	I_{LUT}	For all pins, test according to JESD78A.	-100	+100	mA
Junction Temperature	T_{Jmax}			+ 150	°C
Storage Temperature	T_S	Note 1	- 55	+125	°C

Note 1. See EEPROM memory data retention at hot temperature. Storage or bake at hot temperatures will reduce the wafer level trimming and calibration data retention time.

Note: The absolute maximum rating values are stress ratings only. Functional operation of the device at conditions between maximum operating conditions and absolute maximum ratings is not implied and EEPROM contents may be corrupted. Exposure to these conditions for extended periods may affect device reliability (e.g. hot carrier degradation, oxide breakdown). Applying conditions above absolute maximum ratings may be destructive to the devices.

Note: This is a CMOS device and therefore it should be handled carefully to avoid any damage by static voltages (ESD).

RECOMMENDED OPERATION CONDITIONS

Parameter	Symbol	Conditions	Min	Typ	Max	Unit
Supply Voltage	V_{DD}		2.0	2.35	3.6	V
Supply Voltage at EEPROM Programming	V_{DD}	$T=+25^{\circ}\text{C}$. Note 1.	3.0	3.3	3.6	V
Operating Temperature	T_A		-40	+25	+85	°C

The device performance may deteriorate in the long run if the Recommended Operation Conditions limits are continuously exceeded.

Note 1. It is recommended to program the EEPROM at room temperature.

ELECTRICAL CHARACTERISTICS
 $T_A = -40^{\circ}\text{C}$ to $+85^{\circ}\text{C}$, $V_{DD} = 2.0\text{V}$ to 3.6V , $T_{yp} T_A = 27^{\circ}\text{C}$, $T_{yp} V_{DD} = 2.35\text{V}$, $R_{\text{sensor}} = 4.5\text{k}\Omega$ unless otherwise noted

Parameter	Symbol	Conditions	Min	Typ	Max	Unit
Average ADC Current during Conversion Time	I_{CONV}	Pressure mode Temperature mode	80 100	185 200	330 350	μA
Average ADC Current in Pressure Measurement during Conversion Period (no sensor current included)	I_{ADC_P}	1 conversion/s, $R_{\text{sensor}} = 4.5\text{k}\Omega$, OSR=512 OSR=256 OSR=128 OSR=64	0.4 0.2 0.1 0.06	1.0 0.5 0.3 0.15	1.7 0.9 0.5 0.26	μA
Average ADC Current in Temperature Measurement during Conversion Period (no sensor current included)	I_{ADC_T}	1 conversion/s, $R_{\text{sensor}} = 4.5\text{k}\Omega$, OSR=512 OSR=256 OSR=128 OSR=64	0.8 0.4 0.2 0.1	2.0 1.0 0.5 0.3	3.5 1.8 0.95 0.5	μA
Average Supply Current in Pressure Measurement during Conversion Period (including sensor bridge current)	I_{SAVG_P}	1 conversion/s, $R_{\text{sensor}} = 4.5\text{k}\Omega$, OSR=512 OSR=256 OSR=128 OSR=64	1.8 0.95 0.5 0.3	2.4 1.2 0.7 0.4	3.1 1.6 0.9 0.5	μA
Average Supply Current in Temperature Measurement (including sensor bridge current)	I_{SAVG_T}	1 conversion/s, $R_{\text{sensor}} = 4.5\text{k}\Omega$, OSR=512 OSR=256 OSR=128 OSR=64	1.4 0.7 0.4 0.2	2.5 1.3 0.7 0.4	4.0 2.1 1.1 0.6	μA
Peak Supply Current During Pressure Measurement	I_{SC_P}	$V_{DD} = 2.35\text{V}$, $R_{\text{sensor}} = 4.5\text{k}\Omega$	0.6	0.7	0.85	mA
Peak Supply Current During Temperature Measurement	I_{SC_T}	$V_{DD} = 2.35\text{V}$, $R_{\text{sensor}} = 4.5\text{k}\Omega$	0.2	0.3	0.46	mA
Standby Current	I_{SS}	$V_{DD} = 2.35\text{V}$ Note 1.		0.05	0.5	μA
Internal System Clock Frequency	DCLK	Pressure measurement Temperature measurement	85 42.5	100 50	113 56.5	kHz
Pressure Conversion Time	t_{CONV_P}	DCLK = 100 kHz, OSR=512 OSR=256 OSR=128 OSR=64	4.6 2.4 1.2 0.7	5.3 2.7 1.5 0.8	6.2 3.2 1.7 0.95	ms
Temperature Conversion Time	t_{CONV_T}	DCLK = 50 kHz, OSR=512 OSR=256 OSR=128 OSR=64	9.3 4.8 2.5 1.4	10.6 5.5 2.9 1.6	12.4 6.4 3.4 1.9	ms
VDD Rise Time for Proper Power On Reset (POR)	$t_{\text{VDD_RISE}}$	Note 2.			400	ns

 Note 1. Leakage current may increase if digital input voltages are not close to V_{DD} (logic level high) or GND (logic level low)

 Note 2. Device reset by using XCLR pin or reset register (30_{HEX}) is necessary in case the V_{DD} rise time is longer than specified here.

ELECTRICAL CHARACTERISTICS

 $T_A = -40^{\circ}\text{C}$ to $+85^{\circ}\text{C}$, $V_{DD} = 2.0\text{V}$ to 3.6V , $T_{yp} T_A = 27^{\circ}\text{C}$, $T_{yp} V_{DD} = 2.35\text{V}$, $R_{\text{sensor}} = 4.5\text{k}\Omega$ unless otherwise noted

Parameter	Symbol	Conditions	Min	Typ	Max	Unit
Resolution	N_{BIT}			16		Bit
	V_{LSB}	OSR=512 ISR = 325 mV ISR = 100 mV Note 1.		5 1.5		μV
Noise (one sigma)	V_{N}	OSR=512, ISR = 325 mV, VDD=3.3V		3.4		μV_{RMS}
				0.68		LSB
Accuracy		OSR = 512, $T_A = 27^{\circ}\text{C}$ ISRLIN = 260 mV		± 20		μV
Integral Nonlinearity	INL	OSR=512, VDD = 2.35V, $T_A = 27^{\circ}\text{C}$ ISRLIN = 260 mV ISRLIN = 100 mV Note 2.		± 2.7 ± 6.2	$\pm 6^{1)}$ $\pm 14^{1)}$	LSB
VDD Sensitivity in Pressure Mode	VDDSENSP	Pressure mode, OSR=512, ISR = 325mV, $T_A = 27^{\circ}\text{C}$ VDD step 3.6V \Rightarrow 2.0V		± 15	± 40	LSB
VDD Sensitivity in Temperature Mode	VDDSENST	Temperature mode, OSR=512, ISR = 325mV, $T_A = 27^{\circ}\text{C}$ VDD step 3.6V \Rightarrow 2.0V		± 80	± 150	LSB
Linearity in Bits	LIN	ISRLIN = 260 mV, $T_A = 27^{\circ}\text{C}$ OSR=512 OSR=256 OSR=128 OSR=64 Note 3.		14 13 12 10		Bit
Input Signal Range	ISR	ISR=325 ISR=220 ISR=150 ISR=100	306 207 140 92	312 211 144 96	318 215 148 100	mV
Linear Input Signal Range	ISRLIN	Note 4.		260 176 120 80		mV
Input Signal Offset	OFFSET	+33mV selection No offset selection		33 0		mV
Output Code Values	CODE	OSR=512 OSR=256 OSR=128 OSR=64	0 0 0 0		65152 32385 8001 1953	

1) Guaranteed by design

Note 1. ISR (ISRLIN) and OSR refer to the ADC control register bits, see table 2 on page 8.

Note 2. Integral nonlinearity calculated from best fit line to linear input signal range containing 21pcs analysis points.

 Note 3. Linearity in bits calculated from $LIN = \log[(CODE_{\text{LIN_MAX}} - CODE_{\text{LIN_MIN}}) / INL] / \log(2) \approx \log(83\% * CODE_{\text{MAX}} / INL) / \log(2)$

Note 4. ISR typ linear range guaranteed by linearity testing

ELECTRICAL CHARACTERISTICS

$T_A = -40^{\circ}\text{C}$ to $+85^{\circ}\text{C}$, $V_{DD} = 2.0\text{V}$ to 3.6V , $T_{yp} T_A = 27^{\circ}\text{C}$, $T_{yp} V_{DD} = 2.35\text{V}$, $R_{\text{sensor}} = 4.5\text{k}\Omega$ unless otherwise noted

Parameter	Symbol	Conditions	Min	Typ	Max	Unit
Temperature Measurement Resistors	R_1		-19%	13900	+19%	Ω
	R_2 R_4			30600 30600		
	R_3	$R_{\text{sensor}} = 5\text{ k}\Omega$ $R_{\text{sensor}} = 4.5\text{ k}\Omega$ $R_{\text{sensor}} = 4\text{ k}\Omega$ $R_{\text{sensor}} = 3.4\text{ k}\Omega$	-19%	8900 9400 9900 10500	+19%	Ω
Temperature Coefficient of Temperature Measurement Resistors	TC_R			-180		ppm / $^{\circ}\text{C}$
EEPROM size		Note 1.		256		bit
EEPROM data write time		Note 2.			16	ms
EEPROM data erase time		Note 3.			8	ms
EEPROM data retention		$T_A = +85^{\circ}\text{C}$ $T_A = +125^{\circ}\text{C}$	10	24 1		years

Note 1. 8 bits out of 256 bits are reserved for internal oscillator trimming. The remaining 248 bits can be freely used for storing calibration coefficients and other data.

Note 2. There should be at least a 16ms delay after each EEPROM write since EEPROM programming can take up to 16ms.

Note 3. There should be at least a 8ms delay after each EEPROM erase since EEPROM erasing can take up to 8ms.

Digital inputs

$T_A = -40^{\circ}\text{C}$ to $+85^{\circ}\text{C}$, $V_{DD} = 2.0\text{V}$ to 3.6V , $T_{yp} T_A = 27^{\circ}\text{C}$, $T_{yp} V_{DD} = 2.35\text{V}$, $R_P = 4.7\text{k}\Omega$ ($I^2\text{C}$ bus pull up) unless otherwise noted

Parameter	Symbol	Conditions	Min	Typ	Max	Unit
Input High Voltage	V_{IH}		80% VDD		100% VDD	V
Input Low Voltage	V_{IL}		0% VDD		20% VDD	V
Serial Bus Clock Frequency	f_{SCL}				400	kHz
XCLR Reset Pulse Length	t_{XCLR}	XCLR low pulse	200			ns
XCLR Pin Pull Up Current	I_{PULL_UP}	XCLR=0V	-1	-8	-80	μA

Digital outputs

$T_A = -40^{\circ}\text{C}$ to $+85^{\circ}\text{C}$, $V_{DD} = 2.0\text{V}$ to 3.6V , $T_{yp} T_A = 27^{\circ}\text{C}$, $T_{yp} V_{DD} = 2.35\text{V}$, $R_P = 4.7\text{k}\Omega$ ($I^2\text{C}$ bus pull up) unless otherwise noted

PARAMETER	SYMBOL	CONDITIONS	MIN	TYP	MAX	UNIT
Output high voltage	V_{OH}	$I_{\text{Source}}=0.6\text{mA}$	80% VDD		100% VDD	V
Output low voltage	V_{OL}	$I_{\text{Sink}}=0.6\text{mA}$	0% VDD		20% VDD	V
Signal rise time (from 10% to 90%)	t_r	EOC pin, $C_L=50\text{pF}$ SDA pin, $C_B=50\text{pF}$		14 550		ns
Signal fall time (from 90% to 10%)	t_f	EOC pin, $C_L=50\text{pF}$ SDA pin, $C_B=50\text{pF}$		11 11		ns

OPERATING MODES

MAS6502 has two operating modes, pressure and temperature measurement mode. In the pressure mode the pressure dependent sensor bridge voltage is connected to the ADC input. In the temperature measurement mode the resistive sensor is connected into a Wheatstone resistor bridge circuit together with four internal resistors (see Temperature Measurement Configuration in the Application Information chapter) and the temperature dependent bridge output voltage is connected to the ADC input.

Switching between pressure and temperature measurement modes is done via the single ADC control register. The measurement configuration includes selection of over sampling ratio, input signal range, offset and sensor resistance. By writing an 8-bit configuration data to the ADC control register a new A/D conversion is started. See further details in the ADC Control Register chapter.

MAS6502 includes a 256-bit EEPROM memory for storing trimming and calibration data on chip. The first 8-bits of EEPROM are reserved for internal oscillator trimming but the remaining 248-bits are free for calibration and other data.

The stored calibration data should comprise of calibration and temperature compensation coefficients which can be used to calculate accurate calibrated pressure and temperature measurement results from the non-calibrated measurement results. All calculations need to be done in the external micro controller unit (MCU).

A calibrated MAS6502 sensor system is operated as illustrated in figure 2. The calibration and compensation coefficients need to be read to the MCU memory only once. From each pair of pressure and temperature measurements results the accurate pressure and temperature values are then calculated by using the external MCU.

All communication with MAS6502 is done using the bi-directional I²C[®] bus compatible 2-wire serial bus. Starting an A/D conversion, reading out the conversion result and reading and writing data from and to the EEPROM memory are all accomplished via serial bus communication.

In addition to the I²C[®] bus the digital interface includes also end-of-conversion (EOC) and master reset (XCLR) pins. See A/D Conversion in the Serial Data Interface (I²C[®] Bus) Control chapter.

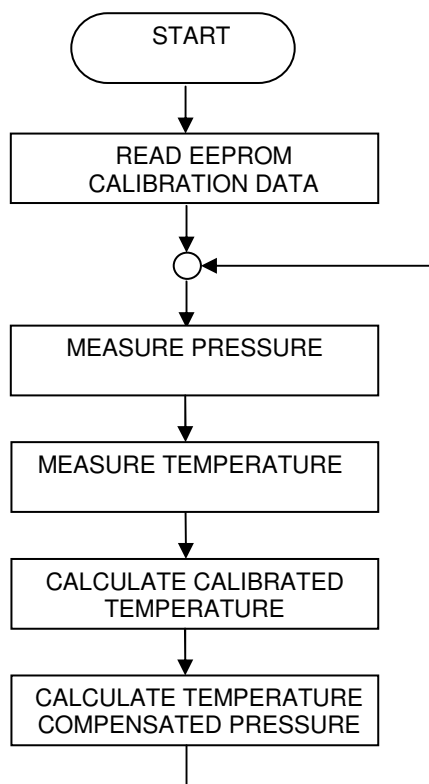

Figure 2. Flow chart for a calibrated MAS6502 sensor system

REGISTER AND EEPROM DATA ADDRESSES

MAS6502 includes a 32 bytes (256 bits) EEPROM data memory. The first EEPROM byte at address 40_{HEX} is reserved for internal clock oscillator frequency trimming. The remaining 31 bytes (248 bits) in memory addresses 41_{HEX} ...5F_{HEX} are free

for storing sensor calibration and other data. MAS6502 also contains ten 8-bit registers. Writing any dummy data to the reset register triggers device reset. See table 1 for register and EEPROM data addresses.

Table 1. Register and EEPROM data addresses

A7	A6	A5	A4	A3	A2	A1	A0	HEX (X=0)	Description	Note
X	0	0	0	0	0	0	0	00	EEPROM; erase internal clock oscillator trimming, reserved!	E
X	0	0	A4	A3	A2	A1	A0	01...1F	EEPROM; erase data at address [A4:A0]	E
X	1	0	0	0	0	0	0	40	EEPROM; read or write internal clock oscillator trimming, reserved!	E
X	1	0	A4	A3	A2	A1	A0	41...5F	EEPROM; read or write data at address [A4:A0]	E
X	X	1	1	0	0	0	0	30	Reset register; contains no data, write any dummy data for a reset	R
X	X	1	1	0	1	1	1	37	Test and trim control register	R
X	X	1	1	1	0	0	0	38	Oscillator frequency control register	R
X	X	1	1	1	0	0	1	39	Data input register for EEPROM	R
X	X	1	1	1	0	1	0	3A	Control register for EEPROM	R
X	X	1	1	1	0	1	1	3B	Write and erase enable for EEPROM	R
X	X	1	1	1	1	0	0	3C	Status register for EEPROM	R
X	X	1	1	1	1	0	1	3D	MSB conversion result	R
X	X	1	1	1	1	1	0	3E	LSB conversion result	R
X	X	1	1	1	1	1	1	3F	ADC control register	R

X = Don't care, E = EEPROM, R= Register

EEPROM addresses 01_{HEX} ...1F_{HEX} are used for erasing the data at the addressed bytes whereas EEPROM addresses 41_{HEX} ...5F_{HEX} are for read/write of addressed bytes. In case of writing the data the EEPROM address or block when necessary is erased automatically before writing new data on it. There should be at least a 16ms delay after each EEPROM write since EEPROM programming can take up to 16ms. For EEPROM erase this delay should be at least 8ms.

Reset register (30_{HEX}) does not contain any data. Any dummy data written to this register forces a reset. A reset initializes all control registers (addresses 37_{HEX}...3F_{HEX}) to a zero value.

Test and trim control register (37_{HEX}) is for testing and trimming purposes.

The oscillator frequency control register (38_{HEX}) is used only during internal clock oscillator trimming. During trimming this register value is iterated to find desired oscillator frequency. When the correct value is found it can be written to the EEPROM internal clock oscillator trimming register (40_{HEX}). In normal operation the trimming value is automatically read from the EEPROM memory during startup. **Note:**

There is no need for internal oscillator trimming since this is done during wafer level testing.

EEPROM data input register (39_{HEX}) is automatically used in all EEPROM data transfers. There is no need to address this register manually except when doing a "block write" when data must be written to the input register before giving the block write command. EEPROM control register (3A_{HEX}) is for special EEPROM functions like block erase, block write and test modes.

The EEPROM write and erase enable register (3B_{HEX}) is used to protect the calibration memory against accidental write/erase. After reset (power on reset, XCLR) this register is set to %00000000 (00_{HEX}) and the EEPROM memory erase/write is disabled. The EEPROM erase/write is enabled only when this register value is set to %01010101 (55_{HEX}). EEPROM status register (3C_{HEX}) is used for EEPROM error correction status.

The MSB and LSB conversion result registers (3D_{HEX} and 3E_{HEX}) contain the last 16-bit A/D conversion result. The ADC control register (3F_{HEX}) is used for configuring and starting A/D conversions. See chapter ADC Control Register for details.

ADC CONTROL REGISTER

Table 2. MAS6502 ADC control register bit description

Bit Number	Bit Name	Description	Value	Function
7-6	OSRS	Over Sampling Ratio (OSR) selection	11	OSR = 512
			01	OSR = 256
			10	OSR = 128
			00	OSR = 64
5	PTS	Pressure/Temperature Selection	1 0	Pressure Measurement Temperature Measurement
4-3	ISR	Input Signal Range	11	325 mV (260 mV linear range)
			10	220 mV (176 mV linear range)
			01	150 mV (120 mV linear range)
			00	100 mV (80 mV linear range)
2	OSSELECT	Offset Selection	1 0	+33 mV No offset
1-0	RSSELECT	Sensor Resistance Selection for Temperature Measurement Mode	11	Rsensor = 3.4 k Ω
			10	Rsensor = 4.0 k Ω
			01	Rsensor = 4.5 k Ω
			00	Rsensor = 5.0 k Ω

MAS6502 has an ADC control register for configuring the measurement setup. A new conversion is started simply by writing 8-bit configuration data to the ADC control register. See table 2 for ADC control register bit definitions. ADC control register values are set via the 2-wire serial data interface. **Note:** The device should not be addressed via serial bus before the conversion has been ended. Reading or writing to device during the conversion may corrupt the conversion result.

The first two OSRS bits of the control register defines four selectable over sampling ratios. The higher the OSR is set the better is the ADC resolution, but the conversion time gets longer.

The PTS bit selects between pressure and temperature measurement. For temperature measurement the sensor is connected in the Wheatstone bridge configuration together with four integrated resistors. See figure 5 on page 15.

The ISR bits selects between four A/D input signal ranges.

The OSSELECT bit is used to enable or disable an offset for the input signal.

The two RSSELECT bits selects between four sensor resistance options. The selection sets the internal R3 resistor value to balance the Wheatstone bridge circuit formed by the sensor resistance and four internal resistors R1, R2, R3 and R4. See Electrical Characteristics for resistor values.

TEST AND TRIM CONTROL REGISTER

Pins TE1 (output), TE2 (input) and TE3 (input/output) are used for testing purposes. In normal use these pins are left floating.

TE2=0: normal operation, (pull down resistor on chip). TE1 is driven high.

TE2=1: the converter is in continuous integration mode. The sigma - delta modulator latch output is connected to the TE1 pin and TE1 is also connected to the on-chip decimator input. This way an external decimator can use the TE1 pin signal and the results from the external and the on-chip decimator can be compared.

Oscillator trimming: Test register REG37_{HEX} bit 0 (MEASOSC) turns the oscillator on and connects the oscillator output to the TE3 pin for frequency measurement.

REG37_{HEX} bit 2 (TRIMALLREG) is used for oscillator trimming. When set to 1, the six least significant bits OSCF(5:0) in REG38_{HEX} are used to adjust the oscillator frequency (see table 4). When the right frequency is obtained the trim value can be

programmed to the EEPROM (address 40_{HEX}). The nominal frequency, 200kHz, is designed to occur when OSCF(5:0) = 28_{HEX}. **Note: There is no need for internal oscillator trimming since this is done during wafer level testing.**

If TRIMALLREG=0 then data from EEPROM address 40_{HEX} will be used to adjust the oscillator.

When bit 1 (EXTCLK) in test register REG37_{HEX} is set to 1 the internal oscillator is turned off and an external clock signal can be connected to the TE3 pin. This enables the use of an external conversion clock.

Test register REG37_{HEX} bit 4 (ICLKDIV) enables clock division, forcing the A/D conversion to run at half the speed. Clock division is also used when an external clock is used (EXTCLK bit is set).

Test register REG37_{HEX} bit 3 (ISAMPL) enables refreshing sensor sample only at every fourth clock cycle for additional power saving but with increased sampling noise level.

Table 3. MAS6502 test and trim control register (37_{HEX}). Only bits (4:0) are used.

Bit Number	Bit Name	Description	Value	Function
7...5			X	-
4	ICLKDIV	Additional clock division	0 1	100kHz/50kHz to SDM 50kHz/25kHz to SDM
3	ISAMPL	Sample refresh mode selection	0 1	Refresh at every clock cycle Refresh at fourth clock cycle
2	TRIMALLREG	Trim bits from register	0 1	Normal operation OSC trim register in use
1	EXTCLK	External clock mode	0 1	Normal operation External clock from TE3
0	MEASOSC	Oscillator test mode	0 1	Normal operation OSC output to TE3

X = Don't care, SDM = Sigma delta modulator

Table 4. MAS6502 oscillator frequency control register (38_{HEX}). Only bits (5:0) are used.

Bit Number	Bit Name	Description	Value	Function
7...6			X	-
5...0	OSCF		11111 ... 00000	200kHz oscillator frequency trimming value

X = Don't care

Note: It is recommended to not change oscillator frequency trimming value since trimming is done during wafer level testing.

EEPROM SPECIAL FUNCTIONS

Register (3A_{HEX}) controls the special EEPROM functions that includes EEPROM block erase, write and test functions. See table 5. The EEPROM control register functions are not needed in normal EEPROM use such as read and write operations.

The 256-bit EEPROM consists of two 128-bit blocks, so block erase and block write applies only to one half of the EEPROM, selectable by the A4 address bit (see table 1). To erase or write the whole EEPROM, block erase or write needs to be done twice: for A4=0 and for A4=1. It is recommended to not use block erase or write functions to avoid accidental internal oscillator trimming data overwriting at A4=0 memory block.

Setting the EEPROM control register bit 7 (EBE) to 1 will erase the EEPROM memory block (128 bits) specified by the A4 bit. Erased memory block consists of zeroes.

Setting bit 6 (EBW) to 1 will force the EEPROM memory block specified by the A4 bit to be programmed to the same 8-bit word found in the EEPROM data input register (39_{HEX}).

Note: after block operations the block erase (EBE) or write (EBW) control bit need to be written back to value 0 to return normal operation.

Table 5. MAS6502 EEPROM control register (3A_{HEX})

Bit Number	Bit Name	Description	Value	Function
7	EBE	EEPROM Block Erase	0	-
			1	Erase 128-bit block of EEPROM
6	EBW	EEPROM Block Write	0	-
			1	Write EEPROM data input register (39 _{HEX}) data into 128-bit block of EEPROM
5	EETEST	EEPROM Test Mode Enable	0	-
			1	Test mode enabled
4-3	VEE[1:0]	EEPROM test read mode selection	11	Internal high test read
			10	Internal low test read
			00	FORBIDDEN
			01	FORBIDDEN
2	CPTEST	Charge pump test input pin	0	Programming allowed
			1	Output protection of CP disabled
1	DMA	Direct Memory Access	TBD	TBD
0	PARITY	Parity Access	TBD	TBD

TBD = To be defined

The MAS6502 EEPROM status register (3C_{HEX}), bits (7:6), reflect the EEPROM operation status. See table 6. This register can be used to verify that the EEPROM operation has been accomplished without errors.

Table 6. MAS6502 EEPROM status register (3C_{HEX}). Only bits (7:6) are used.

Bit Number	Bit Name	Description	Value	Function
7	ERROR	EEPROM error detection	0	No errors
			1	1 (or more) data error(s)
6	DED	EEPROM double error detection	0	No errors
			1	2 (or more) data errors
5-0			X	-

X = Don't care

SERIAL DATA INTERFACE (I²C[®] BUS) CONTROL

Serial Interface

MAS6502 has an I²C[®] bus compatible two wire serial data interface comprising of serial clock (SCL) and bi-directional serial data (SDA) pins. Both the SCL & SDA lines, in the I²C[®] bus, are of open-drain design, thus, external pull-up resistors are needed.

The serial data interface is used to configure and start the A/D conversion and read the measurement result when the A/D conversion has been finished.

The digital interface includes also end of conversion (EOC) and master reset (XCLR) pins. The EOC goes high when the A/D conversion has finished.

The XCLR signal is active low and used to reset the A/D converter. A reset initializes the serial **Device Address**

The I²C[®] bus definition allows several I²C[®] bus devices to be connected to the same bus. The devices are distinguished from each other by unique device address codes. MAS6502 device address is

Table 7. MAS6502 device address

A7	A6	A5	A4	A3	A2	A1	W/R
1	1	1	0	1	1	1	0/1

I²C[®] Bus Protocol Definitions

Data transfer is initiated with a Start bit (S) when SDA is pulled low while SCL stays high. Then, SDA sets the transferred bit while SCL is low and the data is sampled (received) when SCL rises. When the transfer is complete, a Stop bit (P) is sent by releasing the data line to allow it to be pulled up while SCL is constantly high.

Figure 3 shows the start (S) and stop (P) bits and a

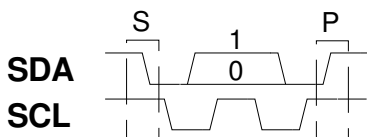

Figure 3. I²C[®] bus protocol definitions

Bus communication includes Acknowledge (A) and not Acknowledge (N) messages. To send an acknowledge the receiver device pulls the SDA low for one SCL clock cycle. For not acknowledge (N)

Abbreviations:

A= Acknowledge by Receiver
N = Not Acknowledge by Receiver
S = Start
Sr = Repeated Start

communication bus and sets internal registers and counters to value 00_{HEX}. After connecting the supply voltage to MAS6502, and before starting operating the device via the serial bus, it is required to reset the device with the XCLR reset pin or using reset register (30_{HEX}) if the supply voltage rise time has been longer than 400 ns. If the supply voltage rise time is shorter than this making an external reset is not necessary since the device is automatically reset by the power on reset (POR) circuitry. It is however recommended to use the XCLR reset feature to solve unexpected error state conditions. The XCLR pin can be left unconnected when not used. It has internal pull up to VDD. See Electrical Characteristics for the XCLR Pin Pull Up Current.



shown in table 7. The LSB bit of the device address defines whether the bus is configured for Read (1) or Write (0) operation.

data bit. Data must be held stable at the SDA pin when SCL is high. Data at the SDA pin can change value only when SCL is low.

Each SDA line byte must contain 8-bits when the most significant bit (MSB) is always first. Each byte has to be followed by an acknowledge bit (see further below). The number of bytes transmitted per transfer is unrestricted.

the receiver device leaves the SDA high for one SCL clock cycle in which case the master can then generate either a Stop (P) bit to abort the transfer, or a repeated Start (Sr) bit to start a new transfer.

P = Stop

 = from Master (MCU) to Slave (MAS6502)
 = from Slave (MAS6502) to Master (MCU)

SERIAL DATA INTERFACE (I²C[®] BUS) CONTROL

Conversion Starting – Write Sequence

Conversion is started by writing configuration bits into the ADC control register. The write sequence is illustrated in Table 8.

Table 8. MAS6502 I²C[®] bus write sequence

S	AW	A	AC	A	DC	A	P
---	----	---	----	---	----	---	---

Abbreviations:

AW = Device Write Address (%1110 1110)

AR = Device Read Address (%1110 1111)

AC = ADC Control Register Address (%1111 1111)

Ax = MSB (x=M, %1111 1101) or LSB (x=L, %1111 1110) ADC Result Register Address

DC = ADC Control Register Data

Dx = MSB (x=M) or LSB (x=L) ADC Result Register Data

Each serial bus operation, like write, starts with the start (S) bit (see figure 3). After start (S) the MAS6502 device address with write bit (AW, see table 7) is sent followed by an Acknowledge (A). After this the ADC control register address (see

table 1) is sent and followed by an Acknowledge (A). Next the ADC control register data (DC, see table 2) is written and followed by an Acknowledge (A). Finally the serial bus operation is ended with a stop (P) command (see figure 3).

A/D Conversion

After power-on-reset or external reset (XCLR) the EOC output is high. After an A/D conversion is started the EOC output is set low until the conversion is finished and the EOC goes back high, indicating that the conversion is done and data is ready for reading. The EOC is set low only by starting a new conversion. To save power the internal oscillator runs only during conversion.

During the A/D conversion period the input signal is sampled continuously leading to an output conversion result that is a weighted average of the samples taken. **Note:** The device should not be addressed via serial bus before the conversion has ended. Reading or writing to the device during the conversion may corrupt the conversion result.

Conversion Result – Read Sequence

Table 9 shows a general control sequence for a single register data read.

Table 9. MAS6502 I²C[®] bus single register (address Ax) read sequence

S	AW	A	Ax	A	Sr	AR	A	Dx	N	P
---	----	---	----	---	----	----	---	----	---	---

Table 10 shows the control sequence for reading the 16-bit A/D conversion result from both the MSB and LSB data registers. The LSB register data (DL) can be read right after the MSB register data (DM) in case the read sequence is continued (not ended

by a Stop bit P) since the register address is automatically incremented to point to the next register address (in this case to point to the LSB data register).

Table 10. MAS6502 I²C[®] bus MSB (first) and LSB (second) A/D conversion result read sequence

S	AW	A	AM	A	Sr	AR	A	DM	A	DL	N	P
---	----	---	----	---	----	----	---	----	---	----	---	---

APPLICATION INFORMATION

Figure 4. Typical application circuit

Together with a resistive pressure sensor, MAS6502 can be used in pressure measurement applications. An external micro-controller can control the MAS6502 via an I²C[®] serial interface. Note that the I²C[®] serial interface requires suitable pull up resistors connected to the SDA and SCL pins (see figure 4). Note that if there is only a single master device in the serial bus the master's SCL output can be push-pull output stage making the SCL pull-up resistor unnecessary.

The sensor is connected between the power supply voltage (VDD) and MAS6502 signal ground (COMMON) which can be internally connected to ground (GND). The sensor output is read as a differential signal through PI (positive input) and NI (negative input) to the $\Delta\Sigma$ converter in MAS6502.

Accuracy Improvement – Averaging

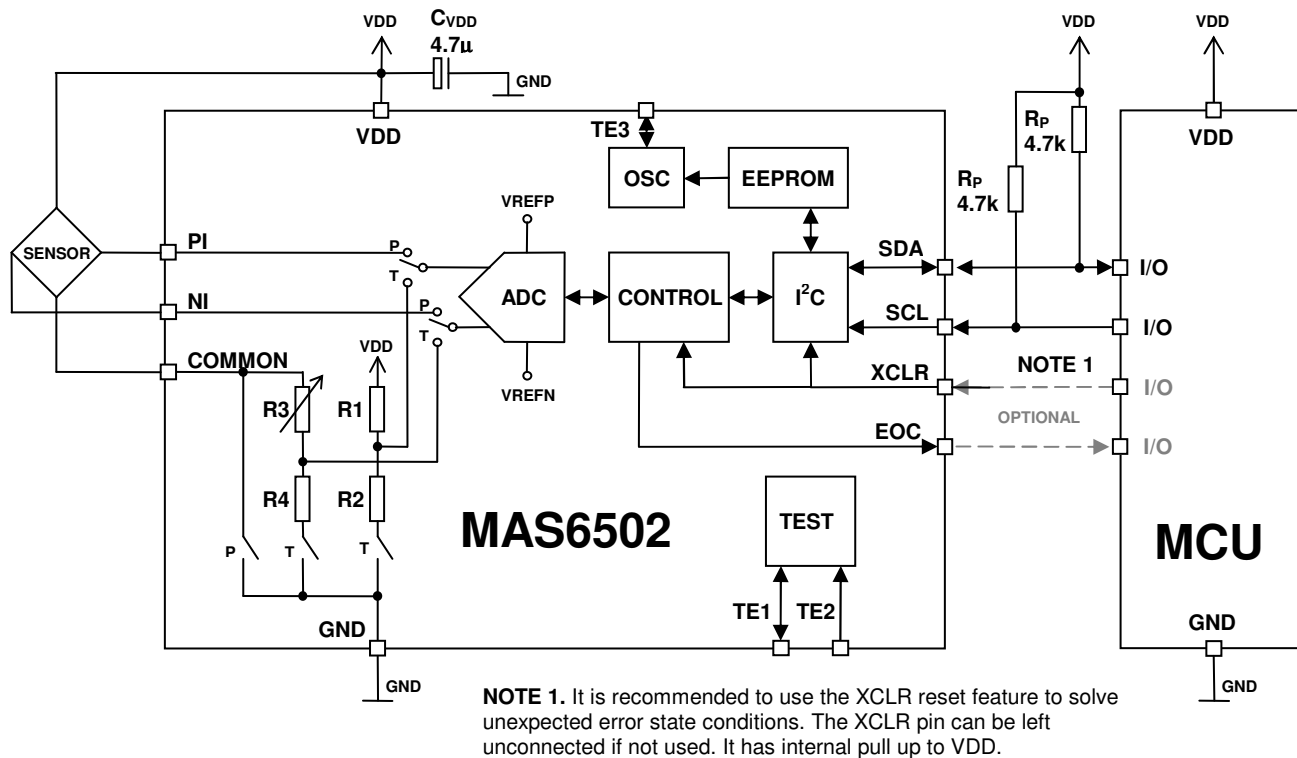
An averaging technique can be used to remove conversion error caused by noise and thus improve measurement accuracy. By doing several A/D conversions and calculating the average result it's possible to average out noise. Theoretically random

In the pressure measurement mode, the switches marked "P" are closed and the sensor output is fed through to the ADC. In the temperature measurement mode, the switches marked "T" are closed and the voltage at the ADC input is determined by the internal resistor array and the temperature-dependent resistance of the sensor. In this configuration the sensor bridge is connected as part of a Wheatstone resistor bridge circuit where the other four resistors (R1, R2, R3, R4) are inside the IC.

To guarantee conversion accuracy a supply voltage decoupling capacitor of 4.7 μ F or more should be placed between VDD and GND of MAS6502 (see C_{VDD} in figure 4).

noise is reduced by a factor \sqrt{N} where N is the number of averaged samples. A/D converter nonlinearities cannot be removed by averaging.

APPLICATION INFORMATION

Input Signal Range Definitions

The input signal voltage polarity is from positive input PI to the negative input NI. MAS6502 has input signal range (ISR) and offset (OFFSET) selection options that determines the input signal range of the A/D converter. The minimum and maximum input signal values in the linear input signal range (ISRLIN) are calculated as follows.

$$V_{IN_MIN} = OFFSET - \frac{ISRLIN}{2} \quad \text{Equation 1.}$$

$$V_{IN_MAX} = OFFSET + \frac{ISRLIN}{2} \quad \text{Equation 2.}$$

Table 11 shows minimum and maximum input signal values in the linear input signal range at different input signal range and offset selection combinations.

Table 11. Minimum and maximum input signal values in the linear input signal range

OFFSET [mV]	ISR [mV]	ISRLIN [mV]	VIN_MIN [mV]	VIN_MAX [mV]
0	325	260	-130	130
33	325	260	-97	163
0	220	176	-88	88
33	220	176	-55	121
0	150	120	-60	60
33	150	120	-27	93
0	100	80	-40	40
33	100	80	-7	73

The digital A/D conversion result, CODE, depends on the input signal as follows.

$$CODE = CODE_{MAX} \cdot \left[0.5 + \frac{V_{IN} - OFFSET}{ISR} \right] \quad \text{Equation 3.}$$

CODE = digital A/D-conversion output code

CODE_{MAX} = A/D-converter maximum code (minimum code is zero)

See page 4 Electrical Characteristics for CODE_{MAX} values at different over sampling ratio (OSR) selections.

Pressure Measurement Configuration

Piezoresistive absolute pressure sensor can be modeled roughly with following signal voltage characteristic when including only first order pressure and temperature characteristics..

$$V_{IN}(p, T) = \frac{VDD}{VDD_{REF}} \cdot \left[\frac{FS \cdot (1 + TC_{FS} \cdot (T - T_{REF}))}{P_{FS}} \cdot p + OS \cdot (1 + TC_{OS} \cdot (T - T_{REF})) \right] \quad \text{Equation 4.}$$

VDD = supply voltage

VDD_{REF} = reference supply voltage at which the sensor parameters (FS, OS) have been specified (often 5V)

p = pressure [bar]

p_{FS} = full-scale pressure range [bar]

FS = full-scale span [V]

OS = zero pressure offset [V]

TC_{FS} = full-scale span temperature coefficient [ppm/°C]

TC_{OS} = offset temperature coefficient [ppm/°C]

T_{REF} = reference temperature for resistor values [°C]

T = actual temperature to be measured [°C]

The above linear approximation includes sensor full-scale span and offset signal temperature dependencies.

APPLICATION INFORMATION

Temperature Measurement Configuration

In the temperature measurement configuration the piezoresistive sensor R_S is connected into a Wheatstone resistor bridge configuration together with four internal resistors R_1 , R_2 , R_3 and R_4 . See figure 5.

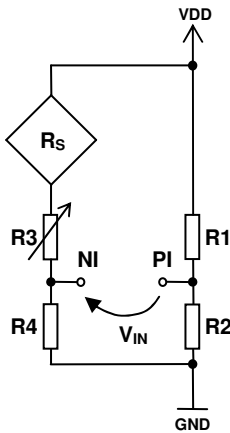

Figure 5. Temperature Measurement Configuration

In the temperature measurement configuration the A/D converter input signal has the following characteristics.

$$V_{IN}(T) = VDD \cdot \left[\frac{1}{\frac{R_1}{R_2} + 1} - \frac{1}{\frac{R_S \cdot [1 + TC_S \cdot (T - T_{REF})]}{R_4 \cdot [1 + TC_R \cdot (T - T_{REF})]} + \frac{R_3}{R_4} + 1}} \right] \quad \text{Equation 5.}$$

VDD = supply voltage

R_S = sensor bridge resistance [Ω]

$R_{1,2,3,4}$ = internal resistors [Ω]

TC_S = sensor resistance temperature coefficient [ppm/ $^{\circ}\text{C}$]

TC_R = internal resistor temperature coefficient [ppm/ $^{\circ}\text{C}$]

T_{REF} = reference temperature for resistor values [$^{\circ}\text{C}$]

T = actual temperature to be measured [$^{\circ}\text{C}$]

From equation 5 we get that the temperature signal has a rising temperature dependency vs. temperature when the sensor resistance has a positive temperature coefficient $TC_S > 0$. With negative sensor resistance temperature coefficient $TC_S < 0$ the signal has a falling temperature dependency vs. temperature. See the signal illustration in figure 6.

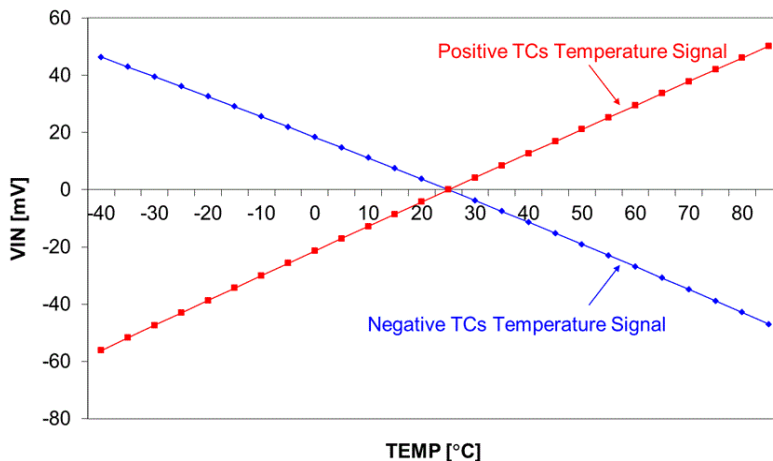
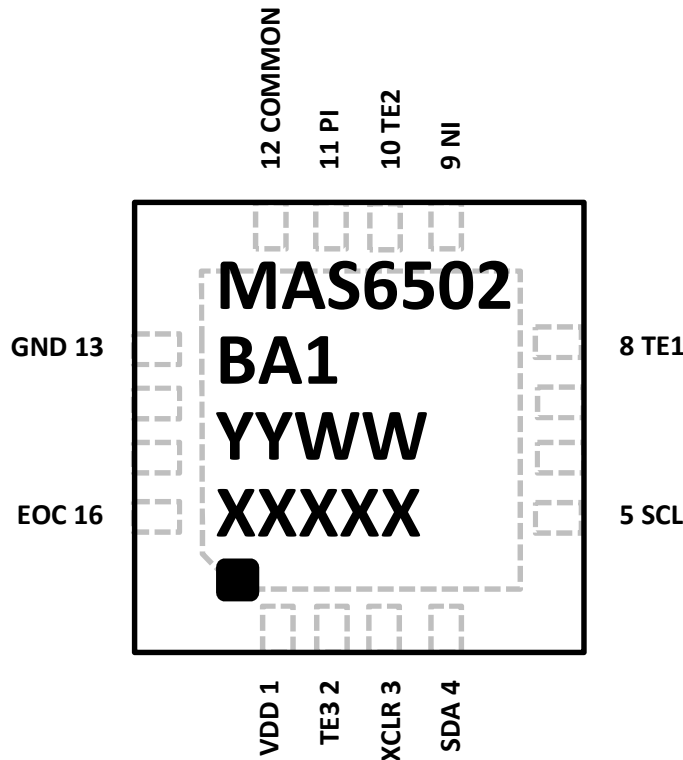

Figure 5. Temperature signal dependency of sensor resistance temperature coefficient

MAS6502BA1 IN QFN-16 4x4x0.75 PACKAGE



Top Marking Information:
 MAS6502 = Product Number,
 BA1 = Version Number
 YYWW = Year Week
 XXXXX = Lot Number

QFN-16 4x4x0.75 PIN DESCRIPTION

Pin Name	Pin	Type	Function	Notes
VDD	1	P	Power Supply Voltage	
TE3	2	DI/O	Test Pin 3 for internal clock oscillator	1
XCLR	3	DI	Reset I2C, Stop Conversion	2
SDA	4	DI/O	Serial Bus Data Input/Output	
SCL	5	DI	Serial Bus Clock	
	6	NC		
	7	NC		
TE1	8	DI/O	Test Pin 1	1
NI	9	AI	ADC Negative Input	
TE2	10	DI	Test Pin 2	1
PI	11	AI	ADC Positive Input	
COMMON	12	AI	Sensor Ground	
GND	13	G	Power Supply Ground	
	14	NC		
	15	NC		
EOC	16	DO	End of Conversion	

NC = Not Connected, P = Power, G = Ground, DO = Digital Output, DI = Digital Input, AO = Analog Output

Note 1: Test pins TE1, TE2 and TE3 must be left floating.

Note 2: XCLR pin can be left unconnected when not used. It has internal pull up to VDD.

PACKAGE (QFN-16 4X4x0.75) OUTLINE

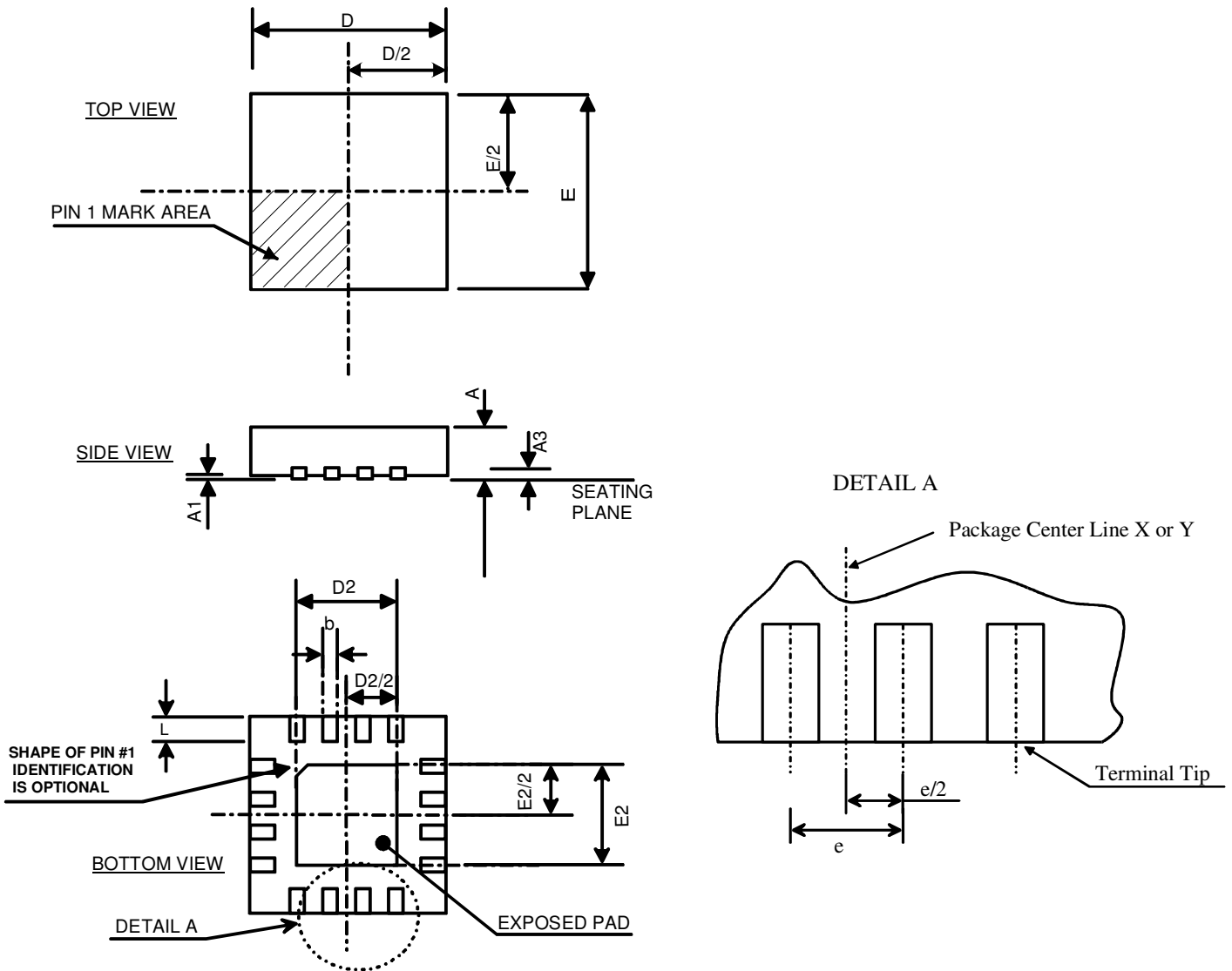

Symbol	Min	Nom	Max	Unit
PACKAGE DIMENSIONS				
A	0.700	0.750	0.800	mm
A1	0.000	0.020	0.050	mm
A3		0.203 REF		mm
b	0.250	---	0.350	mm
D	3.950	4.000	4.050	mm
D2 (Exposed.pad)	2.700	---	2.900	mm
E	3.950	4.000	4.050	mm
E2 (Exposed.pad)	2.700	---	2.900	mm
e		0.650 BSC		mm
L	0.350	---	0.450	mm

Dimensions do not include mold or interlead flash, protrusions or gate burrs.

SOLDERING INFORMATION

◆ For Lead-Free / Green QFN 4mm x 4mm

Resistance to Soldering Heat	According to RSH test IEC 68-2-58/20
Maximum Temperature	260°C
Maximum Number of Reflow Cycles	3
Reflow profile	Thermal profile parameters stated in IPC/JEDEC J-STD-020 should not be exceeded. http://www.jedec.org
Lead Finish	Solder plate 7.62 - 25.4 μm, material Matte Tin

EMBOSSED TAPE SPECIFICATIONS

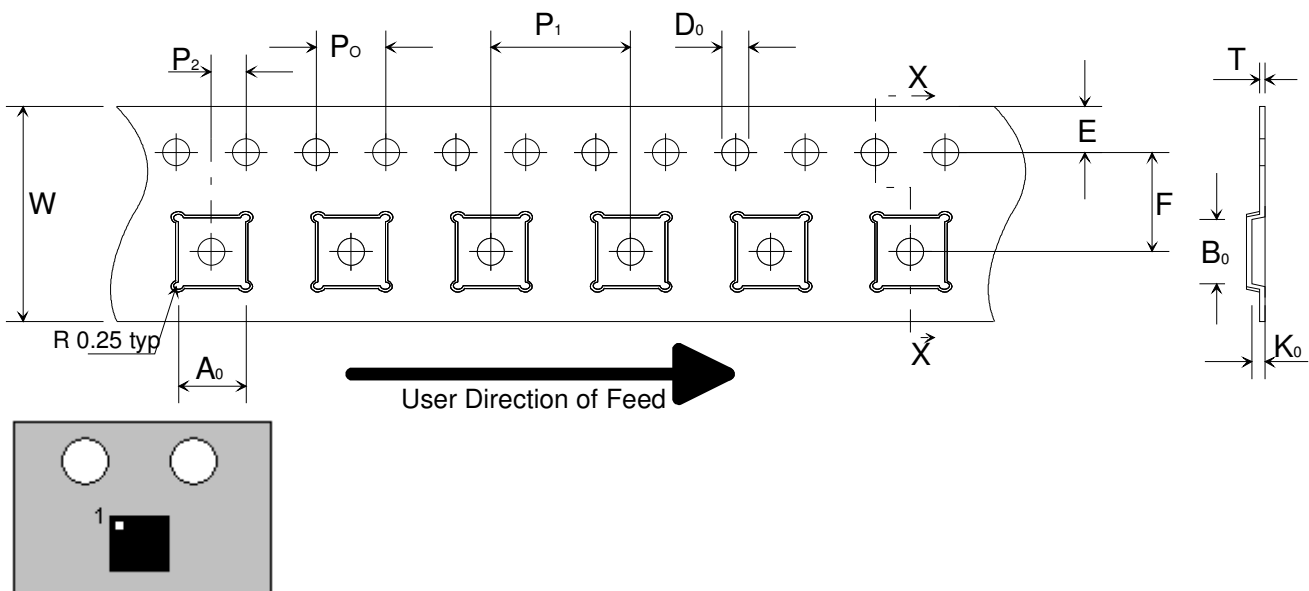

Orientation on tape

Dimension	Min/Max	Unit
A ₀	4.30 ±0.10	mm
B ₀	4.30 ±0.10	mm
D ₀	1.50 +0.1/-0.0	mm
E	1.75	mm
F	5.50 ±0.05	mm
K ₀	1.10 ±0.10	mm
P ₀	4.0	mm
P ₁	8.0 ±0.10	mm
P ₂	2.0 ±0.05	mm
T	0.3 ±0.05	mm
W	12.00 ±0.3	mm

All dimensions in millimeters

REEL SPECIFICATIONS

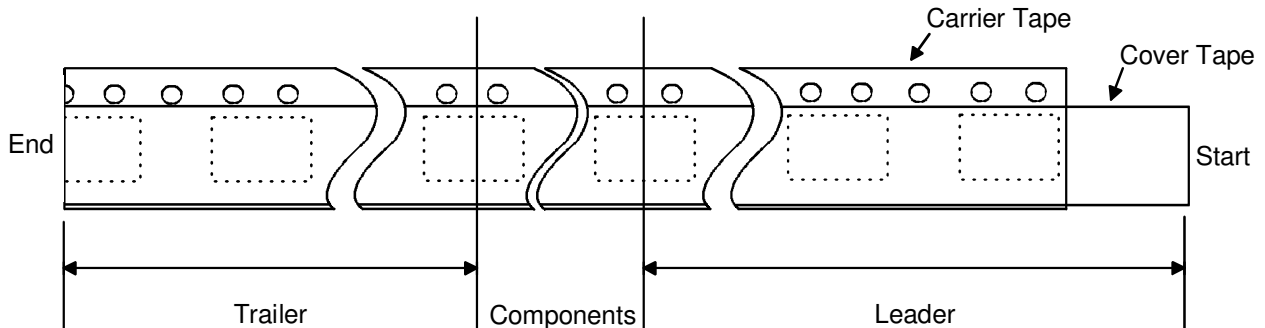
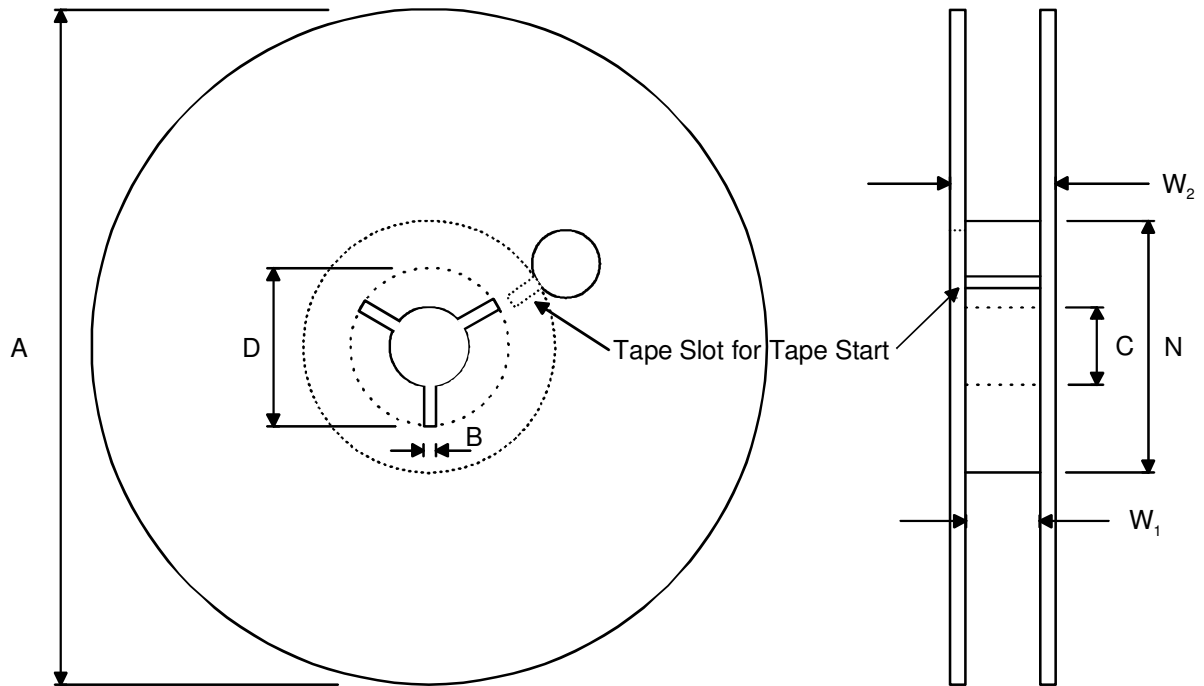

Dimension	Min	Max	Unit
A		330	mm
B	1.5		mm
C	12.80	13.50	mm
D	20.2		mm
N	100		mm
W ₁ (measured at hub)	12.4	14.4	mm
W ₂ (measured at hub)		18.4	mm
Trailer	160		mm
Leader	390, of which minimum 160 mm of empty carrier tape sealed with cover tape		mm

Reel Material: Conductive, Plastic Antistatic or Static Dissipative

Carrier Tape Material: Conductive

Cover Tape Material: Static Dissipative

ORDERING INFORMATION

Product Code	Product	Description
MAS6502BA1WA100	Piezoresistive Sensor Signal Interface IC	EWS-tested wafer, thickness 480 µm.
MAS6502BA1WA105	Piezoresistive Sensor Signal Interface IC	Dies on waffle pack, thickness 480 µm
MAS6502BA1Q1706	Piezoresistive Sensor Signal Interface IC	QFN-16 4x4x0.75, Pb-free, RoHS compliant, Tape & Reel, 1000/3000 pcs components on reel

Contact Micro Analog Systems Oy for other wafer thickness options.

LOCAL DISTRIBUTOR

MICRO ANALOG SYSTEMS OY CONTACTS

Micro Analog Systems Oy Kutomotie 16 FI-00380 Helsinki, FINLAND	Tel. +358 10 835 1100 Fax +358 10 835 1109 http://www.mas-oy.com
---	--

NOTICE

Micro Analog Systems Oy (MAS) reserves the right to make changes to the products contained in this data sheet in order to improve the design or performance and to supply the best possible products. MAS assumes no responsibility for the use of any circuits shown in this data sheet, conveys no license under any patent or other rights unless otherwise specified in this data sheet, and makes no claim that the circuits are free from patent infringement. Applications for any devices shown in this data sheet are for illustration only and MAS makes no claim or warranty that such applications will be suitable for the use specified without further testing or modification.

MAS products are not authorized for use in safety-critical applications (such as life support) where a failure of the MAS product would reasonably be expected to cause severe personal injury or death. Buyers represent that they have all necessary expertise in the safety and regulatory ramifications of their applications, and acknowledge and agree that they are solely responsible for all legal, regulatory and safety-related requirements concerning their products and any use of MAS products in such safety-critical applications, notwithstanding any applications-related information or support that may be provided by MAS. Further, Buyers must fully indemnify MAS and its representatives against any damages arising out of the use of MAS products in such safety-critical applications.

MAS products are neither designed nor intended for use in military/aerospace applications or environments. Buyers acknowledge and agree that any such use of MAS products which MAS has not designated as military-grade is solely at the Buyer's risk, and that they are solely responsible for compliance with all legal and regulatory requirements in connection with such use.

MAS products are neither designed nor intended for use in automotive applications or environments. Buyers acknowledge and agree that, if they use any non-designated products in automotive applications, MAS will not be responsible for any failure to meet such requirements.