

# EXTREME ENVIRONMENT

## SMD HIGH-TEMPERATURE CRYSTAL OSCILLATORS

### FMOCHT7S SERIES

Extreme Temperature  
Crystal Oscillators

CERAMIC SMD 7x7

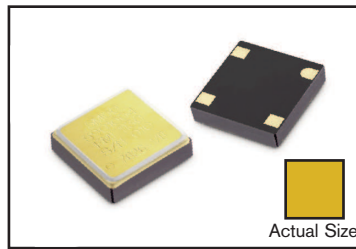

- 16 kHz to 80 MHz
- +1.8 Volts and Above
- High-Shock & Vibration
- -100°C to +210°C
- Extended Operating Life

### SPECIFICATIONS



Parameter	Specification
Frequency Range	16.00 kHz to 80.00 MHz
Operating Temperature Range	-100°C to +210°C, Customer Specified
Overall Frequency Tolerance vs. Temperature	<i>typical:</i> ±100ppm, ±150ppm, ±175ppm, and ±250ppm <i>example:</i> ±200ppm; -40°C to +200°C <i>example:</i> ±250ppm; -40°C to +230°C <i>example:</i> ±60ppm; 0°C to +200°C
<i>Customer Specified &amp; Temperature Range Dependent- (please inquire, call the factory)</i>	
Storage Temperature	-100°C to +240°C
Supply Voltage	+1.8V, 2.5V, 3.3V, 5V (all ± 10%) Inquire about lower voltage options.
Supply Current	See table below (inquire on extreme low-power)
Rise and Fall Time (voltage, load & freq. dependent)	1~10 nsec
Start-up Time	10 ms max. < 5 ms typical
Output	CMOS, (SOI Option, please inquire)
Output Enable Options	Enabled on Logic "1" (available for temperatures up to +210°C)
Screening / Testing Available	per MIL-PRF-55310 or Custom

Established and Guaranteed Long-Term Operating Life at the Extreme High-Temperature

FMI continuously performs life test on high temperature products. Inquire about the life test relevant to your specific application.

#### CERAMIC SMD

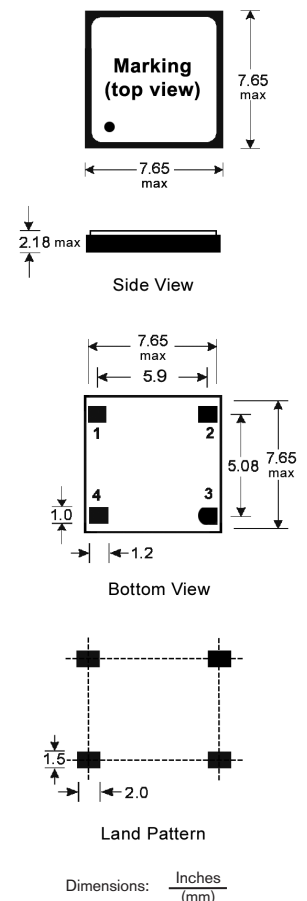

#### PACKAGE OPTIONS

- 4 Pad
  - 4 Pad with Gullwing Leads
- also available:  
J-Lead and Flat J-Lead; inquire

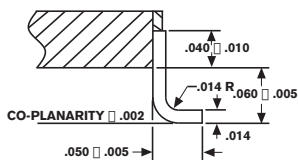

JEDEC TYPE MO-111  
"GULLWING" FORM

All specifications subject to change without notice.

#### SUPPLY CURRENT (mA)

Voltage	Frequency							
	16 kHz	*32.768 kHz	5 MHz		16 MHz		24 MHz	
	<i>std</i>	<i>std</i>	<i>std</i>	<i>low power</i>	<i>std</i>	<i>low power</i>	<i>std</i>	<i>low power</i>
+2.5V	0.125	0.25	0.8	0.25	2.5	0.6	4.5	0.8
+3.3V	0.23	0.45	1.2	0.45	4.0	0.8	6.0	1.1
+5.0V	0.6	1.1	2.6	0.75	8.0	1.4	11.0	1.9

\*Real Time Clock Stability: ±60ppm 0 to +200°C (0.8mA @ +2.5V) Available

Ultra-low-power, real-time-clocks, now available with even lower current than specified herein. Please Inquire

#### PIN FUNCTION TABLE

Pad	Function
1	NC or Tri-state
2	Ground (Case)
3	Output
4	Supply Voltage (Vcc)

PLEASE CONTACT US FOR PART NUMBERS, HOW TO ORDER,  
ADDITIONAL PRODUCT SPECIFICATIONS & OR YOUR CUSTOM REQUIREMENTS

Issue 1 | 02232012