

General Description

HTC2500 is a simple clock IC that was built using our micro RTOS.

Features:

- Operation from low cost low power 32768Hz crystal
- Supports backup power supply in case of main power failure
- Simple intuitive interface for adjusting clock
- Minimum external components

The schematics below show the typical connection diagram. HTC2500 uses four digits and a common cathode seven segment display.

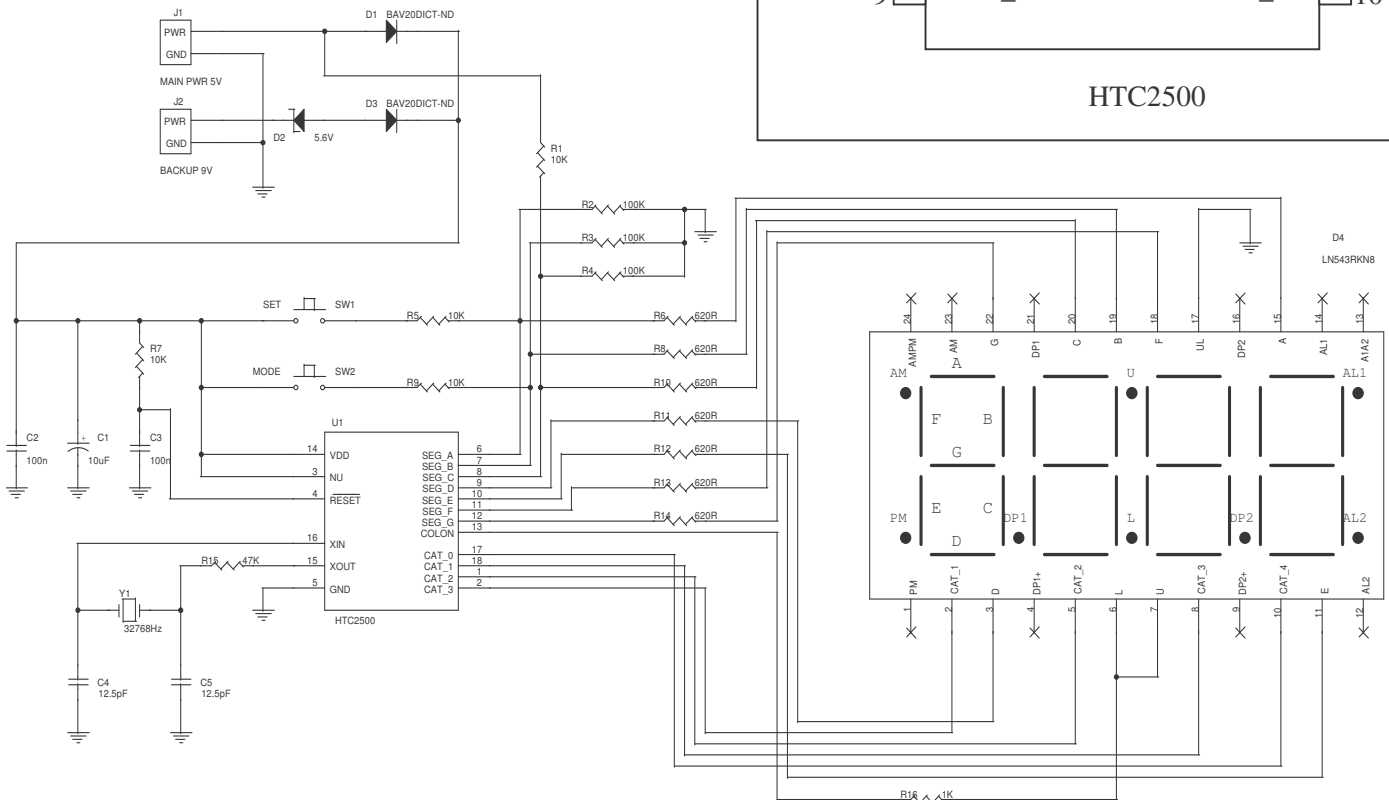
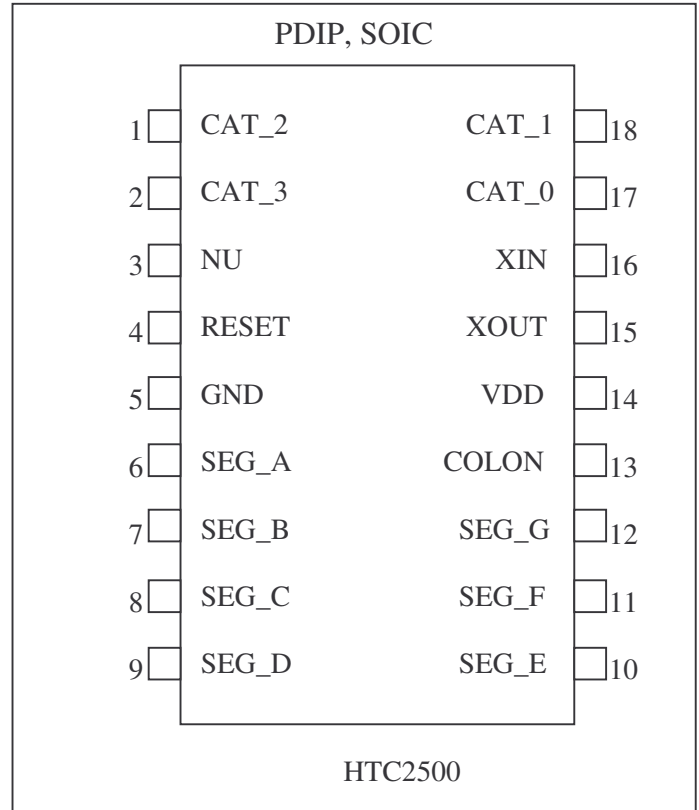

Crystal Selection

Please note that R15, C4 and C5 values shown in the schematics above are for reference only, consult the manufacturer of the Y1 crystal for recommended values. The precision of the clock depends on the crystal used and values selected for the above components. When choosing the crystal, make sure that it has ± 20 PPM tolerance in the temperature range used. For example, a crystal rated ± 20 PPM in the temperature range of -10 to $+60$ degrees Celsius is a good choice.

Switch Selection

The Set and Mode switch inputs are internally de-bounced, which eases switch selection. You can even use two wires laid out in parallel and conductivity of your skin would be enough to make it work as a switch. Also, conductive rubber can be used to design your own decorative switch.

Display Selection

Several factors should be considered in the seven-segment LED display selection.

1. Average Luminous Intensity (in μCd) at 3.5ma. This parameter determines the brightness of the display and varies widely even in one device family.
2. Forward voltage: HTC2500 can drive LED displays with a forward voltage rating of 1.6 to 4.2V (this range covers most of the LEDs and seven segment displays). This rating corresponds to the number of LED's used in each segment and the color of the LEDs. For example, a red LED has 2.0V forward voltage. This means we can use two red LEDs in series for each segment if we are building our own custom display.

Main and Backup Power Selection

The voltage on the VDD pin should be in a range from $+3.0$ to $+6.2\text{V}$. An example of good Backup power would be a Lithium battery (3V). In case of using a 9V battery for backup we should replace D1 in the schematics above with Zener connected backwards. We use Zener for voltage drop. Voltage rating for Zener in this case should be $9\text{V} - \text{MPV} - 0.5\text{V}$ volts minimum (MPV stands for the main power voltage and 0.5 is the D1 diode forward drop voltage). HTC2500 uses about 0.12mA current from 5V (depending on the crystal selection) in power down mode. If we are using a 9V alkaline battery with 500mA/H capacity for backup power it will keep HTC2500 alive for about 138 days. Please note that we don't guarantee this value because it depends on clock design specifications and component selection that are out of our control.

R5 and C3 Value Selection

Values of R5 and C3 are for reference only. They might need adjustment depending on crystal selection. The basic rule of thumb is that the Reset line should be held below $0.85 \cdot \text{VDD}$ until the clock generator is started (depending on the crystal used). The R5 value should be in the range of 0 to 720K.

Modes of Operation

Mode	Display characters	Notes	Key Behavior
Start up	HI	Says Hi for one second, we are still investigating if it means High Tech Chips or just Hi.	Ignored
Normal	HH : MM	Leading zero in HH is not displayed.	Set: Ignored Mode: Go to Set Hour mode
Set Hour	HH : - -	- - characters indicate that clock is in one of setting modes.	Set: increment HH Mode: Go to Set Minute mode
Set Minute	- - : MM	Same as above	Set: increment MM Mode: Go to Set Second mode
Set Second	- - : SS	Same as above	Set: zero SS. Mode: Go to Normal mode
Power Saving	None!	Requires backup battery	None! Wakes up in Normal mode once main power is restored

Abbreviations used:

- HI Still under investigation, we would like to hear from you on this subject. Please use Feedback form on our web site (www.hightechips.com) to replay.
- MM Minutes
- HH Hours, please note that our clock uses a 12-hour format, leading zeroes are not displayed in HH.
- SS Seconds
- G elements of the seven segment display

Set and Mode Key Behavior

In all modes of operation, the display is changed when the key is released. If you hold any key for more then 2 seconds, the display will change faster, this functionality is useful when setting minutes and hours.

Signal Description

Abbreviations used: O - output, I - input, P - power

Name	Pin	I / O	Description	Name	Pin	I / O	Description
CAT_2	1	O	Cathode 2 ^{NOTE 1}	SEG_E	10	O	Display Segment E ^{NOTE 2}
CAT_3	2	O	Cathode 3 ^{NOTE 1}	SEG_F	11	O	Display Segment F ^{NOTE 2}
NU	3	I	Not used. Connect to VCC.	SEG_G	12	O	Display Segment G ^{NOTE 2}
#RESET	4	I	Reset ^{NOTE 4}	COLON	13	O	Colon output ^{NOTE 2}
GND	5	P	Power ground	VDD	14	P	Power ^{NOTE 5}
SEG_A/ SET	6	I/O	Display Segment A ^{NOTE 2}	XOUT	15	O	Clock generator output.
SEG_B/ MODE	7	I/O	Display Segment B ^{NOTE 2}	XIN	16	I	Clock generator input.
SEG_C/ PWR_OK	8	I/O	Display Segment C ^{NOTE 3}	CAT_1	17	O	Cathode 1 ^{NOTE 1}
SEG_D	9	O	Display Segment D ^{NOTE 2}	CAT_0	18	O	Cathode 0 ^{NOTE 1}

Note 1:

These outputs can sink up to 25mA of current. Voltage on this pin at 25mA is 1V.

Note 2:

This output can source up to 20mA. Limiting resistors should be used with these outputs. When number eight is displayed, maximum power is consumed. CAT_N sink current should be limited to a maximum of 25mA. So each output should source no more than $25\text{mA}/7=3.6\text{mA}$. In order to find the appropriate values for these resistors, we subtract the Forward Voltage rating value of our display from VCC and divide that by 3.6mA. The Forward Voltage value depends on the display used. Please consult the manufacturer's data sheet for the chosen display.

Note 3:

This output can source up to 20mA. A limiting resistor should be used with this output. This output should not source more than 5mA. The PWR_OK (Power OK) pin should be connected to the main power via resistor. The value of the resistor should be 1K to 100K. If this pin is connected to VCC without a power limiting resistor, excessive damage to the part will result.

Note 4:

The values of R5 and C3 are for reference only. These may need adjustment depending on crystal selection. The basic rule of thumb is that the Reset line should be held below $0.85 \cdot VDD$ until clock the generator is started (depending on the crystal used). The R5 value could be in the range of 0 to 720K.



Note 5:
Voltage on this pin should be in range of +3.0V to +6.2V.

Ordering Information

When ordering, please use the part numbering scheme below.

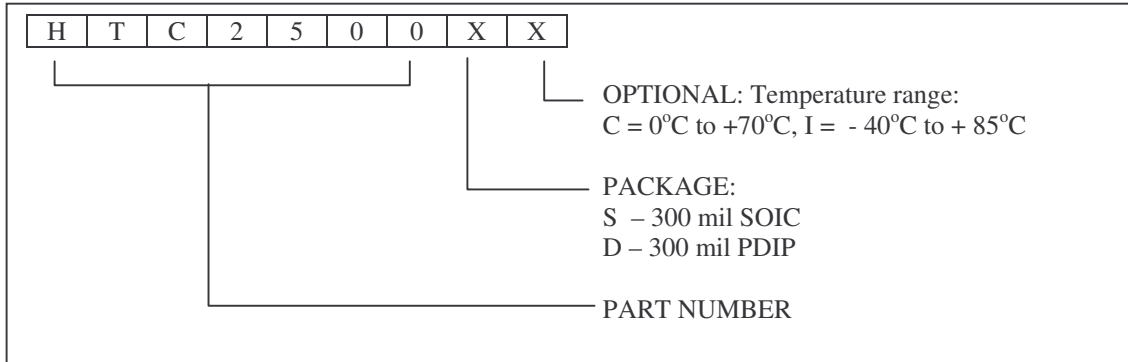

Mechanical Information

18-Lead Plastic Dual In-line (P) – 300 mil (PDIP)

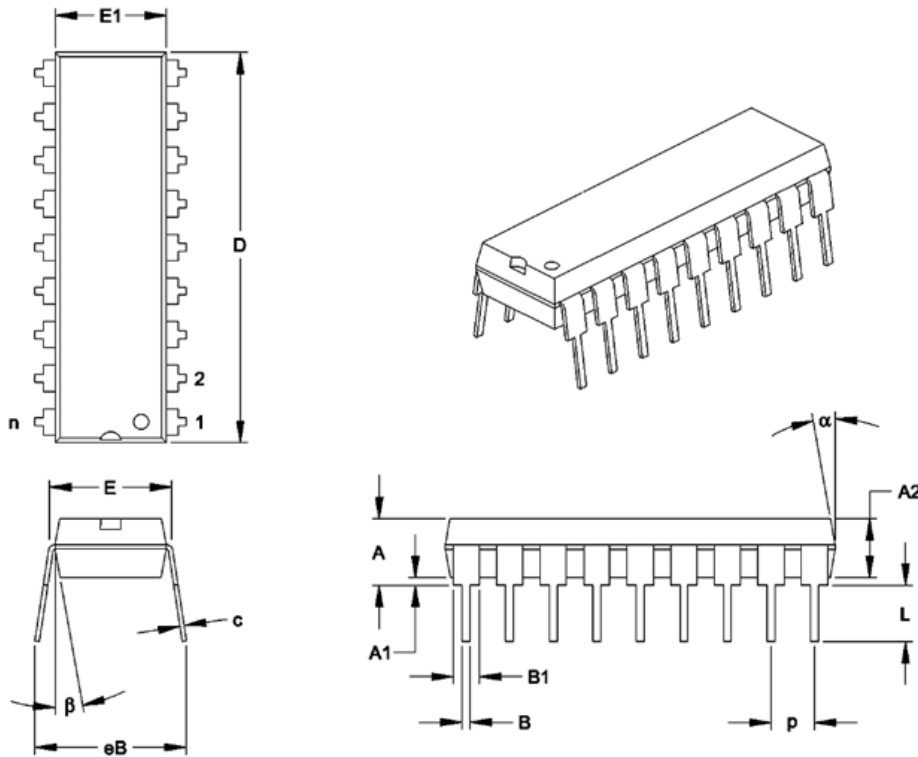

Units		INCHES*			MILLIMETERS		
		MIN	NOM	MAX	MIN	NOM	MAX
Dimension Limits							
Number of Pins	n		18			18	
Pitch	p		.100			2.54	
Top to Seating Plane	A	.140	.155	.170	3.56	3.94	4.32
Molded Package Thickness	A2	.115	.130	.145	2.92	3.30	3.68
Base to Seating Plane	A1	.015			0.38		
Shoulder to Shoulder Width	E	.300	.313	.325	7.62	7.94	8.26
Molded Package Width	E1	.240	.250	.260	6.10	6.35	6.60
Overall Length	D	.890	.898	.905	22.61	22.80	22.99
Tip to Seating Plane	L	.125	.130	.135	3.18	3.30	3.43
Lead Thickness	c	.008	.012	.015	0.20	0.29	0.38
Upper Lead Width	B1	.045	.058	.070	1.14	1.46	1.78
Lower Lead Width	B	.014	.018	.022	0.36	0.46	0.56
Overall Row Spacing	eB	.310	.370	.430	7.87	9.40	10.92
Mold Draft Angle Top	α	5	10	15	5	10	15
Mold Draft Angle Bottom	β	5	10	15	5	10	15

*Controlling Parameter

Notes:

Dimensions D and E1 do not include mold flash protrusions. Mold flash or protrusions shall not exceed .010" (0.254mm) per side.

JEDEC Equivalent: MS-001

18-Lead Plastic Small Outline (SO) – Wide, 300 mil (SOIC)

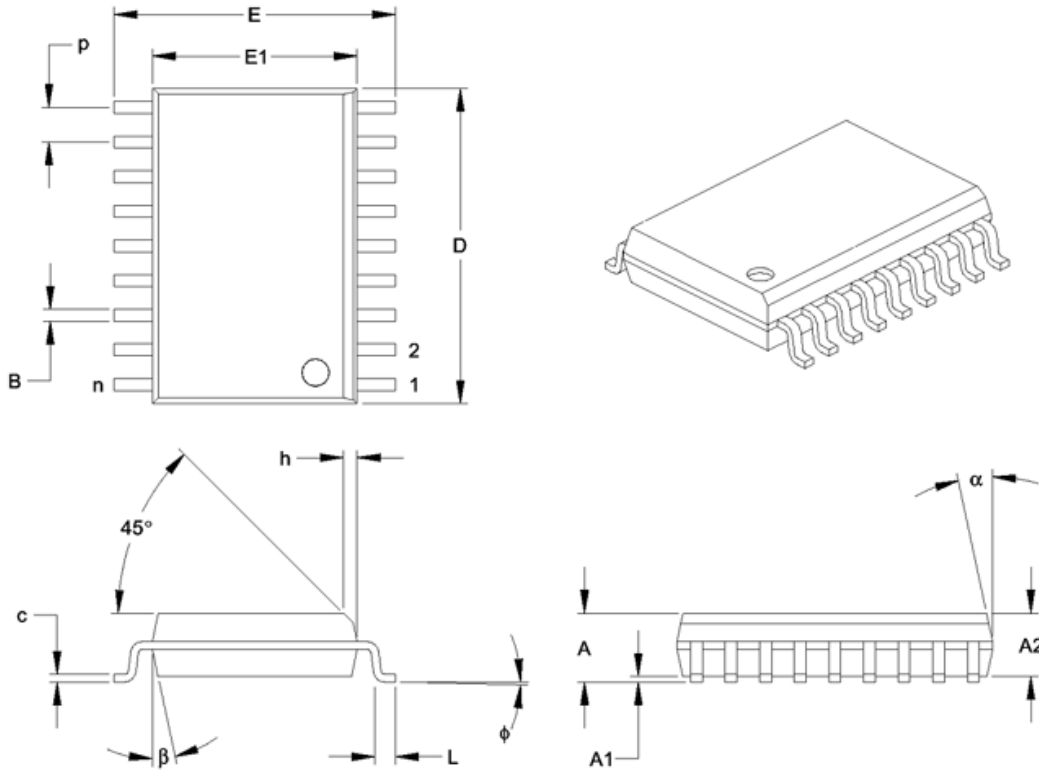

Units		INCHES*			MILLIMETERS		
		MIN	NOM	MAX	MIN	NOM	MAX
Number of Pins	n		18			18	
Pitch	P		.050			1.27	
Overall Height	A	.093	.099	.104	2.36	2.50	2.64
Molded Package Thickness	A2	.088	.091	.094	2.24	2.31	2.39
Standoff	A1	.004	.008	.012	0.10	0.20	0.30
Overall Width	E	.394	.407	.420	10.01	10.34	10.67
Molded Package Width	E1	.291	.295	.299	7.39	7.49	7.59
Overall Length	D	.446	.454	.462	11.33	11.53	11.73
Chamfer Distance	h	.010	.020	.029	0.25	0.50	0.74
Foot Length	L	.016	.033	.050	0.41	0.84	1.27
Foot Angle	ϕ	0	4	8	0	4	8
Lead Thickness	c	.009	.011	.012	0.23	0.27	0.30
Lead Width	B	.014	.017	.020	0.36	0.42	0.51
Mold Draft Angle Top	α	0	12	15	0	12	15
Mold Draft Angle Bottom	β	0	12	15	0	12	15

*Controlling Parameter

Notes:

Dimensions D and E1 do not include mold flash protrusions. Mold flash or protrusions shall not exceed .010" (0.254mm) per side.

JEDEC Equivalent: MS-013



HTC makes no warranty, express, statutory implied or by description, regarding the information set forth herein or regarding the freedom of the described devices from patent infringement. HTC makes no warranty, merchantability or fitness for any purposes. HTC reserves the right to discontinue production and change specifications and prices at any time and without notice. HTC's products are intended for use in commercial applications. Applications requiring extended temperature range, unusual environmental requirements, or high reliability applications such as military, medical, life-support or life-sustaining equipment, are not recommended without additional processing by HTC for such applications.

High Tech Chips, Inc.

www.hightechips.com

info@hightechips.com