

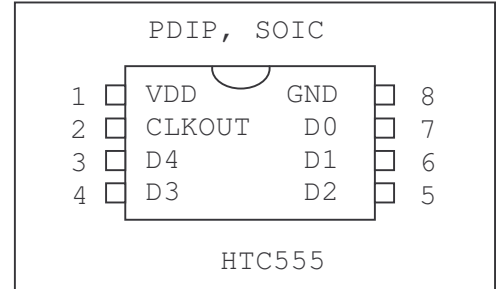

GENERAL PURPOSE CLOCK GENERATOR

1.0 General Description

HTC555 is a general-purpose clock generator. It requires no external components and provides a wide range of clock frequencies. It's very easy to use and provides a general clock solution to a wide range of applications. It is very simple to design and operate. Its output frequency is determined by the value of D[0:4] (Refer to the output frequency table).



Features

- Single chip solution
- Replaces clock generator
- Has 1% frequency accuracy at room temperature
- Has 10% frequency accuracy over the temperature range and VDD voltage range
- Requires no external components for operation

2.0 Application

Typical Connection Diagram

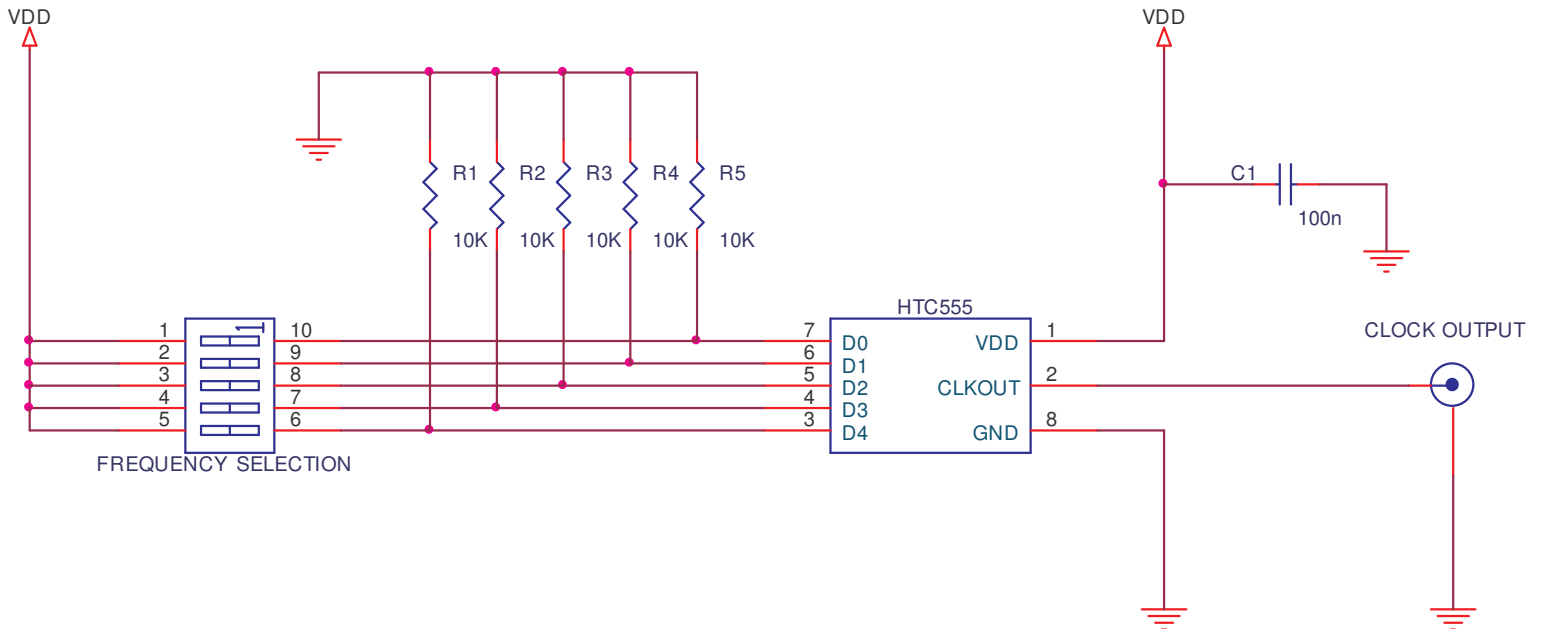



With this application we can generate 32 different output frequencies (See output frequency selection table for dip switch settings). Setting the “Frequency Selection” dip switch and powering sets the frequency. Please note that HTC555 reads this switch value only at power up. R1-R5 value can be in the range of 1K to 10K in this application. Please note that if only one frequency is needed then we can connect the D [0:4] pins directly to the ground or VDD. C1 is used as a de-coupling capacitor and can be omitted.

3.0 Pin out Description

Abbreviations used: O - output, I - input, P - power

Pin number	Name	I / O	Description	Notes
1	VDD	P	Power	+2.5V to + 5.5V
2	CLKOUT	O	Clock Output	Output frequency
3	D4	I	Frequency selector input.	Tie to GND or VDD
4	D3	I	Frequency selector input.	Tie to GND or VDD
5	D2	I	Frequency selector input.	Tie to GND or VDD
6	D1	I	Frequency selector input.	Tie to GND or VDD
7	D0	I	Frequency selector input.	Tie to GND or VDD
8	GND	P	Ground	Connect to ground

Output Frequency Selection

Abbreviations used: 0 – connection to GND, 1 – connection to VDD

D4	D3	D2	D1	D0	CLK (output frequency)
0	0	0	0	0	1Hz
0	0	0	0	1	10 Hz
0	0	0	1	0	20 Hz
0	0	0	1	1	30 Hz
0	0	1	0	0	40 Hz
0	0	1	0	1	50 Hz
0	0	1	1	0	60 Hz
0	0	1	1	1	70 Hz
0	1	0	0	0	80 Hz
0	1	0	0	1	90 Hz
0	1	0	1	0	100 Hz
0	1	0	1	1	200 Hz
0	1	1	0	0	300 Hz
0	1	1	0	1	400 Hz
0	1	1	1	0	500 Hz
0	1	1	1	1	600 Hz
1	0	0	0	0	700 Hz
1	0	0	0	1	800 Hz
1	0	0	1	0	900 Hz
1	0	0	1	1	1000 Hz



6.0 Mechanical Information

8-Lead Plastic Dual In-line (P) – 300 mil (PDIP)

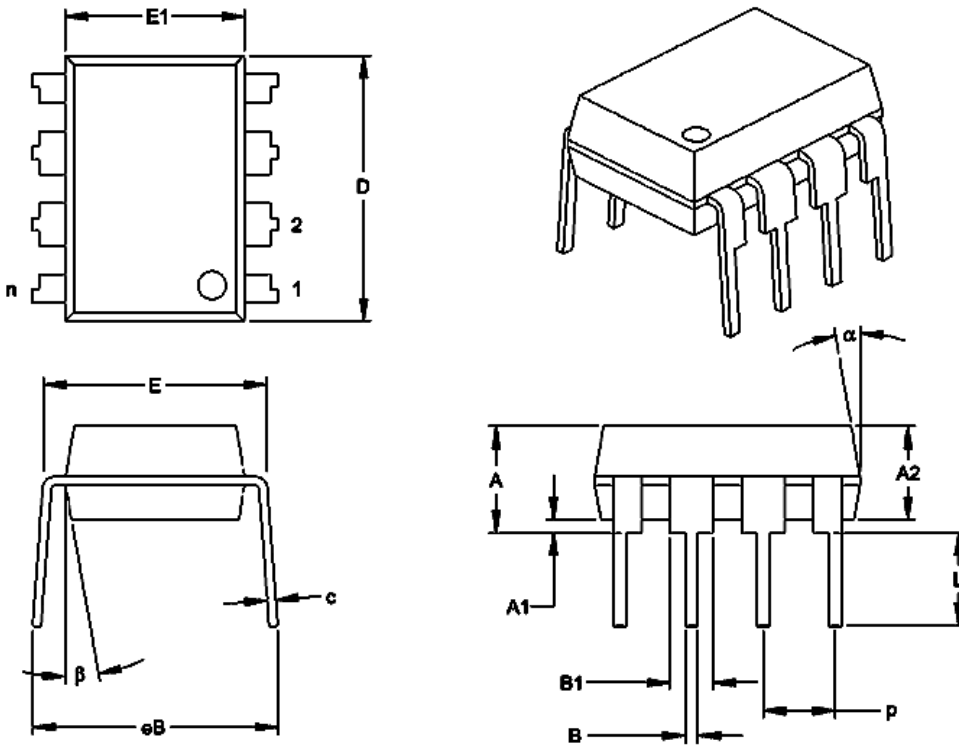

		INCHES*			MILLIMETERS		
Dimension Limits		MIN	NOM	MAX	MIN	NOM	MAX
Number of Pins	n		8			8	
Pitch	p		.100			2.54	
Top to Seating Plane	A	.140	.155	.170	3.56	3.94	4.32
Molded Package Thickness	A2	.115	.130	.145	2.92	3.30	3.68
Base to Seating Plane	A1	.015			0.38		
Shoulder to Shoulder Width	E	.300	.313	.325	7.62	7.94	8.26
Molded Package Width	E1	.240	.250	.260	6.10	6.35	6.60
Overall Length	D	.360	.373	.385	9.14	9.46	9.78
Tip to Seating Plane	L	.125	.130	.135	3.18	3.30	3.43
Lead Thickness	c	.008	.012	.015	0.20	0.29	0.38
Upper Lead Width	B1	.045	.058	.070	1.14	1.46	1.78
Lower Lead Width	B	.014	.018	.022	0.36	0.46	0.56
Overall Row Spacing	eB	.310	.370	.430	7.87	9.40	10.92
Mold Draft Angle Top	α	5	10	15	5	10	15
Mold Draft Angle Bottom	β	5	10	15	5	10	15

*Controlling Parameter

Notes:

Dimensions D and E1 do not include mold flash protrusions. Mold flash or protrusions shall not exceed .010" (0.254mm) per side.

JEDEC Equivalent:MS-001



8-Lead Plastic Small Outline (SM) – Medium, 208 mil (SOIC)

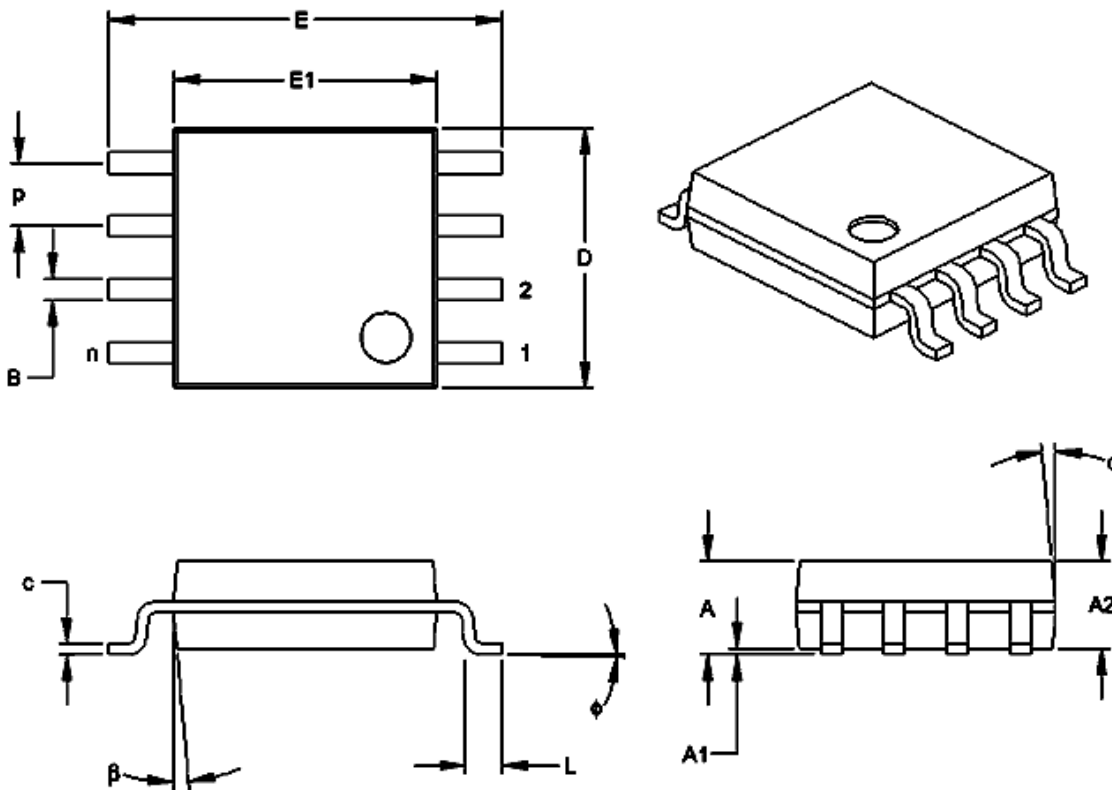

Units		INCHES*			MILLIMETERS		
Dimension Limits		MIN	NOM	MAX	MIN	NOM	MAX
Number of Pins	n		8			8	
Pitch	P		.050			1.27	
Overall Height	A	.070	.075	.080	1.78	1.97	2.03
Molded Package Thickness	A2	.069	.074	.078	1.75	1.88	1.98
Standoff	A1	.002	.005	.010	0.05	0.13	0.25
Overall Width	E	.300	.313	.325	7.62	7.95	8.26
Molded Package Width	E1	.201	.208	.212	5.11	5.28	5.38
Overall Length	D	.202	.205	.210	5.13	5.21	5.33
Foot Length	L	.020	.025	.030	0.51	0.64	0.76
Foot Angle	ϕ	0	4	8	0	4	8
Lead Thickness	c	.008	.009	.010	0.20	0.23	0.25
Lead Width	B	.014	.017	.020	0.36	0.43	0.51
Mold Draft Angle Top	α	0	12	15	0	12	15
Mold Draft Angle Bottom	β	0	12	15	0	12	15

*Controlling Parameter

Notes:

Dimensions D and E1 do not include mold flash protrusions. Mold flash or protrusions shell should not exceed .010" (0.254mm) per side.



HTC makes no warranty, express, statutory implied or by description, regarding the information set forth herein or regarding the freedom of the described devices from patent infringement. HTC makes no warranty, merchantability or fitness for any purposes. HTC reserves the right to discontinue production and change specifications and prices at any time and without notice. HTC's products are intended for use in commercial applications. Applications requiring extended temperature range, unusual environmental requirements, or high reliability applications such as military, medical, life-support or life-sustaining equipment, are not recommended without additional processing by HTC for such applications.

High Tech Chips, Inc.

www.hightechips.com

info@hightechips.com