

Flash

128 Mbit Serial Flash Memory
with Dual and Quad

■ FEATURES

- Single supply voltage 1.65~2V
- Fast Read for SPI mode
 - Support clock frequency up to 133MHz for all Read instructions.
 - Support Fast Read, 2READ, 4READ instructions.
 - Configurable dummy cycle number for fast read operation.
- Quad Peripheral Interface (QPI) available.
- Low power consumption
 - Active current: 35 mA (max.)
 - Standby current: 100 μ A (max.)
 - Deep Power Down current: 20 μ A (max.)
- Reliability
 - 100,000 typical program/erase cycles
 - 20 years Data Retention
- Program
 - Page programming time: 0.9 ms (typical)
- Page Programming
 - 256 byte per programmable page
- Program/Erase Suspend
- Erase
 - Chip Erase time 90 sec (typical)
- 64K bytes Block Erase time 0.4 sec (typical)
- 32K bytes Block Erase time 0.2 sec (typical)
- 4K bytes Sector Erase time 40 ms (typical)
- Status, Configuration and Security Register Feature
- Command Reset
- Advanced Security Features
 - Flexible Block Protection (BP0-BP3)
- Lockable 512 bytes OTP security sector
- SPI Serial Interface
 - SPI Compatible: Mode 0 and Mode 3
- End of program or erase detection
- 64-Bit Unique Serial Number for each device
- Support Serial Flash Discoverable Parameters (SFDP) mode
- Write Protect (\overline{WP})
- Reset Pin (\overline{RESET})
- All Pb-free products are RoHS-Compliant

■ ORDERING INFORMATION

Product ID	Speed	Package		Comments
F25D128QA –104PAIG	104MHz	8-lead SOIC	200 mil	Pb-free
F25D128QA –104VAIG	104MHz	8-lead VSOP	208 mil	Pb-free
F25D128QA –104HIG	104MHz	8-contact WSON	6x5 mm	Pb-free

■ GENERAL DESCRIPTION

The F25D128QA is a 128 Megabit, 1.8V only CMOS Serial Flash memory device. The device supports the standard Serial Peripheral Interface (SPI), a Dual/Quad SPI and QPI. ESMT's memory devices reliably store memory data even after 100,000 programming and erase cycles.

The memory array can be organized into 65,536 programmable pages of 256 byte each. 1 to 256 byte can be programmed at a time with the Page Program instruction.

The device features sector erase architecture. The memory array is divided into 4,096 uniform sectors with 4K byte each; 512 uniform blocks with 32K byte each; 256 uniform blocks with 64K

byte each. Sectors can be erased individually without affecting the data in other sectors. Blocks can be erased individually without affecting the data in other blocks. Whole chip erase capabilities provide the flexibility to revise the data in the device. The device has Sector, Block or Chip Erase but no page erase.

The sector protect/unprotect feature disables both program and erase operations in any combination of the sectors of the memory.

The device supports JEDEC standard manufacturer and device identification with a 64-bit Unique Serial Number.

Read Performance Comparison

Numbers of Dummy Cycles	Fast Read (MHz)	Dual Output Fast Read (MHz)	Quad Output Fast Read (MHz)	Dual IO Fast Read (MHz)	Quad IO Fast Read (MHz)
4	-	-	-	84*	70
6	104	104	84	104	84*
8	104*	104*	104*	104	104
10	133	133	133	133	133

Note: * mean default status.

■ FUNCTIONAL BLOCK DIAGRAM

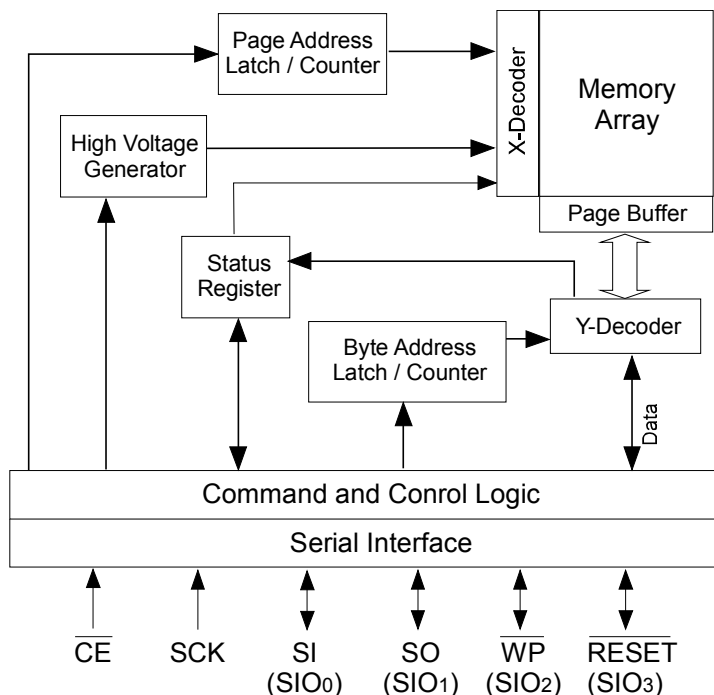

■ PIN CONFIGURATIONS

8-Lead SOIC / 8-Lead VSOP

(SOIC 8L, 208mil Body, 1.27mm Pin Pitch)

(SOIC 8L, 208mil Body with thickness 1.0mm, 1.27mm Pin Pitch)

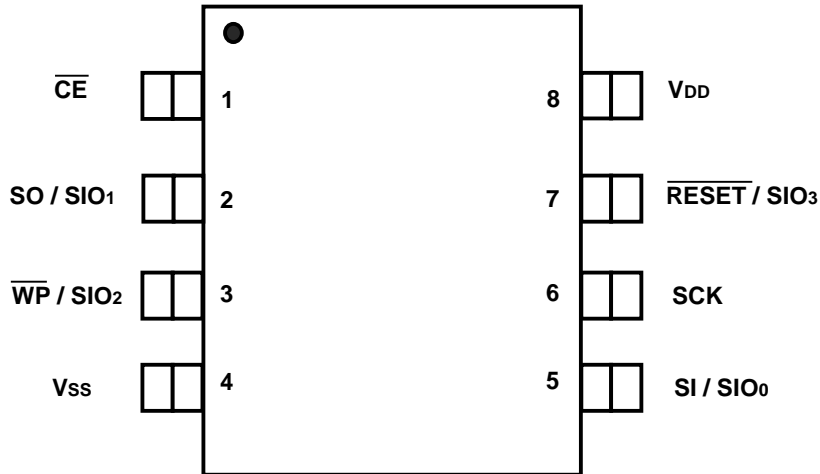

8- Contact WSON

(WSON 8C, 6mmX5mm Body, 1.27mm Contact Pitch)

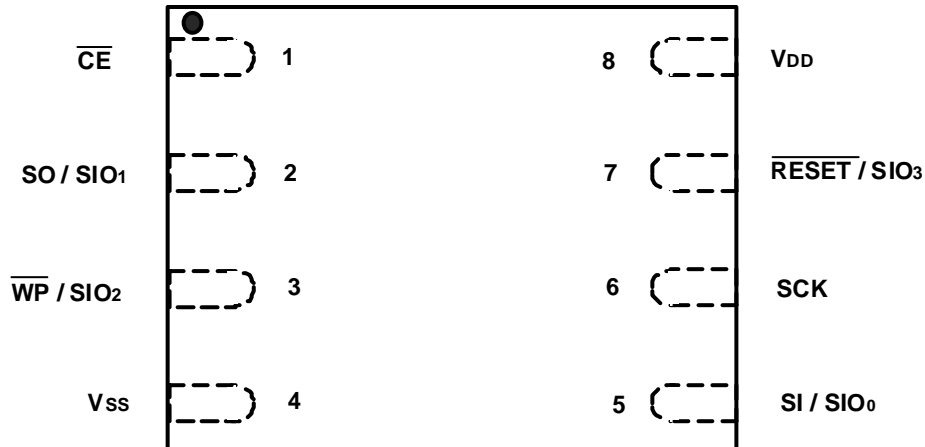

■ PIN DESCRIPTION

Symbol	Pin Name	Functions
SCK	Serial Clock	To provide the timing for serial input and output operations
SI / SIO ₀	Serial Data Input / Serial Data Input Output 0	To transfer commands, addresses or data serially into the device. Data is latched on the rising edge of SCK (for Standard read mode). / Bidirectional IO pin to transfer commands, addresses or data serially into the device on the rising edge of SCK and read data or status from the device on the falling edge of SCK(for Dual/Quad mode).
SO / SIO ₁	Serial Data Output / Serial Data Input Output 1	To transfer data serially out of the device. Data is shifted out on the falling edge of SCK (for Standard read mode). / Bidirectional IO pin to transfer commands, addresses or data serially into the device on the rising edge of SCK and read data or status from the device on the falling edge of SCK (for Dual/Quad mode).
$\overline{\text{CE}}$	Chip Enable	To activate the device when $\overline{\text{CE}}$ is low.
$\overline{\text{WP}}$ / SIO ₂	Write Protect / Serial Data Input Output 2	The Write Protect ($\overline{\text{WP}}$) pin is used to enable/disable BPL bit in the status register. / Bidirectional IO pin to transfer commands, addresses or data serially into the device on the rising edge of SCK and read data or status from the device on the falling edge of SCK (for Quad mode).
$\overline{\text{RESET}}$ / SIO ₃	Reset / Serial Data Input Output 3	Hardware Reset Pin Active low / Bidirectional IO pin to transfer commands, addresses or data serially into the device on the rising edge of SCK and read data or status from the device on the falling edge of SCK (for Quad mode).
VDD	Power Supply	To provide power.
VSS	Ground	

■ SECTOR STRUCTURE

Table 1: Sector Address Table

64KB Block	32KB Block	Sector	Sector Size (Kbytes)	Address range
255	511	4095	4KB	FFF000h – FFFFFFFh
		:	:	:
		4088	4KB	FF8000h – FF8FFFh
	510	4087	4KB	FF7000h – FF7FFFh
		:	:	:
		4080	4KB	FF0000h – FF0FFFh
254	509	4079	4KB	FEF000h – FFFFFFFh
		:	:	:
		4072	4KB	FE8000h – FE8FFFh
	508	4071	4KB	FE7000h – FE7FFFh
		:	:	:
		4064	4KB	FE0000h – FE0FFFh
253	507	4063	4KB	FDF000h – FFFFFFFh
		:	:	:
		4056	4KB	FD8000h – FD8FFFh
	506	4055	4KB	FD7000h – FD7FFFh
		:	:	:
		4048	4KB	FD0000h – FD0FFFh

individual
16 sectors
unit: 4KB

individual
block unit:
64KB



2	5	47	4KB	02F000h – 02FFFFh
		:	:	:
		40	4KB	028000h – 028FFFh
	4	39	4KB	027000h – 027FFFh
		:	:	:
1	3	32	4KB	020000h – 020FFFh
		31	4KB	01F000h – 01FFFFh
		:	:	:
	2	24	4KB	018000h – 018FFFh
		23	4KB	017000h – 017FFFh
		:	:	:
0	1	16	4KB	010000h – 010FFFh
		15	4KB	00F000h – 00FFFFh
		:	:	:
	0	8	4KB	008000h – 008FFFh
		7	4KB	007000h – 007FFFh
0	4KB	000000h – 000FFFh		

individual
16 sectors
unit: 4KB

■ STATUS REGISTER

The software status register provides status on whether the flash memory array is available for any Read or Write operation, whether the device is Write enabled, and the state of the memory Write protection. During an internal Erase or Program operation,

the status register may be read only to determine the completion of an operation in progress. Table 2 describes the function of each bit in the software status register.

Table 2: Software Status Register

Bit	Name	Function	Default at Power-up	Read/Write
Status Register				
0	BUSY	1 = Internal Write operation is in progress 0 = No internal Write operation is in progress	0	R
1	WEL	1 = Device is memory Write enabled 0 = Device is not memory Write enabled	0	R
2	BP0	Indicate current level of block write protection (See Table 3)	0	R/W
3	BP1	Indicate current level of block write protection (See Table 3)	0	R/W
4	BP2	Indicate current level of block write protection (See Table 3)	0	R/W
5	BP3	Indicate current level of block write protection (See Table 3)	0	R/W
6	QE	1 = Quad enabled 0 = Quad disabled	0	R/W
7	BPL	1 = BP3, BP2, BP1, BP0 are read-only bits 0 = BP3, BP2, BP1, BP0 are read/writable	0	R/W

Note: 1. BUSY and WEL are read only.

2. BP0~3, QE and BPL bits are non-volatile.

Write Enable Latch (WEL)

The Write-Enable-Latch bit indicates the status of the internal memory Write Enable Latch. If this bit is set to "1", it indicates the device is Write enabled. If the bit is set to "0" (reset), it indicates the device is not Write enabled and does not accept any memory Write (Program/ Erase) commands. This bit is automatically reset under the following conditions:

- Power-up
- $\overline{\text{RESET}}$ pin driven low
- Write Disable (WRDI) instruction completion
- Page Program (PP) instruction completion
- Sector Erase (SE) instruction completion
- Block Erase 32KB (BE32K) instruction completion
- Block Erase (BE) instruction completion
- Chip Erase (CE) instruction completion
- Write Status Register (WRSR) instruction completion
- Program/Erase Suspend
- Softreset instruction completion
- Write Security Register (WRSCUR) instruction completion
- Write Protection Register (WPSEL) instruction completion

BUSY

The BUSY bit determines whether there is an internal Erase or Program operation in progress. A "1" for the BUSY bit indicates the device is busy with an operation in progress. A "0" indicates the device is ready for the next valid operation.

Quad Enable (QE)

When the Quad Enable bit is reset to "0" (factory default), $\overline{\text{WP}}$ and $\overline{\text{RESET}}$ pins are enabled. When QE pin is set to "1", Quad SIO₂ and SIO₃ are enabled. (The QE should never be set to "1" during standard and Dual SPI operation if the $\overline{\text{WP}}$ and $\overline{\text{RESET}}$ pins are tied directly to the V_{DD} or V_{SS}.) When in QPI mode, QE bit is not required for setting.

Block Protection (BP3, BP2, BP1, BP0)

The Block-Protection (BP3, BP2, BP1, BP0) bits define the memory area, as defined in Table 3, to be software protected against any memory Write (Program or Erase) operations. The Write Status Register (WRSR) instruction is used to program the BP3, BP2, BP1 and BP0 bits as long as $\overline{\text{WP}}$ is high or the Block-Protection-Lock (BPL) bit is 0. Chip Erase can only be executed if BP3, BP2, BP1 and BP0 bits are all 0. The factory default setting for Block Protection Bit (BP3 ~ BP0) is 0.

Block Protection Lock-Down (BPL)

$\overline{\text{WP}}$ pin driven low (V_{IL}), enables the Block-Protection-Lock-Down (BPL) bit. When BPL is set to 1, it prevents any further alteration of the BPL, BP3, BP2, BP1 and BP0 bits. When the $\overline{\text{WP}}$ pin is driven high (V_{IH}), the BPL bit has no effect and its value is "Don't Care".

Table 3: Block Protection Table

Protection Level (TB bit =0)	Status Register Bit				Protected Memory Area
	BP3	BP2	BP1	BP0	64KB Block Range
0	0	0	0	0	None
Upper 1/256	0	0	0	1	Block 255
Upper 2/256	0	0	1	0	Block 254~255
Upper 4/256	0	0	1	1	Block 252~255
Upper 8/256	0	1	0	0	Block 248~255
Upper 16/256	0	1	0	1	Block 240~255
Upper 32/256	0	1	1	0	Block 224~255
Upper 64/256	0	1	1	1	Block 192~255
Upper 128/256	1	0	0	0	Block 128~255
All Blocks	1	0	0	1	Block 0~255
All Blocks	1	0	1	0	Block 0~255
All Blocks	1	0	1	1	Block 0~255
All Blocks	1	1	0	0	Block 0~255
All Blocks	1	1	0	1	Block 0~255
All Blocks	1	1	1	0	Block 0~255
All Blocks	1	1	1	1	Block 0~255

Protection Level (TB bit =1)	Status Register Bit				Protected Memory Area
	BP3	BP2	BP1	BP0	64KB Block Range
0	0	0	0	0	None
Bottom 1/256	0	0	0	1	Block 0
Bottom 2/256	0	0	1	0	Block 0~1
Bottom 4/256	0	0	1	1	Block 0~3
Bottom 8/256	0	1	0	0	Block 0~7
Bottom 16/256	0	1	0	1	Block 0~15
Bottom 32/256	0	1	1	0	Block 0~31
Bottom 64/256	0	1	1	1	Block 0~63
Bottom 128/256	1	0	0	0	Block 0~127
All Blocks	1	0	0	1	Block 0~255
All Blocks	1	0	1	0	Block 0~255
All Blocks	1	0	1	1	Block 0~255
All Blocks	1	1	0	0	Block 0~255
All Blocks	1	1	0	1	Block 0~255
All Blocks	1	1	1	0	Block 0~255
All Blocks	1	1	1	1	Block 0~255

■ CONFIGURATION REGISTER

The Configuration Register is able to change the default status of Flash memory. Flash memory will be configured after the CR bit is set.

Table 4: Configuration Register

Bit	Name	Function	Default at Power-up	Read/Write
Configuration Register				
0	ODS0	Output driver strength (See Table 5)	1	R/W
1	ODS1	Output driver strength (See Table 5)	1	R/W
2	ODS2	Output driver strength (See Table 5)	1	R/W
3	TB	0 = Top area protect 1 = Bottom area protect	0	R/W
4	Reserved	Reserved	-	-
5	Reserved	Reserved	-	-
6	DC0	Dummy cycle (See Table 6)	0	R/W
7	DC1	Dummy cycle (See Table 6)	0	R/W

Note: TB bit is non-volatile OTP bit.

ODS bit

The output driver strength (ODS2, ODS1, ODS0) bits are volatile bits, which indicate the output driver level (as defined in Output Driver Strength Table) of the device. The Output Driver Strength is defaulted as 30 Ohms when delivered from factory. To write the ODS bits requires the Write Status Register (WRSR) instruction to be executed.

TB bit

The Top/Bottom (TB) bit is a non-volatile OTP bit. The Top/Bottom (TB) bit is used to configure the Block Protect area by BP bit (BP3, BP2, BP1, BP0), starting from TOP or Bottom of the memory array. The TB bit is defaulted as "0", which means Top area protect. When it is set as "1", the protect area will change to Bottom area of the memory device. To write the TB bits requires the Write Status Register (WRSR) instruction to be executed.

Table 5: Output Driver Strength

ODS2	ODS1	ODS0	Description	Note
0	0	0	Reserved	Impedance at $V_{DD}/2$
0	0	1	90 Ohms	
0	1	0	60 Ohms	
0	1	1	45 Ohms	
1	0	0	30 Ohms	
1	0	1	20 Ohms	
1	1	0	15 Ohms	
1	1	1	Default	

Table 6: Dummy Cycle and Clock Frequency (MHz)

DC[1:0]	Numbers of Dummy clock cycles	Fast Read	Dual Output Fast Read	Quad Output Fast Read
01	6	104	104	84
10	8	104	104	104
11	10	133	133	133
00 (default)	8	104	104	104

DC[1:0]	Numbers of Dummy clock cycles	Dual IO Fast Read
01	6	104
10	8	104
11	10	133
00 (default)	4	104

DC[1:0]	Numbers of Dummy clock cycles	Quad IO Fast Read
01	4	70
10	8	104
11	10	133
00 (default)	6	84

■ **RESET OPERATION**

Driving the $\overline{\text{RESET}}$ pin low for a period of t_{RLRH} or longer will reset the device. After reset cycle, the device is at the following states:

- Standby mode
- All the volatile bits such as WEL/BUSY/BPL lock bit will return to the default status as power on.

$\overline{\text{RESET}}$ pin low will also terminate the operation and data could be lost. During the resetting cycle, the SO data becomes high impedance and the current will be reduced to minimum.

If the device is under programming or erasing, driving the

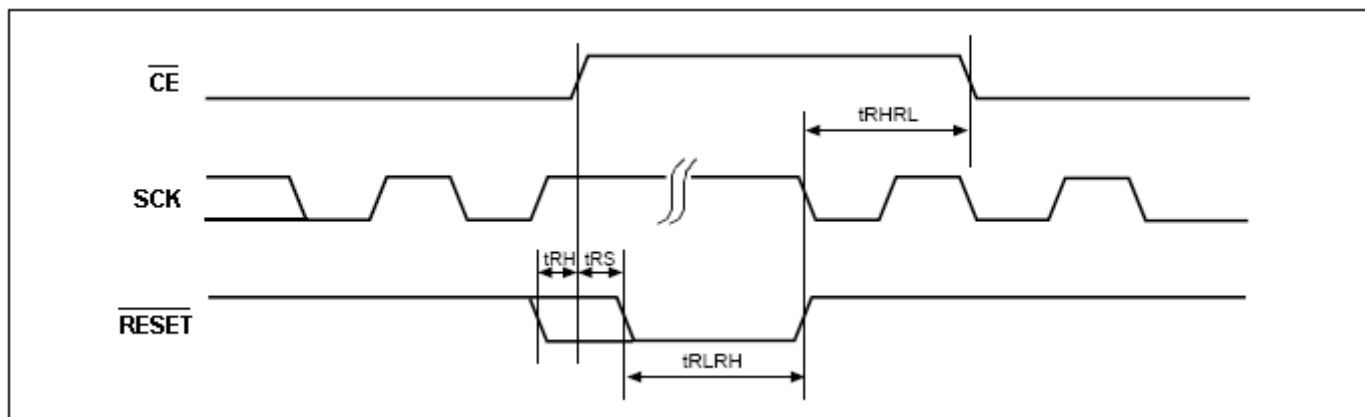

Figure 1: RESET Timing

■ **WRITE PROTECTION**

The device provides software Write Protection.

The Write-Protect pin ($\overline{\text{WP}}$) enables or disables the lock-down function of the status register. The Block-Protection bits (BP3, BP2, BP1, BP0 and BPL) in the status register provide Write protection to the memory array and the status register. When the QE bit of Status Register is set for Quad I/O or the system enter QPI mode, the $\overline{\text{WP}}$ pin function is not available since this pin is used for SIO₂.

Write Protect Pin ($\overline{\text{WP}}$)

The Write-Protect ($\overline{\text{WP}}$) pin enables the lock-down function of the BPL bit (bit 7) in the status register. When $\overline{\text{WP}}$ is driven low, the execution of the Write Status Register (WRSR) instruction is determined by the value of the BPL bit (see Table 7). When $\overline{\text{WP}}$ is high, the lock-down function of the BPL bit is disabled.

Table 7: Conditions to Execute Write Status Register (WRSR) Instruction

$\overline{\text{WP}}$	BPL	Execute WRSR Instruction
L	1	Not Allowed
L	0	Allowed
H	X	Allowed

Quad Peripheral Interface (QPI) Read Mode

QPI protocol enables user to take full advantage of Quad I/O Serial Flash by providing the Quad I/O interface in command cycles, address cycles and as well as data output cycles.

Enable QPI mode

By issuing 35H command, the QPI mode is enable.

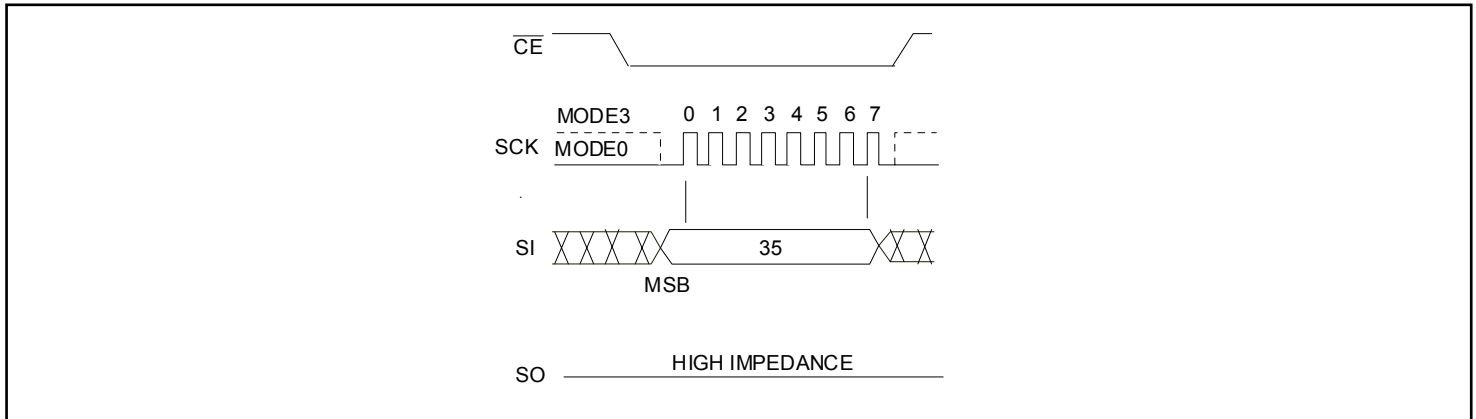

Quad Peripheral Interface (QPI) operation

To use QPI protocol, the host drives \overline{CE} low then sends the Fast Read command, 0BH, followed by 6 address cycles and 4 dummy cycles. Most significant bit (MSB) comes first (Please refer to Figure 9-2).

After the dummy cycle, the Quad Peripheral Interface (QPI) Flash Memory outputs data on the falling edge of the SCK signal starting from the specified address location. The device continually streams data output through all addresses until terminated by a low-to-high transition on \overline{CE} . The internal address pointer automatically increases until the highest memory address is reached. When reached the highest memory address, the address pointer returns to the beginning of the address space.

Reset QPI mode

By issuing F5H command, the device is reset to 1-I/O SPI mode.

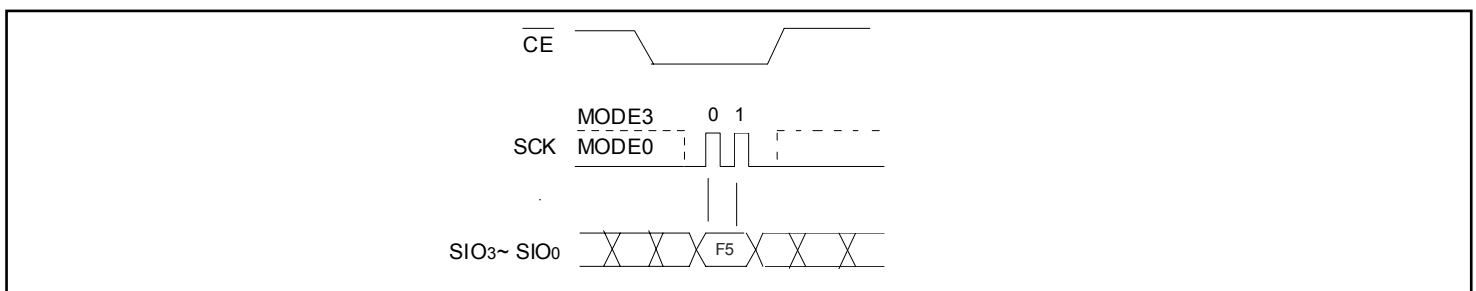

■ INSTRUCTIONS

Instructions are used to Read, Write (Erase and Program), and configure the F25D128QA. The instruction bus cycles are 8 bits each for commands (Op Code), data, and addresses. Prior to executing any Page Program, Write Status Register, Sector Erase, Block Erase, or Chip Erase instructions, the Write Enable (WREN) instruction must be executed first. The complete list of the instructions is provided in Table 8. All instructions are synchronized off a high to low transition of \overline{CE} . Inputs will be accepted on the rising edge of SCK starting with the most significant bit. \overline{CE} must be driven low before an instruction is

entered and must be driven high after the last bit of the instruction has been shifted in (except for Read, Read ID, Read Status Register, Read Electronic Signature instructions). Any low to high transition on \overline{CE} , before receiving the last bit of an instruction bus cycle, will terminate the instruction in progress and return the device to the standby mode.

Instruction commands (Op Code), addresses, and data are all input from the most significant bit (MSB) first.

Table 8-1: Device Operation Instruction (SPI)

Operation	SPI Bus Cycle ¹⁻³													
	1		2		3		4		5		6		N	
	S _{IN}	S _{OUT}	S _{IN}	S _{OUT}	S _{IN}	S _{OUT}	S _{IN}	S _{OUT}	S _{IN}	S _{OUT}	S _{IN}	S _{OUT}	S _{IN}	S _{OUT}
Read	03H	Hi-Z	A ₂₃ -A ₁₆	Hi-Z	A ₁₅ -A ₈	Hi-Z	A ₇ -A ₀	Hi-Z	X	D _{OUT0}	X	D _{OUT1}	X	cont.
Fast Read	0BH	Hi-Z	A ₂₃ -A ₁₆	Hi-Z	A ₁₅ -A ₈	Hi-Z	A ₇ -A ₀	Hi-Z	X	X	X	D _{OUT0}	X	cont.
Fast Read Dual I/O ^{12, 13} (2READ)	BBH	Hi-Z	A ₂₃ -A ₈		A ₇ -A ₀ , M ₇ -M ₀		D _{OUT0-1}		cont.		-		-	
Fast Read Quad I/O ¹⁴ (4 dummy cycles) (W4READ)	E7H	Hi-Z	A ₂₃ -A ₀ , M ₇ -M ₀		X, D _{OUT 0-2}		Cont.		-		-		-	
Fast Read Quad I/O ^{12, 14} (4READ)	EBH	Hi-Z	A ₂₃ -A ₀ , M ₇ -M ₀		X, D _{OUT0-1}		D _{OUT2-6}		cont.		-		-	
Sector Erase ⁴ - 4KB (SE)	20H	Hi-Z	A ₂₃ -A ₁₆	Hi-Z	A ₁₅ -A ₈	Hi-Z	A ₇ -A ₀	Hi-Z	-	-	-	-	-	-
Block Erase 32KB ⁵ (BE32K)	52H	Hi-Z	A ₂₃ -A ₁₆	Hi-Z	A ₁₅ -A ₈	Hi-Z	A ₇ -A ₀	Hi-Z	-	-	-	-	-	-
Block Erase ⁵ (BE)	D8H	Hi-Z	A ₂₃ -A ₁₆	Hi-Z	A ₁₅ -A ₈	Hi-Z	A ₇ -A ₀	Hi-Z	-	-	-	-	-	-
Chip Erase (CE)	60H / C7H	Hi-Z	-	-	-	-	-	-	-	-	-	-	-	-
Program / Erase Suspend	B0H	Hi-Z	-	-	-	-	-	-	-	-	-	-	-	-
Program / Erase Resume	30H	Hi-Z	-	-	-	-	-	-	-	-	-	-	-	-
Page Program (PP)	02H	Hi-Z	A ₂₃ -A ₁₆	Hi-Z	A ₁₅ -A ₈	Hi-Z	A ₇ -A ₀	Hi-Z	D _{IN0}	Hi-Z	D _{IN1}	Hi-Z	Up to 256 bytes	Hi-Z
Quad Page Program (4PP) ¹⁵	38h	Hi-Z	A ₂₃ ~A ₀ , D _{IN 0}		D _{IN 1-4}		D _{IN 5-8}		D _{IN 9-12}		D _{IN 13-16}		Up to 256 byte	
Mode Bit Reset ¹⁶	FFH	Hi-Z	-	-	-	-	-	-	-	-	-	-	-	-
Read Status Register (RDSR) ⁷	05H	Hi-Z	X	D _{OUT} (S ₇₋₀)	-	-	-	-	-	-	-	-	-	-
Read Configuration Register (RDCR) ⁷	15H	Hi-Z	X	D _{OUT} (C ₇₋₀)	-	-	-	-	-	-	-	-	-	-
Write Status/Configuration Register (WRSR) ¹⁰	01H	Hi-Z	D _{IN} (S ₇₋₀)	Hi-Z	D _{OUT} (C ₇₋₀)	Hi-Z	-	-	-	-	-	-	-	-
Write Enable (WREN) ¹⁰	06H	Hi-Z	-	-	-	-	-	-	-	-	-	-	-	-
Write Disable (WRDI)	04H	Hi-Z	-	-	-	-	-	-	-	-	-	-	-	-
Read Electronic Signature (RES) ⁸	ABH	Hi-Z	X	X	X	X	X	X	X	38H	-	-	-	-
RES in secured OTP mode & not lock down	ABH	Hi-Z	X	X	X	X	X	X	X	78H	-	-	-	-
RES in secured OTP mode & lock down	ABH	Hi-Z	X	X	X	X	X	X	X	F8H	-	-	-	-
Read ID (RDID) ⁹	9FH	Hi-Z	X	8CH	X	25H	X	38h	-	-	-	-	-	-

Table 8-1: Device Operation Instruction (SPI) - Continued

Operation	SPI Bus Cycle ¹⁻³													
	1		2		3		4		5		6		N	
	S _{IN}	S _{OUT}	S _{IN}	S _{OUT}	S _{IN}	S _{OUT}	S _{IN}	S _{OUT}	S _{IN}	S _{OUT}	S _{IN}	S _{OUT}	S _{IN}	S _{OUT}
Read Electronic ID (REMS) ¹¹	90H	Hi-Z	00H	Hi-Z	00H	Hi-Z	00H	Hi-Z	X	8CH	X	38H	-	-
									X	38H	X	8CH	-	-
Read SFDP (RDSFDP)	5AH	Hi-Z	A ₂₃ -A ₁₆	Hi-Z	A ₁₅ -A ₈	Hi-Z	A ₇ -A ₀	Hi-Z	X	X	X	D _{OUT0}	X	cont.
Deep Power Down (DP)	B9H	Hi-Z	-	-	-	-	-	-	-	-	-	-	-	-
Release from Deep Power Down (RDP)	ABH	Hi-Z	-	-	-	-	-	-	-	-	-	-	-	-
Enter secured OTP mode (ENSO)	B1H	Hi-Z	-	-	-	-	-	-	-	-	-	-	-	-
Exit OTP (EXSO)	C1H	Hi-Z	-	-	-	-	-	-	-	-	-	-	-	-
Read Security Register (RDSCUR)	2BH	Hi-Z	X	D _{OUT}	-	-	-	-	-	-	-	-	-	-
Write Security Register (WRSCUR)	2FH	Hi-Z	-	-	-	-	-	-	-	-	-	-	-	-
Reset Enable (RSTEN)	66H	Hi-Z	-	-	-	-	-	-	-	-	-	-	-	-
Reset Memory (RST) ⁶	99H	Hi-Z	-	-	-	-	-	-	-	-	-	-	-	-
Single Block Lock (SBLK)	36H	Hi-Z	A ₂₃ -A ₁₆	Hi-Z	A ₁₅ -A ₈	Hi-Z	A ₇ -A ₀	Hi-Z	-	-	-	-	-	-
Single Block Unlock (SBULK)	39H	Hi-Z	A ₂₃ -A ₁₆	Hi-Z	A ₁₅ -A ₈	Hi-Z	A ₇ -A ₀	Hi-Z	-	-	-	-	-	-
Block Protect Read (RDBLOCK)	3CH	Hi-Z	A ₂₃ -A ₁₆	Hi-Z	A ₁₅ -A ₈	Hi-Z	A ₇ -A ₀	Hi-Z	-	-	-	-	-	-
Gang Block Lock (GBLK)	7EH	Hi-Z	-	-	-	-	-	-	-	-	-	-	-	-
Gang Block Unlock (GBULK)	98H	Hi-Z	-	-	-	-	-	-	-	-	-	-	-	-
Write Protect Selection (WPSEL)	68H	Hi-Z	-	-	-	-	-	-	-	-	-	-	-	-
Set Burst Length (SBL)	C0H	Hi-Z	D _{IN}	Hi-Z	-	-	-	-	-	-	-	-	-	-
Enable Quad I/O (EQIO)	35H	Hi-Z	-	-	-	-	-	-	-	-	-	-	-	-
Read Unique ID Number	4BH	Hi-Z	X	X	X	X	X	X	X	X	X	D _{OUT0}	X	cont.
NOP	00H	Hi-Z	-	-	-	-	-	-	-	-	-	-	-	-

Table 8-2: Device Operation Instruction (QPI)

Operation	QPI Bus Cycle ¹⁻³								
	1	2	3	4	5	6	7	8	N
	S _{IO}	S _{IO}	S _{IO}	S _{IO}	S _{IO}	S _{IO}	S _{IO}	S _{IO}	S _{IO}
Fast Read	0BH	A _{23-A16}	A _{15-A8}	A _{7-A0}	X	X	D _{OUT0}	D _{OUT1}	cont.
Fast Read Quad I/O ^{12, 14} (4READ)	EBH	A _{23-A16}	A _{15-A8}	A _{7-A0}	M _{7-M0}	X	X	D _{OUT0}	cont.
Sector Erase ⁴ - 4KB (SE)	20H	A _{23-A16}	A _{15-A8}	A _{7-A0}	-	-	-	-	-
Block Erase 32KB ⁵ (BE32K)	52H	A _{23-A16}	A _{15-A8}	A _{7-A0}	-	-	-	-	-
Block Erase ⁵ (BE)	D8H	A _{23-A16}	A _{15-A8}	A _{7-A0}	-	-	-	-	-
Chip Erase (CE)	60H / C7H	-	-	-	-	-	-	-	-
Program / Erase Suspend	B0H	-	-	-	-	-	-	-	-
Program / Erase Resume	30H	-	-	-	-	-	-	-	-
Page Program (PP)	02H	A _{23-A16}	A _{15-A8}	A _{7-A0}	D _{IN0}	D _{IN1}	D _{IN2}	D _{IN3}	Up to 256 bytes
Mode Bit Reset ¹⁶	FFH	FFH	FFH	FFH	-	-	-	-	-
Read Status Register (RDSR) ⁷	05H	D _{OUT} (S ₇₋₀)	-	-	-	-	-	-	-
Read Configuration Register (RDCR) ⁷	15H	D _{OUT} (C ₇₋₀)	-	-	-	-	-	-	-
Write Status/Configuration Register (WRSR) ¹⁰	01H	D _{IN} (S ₇₋₀)	D _{OUT} (C ₇₋₀)	-	-	-	-	-	-
Write Enable (WREN) ¹⁰	06H	-	-	-	-	-	-	-	-
Write Disable (WRDI)	04H	-	-	-	-	-	-	-	-
Read Electronic Signature (RES) ⁸	ABH	X	X	X	38H	-	-	-	-
RES in secured OTP mode & not lock down	ABH	X	X	X	78H	-	-	-	-
RES in secured OTP mode & lock down	ABH	X	X	X	F8H	-	-	-	-
Read SFDP (RDSFDP)	5AH	A _{23-A16}	A _{15-A8}	A _{7-A0}	X	X	D _{OUT0}	D _{OUT1}	cont.
Deep Power Down (DP)	B9H	-	-	-	-	-	-	-	-
Release from Deep Power Down (RDP)	ABH	-	-	-	-	-	-	-	-
Exit OTP (EXSO)	C1H	-	-	-	-	-	-	-	-
Enter secured OTP mode (ENSO)	B1H	-	-	-	-	-	-	-	-
Read Security Register (RDSCUR)	2BH	D _{OUT}	-	-	-	-	-	-	-
Write Security Register (WRSCUR)	2FH	-	-	-	-	-	-	-	-
Reset Enable (RSTEN)	66H	-	-	-	-	-	-	-	-
Reset Memory (RST) ⁶	99H	-	-	-	-	-	-	-	-
Single Block Lock (SBLK)	36H	A _{23-A16}	A _{15-A8}	A _{7-A0}	-	-	-	-	-
Single Block Unlock (SBULK)	39H	A _{23-A16}	A _{15-A8}	A _{7-A0}	-	-	-	-	-
Block Protect Read (RDBLOCK)	3CH	A _{23-A16}	A _{15-A8}	A _{7-A0}	-	-	-	-	-
Gang Block Lock (GBLK)	7EH	-	-	-	-	-	-	-	-
Gang Block Unlock (GBULK)	98H	-	-	-	-	-	-	-	-
Write Protect Selection (WPSEL)	68H	-	-	-	-	-	-	-	-
Set Burst Length (SBL)	C0H	D _{IN}	-	-	-	-	-	-	-
QPI ID Read (QPIID) ⁹	AFH	8CH	25H	38H	-	-	-	-	-
Reset QPI (RSTQIO)	F5H	-	-	-	-	-	-	-	-
NOP	00H	-	-	-	-	-	-	-	-

Notes:

1. Operation: S_{IN} = Serial In, S_{OUT} = Serial Out, S_{IO} = Serial In/Out.

2. X = Dummy Input Cycles (V_{IL} or V_{IH}), dummy cycle numbers will be different depending on the bit6 & bit7 (DC0 & DC1) setting in Configuration Register; - = Non-Applicable Cycles (Cycles are not necessary); cont. = continuous
3. One SPI bus cycle is eight clock periods; one QPI bus cycle is two clock periods.
4. 4K byte Sector Erase addresses: use $A_{MS} - A_{12}$, remaining addresses can be V_{IL} or V_{IH} .
5. 32K byte Block Erase addresses: use $A_{MS} - A_{15}$, remaining addresses can be V_{IL} or V_{IH}
6. 64K byte Block Erase addresses: use $A_{MS} - A_{16}$, remaining addresses can be V_{IL} or V_{IH}
6. RST command only executed if RSTEN command is executed first. Any intervening command will disable Reset.
7. The Read Status Register / Read Configuration Register is continuous with ongoing clock cycles until terminated by a low to high transition on \overline{CE} .
8. The Read Electronic Signature is continuous with on going clock cycles until terminated by a low to high transition on \overline{CE} .
9. The Read ID is output first byte 8CH as manufacture ID; second byte 25H as memory type; third byte 38H as memory capacity.
10. The Write Enable (WREN) instruction and the Write Status Register (WRSR) instruction must work in conjunction of each other. The WRSR instruction must be executed immediately (very next bus cycle) after the WREN instruction to make both instructions effective. A successful WRSR can reset WREN.
11. The Manufacture ID and Device ID output will repeat continuously until \overline{CE} terminates the instruction.
12. Dual and Quad commands use bidirectional IO pins. D_{OUT} and cont. are serial data out; others are serial data in.
13. $M_7 - M_0$: Mode bits. Dual input address:

$IO_0 = (A_{22}, A_{20}, A_{18}, A_{16}, A_{14}, A_{12}, A_{10}, A_8)$	$(A_6, A_4, A_2, A_0, M_6, M_4, M_2, M_0)$
$IO_1 = (A_{23}, A_{21}, A_{19}, A_{17}, A_{15}, A_{13}, A_{11}, A_9)$	$(A_7, A_5, A_3, A_1, M_7, M_5, M_3, M_1)$
} Bus Cycle-2	} Bus Cycle-3

14. $M_7 - M_0$: Mode bits. Quad input address:

$IO_0 = (A_{20}, A_{16}, A_{12}, A_8, A_4, A_0, M_4, M_0)$
$IO_1 = (A_{21}, A_{17}, A_{13}, A_9, A_5, A_1, M_5, M_1)$
$IO_2 = (A_{22}, A_{18}, A_{14}, A_{10}, A_6, A_2, M_6, M_2)$
$IO_3 = (A_{23}, A_{19}, A_{15}, A_{11}, A_7, A_3, M_7, M_3)$
} Bus Cycle-2

Fast Read Quad I/O data:

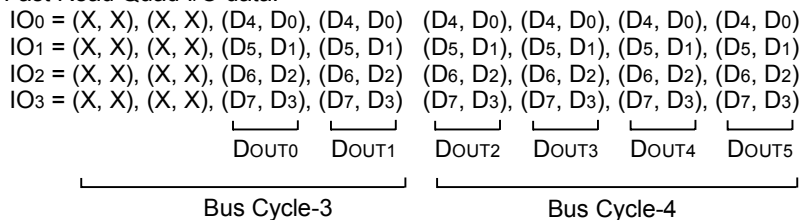

15. The instruction is initiated by executing command code, and then input data to bidirectional IO pins ($SIO_0 \sim SIO_3$). Quad input address and data:

$IO_0 = (A_{20}, A_{16}, A_{12}, A_8, A_4, A_0, D_4, D_0)$
$IO_1 = (A_{21}, A_{17}, A_{13}, A_9, A_5, A_1, D_5, D_1)$
$IO_2 = (A_{22}, A_{18}, A_{14}, A_{10}, A_6, A_2, D_6, D_2)$
$IO_3 = (A_{23}, A_{19}, A_{15}, A_{11}, A_7, A_3, D_7, D_3)$
} SPI Bus Cycle
16. This instruction is recommended when using the Dual or Quad Mode bit feature.

(1) Write Enable (WREN)

The Write Enable (WREN) instruction is for setting Write Enable Latch (WEL) bit. For those instructions like PP, 4PP, SE, BE32K, BE, CE, and WRSR, which are intended to change the device content WEL bit should be set every time after the WREN instruction setting the WEL bit.

The sequence of issuing WREN instruction is: \overline{CE} goes low → sending WREN instruction code → \overline{CE} goes high.
(Please refer to Figure 2-1 and Figure 2-2)

(2) Write Disable (WRDI)

The Write Disable (WRDI) instruction is to reset Write Enable Latch (WEL) bit.

The sequence of issuing WRDI instruction is: \overline{CE} goes low → sending WRDI instruction code → \overline{CE} goes high.
(Please refer to Figure 3-1 and Figure 3-2)

The WEL bit is reset by following situations:

- Power-up
- Completion of Write Disable (WRDI) instruction
- Completion of Write Status Register (WRSR) instruction
- Completion of Page Program (PP) instruction
- Completion of Quad Page Program (4PP) instruction
- Completion of Sector Erase (SE) instruction
- Completion of Block Erase 32KB (BE32K) instruction
- Completion of Block Erase (BE) instruction
- Completion of Chip Erase (CE) instruction
- Program/Erase Suspend

(3) Read Identification (RDID)

The RDID instruction is to read the manufacturer ID of 1-byte and followed by Device ID of 2-byte. The ESMT Manufacturer ID is 8CH, the memory type ID is 25H as the first-byte device ID, and the individual device ID of second-byte ID are listed as table of "ID Definitions".
(Please refer to Table 10)

The sequence of issuing RDID instruction is: \overline{CE} goes low → sending RDID instruction code → 24-bits ID data out on SO → to end RDID operation can drive \overline{CE} to high at any time during data out.

While Program/Erase operation is in progress, it will not decode the RDID instruction, therefore there's no effect on the cycle of program/erase operation which is currently in progress. When \overline{CE} goes high, the device is at standby stage. (Please refer Figure 4)

(4) Read Status Register (RDSR)

The RDSR instruction is for reading Status Register Bits. The Read Status Register can be read at any time (even in program/erase/write status register condition). It is recommended to check the BUSY bit before sending a new instruction when a program, erase, or write status register operation is in progress.

The sequence of issuing RDSR instruction is: \overline{CE} goes low → sending RDSR instruction code → Status Register data out on SO.
(Please refer to Figure 5-1 and Figure 5-2)

(5) Read Configuration Register (RDCR)

The RDCR instruction is for reading Configuration Register Bits. The Read Configuration Register can be read at any time (even in program/erase/write configuration register condition). It is recommended to check the BUSY bit before sending a new instruction when a program, erase, or write configuration register operation is in progress.

The sequence of issuing RDCR instruction is: \overline{CE} goes low → sending RDCR instruction code → Configuration Register data out on SO.

(Please refer to Figure 6-1 and Figure 6-2)

For user to check if Program/Erase operation is finished or not, RDCR instruction flow are shown as follows:

Program / Erase Flow with read array data

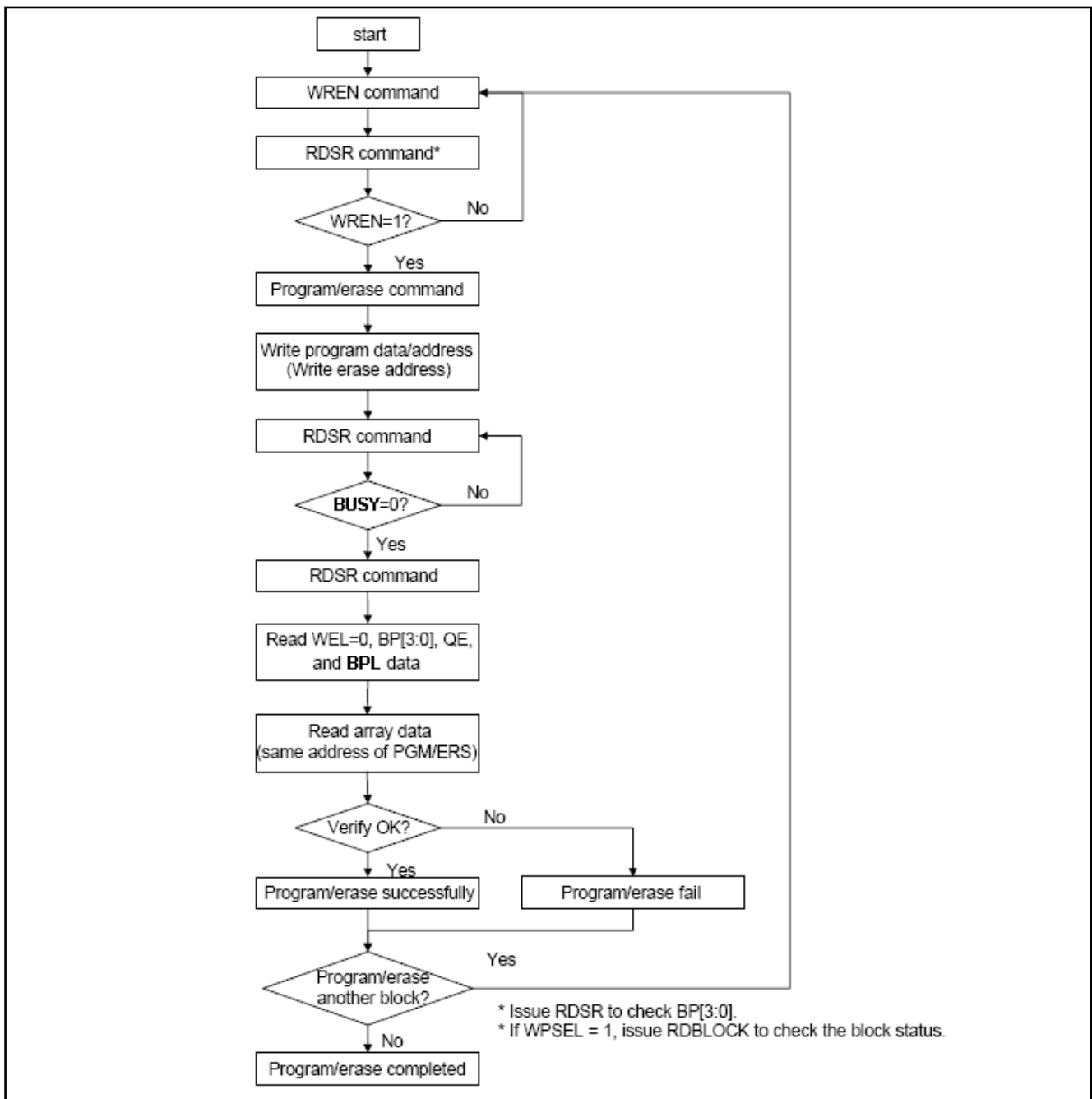

Program / Erase Flow without read array data (read P_FAIL/E_FAIL flag)

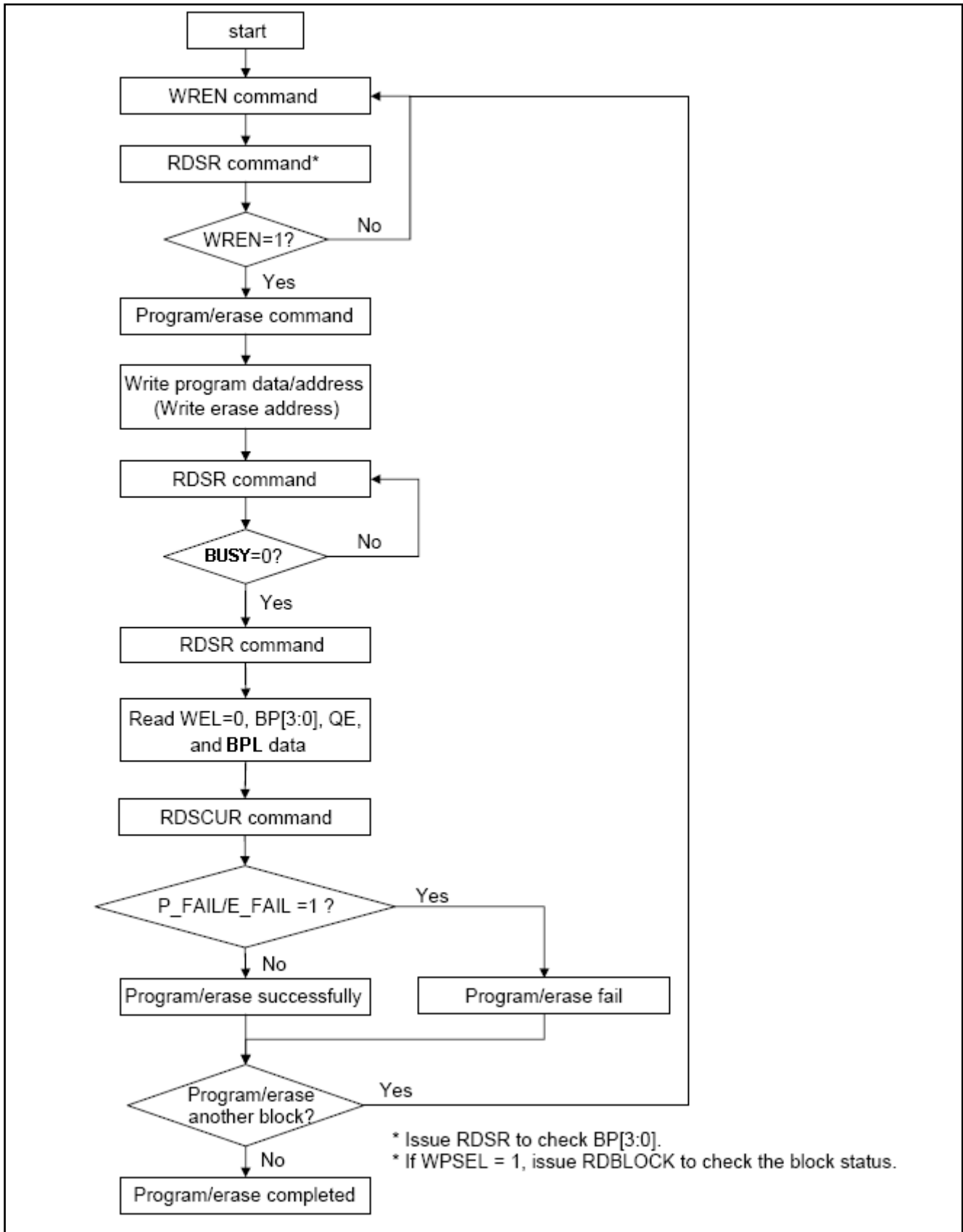

(5) Write Status Register (WRSR)

The WRSR instruction is for changing the values of Status Register Bits and Configuration Register Bits. Before sending WRSR instruction, the Write Enable (WREN) instruction must be decoded and executed to set the Write Enable Latch (WEL) bit in advance. The WRSR instruction can change the value of Block Protect (BP3, BP2, BP1, BP0) bits to define the protected area of memory (as shown in Table 3). The WRSR also can set or reset the Quad enable (QE) bit and set or reset the Block Protection Lock-Down (BPL) bit in accordance with Write Protection (\overline{WP} /SIO2) pin signal, but has no effect on bit1(WEL) and bit0 (BUSY) of the status register. The WRSR instruction cannot be executed once the Hardware Protected Mode (HPM) is entered.

If \overline{RESET} goes low while Write Status Register (WRSR) execution is on going, the operation of WRSR will finish after T_w timing before entering Reset mode.

The sequence of issuing WRSR instruction is: \overline{CE} goes low→ sending WRSR instruction code→ Status Register data on SI→ \overline{CE} goes high. (Please refer to Figure 7-1 and Figure 7-2)

The \overline{CE} must go high exactly at the byte boundary; otherwise, the instruction will be rejected and not executed. The self-timed Write Status Register cycle time (t_w) is initiated as soon as Chip Enable (\overline{CE}) goes high. The BUSY bit still can be check out during the Write Status Register cycle is in progress. The BUSY sets 1 during the t_w timing, and sets 0 when Write Status Register Cycle is completed, and the Write Enable Latch (WEL) bit is reset.

Table 9. Protection Modes

Mode	Status register condition	\overline{WP} and BPL bit status	Memory
Software protection mode (SPM)	Status register can be written in (WEL bit is set to "1") and the BPL, BP0-BP3 bits can be changed	$\overline{WP} = 1$ and BPL bit=0, or $\overline{WP} = 0$ and BPL bit=0, or $\overline{WP} = 1$ and BPL=1	The protected area cannot be program or erase.
Hardware protection mode (HPM)	The BPL, BP0-BP3 of status register bits cannot be changed	$\overline{WP} = 0$, BPL bit=1	The protected area cannot be program or erase.

Note: As defined by the values in the Block Protect (BP3, BP2, BP1, BP0) bits of the Status Register, as shown in Table 3.

As the above table showing, the summary of the Software Protected Mode (SPM) and Hardware Protected Mode (HPM).

Software Protected Mode (SPM):

- When BPL bit=0, no matter \overline{WP} /SIO₂ is low or high, the WREN instruction may set the WEL bit and can change the values of BPL, BP3, BP2, BP1, BP0. The protected area, which is defined by BP3, BP2, BP1, BP0, is at software protected mode (SPM).
- When BPL bit=1 and \overline{WP} /SIO₂ is high, the WREN instruction may set the WEL bit can change the values of BPL, BP3, BP2, BP1, BP0. The protected area, which is defined by BP3, BP2, BP1, BP0, is at software protected mode (SPM).

Note:

If BPL bit=1 but \overline{WP} /SIO₂ is low, it is impossible to write the Status Register even if the WEL bit has previously been set. It is rejected to write the Status Register and not be executed.

Hardware Protected Mode (HPM):

- When BPL bit=1, and then \overline{WP} /SIO₂ is low (or \overline{WP} /SIO₂ is low before BPL bit=1), it enters the hardware protected mode (HPM). The data of the protected area is protected by software protected mode by BP3, BP2, BP1, BP0 and hardware protected mode by the \overline{WP} /SIO₂ to against data modification.

Note:

To exit the hardware protected mode requires \overline{WP} /SIO₂ driving high once the hardware protected mode is entered. If the \overline{WP} /SIO₂ pin is permanently connected to high, the hardware protected mode can never be entered; only can use software protected mode via BP3, BP2, BP1, BP0. If the system set QE=1, the feature of HPM will be disabled.

(6) Read Data Bytes (READ)

The read instruction is for reading data out. The address is latched on rising edge of SCK, and data shifts out on the falling edge of SCK at a maximum frequency F_{RSCLK} . The first address byte can be at any location. The address is automatically increased to the next higher address after each byte data is shifted out, so the whole memory can be read out at a single READ instruction. The address counter rolls over to 0 when the highest address has been reached.

The sequence of issuing READ instruction is: \overline{CS} goes low → sending READ instruction code → 3-byte address on SI → data out on SO → to end READ operation can use \overline{CS} to high at any time during data out. (Please refer to Figure 8)

(7) Read Data Bytes at Higher Speed (FAST_READ)

The Fast Read instruction is for quickly reading data out. The address is latched on rising edge of SCK, and data of each bit shifts out on the falling edge of SCK at a maximum frequency F_{SCLK} . The first address byte can be at any location. The address is automatically increased to the next higher address after each byte data is shifted out, so the whole memory can be read out at a single Fast Read instruction. The address counter rolls over to 0 when the highest address has been reached.

SPI mode

The sequence of issuing Fast Read instruction is: \overline{CE} goes low → sending Fast Read instruction code → 3-byte address on SI → 1-dummy byte (default) address on SI → data out on SO → to end Fast Read operation can use \overline{CE} to high at any time during data out. (Please refer to Figure 9-1)

QPI mode

The sequence of issuing Fast Read instruction is: \overline{CE} goes low → sending Fast Read instruction code, 2 cycle → 24-bit address on $SIO_3 \sim SIO_0$ → 4 dummy cycle → data out interleave on $SIO_3 \sim SIO_0$ → to end QPI Fast Read operation can use \overline{CE} to high at any time during data out. (Please refer to Figure 9-2)

In the performance-enhancing mode, M[7:4] must be toggling with M[3:0] ; likewise M[7:0]=A5h, 5Ah, F0h or 0Fh can make this mode continue and reduce the next 4READ instruction. Once M[7:4] is no longer toggling with M[3:0]; likewise M[7:0]=FFh, 00h, AAh or 55h and afterwards \overline{CE} is raised and then lowered, the system then will escape from performance enhance mode and return to normal operation.

While Program/Erase/Write Status Register cycle is in progress, Fast Read instruction is rejected without any impact on the Program/Erase/Write Status Register current cycle.

(8) Fast Read Dual I/O (2READ)

The 2READ instruction enable double throughput of Serial Flash in read mode. The address is latched on rising edge of SCK, and data of every two bits (interleave on 2 I/O pins) shift out on the falling edge of SCK at a maximum frequency F_{TSCLK1} . The first address byte can be at any location. The address is automatically increased to the next higher address after each byte data is shifted out, so the whole memory can be read out at a single 2READ instruction. The address counter rolls over to 0 when the highest address has been reached. Once writing 2READ instruction, the following address/dummy/data out will perform as 2-bit instead of previous 1-bit.

The sequence of issuing 2READ instruction is: \overline{CE} goes low → sending 2READ instruction → 24-bit address interleave on SIO_1 & SIO_0 → 4 dummy cycles on SIO_1 & SIO_0 → data out interleave on SIO_1 & SIO_0 → to end 2READ operation can use \overline{CE} to high at any time during data out (Please refer to Figure 10).

While Program/Erase/Write Status Register cycle is in progress, 2READ instruction is rejected without any impact on the Program/Erase/Write Status Register current cycle.

(9) Fast Read Quad I/O (4READ)

The 4READ instruction enable quad throughput of Serial Flash in read mode. A Quad Enable (QE) bit of status Register must be set to "1" before sending the 4READ instruction. The address is latched on rising edge of SCK, and data of every four bits (interleave on 4 I/O pins) shift out on the falling edge of SCK at a maximum frequency F_{TCLK2} . The first address byte can be at any location. The address is automatically increased to the next higher address after each byte data is shifted out, so the whole memory can be read out at a single 4READ instruction. The address counter rolls over to 0 when the highest address has been reached. Once writing 4READ instruction, the following address/dummy/data out will perform as 4-bit instead of previous 1-bit.

SPI mode

The sequence of issuing 4READ instruction is: \overline{CE} goes low → sending 4READ instruction → 24-bit address interleave on $SIO_3, \sim SIO_0$ → 2+4 dummy cycles → data out interleave on SIO_3, SIO_2, SIO_1 & SIO_0 → to end 4READ operation can use \overline{CE} to high at any time during data out. (Please refer to Figure 11-1)

W4READ instruction (E7) is also available is SPI mode for 4 I/O read. The sequence is similar to 4READ, but with only 4 dummy cycles. The clock rate runs at 84MHz.

QPI mode

The sequence of issuing 4READ instruction is: \overline{CE} goes low → sending 4READ instruction → 24-bit address interleave on $SIO_3 \sim SIO_0$ → 2+4 dummy cycles → data out interleave on $SIO_3 \sim SIO_0$ → to end 4READ operation can use \overline{CE} to high at any time during data out. (Please refer to Figure 11-2)

Another sequence of issuing 4 READ instruction especially useful in random access is : \overline{CE} goes low → sending 4READ instruction → 3-bytes address interleave on SIO_3, SIO_2, SIO_1 & SIO_0 → performance enhance toggling bit $M[7:0]$ → 4 dummy cycles → data out still \overline{CE} goes high → \overline{CE} goes low (reduce 4 Read instruction) → 24-bit random access address (Please refer to Figure 23).

In the performance-enhancing mode, $M[7:4]$ must be toggling with $M[3:0]$; likewise $M[7:0]=A5h, 5Ah, F0h$ or $0Fh$ can make this mode continue and reduce the next 4READ instruction. Once $M[7:4]$ is no longer toggling with $M[3:0]$; likewise $M[7:0]=FFh, 00h, AAh$ or $55h$ and afterwards \overline{CE} is raised and then lowered, the system then will escape from performance enhance mode and return to normal operation.

While Program/Erase/Write Status Register cycle is in progress, 4READ instruction is rejected without any impact on the Program/Erase/Write Status Register current cycle.

(10) Burst Read

The device supports Burst Read in both SPI and QPI mode. To set the Burst length, following command operation is required Issuing command: “C0h” in the first Byte (8-clocks), following 4 clocks defining wrap around enable with “0h” and disable with “1h”.

Next 4 clocks is to define wrap around depth. Definition as following table:

Data	Wrap Around	Wrap Depth	Data	Wrap Around	Wrap Depth
1xh	No	X	00h	Yes	8-byte
1xh	No	X	01h	Yes	16-byte
1xh	No	X	02h	Yes	32-byte
1xh	No	X	03h	Yes	64-byte

The wrap around unit is defined within the 256-byte page, with random initial address. It's defined as “wrap-around mode disable” for the default state of the device. To exit wrap around, it is required to issue another “C0” command in which data=“1xh”. Otherwise, wrap around status will be retained until power down or reset command. To change wrap around depth, it is required to issue another “C0” command in which data=“0xh”. QPI “0Bh” “EBh” and SPI “EBh” “E7h” support wrap around feature after wrap around enable. The device id default without Burst read.

SPI Mode

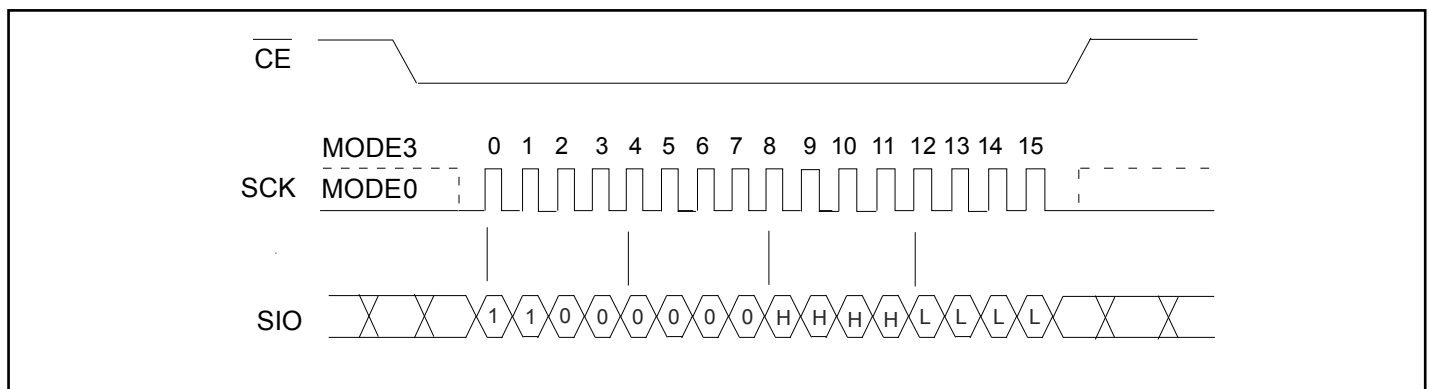

QPI Mode

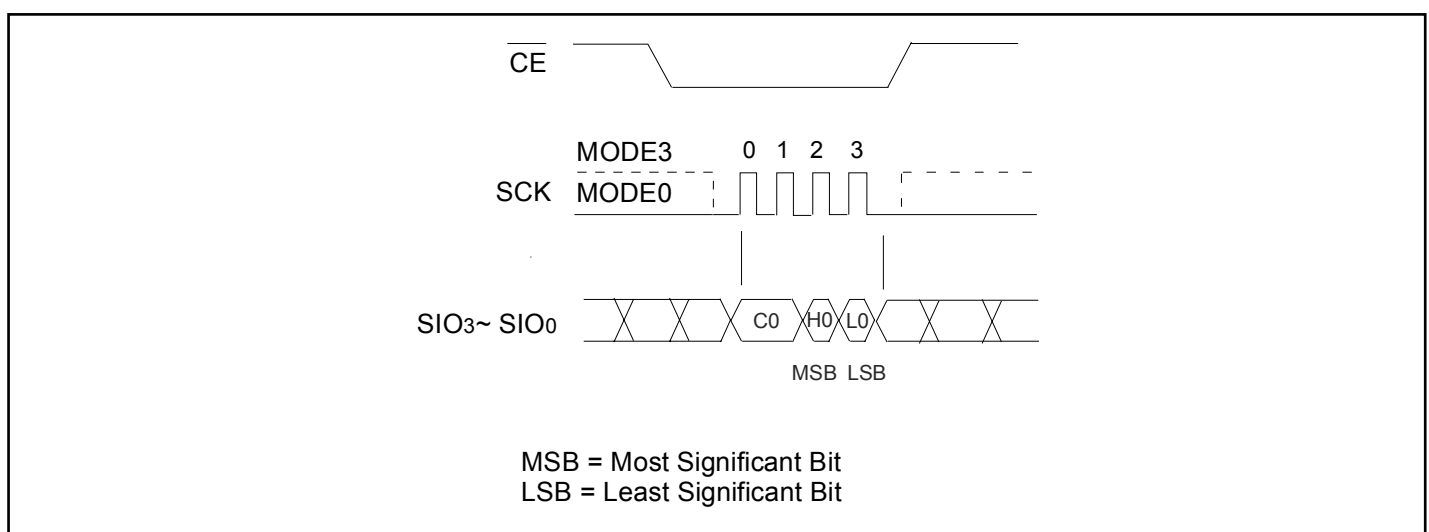

(11) Performance Enhance Mode

The device could waive the command cycle bits if the two cycle bits after address cycle toggles. (Please note Figure 12-1 and Figure 12-2)

Performance enhance mode is supported in both SPI and QPI mode. In QPI mode, "EBh" "0Bh" and SPI "EBh" "E7h" commands support enhance mode. The performance enhance mode is not supported in dual I/O mode.

After entering enhance mode, following \overline{CE} go high, the device will stay in the read mode and treat \overline{CE} go low of the first clock as address instead of command cycle.

To exit enhance mode, a new fast read command whose first two dummy cycles is not toggle then exit. Or issue "FFh" command to exit enhance mode.

(12) Mode Bit Reset (FFh)

To conduct the Performance Enhance Mode Reset operation in SPI mode, FFh command code, 8 clocks, should be issued in Signal I/O sequence. In QPI mode, FFFFFFFFh command code, 8 clocks, in 4 I/O should be issue (Please refer to Figure 24)

If the system controller is being Reset during operation, the flash device will return to the standard SPI operation.

Upon Reset of main chip, SPI instruction would be issued from the system. Instructions like Read ID (9Fh) or Fast Read (0Bh) would be issued.

(13) Sector Erase (SE)

The Sector Erase (SE) instruction is for erasing the data of the chosen sector to be "1". The instruction is used for any 4K-byte sector. A Write Enable (WREN) instruction must execute to set the Write Enable Latch (WEL) bit before sending the Sector Erase (SE). Any address of the sector (see table of memory organization) is a valid address for Sector Erase (SE) instruction. The \overline{CE} must go high exactly at the byte boundary (the latest eighth of address byte been latched-in); otherwise, the instruction will be rejected and not executed.

Address bits [$A_{MS}-A_{12}$] (A_{MS} is the most significant address) select the sector address.

The sequence of issuing SE instruction is: \overline{CE} goes low → sending SE instruction code → 3-byte address on SI → \overline{CE} goes high. (Please refer to Figure 15-1 and Figure 15-2)

If \overline{RESET} goes low while Sector Erase (SE) execution is on going, the operation of SE will finish after T_{SE} timing before entering Reset mode.

The self-timed Sector Erase Cycle time (T_{SE}) is initiated as soon as \overline{CE} goes high. The BUSY bit still can be check out during the Sector Erase cycle is in progress. The BUSY sets 1 during the T_{SE} timing, and sets 0 when Sector Erase Cycle is completed, and the Write Enable Latch (WEL) bit is reset. If the sector is protected by BP3, BP2, BP1, BP0 bits, the Sector Erase (SE) instruction will not be executed on the sector.

(14) 32K Byte Block Erase (BE32K)

The 32K Byte Block Erase (BE32K) instruction is for erasing the data of the chosen block to be "1". The instruction is used for 32K-byte block erase operation. A Write Enable (WREN) instruction must execute to set the Write Enable Latch (WEL) bit before sending the Block Erase (BE32K). Any address of the block (see table of memory organization) is a valid address for Block Erase (BE32K) instruction. The \overline{CE} must go high exactly at the byte boundary (the latest eighth of address byte been latched-in); otherwise, the instruction will be rejected and not executed.

The sequence of issuing BE32K instruction is: \overline{CE} goes low → sending BE32K instruction code → 3-byte address on SI → \overline{CE} goes high. (Please refer to Figure 16-1 and Figure 16-2)

If \overline{RESET} goes low while Block Erase (BE32K) execution is on going, the operation of BE32K will finish after T_{BE1} timing before entering Reset mode.

The self-timed Block Erase Cycle time (T_{BE1}) is initiated as soon as Chip Enable (\overline{CE}) goes high. The BUSY bit still can be check out during the Block Erase cycle is in progress. The BUSY sets 1 during the T_{BE1} timing, and sets 0 when Block Erase Cycle is completed, and the Write Enable Latch (WEL) bit is reset. If the block is protected by BP3, BP2, BP1, BP0 bits, the Block Erase (BE32K) instruction will not be executed on the block.

(15) 64K Byte Block Erase (BE)

The 64K Byte Block Erase (BE) instruction is for erasing the data of the chosen block to be "1". The instruction is used for 64K-byte block erase operation. A Write Enable (WREN) instruction must execute to set the Write Enable Latch (WEL) bit before sending the Block Erase (BE). Any address of the block (Please refer to table of memory organization) is a valid address for Block Erase (BE) instruction. The \overline{CE} must go high exactly at the byte boundary (the latest eighth of address byte been latched-in); otherwise, the instruction will be rejected and not executed.

The sequence of issuing BE instruction is: \overline{CE} goes low → sending BE instruction code → 3-byte address on SI → \overline{CE} goes high. (Please refer to Figure 17-1 and Figure 17-2)

The self-timed Block Erase Cycle time (T_{BE2}) is initiated as soon as \overline{CE} goes high. The BUSY bit still can be check out during the Block Erase cycle is in progress. The BUSY sets 1 during the T_{BE2} timing, and sets 0 when Block Erase Cycle is completed, and the Write Enable Latch (WEL) bit is reset. If the block is protected by BP3, BP2, BP1, BP0 bits, the Block Erase (BE) instruction will not be executed on the block.

(16) Chip Erase (CE)

The Chip Erase (CE) instruction is for erasing the data of the whole chip to be "1". A Write Enable (WREN) instruction must execute to set the Write Enable Latch (WEL) bit before sending the Chip Erase (CE). The \overline{CE} must go high exactly at the byte boundary, otherwise the instruction will be rejected and not executed.

The sequence of issuing CE instruction is: \overline{CE} goes low → sending CE instruction code → \overline{CE} goes high. (Please refer to Figure 18-1 and Figure 18-2)

The self-timed Chip Erase Cycle time (T_{CE}) is initiated as soon as \overline{CE} goes high. The BUSY bit still can be check out during the Chip Erase cycle is in progress. The BUSY sets 1 during the T_{CE} timing, and sets 0 when Chip Erase Cycle is completed, and the Write Enable Latch (WEL) bit is reset. If the chip is protected by BP3, BP2, BP1, BP0 bits, the Chip Erase (CE) instruction will not be executed. It will be only executed when BP3, BP2, BP1, BP0 all set to "0".

(17) Page Program (PP)

The Page Program (PP) instruction is for programming the memory to be "0". A Write Enable (WREN) instruction must execute to set the Write Enable Latch (WEL) bit before sending the Page Program (PP). The device programs only the last 256 data bytes sent to the device. If the entire 256 data bytes are going to be programmed, A₇-A₀ (The eight least significant address bits) should be set to 0. If the eight least significant address bits (A₇-A₀) are not all 0, all transmitted data going beyond the end of the current page are programmed from the start address of the same page (from the address A₇-A₀ are all 0). If more than 256 bytes are sent to the device, the data of the last 256-byte is programmed at the request page and previous data will be disregarded. If less than 256 bytes are sent to the device, the data is programmed at the requested address of the page without effect on other address of the same page.

The sequence of issuing PP instruction is: \overline{CE} goes low → sending PP instruction code → 3-byte address on SI → at least 1-byte on data on SI → \overline{CE} goes high. (Please refer to Figure 13-1 and Figure 13-2)

The \overline{CE} must be kept to low during the whole Page Program cycle; The \overline{CE} must go high exactly at the byte boundary (the latest eighth bit of data being latched in), otherwise the instruction will be rejected and will not be executed.

The self-timed Page Program Cycle time (T_{PP}) is initiated as soon as \overline{CE} goes high. The BUSY bit still can be check out during the Page Program cycle is in progress. The BUSY sets 1 during the T_{PP} timing, and sets 0 when Page Program Cycle is completed, and the Write Enable Latch (WEL) bit is reset. If the page is protected by BP3, BP2, BP1, BP0 bits, the Page Program (PP) instruction will not be executed.

(18) Quad Page Program (4PP)

The Quad Page Program (4PP) instruction is for programming the memory to be "0". A Write Enable (WREN) instruction must execute to set the Write Enable Latch (WEL) bit and Quad Enable (QE) bit must be set to "1" before sending the Quad Page Program (4PP). The Quad Page Programming takes four pins: SIO₀, SIO₁, SIO₂, and SIO₃ as address and data input, which can improve programmer performance and the effectiveness of application of lower clock less than 33MHz. For system with faster clock, the Quad page program cannot provide more actual favors, because the required internal page program time is far more than the time data flows in. Therefore, we suggest that while executing this command (especially during sending data), user can slow the clock speed down to 33MHz below. The other function descriptions are as same as standard page program.

The sequence of issuing 4PP instruction is: \overline{CE} goes low → sending 4PP instruction code → 3-byte address on SIO[3:0] → at least 1-byte on data on SIO[3:0] → \overline{CE} goes high.

(19) Deep Power-down (DP)

The Deep Power-down (DP) instruction is for setting the device on the minimizing the power consumption (to entering the Deep Power-down mode), the standby current is reduced from I_{SB1} to I_{SB2}). The Deep Power-down mode requires the Deep Power-down (DP) instruction to enter, during the Deep Power-down mode, the device is not active and all Write/Program/Erase instruction are ignored. When \overline{CE} goes high, it's only in deep power-down mode not standby mode. It's different from Standby mode.

The sequence of issuing DP instruction is: \overline{CE} goes low → sending DP instruction code → \overline{CE} goes high. (Please refer to Figure 19-1 and Figure 19-2)

Once the DP instruction is set, all instruction will be ignored except the Release from Deep Power-down mode (RDP) and Read Electronic Signature (RES) instruction and software reset command. (those instructions allow the ID being reading out). When Power-down, or software reset command the deep power-down mode automatically stops, and when power-up, the device automatically is in standby mode. For DP instruction, the \overline{CE} must go high exactly at the byte boundary (the latest eighth bit of instruction code been latched-in); otherwise, the instruction will not executed. As soon as \overline{CE} goes high, a delay of T_{DP} is required before entering the Deep Power-down mode.

(20) Release from Deep Power-down (RDP), Read Electronic Signature (RES)

The Release from Deep Power-down (RDP) instruction is terminated by driving \overline{CE} High. When \overline{CE} is driven High, the device is put in the Stand-by Power mode. If the device was not previously in the Deep Power-down mode, the transition to the Stand-by Power mode is immediate. If the device was previously in the Deep Power-down mode, though, the transition to the Stand-by Power mode is delayed by T_{RES2} , and \overline{CE} must remain High for at least T_{RES2} (max), as specified in Table 20. AC Characteristics. Once in the Stand-by Power mode, the device waits to be selected, so that it can receive, decode and execute instructions. The RDP instruction is for releasing from Deep Power Down Mode. \overline{RESET} pin goes low will also release the Flash from deep power down mode.

RES instruction is for reading out the old style of 8-bit Electronic Signature, whose values are shown as table of ID Definitions. This is not the same as RDID instruction. It is not recommended to use for new design. For new design, please use RDID instruction.

The sequence is shown as Figure 20-1, Figure 20-2, Figure 21-1 and Figure 21-2. Even in Deep power-down mode, the RDP and RES are also allowed to be executed, only except the device is in progress of program/erase/write cycle; there's no effect on the current program/erase/write cycle in progress.

The RES instruction is ended by \overline{CE} goes high after the ID has been read out at least once. The ID outputs repeatedly if continuously send the additional clock cycles on SCK while \overline{CE} is at low. If the device was not previously in Deep Power-down mode, the device transition to standby mode is immediate. If the device was previously in Deep Power-down mode, there's a delay of T_{RES2} to transit to standby mode, and \overline{CE} must remain high at least T_{RES2} (max). Once in the standby mode, the device waits to be selected, so it can be receive, decode, and execute instruction.

(21) Read Electronic Manufacturer ID & Device ID (REMS)

The REMS instruction is an alternative to the Release from Power-down/Device ID instruction that provides both the JEDEC assigned manufacturer ID and the specific device ID.

The REMS instruction is very similar to the Release from Power-down/Device ID instruction. The instruction is initiated by driving the \overline{CE} pin low and shift the instruction code "90h" followed by two dummy bytes and one bytes address ($A_7 \sim A_0$). After which, the Manufacturer ID for ESMT (8Ch) and the Device ID are shifted out on the falling edge of SCK with most significant bit (MSB) first as shown in Figure 22. The Device ID values are listed in Table 10 of ID Definitions. If the one-byte address is initially set to 01h, then the device ID will be read first and then followed by the Manufacturer ID. The Manufacturer and Device IDs can be read continuously, alternating from one to the other. The instruction is completed by driving \overline{CE} high.

(22) QPI ID Read (QPIID)

The QPIID Read instruction identifies the devices as F25D128QA and manufacturer as ESMT. The sequence of issue QPIID instruction is \overline{CE} goes low → sending QPI ID instruction → Data out on SO → \overline{CE} goes high. Most significant bit (MSB) first.

Immediately following the command cycle the device outputs data on the falling edge of the SCK signal. The data output stream is continuous until terminated by a low-to-high transition of \overline{CE} . The device outputs three bytes of data: manufacturer, device type, and device ID.

Table 10. ID Definitions

Command Type	F25D128QA		
	RDID (JEDEC ID)	manufacturer ID	memory type
	8C	25	38
RES	electronic ID	in secured OTP mode & non lock down	in secured OTP mode & lock down
	38	78	F8
REMS	manufacturer ID	device ID	
	8C	38	

(23) Enter Secured OTP (ENSO)

The ENSO instruction is for entering the additional 512 bytes secured OTP mode. The additional 512 bytes secured OTP is independent from main array, which may use to store unique serial number for system identifier. After entering the Secured OTP mode, and then follow standard read or program, procedure to read out the data or update data. The Secured OTP data cannot be updated again once it is lock-down.

The sequence of issuing ENSO instruction is: \overline{CE} goes low → sending ENSO instruction to enter Secured OTP mode → \overline{CE} goes high.

Please note that WRSR/WRSCUR commands are not acceptable during the access of secure OTP region, once security OTP is lock down, only read related commands are valid.

(24) Exit Secured OTP (EXSO)

The EXSO instruction is for exiting the additional 512 bytes secured OTP mode.

The sequence of issuing EXSO instruction is: \overline{CE} goes low→ sending EXSO instruction to exit Secured OTP mode→ \overline{CE} goes high.

(25) Read Security Register (RDSCUR)

The RDSCUR instruction is for reading the value of Security Register bits. The Read Security Register can be read at any time (even in program/erase/write status register/write security register condition) and continuously.

The sequence of issuing RDSCUR instruction is: \overline{CE} goes low → sending RDSCUR instruction → Security Register data out on SO→ \overline{CE} goes high.

The definition of the Security Register bits is as below:

Secured OTP Indicator bit. The Secured OTP indicator bit shows the chip is locked by factory before ex- factory or not. When it is "0", it indicates non-factory lock; "1" indicates factory-lock.

Lock-down Secured OTP (LDSO) bit. By writing WRSCUR instruction, the LDSO bit may be set to "1" for customer lock-down purpose. However, once the bit is set to "1" (lock-down), the LDSO bit and the 512 bytes Secured OTP area cannot be update any more. While it is in 512 bytes secured OTP mode, main array access is not allowed.

Table 11. Security Register Definition

bit7	bit6	bit5	bit4	bit3	bit2	bit1	bit0
WPSEL	E_FAIL	P_FAIL	Reserved	Erase Suspend bit	Program Suspend bit	LDSO (indicate if lock-down)	Secured OTP indicator bit
0 = normal WP mode 1 = individual mode (default = 0)	0 = normal Erase succeed 1 = individual Erase failed (default = 0)	0 = normal Program succeed 1= indicate Program failed (default = 0)	-	0 = Erase is not suspended 1= Erase suspended (default = 0)	0 = Program is not suspended 1= Program suspended (default = 0)	0 = not lock-down 1 = lock-down (cannot program/erase OTP)	0 = non-factory lock 1 = factory lock
Non-volatile bit (OTP)	Volatile bit	Volatile bit	Volatile bit	Volatile bit	Volatile bit	Non-volatile bit (OTP)	Non-volatile bit (OTP)

(26) Write Security Register (WRSCUR)

The WRSCUR instruction is for setting the values of Security Register Bits. The WREN (Write Enable) instruction is required before issuing WRSCUR instruction. The WRSCUR instruction may change the values of bit1 (LDSO bit) for customer to lock-down the 512 bytes Secured OTP area. Once the LDSO bit is set to "1", the Secured OTP area cannot be updated any more. The LDSO bit is an OTP bit. Once the LDSO bit is set, the value of LDSO bit can not be altered any more.

The sequence of issuing WRSCUR instruction is: \overline{CE} goes low → sending WRSCUR instruction → \overline{CE} goes high.

The \overline{CE} must go high exactly at the boundary; otherwise, the instruction will be rejected and not executed.

(27) Write Protection Selection (WPSEL)

When the system accepts and executes WPSEL instruction, the bit 7 in security register will be set. The WREN (Write Enable) instruction is required before issuing WPSEL instruction. It will activate SBLK, SBULK, RDBLOCK, GBLK, GBULK etc instructions to conduct block lock protection and replace the original Software Protect Mode (SPM) use (BP3~BP0) indicated block methods.

The sequence of issuing WPSEL instruction is: \overline{CE} goes low → sending WPSEL instruction to enter the individual block protect mode → \overline{CE} goes high.

Every time after the system is powered-on, and the Security Register bit 7 is checked to be WPSEL=1, all the blocks or sectors will be write protected by default. User may only unlock the blocks or sectors via SBULK and GBULK instruction. Program or erase functions can only be operated after the Unlock instruction is conducted.

Once WPSEL is set, it cannot be changed.

WPSEL instruction function flow is as follows:

WPSEL Flow

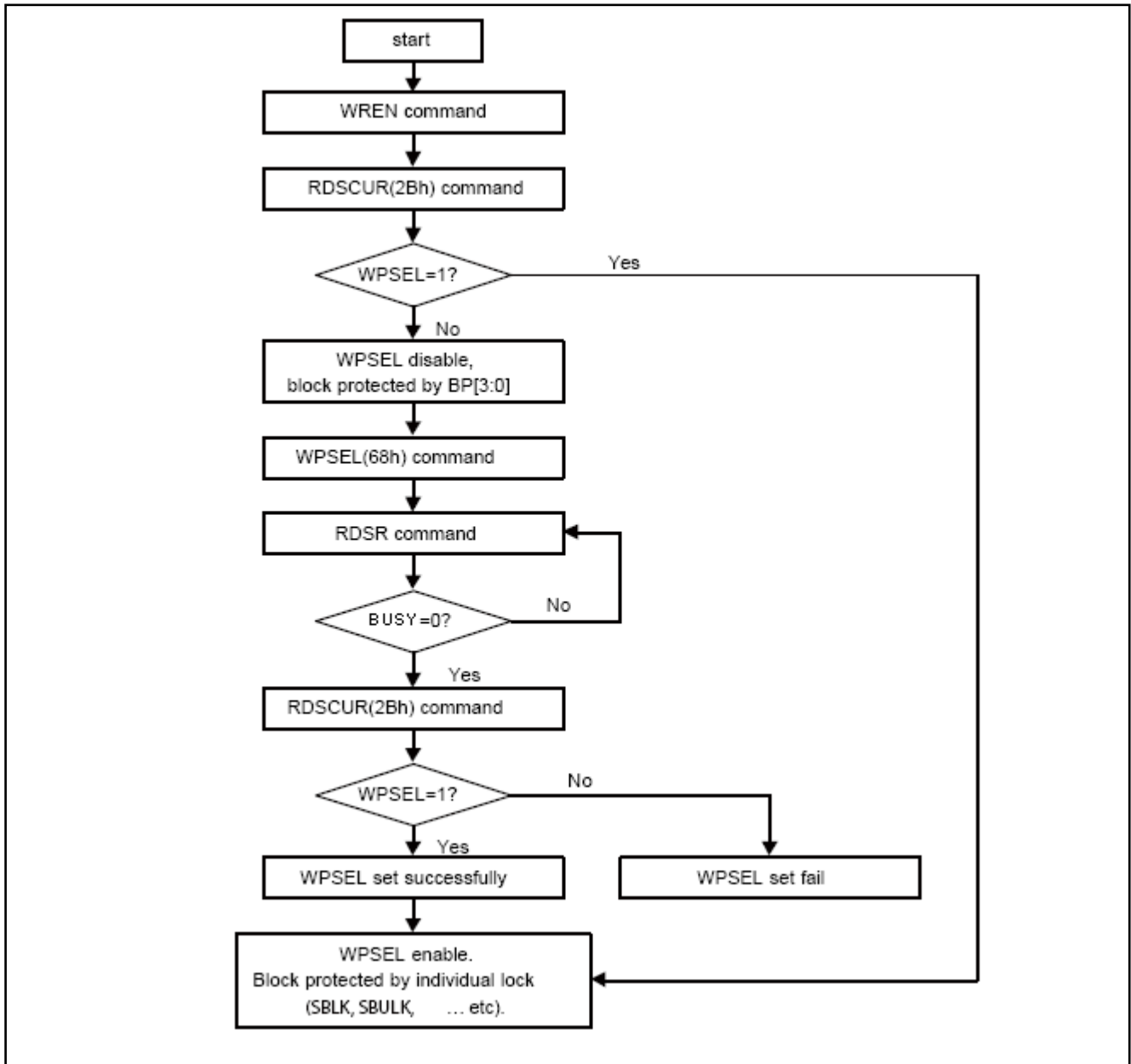

(28) Single Block Lock/Unlock Protection (SBLK/SBULK)

These instructions are only effective after WPSEL was executed. The SBLK instruction is for write protection a specified block (or sector) of memory, using A_{MS-A16} or (A_{MS-A12}) address bits to assign a 64Kbyte block (or 4K bytes sector) to be protected as read only. The SBULK instruction will cancel the block (or sector) write protection state. This feature allows user to stop protecting the entire block (or sector) through the chip unprotect command (GBULK).

The WREN (Write Enable) instruction is required before issuing SBLK/SBULK instruction.

The sequence of issuing SBLK/SBULK instruction is: \overline{CE} goes low → send SBLK/SBULK (36h/39h) instruction → send 3 address bytes assign one block (or sector) to be protected on SI pin → \overline{CE} goes high. The \overline{CE} must go high exactly at the byte boundary, otherwise the instruction will be rejected and not be executed.

SBLK/SBULK instruction function flow is as follows:

Block Lock Flow

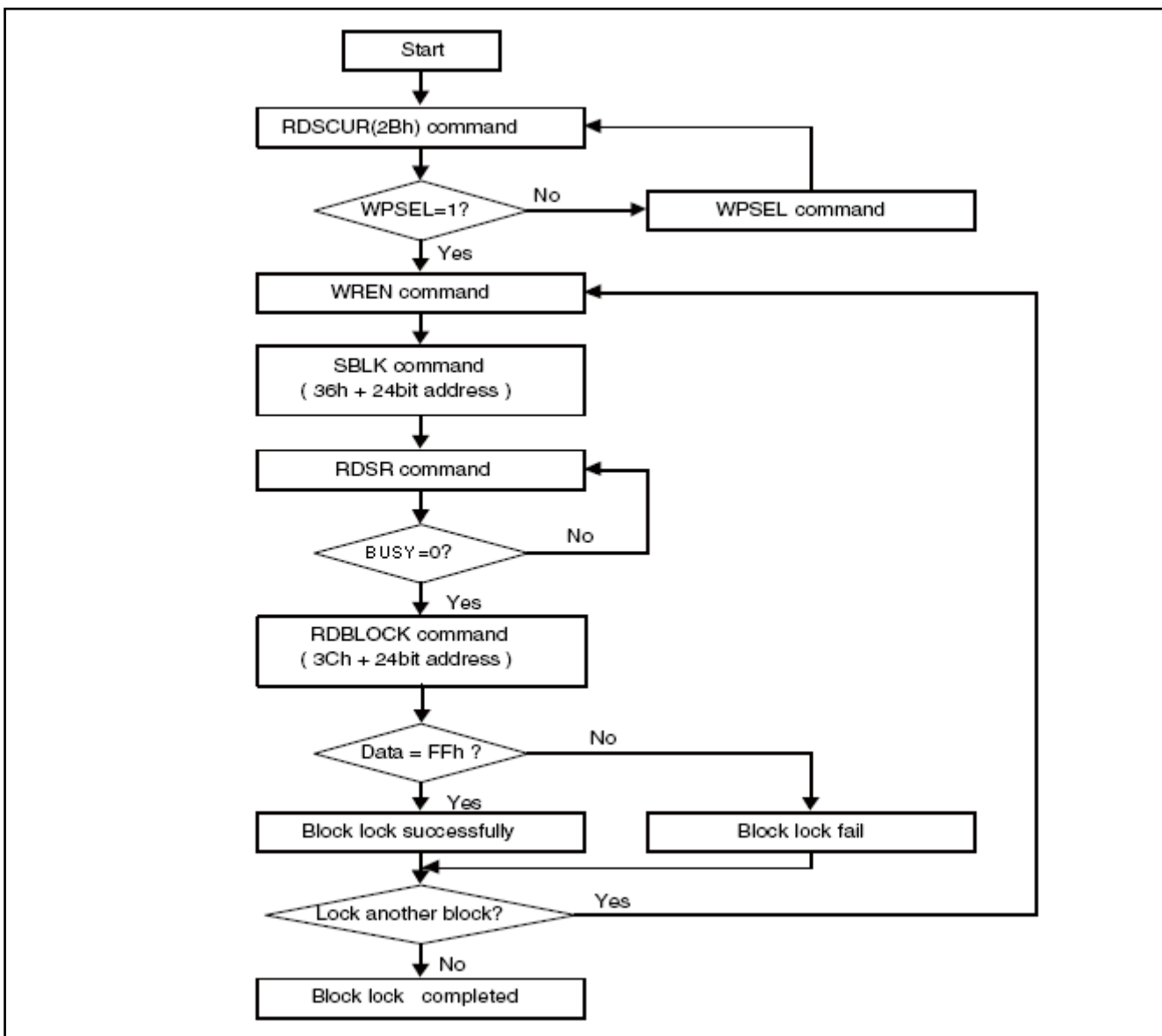

Block Unlock Flow

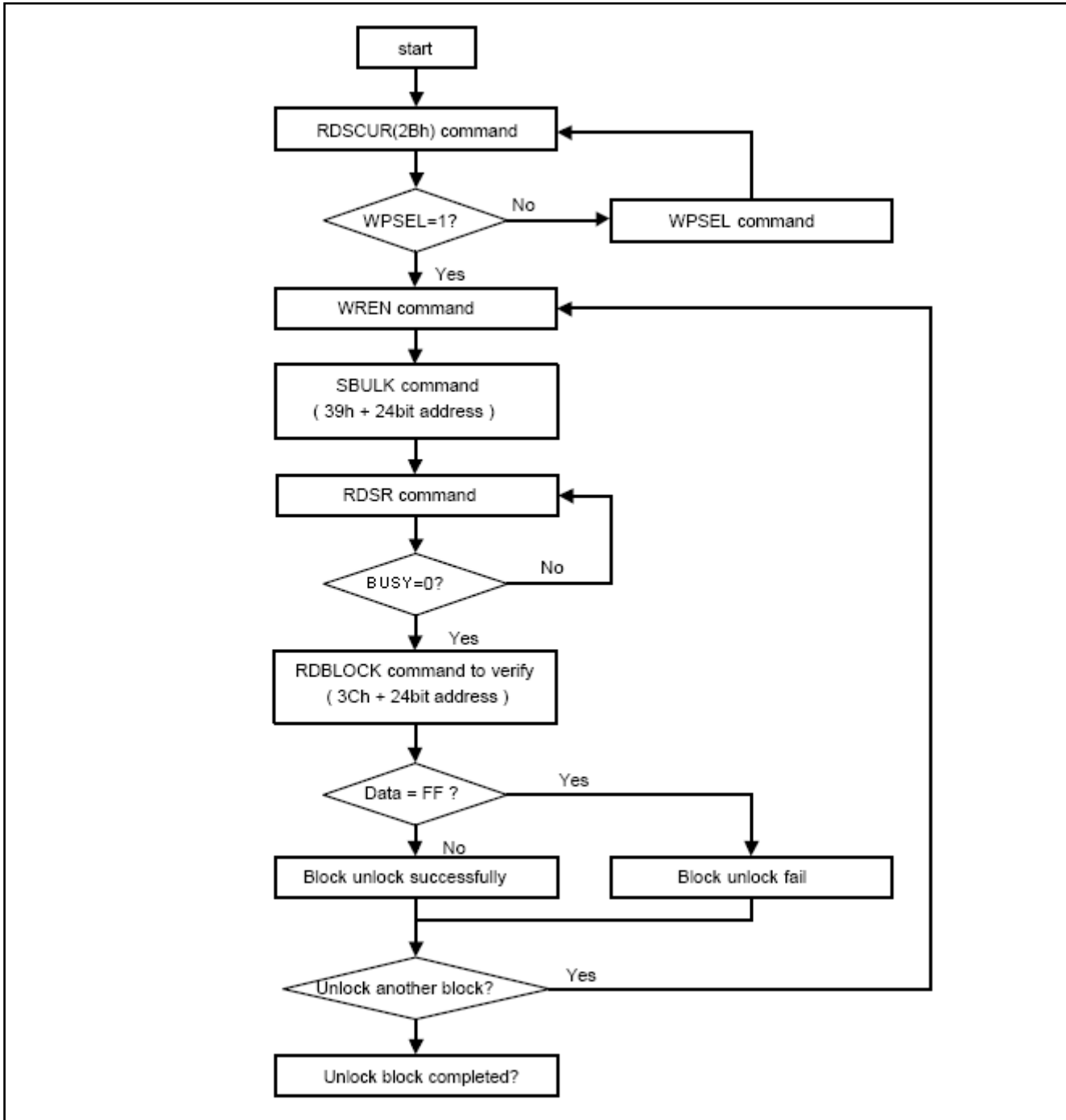

(29) Read Block Lock Status (RDBLOCK)

This instruction is only effective after WPSEL was executed. The RDBLOCK instruction is for reading the status of protection lock of a specified block (or sector), using $A_{MS-A_{16}}$ (or $A_{MS-A_{12}}$) address bits to assign a 64K bytes block (4K bytes sector) and read protection lock status bit which the first byte of Read-out cycle. The status bit is "1" to indicate that this block has been protected, that user can read only but cannot write/program /erase this block. The status bit is "0" to indicate that this block hasn't be protected, and user can read and write this block.

The sequence of issuing RDBLOCK instruction is: \overline{CE} goes low → send RDBLOCK (3Ch) instruction → send 3 address bytes to assign one block on SI pin → read block's protection lock status bit on SO pin → \overline{CE} goes high.

(30) Gang Block Lock/Unlock (GBLK/GBULK)

These instructions are only effective after WPSEL was executed. The GBLK/GBULK instruction is for enable/disable the lock protection block of the whole chip.

The WREN (Write Enable) instruction is required before issuing GBLK/GBULK instruction.

The sequence of issuing GBLK/GBULK instruction is: \overline{CE} goes low → send GBLK/GBULK (7Eh/98h) instruction → \overline{CE} goes high.

The \overline{CE} must go high exactly at the byte boundary, otherwise, the instruction will be rejected and not be executed.

(31) Program/ Erase Suspend/ Resume

The device allows the interruption of Sector-Erase, Block-Erase or Page-Program operations and conduct other operations. Details as follows.

To enter the suspend / resume mode: issuing B0h for suspend; 30h for resume (SPI/QPI all acceptable).
Read security register bit2 (PSB) and bit3 (ESB) (please refer to Table 11) to check suspend ready information.
Suspend to suspend ready timing: 20us.
Resume to another suspend timing: 1ms.

ESB bit (Erase Suspend Bit) indicates the status of Erase suspend operation. When issue a suspend command during erase operation ESB=1, when erase operation resumes, ESB will be reset to "0".

(31-1) Erase Suspend

Erase suspend allow the interruption of all erase operations.

After erase suspend, WEL bit will be clear, only read related, resume and reset command can be accepted. (including: 03h, 0Bh, BBh, EBh, E7h, 9Fh, 90h, 05h, 2Bh, B1h, C1h, 3Ch, 30h, 66h, 99h, C0h, 00h, ABh)

After issue erase suspend command, latency time 20us is needed before issue another command. For "Suspend to Read", "Resume to Read", "Resume to Suspend" timing specification please note Figure 27-1, Figure 27-2 and Figure 27-3.

ESB bit (Erase Suspend Bit) indicates the status of Erase suspend operation. When issue a suspend command during program operation ESB=1, when erase operation resumes, ESB will be reset to "0".

When ESB bit is issued, the Write Enable Latch (WEL) bit will be reset. See Figure 27-1 for Suspend to Read latency.

(31-2) Program Suspend

Program suspend allows the interruption of all program operations.

After program suspend, WEL bit will be cleared, only read related, resume and reset command can be accepted. (including: 03h, 0Bh, BBh, EBh, E7h, 9Fh, 90h, 05h, 2Bh, B1h, C1h, 3Ch, 30h, 66h, 99h, C0h, 00h, ABh)

After issue program suspend command, latency time 20us is needed before issue another command.

For "Suspend to Read", "Resume to Read", "Resume to Suspend" timing specification please note Figure 27-1, Figure 27-2 and Figure 27-3.

PSB bit (Program Suspend Bit) indicates the status of Program suspend operation. When issue a suspend command during program operation PSB=1, when program operation resumes, PSB will be reset to "0".

(32) Write-Resume

The Write operation is being resumed when Write-Resume instruction issued. ESB or PSB (suspend status bit) in Status register will be changed back to "0"

The operation of Write-Resume is as follows: \overline{CE} drives low → send write resume command cycle (30h) → drive \overline{CE} high. By polling Busy Bit in status register, the internal write operation status could be checked to be completed or not. The user may also wait the time lag of T_{SE} , T_{BE} , T_{PP} for Sector-erase, Block-erase or Page-programming. WREN (command "06" is not required to issue before resume. Resume to another suspend operation requires latency time of 1ms.

When Erase Suspend is being resumed, the WEL bit need to be set again if user desire to conduct the program or erase operation.

Please note that, if "performance enhance mode" is executed during suspend operation, the device can not be resume. To restart the write command, disable the "performance enhance mode" is required. After the "performance enhance mode" is disable, the write-resume command is effective.

(33) No Operation (NOP)

The No Operation command only cancels a Reset Enable command. NOP has no impact on any other command.

(34) Software Reset (Reset-Enable (RSTEN) and Reset (RST))

The Reset operation is used as a system (software) reset that puts the device in normal operating Ready mode. This operation consists of two commands: Reset-Enable (RSTEN) and Reset (RST).

To reset the F25D128QA the host drives \overline{CE} low, sends the Reset-Enable command (66h), and drives \overline{CE} high. Next, the host drives \overline{CE} low again, sends the Reset command (99h), and drives \overline{CE} high.

The Reset operation requires the Reset-Enable command followed by the Reset command. Any command other than the Reset command after the Reset-Enable command will disable the Reset-Enable.

A successful command execution will reset the device to SPI stand-by read mode, which are their respective default states, see Figure 28. A device reset during an active Program or Erase operation aborts the operation, which can cause the data of the targeted address range to be corrupted or lost. Depending on the prior operation, the reset timing may vary. Recovery from a Write operation requires more latency time than recovery from other operations.

(35) Read SFDP Mode (RDSFDP)

The Serial Flash Discoverable Parameter (SFDP) standard provides a consistent method of describing the functional and feature capabilities of serial flash devices in a standard set of internal parameter tables. These parameter tables can be interrogated by host system software to enable adjustments needed to accommodate divergent features from multiple vendors. The concept is similar to the one found in the Introduction of JEDEC Standard, JESD68 on CFI.

SPI mode

The sequence of issuing RDSFDP instruction is same as FAST_READ: \overline{CE} goes low → send RDSFDP instruction (5Ah) → send 3-byte address on SI pin → send 1 dummy byte on SI pin → read SFDP code on SO → to end RDSFDP operation can use \overline{CE} to high at any time during data out. (Please refer to Figure 29-1)

QPI mode

The sequence of issuing RDSFDP instruction is same as FAST_READ: \overline{CE} goes low → sending Fast Read instruction code, 2 cycle → 24-bit address on SIO₃~SIO₀ → 4 dummy cycle → data out interleave on SIO₃~SIO₀ → to end QPI RDSFDP operation can use \overline{CE} to high at any time during data out. (Please refer to Figure 29-2)

SFDP is a standard of JEDEC. JESD216. v1.0.

(36) Read Unique ID Number

The Read Unique ID Number instruction accesses a factory-set read-only 64-bit number that is unique to each device. The ID number can be used in conjunction with user software methods to help prevent copying or cloning of a system.

The sequence of issuing Read Unique ID Number instruction: \overline{CE} goes low → send Read Unique ID Number instruction (4Bh) → send 4 dummy byte on SI pin → read 64-bit number on SO → to end Read Unique ID Number operation can use \overline{CE} to high at any time during data out. (Please refer to Figure 30)

Table 12: Signature and Parameter Identification Data Values

Description	Comment	Add (Byte)	DW Add (Bit)	Data ¹ (h/b)	Data (h)
SFDP Signature	Fixed: 50444653h	00h	07:00	53h	53h
		01h	15:08	46h	46h
		02h	23:16	44h	44h
		03h	31:24	50h	50h
SFDP Minor Revision Number	Start from 00h	04h	07:00	00h	00h
SFDP Major Revision Number	Start from 01h	05h	15:08	01h	01h
Number of Parameter Headers	Start from 00h	06h	23:16	01h	01h
Unused	Contains 0xFFh and can never be changed	07h	31:24	FFh	FFh
ID number (JEDEC)	00h: it indicates a JEDEC specified header.	08h	07:00	00h	00h
Parameter Table Minor Revision Number	Start from 0x00h	09h	15:08	00h	00h
Parameter Table Major Revision Number	Start from 0x01h	0Ah	23:16	01h	01h
Parameter Table Length (in double word)	How many DWORDs in the Parameter table	0Bh	31:24	09h	09h
Parameter Table Pointer (PTP)	First address of JEDEC Flash Parameter table	0Ch	07:00	30h	30h
		0Dh	15:08	00h	00h
		0Eh	23:16	00h	00h
Unused	Contains 0xFFh and can never be changed	0Fh	31:24	FFh	FFh
ID number (manufacturer ID)	it indicates manufacturer ID	10h	07:00	8Ch	8Ch
Parameter Table Minor Revision Number	Start from 0x00h	11h	15:08	00h	00h
Parameter Table Major Revision Number	Start from 0x01h	12h	23:16	01h	01h
Parameter Table Length (in double word)	How many DWORDs in the Parameter table	13h	31:24	04h	04h
Parameter Table Pointer (PTP)	First address of Flash Parameter table	14h	07:00	60h	60h
		15h	15:08	00h	00h
		16h	23:16	00h	00h
Unused	Contains 0xFFh and can never be changed	17h	31:24	FFh	FFh

Table 13: Parameter Table (0): JEDEC Flash Parameter Table

Description	Comment	Add (Byte)	DW Add (Bit)	Data ¹ (h/b)	Data (h)
Block/Sector Erase sizes	00: Reserved, 01: 4KB erase, 10: Reserved, 11: not support 4KB erase	30h	01:00	01b	E5h
Write Granularity	0: 1Byte, 1: 64Byte or larger		02	1b	
Write Enable Instruction Requested for Writing to Volatile Status Registers	0: Nonvolatile status bit 1: Volatile status bit (BP status register bit)		03	0b	
Write Enable Opcode Select for Writing to Volatile Status Registers	0: use 50h opcode, 1: use 06h opcode Note: If target flash status register is nonvolatile, then bits 3 and 4 must be set to 00b.		04	0b	
Unused	Contains 111b and can never be changed		07:05	111b	
4KB Erase Opcode		31h	15:08	20h	20h
(1-1-2) Fast Read ²	0=not support, 1=support	32h	16	0b	B0h
Address Bytes Number used in addressing flash array	00: 3Byte only, 01: 3 or 4Byte, 10: 4Byte only, 11: Reserved		18:17	00b	
Double Transfer Rate (DTR) Clocking	0=not support, 1=support		19	0b	
(1-2-2) Fast Read	0=not support, 1=support		20	1b	
(1-4-4) Fast Read	0=not support, 1=support		21	1b	
(1-1-4) Fast Read	0=not support, 1=support		22	0b	
Unused			23	1b	
Unused		33h	31:24	FFh	FFh
Flash Memory Density		37h:34h	31:00	07FFFFFFh	
(1-4-4) Fast Read Number of Wait states ³	0 0000b: Wait states (Dummy Clocks) not support	38h	04:00	0 0100b	44h
(1-4-4) Fast Read Number of Mode Bits ⁴	000b: Mode Bits not support		07:05	010b	
(1-4-4) Fast Read Opcode		39h	15:08	EBh	EBh
(1-1-4) Fast Read Number of Wait states	0 0000b: Wait states (Dummy Clocks) not support	3Ah	20:16	0 0000b	00h
(1-1-4) Fast Read Number of Mode Bits	000b: Mode Bits not support		23:21	000b	
(1-1-4) Fast Read Opcode		3Bh	31:24	FFh	FFh

Table 13: Parameter Table (0): JEDEC Flash Parameter Table - Continued

Description	Comment	Add (Byte)	DW Add (Bit)	Data ¹ (h/b)	Data (h)
(1-1-2) Fast Read Number of Wait states	0 0000b: Wait states (Dummy Clocks) not support	3Ch	04:00	0 1000b	48h
(1-1-2) Fast Read Number of Mode Bits	000b: Mode Bits not support		07:05	010b	
(1-1-2) Fast Read Opcode		3Dh	15:08	3Bh	3Bh
(1-2-2) Fast Read Number of Wait states	0 0000b: Wait states(Dummy Clocks) not support	3Eh	20:16	0 0100b	04h
(1-2-2) Fast Read Number of Mode Bits	000b: Mode Bits not support		23:21	000b	
(1-2-2) Fast Read Opcode		3Fh	31:24	BBh	BBh
(2-2-2) Fast Read	0=not support, 1=support	40h	00	0b	FEh
Unused			03:01	111b	
(4-4-4) Fast Read	0=not support, 1=support		04	1b	
Unused			07:05	111b	
Unused		43h:41h	31:08	0xFFh	0xFFh
Unused		45h:44h	15:00	0xFFh	0xFFh
(2-2-2) Fast Read Number of Wait states	0 0000b: Wait states (Dummy Clocks) not support	46h	20:16	0 0000b	00h
(2-2-2) Fast Read Number of Mode Bits	000b: Mode Bits not support		23:21	000b	
(2-2-2) Fast Read Opcode		47h	31:24	FFh	FFh
Unused		49h:48h	15:00	0xFFh	0xFFh
(4-4-4) Fast Read Number of Wait states	0 0000b: Wait states (Dummy Clocks) not support	4Ah	20:16	0 0100b	44h
(4-4-4) Fast Read Number of Mode Bits	000b: Mode Bits not support		23:21	010b	
(4-4-4) Fast Read Opcode		4Bh	31:24	EBh	EBh
Sector Type 1 Size	Sector/block size = 2 ^N bytes ⁵ 0x00b: this sector type don't exist	4Ch	07:00	0Ch	0Ch
Sector Type 1 erase Opcode		4Dh	15:08	20h	20h
Sector Type 2 Size	Sector/block size = 2 ^N bytes 0x00b: this sector type don't exist	4Eh	23:16	0Fh	0Fh
Sector Type 2 erase Opcode		4Fh	31:24	52h	52h
Sector Type 3 Size	Sector/block size = 2 ^N bytes 0x00b: this sector type don't exist	50h	07:00	10h	10h
Sector Type 3 erase Opcode		51h	15:08	D8h	D8h
Sector Type 4 Size	Sector/block size = 2 ^N bytes 0x00b: this sector type don't exist	52h	23:16	00h	00h
Sector Type 4 erase Opcode		53h	31:24	FFh	FFh

Table 14: Parameter Table (1): Flash Parameter Table

Description	Comment	Add (Byte)	DW Add (Bit)	Data ¹ (h/b)	Data (h)
V _{CC} Supply Maximum Voltage	2000h=2.000V 2700h=2.700V 3600h=3.600V	61h:60h	07:00 15:08	00h 20h	00h 20h
V _{CC} Supply Minimum Voltage	1650h=1.650V 2250h=2.250V 2350h=2.350V 2700h=2.700V	63h:62h	23:16 31:24	50h 16h	50h 16h
HW $\overline{\text{RESET}}$ pin	0=not support, 1=support	65h:64h	00	1b	F99Dh
HW $\overline{\text{HOLD}}$ pin	0=not support, 1=support		01	1b	
Deep Power Down Mode	0=not support, 1=support		02	1b	
SW Reset	0=not support, 1=support		03	1b	
SW Reset Opcode	Should be issue Reset Enable (66h) before Reset cmd.		11:04	1001 1001b (99h)	
Program Suspend/Resume	0=not support, 1=support		12	1b	
Erase Suspend/Resume	0=not support, 1=support		13	1b	
Unused			14	1b	
Wrap-Around Read mode	0=not support, 1=support		15	1b	
Wrap-Around Read mode Opcode		66h	23:16	C0h	C0h
Wrap-Around Read data length	08h:support 8B wrap-around read 16h:8B&16B 32h:8B&16B&32B 64h:8B&16B&32B&64B	67h	31:24	64h	64h
Individual block lock	0=not support, 1=support	6Bh:68h	00	1b	C8D9h
Individual block lock bit (Volatile/Nonvolatile)	0=Volatile, 1=Nonvolatile		01	0b	
Individual block lock Opcode			09:02	0011 0110b (36h)	
Individual block lock Volatile protect bit default protect status	0=protect, 1=unprotect		10	0b	
Secured OTP	0=not support, 1=support		11	1b	
Read Lock	0=not support, 1=support		12	0b	
Permanent Lock	0=not support, 1=support		13	0b	
Unused			15:14	11b	
Unused			31:16	FFh	

Notes:

- h/b is hexadecimal or binary.
- (x-y-z)** means I/O mode nomenclature used to indicate the number of active pins used for the opcode (x), address (y), and data (z). At the present time, the only valid Read SFDP instruction modes are: (1-1-1), (2-2-2), and (4-4-4).
- Wait States** is required dummy clock cycles after the address bits or optional mode bits.
- Mode Bits** is optional control bits that follow the address bits. These bits are driven by the system controller if they are specified. (eg, read performance enhance toggling bits)
- 4KB=2⁰Ch,32KB=2⁰Fh,64KB=2¹0h
- Memory within the SFDP address space that has not yet been defined or used, **default to all 0xFFh**.
- The maximum clock rate=33MHz when reading SFDP area.

POWER-ON STATE

The device is at below states when power-up:

- Standby mode (please note it is not deep power-down mode)
- Write Enable Latch (WEL) bit is reset

The device must not be selected during power-up and power-down stage unless the V_{DD} achieves below correct level:

- V_{DD} minimum at power-up stage and then after a delay of T_{VSL}
- GND at power-down

Please note that a pull-up resistor on \overline{CE} may ensure a safe and proper power-up/down level.

An internal power-on reset (POR) circuit may protect the device from data corruption and inadvertent data change during power up state. When V_{DD} is lower than V_{WI} (POR threshold voltage value), the internal logic is reset and the flash device has no response to any command.

For further protection on the device, after V_{DD} reaching the V_{WI} level, a T_{PUW} time delay is required before the device is fully accessible for commands like write enable (WREN), page program (PP), quad page program (4PP), sector erase (SE), block erase 32KB (BE32K), block erase (BE), chip erase (CE), WRSCUR and write status register (WRSR). If the V_{DD} does not reach the V_{DD} minimum level, the correct operation is not guaranteed. The write, erase, and program command should be sent after the below time delay:

- T_{PUW} after V_{DD} reached V_{WI} level
- T_{VSL} after V_{DD} reached V_{DD} minimum level

The device can accept read command after V_{DD} reached V_{DD} minimum and a time delay of T_{VSL} , even time of T_{PUW} has not passed. Please refer to the figure of "power-up timing".

Note:

- To stabilize the V_{DD} level, the V_{DD} rail decoupled by a suitable capacitor close to package pins is recommended. (generally around 0.1uF)
- At power-down stage, the V_{DD} drops below V_{WI} level, all operations are disabled and device has no response to any command.

The data corruption might occur during the stage while a write, program, erase cycle is in progress.

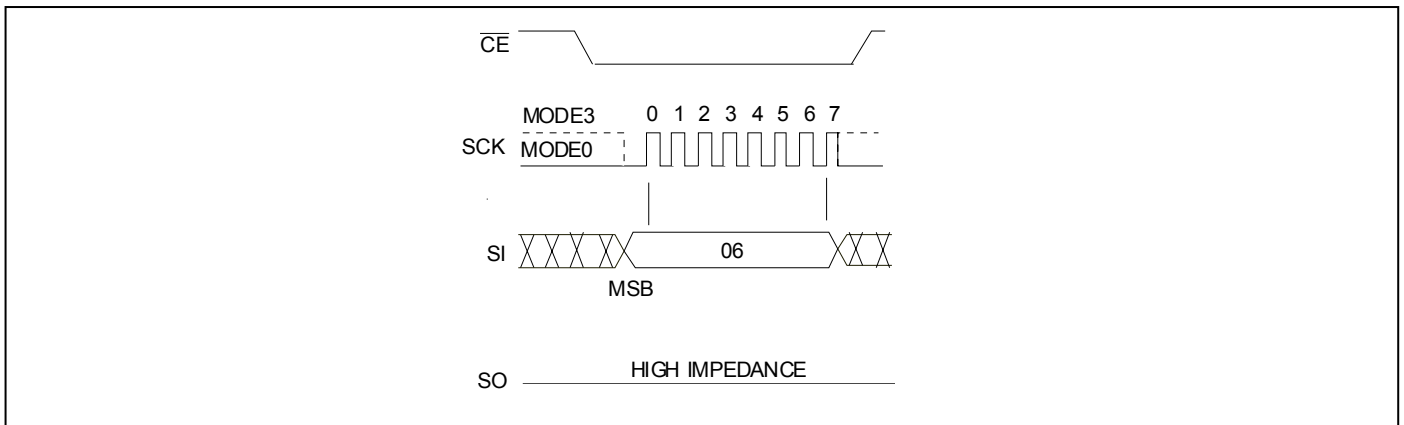

Figure 2-1: Write Enable (WREN) Sequence (SPI Mode)

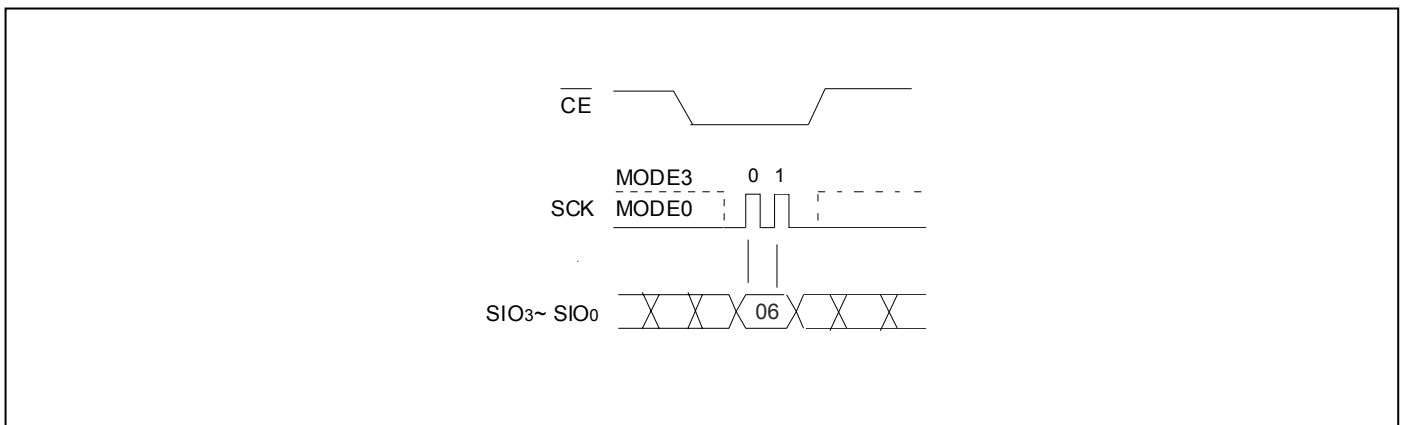

Figure 2-2: Write Enable (WREN) Sequence (QPI Mode)

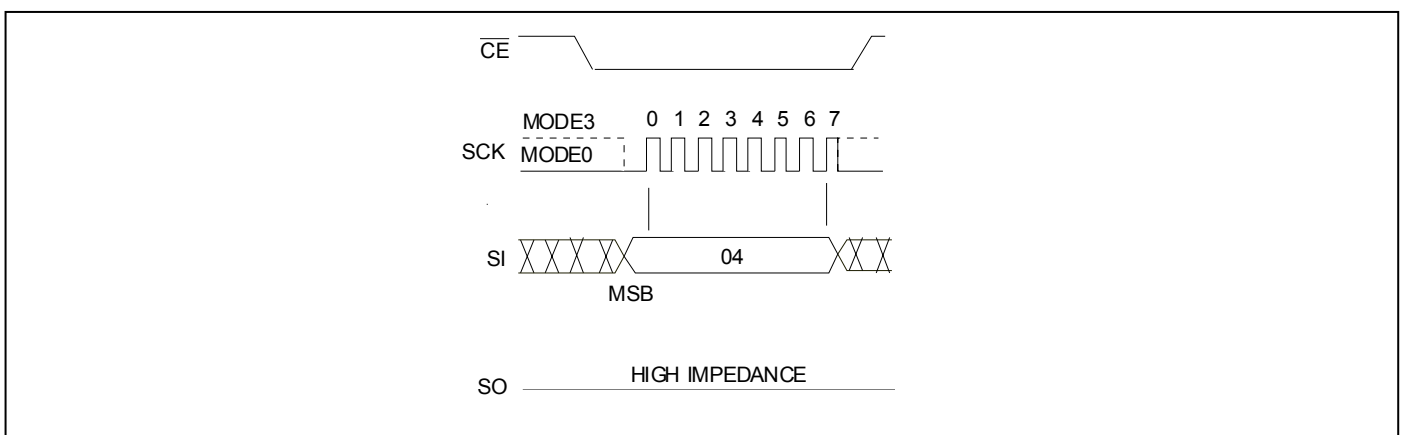

Figure 3-1: Write Disable (WRDI) Sequence (SPI Mode)

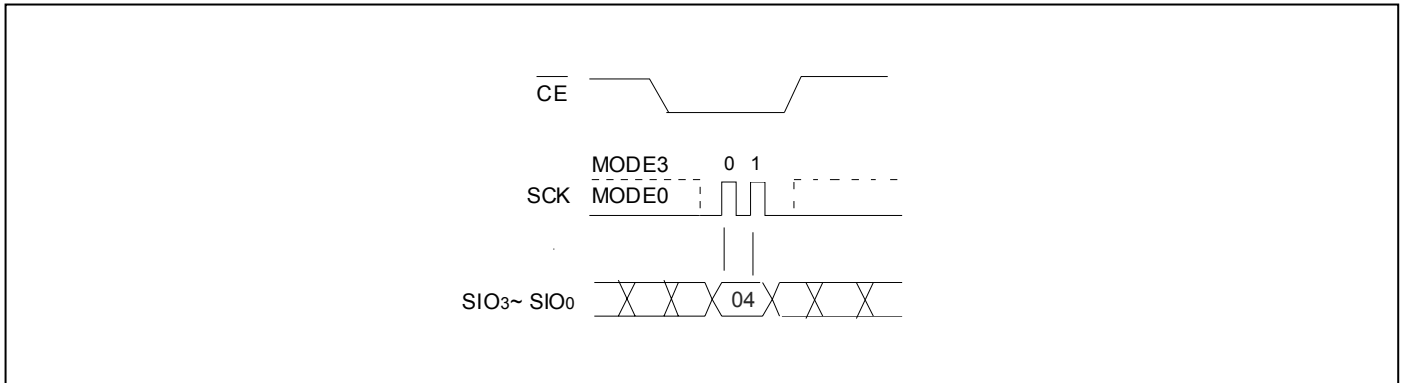

Figure 3-2: Write Disable (WRDI) Sequence (QPI Mode)

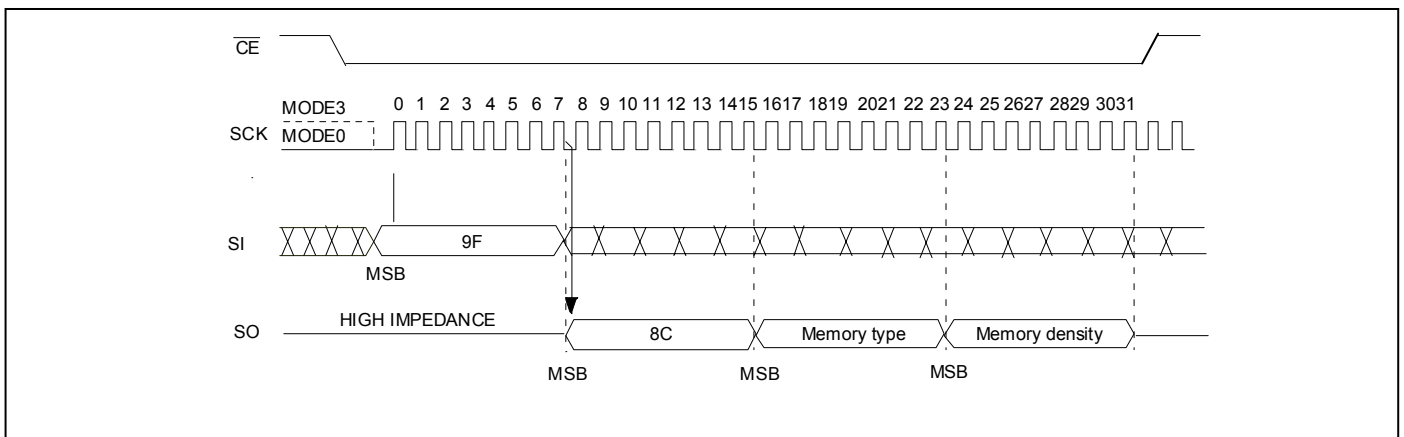

Figure 4: Read Identification (RDID) Sequence (SPI Mode)

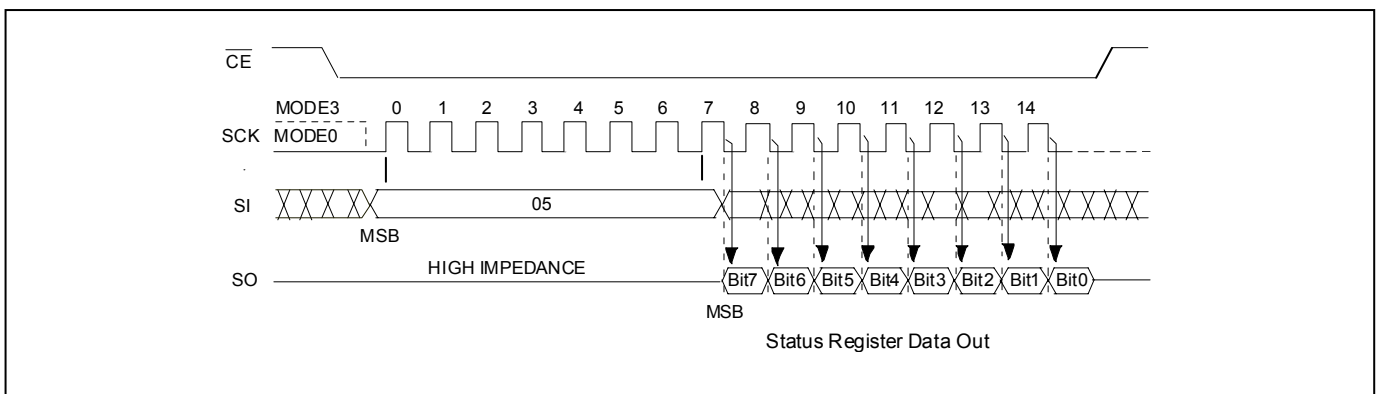

Figure 5-1: Read Status Register (RDSR) Sequence (SPI Mode)

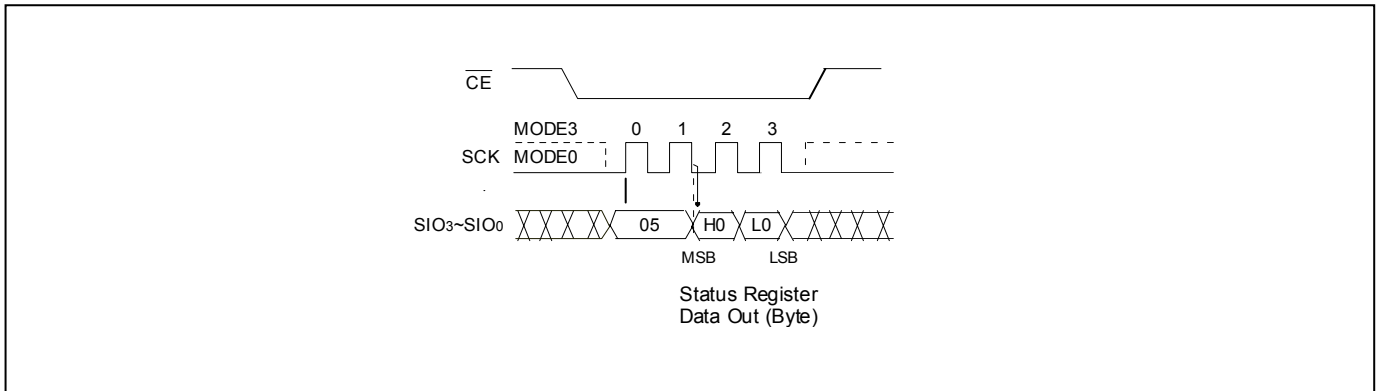

Figure 5-2: Read Status Register (RDSR) Sequence (QPI Mode)

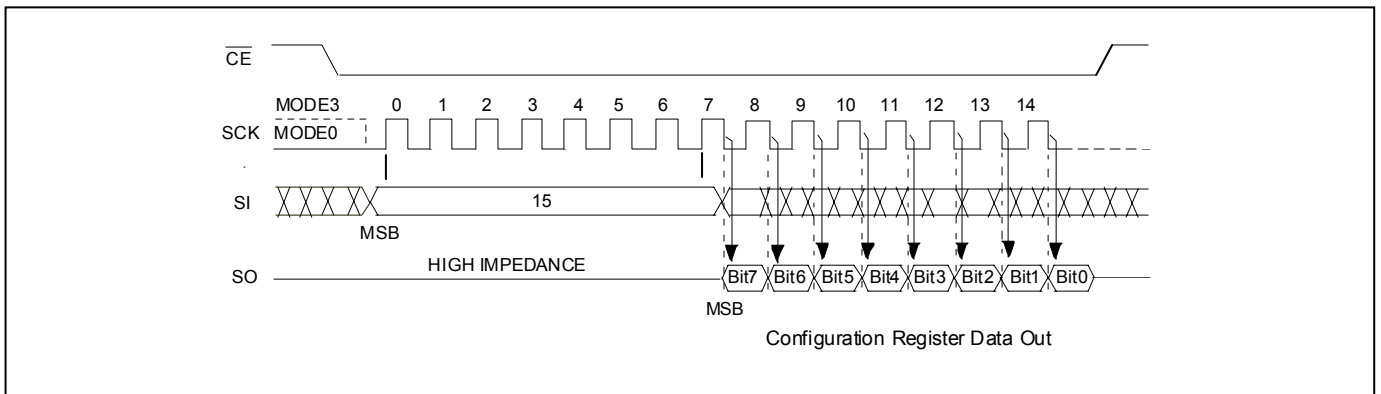

Figure 6-1: Read Configuration Register (RDCR) Sequence (SPI Mode)

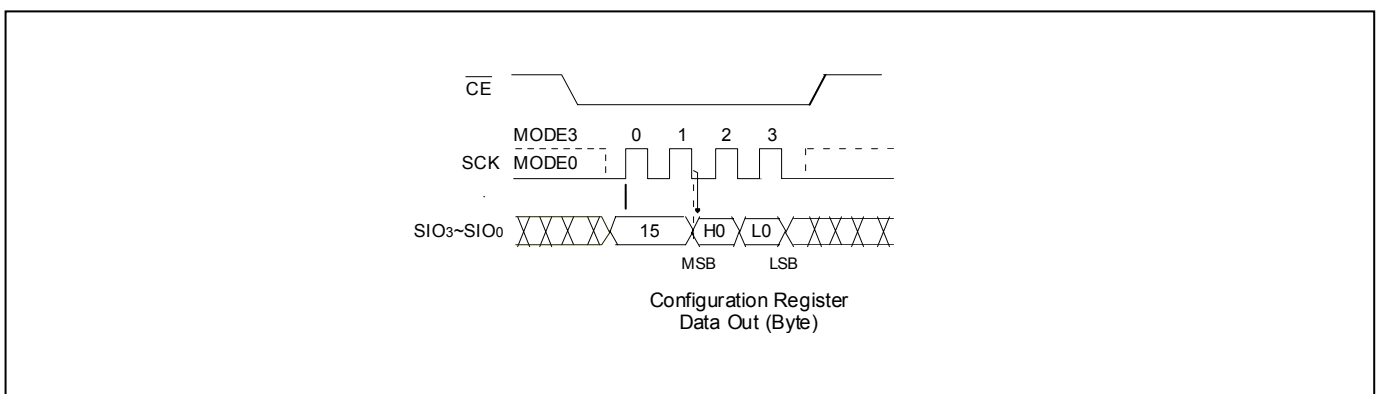

Figure 6-2: Read Configuration Register (RDCR) Sequence (QPI Mode)

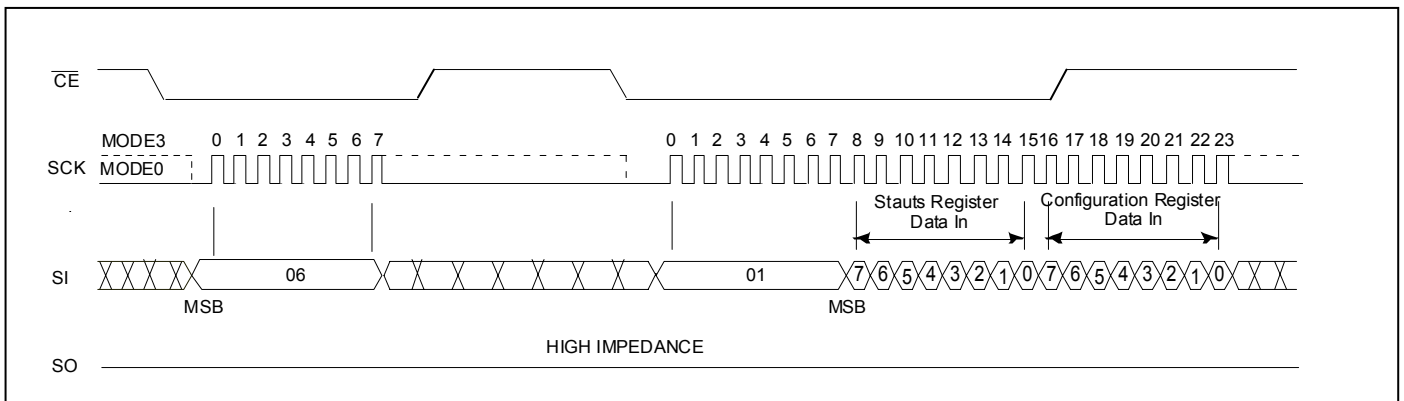

Figure 7-1: Write Enable (WREN) and Write Status Register (WRSR) Sequence (SPI Mode)

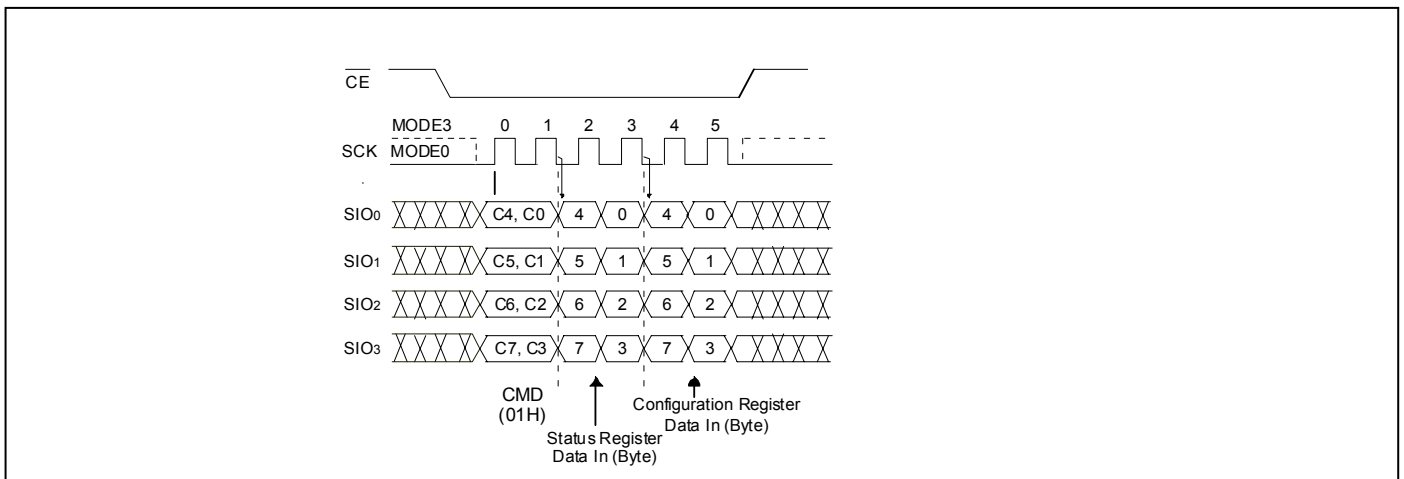

Figure 7-2: Write Status Register (WRSR) Sequence (QPI Mode)

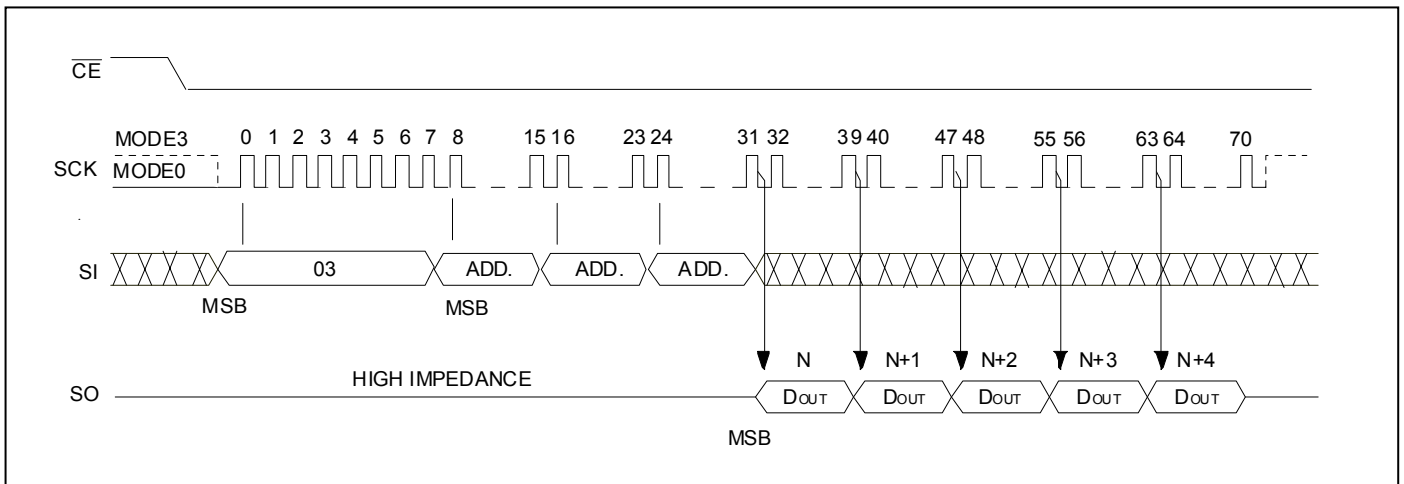

Figure 8: Read Sequence

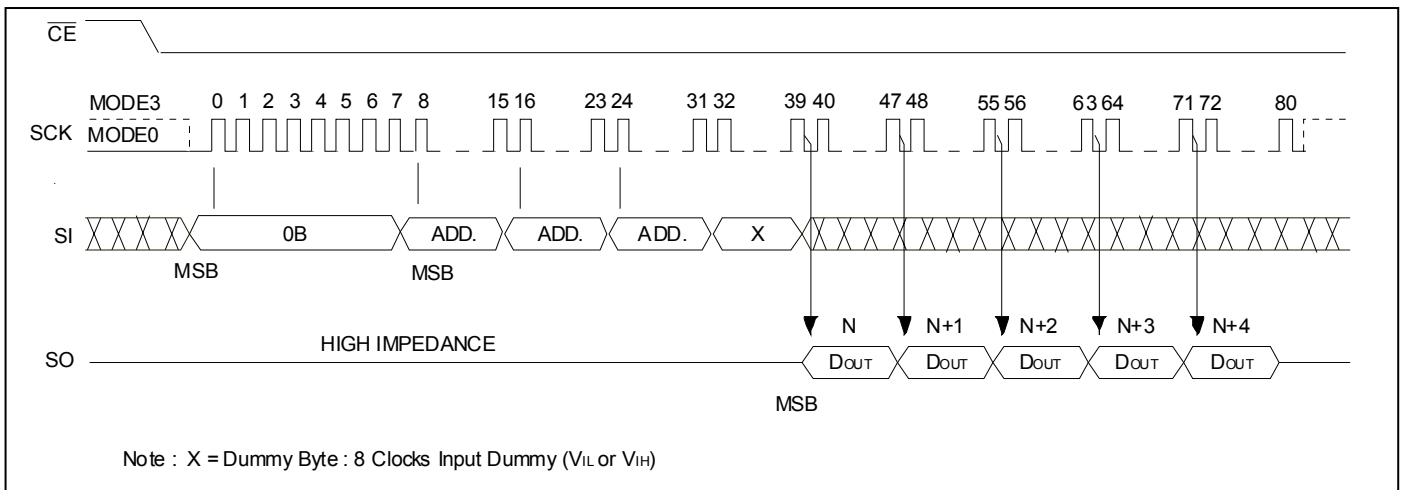

Figure 9-1: Fast Read Sequence (SPI Mode)

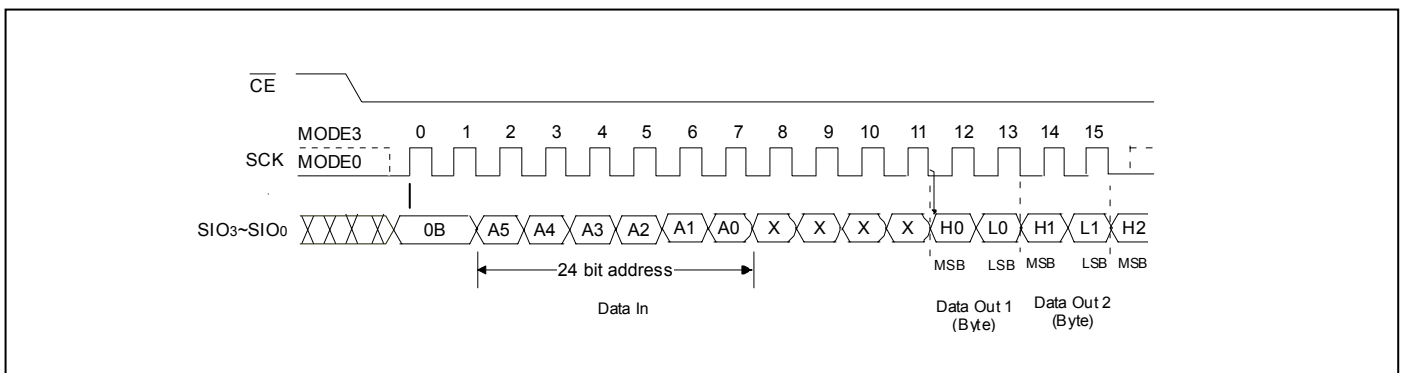

Figure 9-2: Fast Read Sequence (QPI Mode)

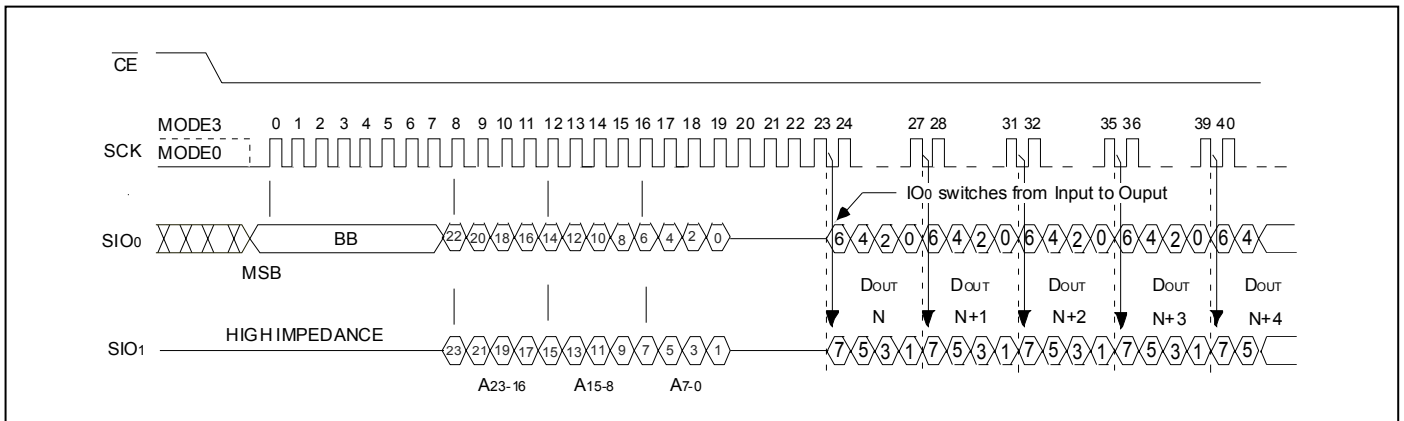

Figure 10: Fast Read Dual I/O (2READ) Sequence

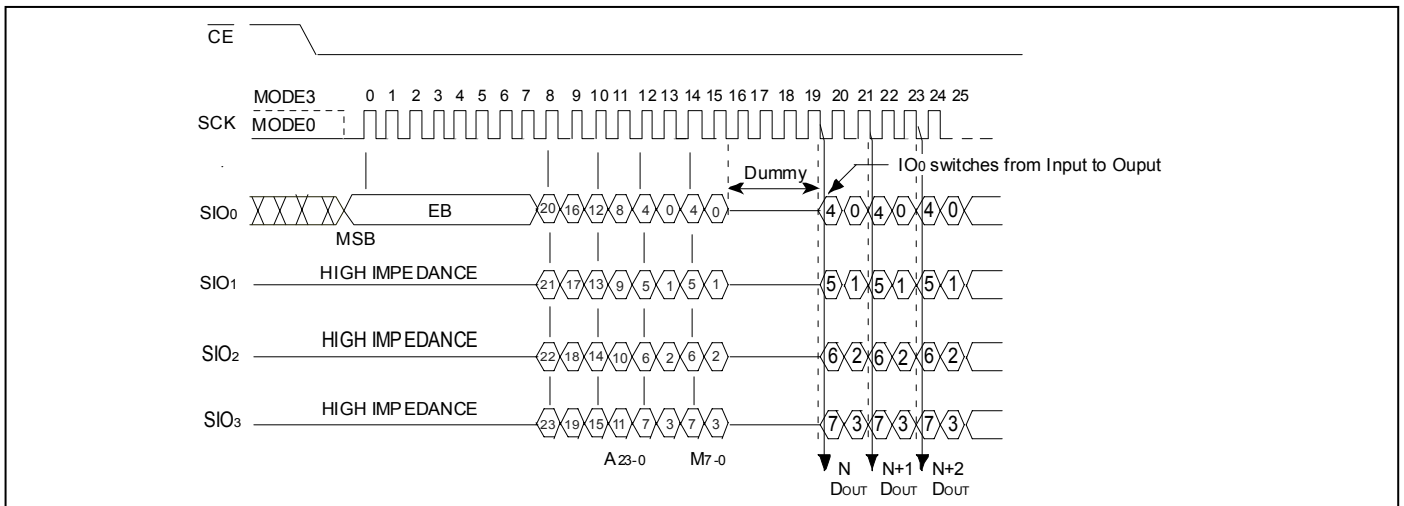

Figure 11-1: Fast Read Quad I/O (4READ) Sequence (SPI Mode)

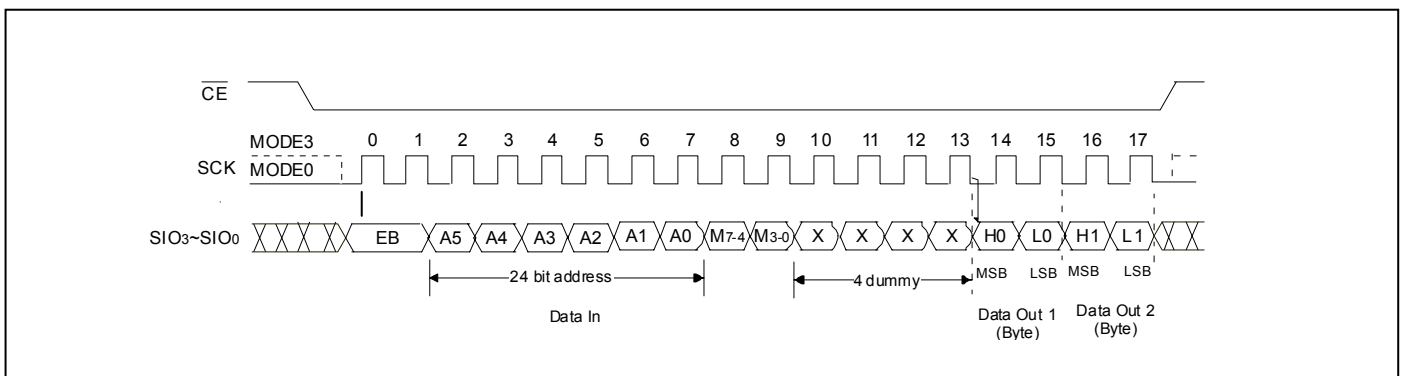

Figure 11-2: Fast Read Quad I/O (4READ) Sequence (QPI Mode)

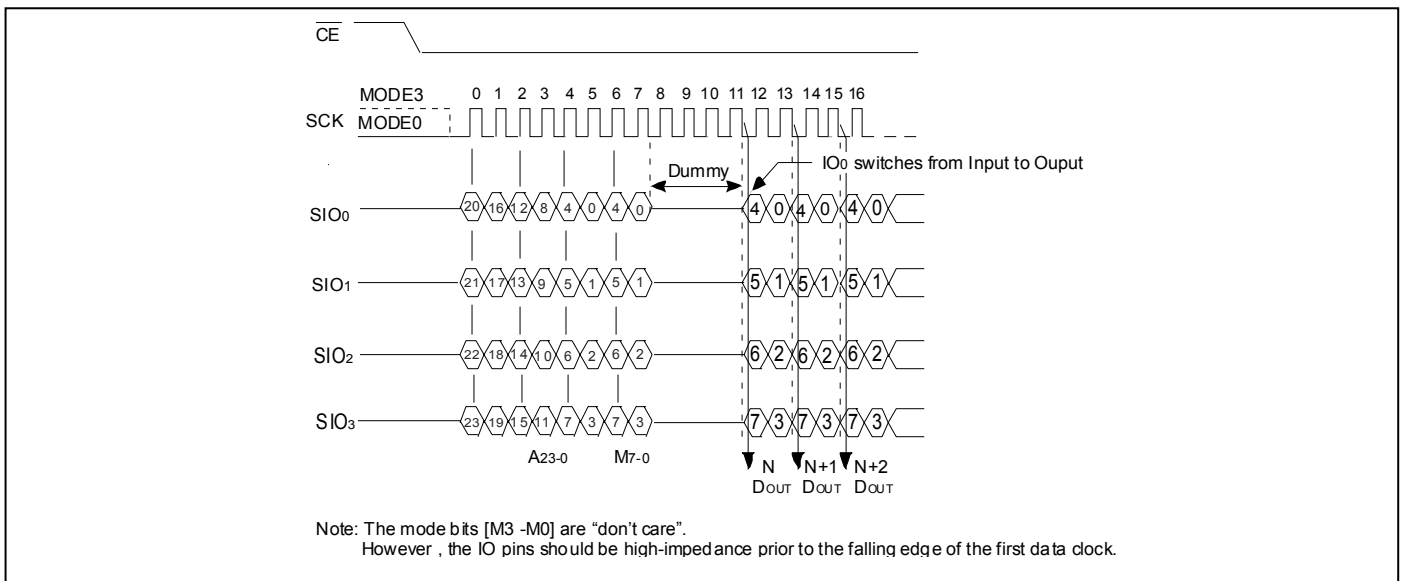

Figure 12-1: Fast Read Quad I/O (4READ) enhance performance Sequence (SPI Mode)

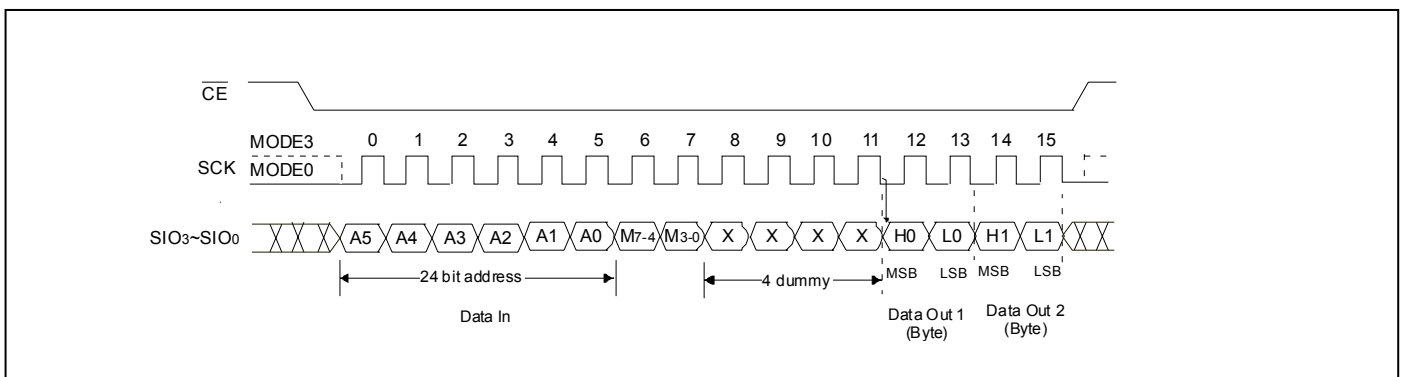

Figure 12-2: Fast Read Quad I/O (4READ) enhance performance Sequence (QPI Mode)

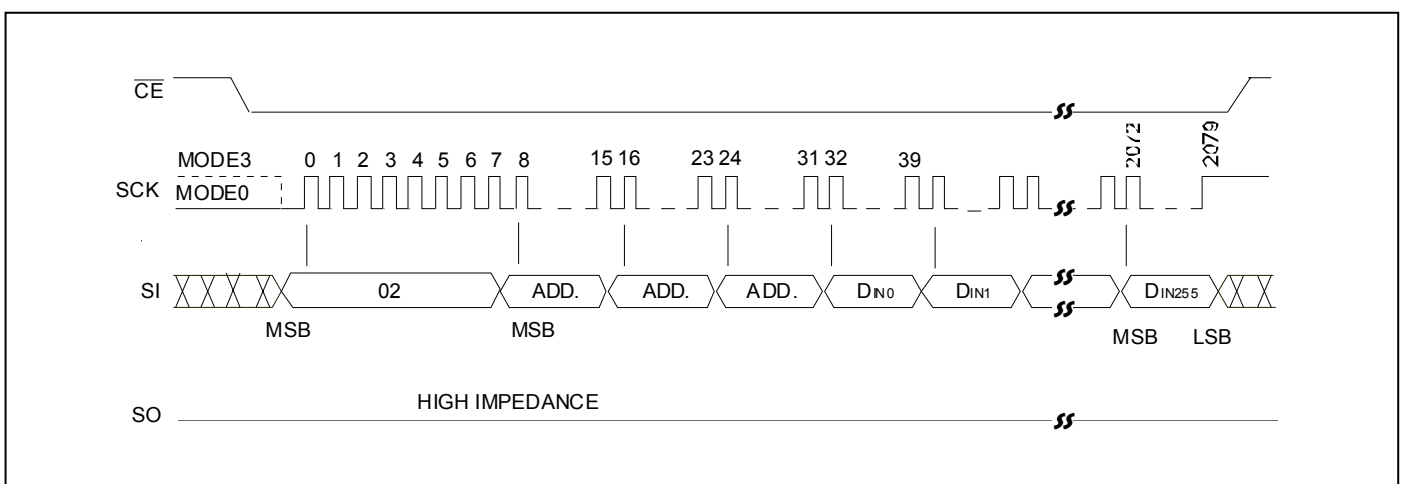

Figure 13-1: Page Program (PP) Sequence (SPI Mode)

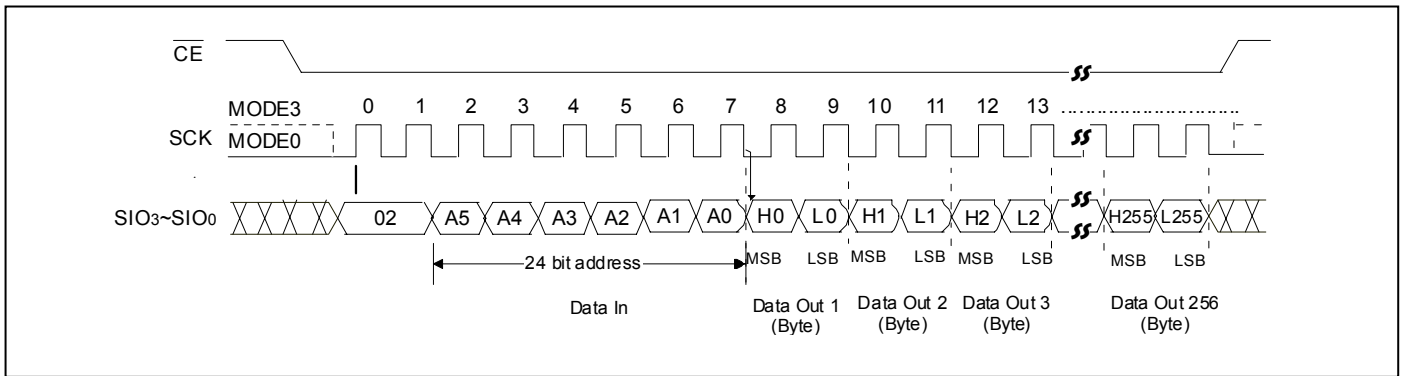

Figure 13-2: Page Program (PP) Sequence (QPI Mode)

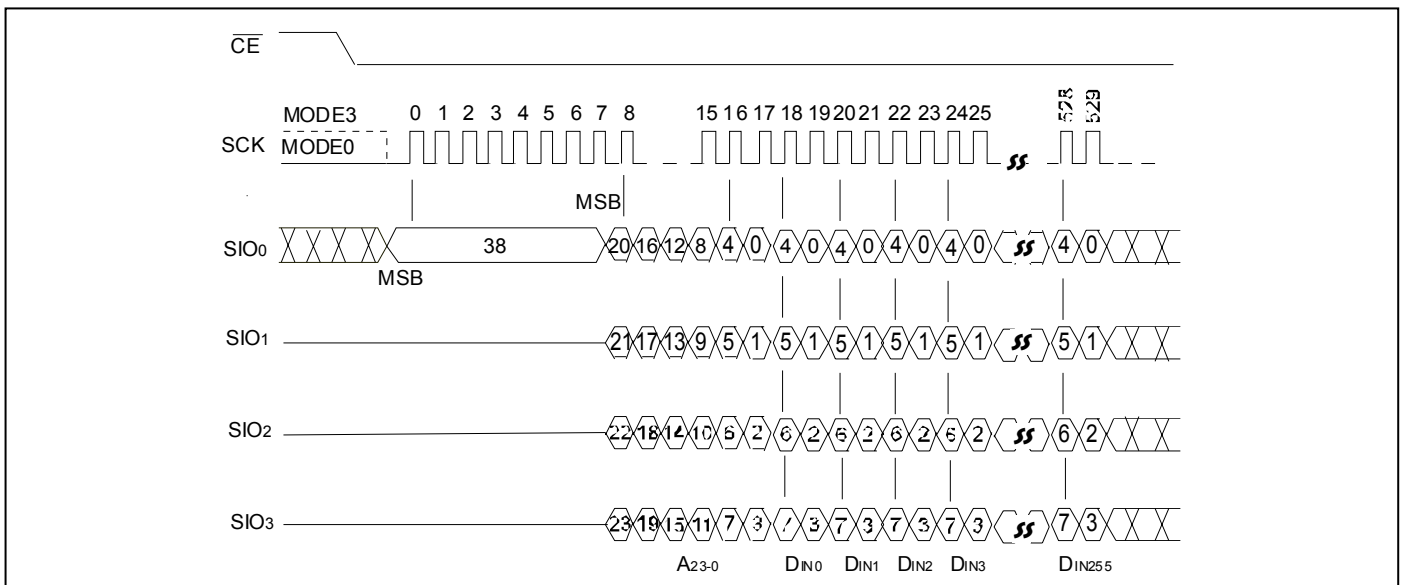

Figure 14: Quad Page Program (4PP) Sequence

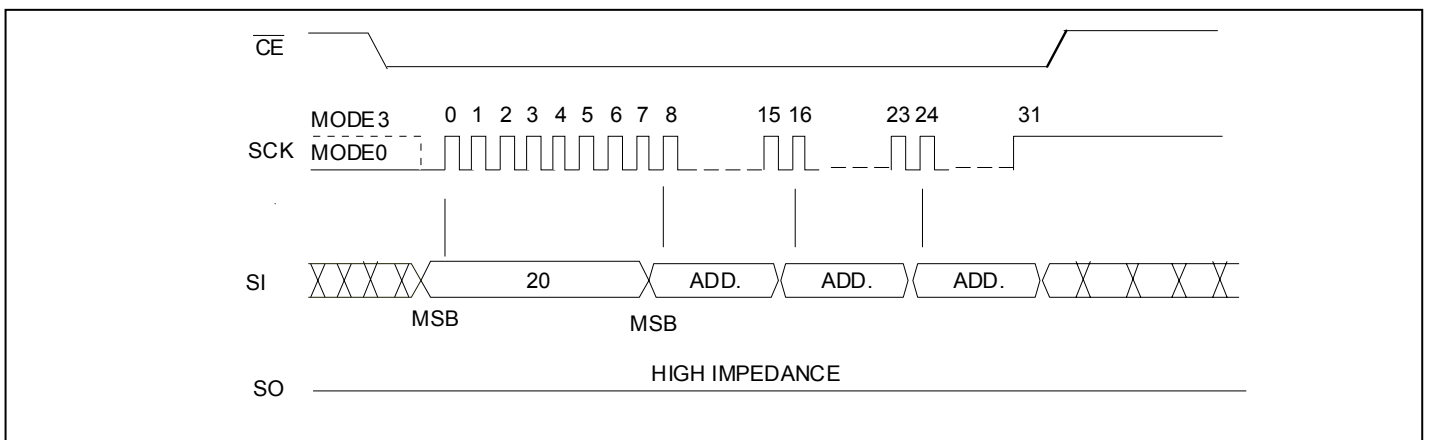

Figure 15-1: Sector Erase (SE) Sequence (SPI Mode)

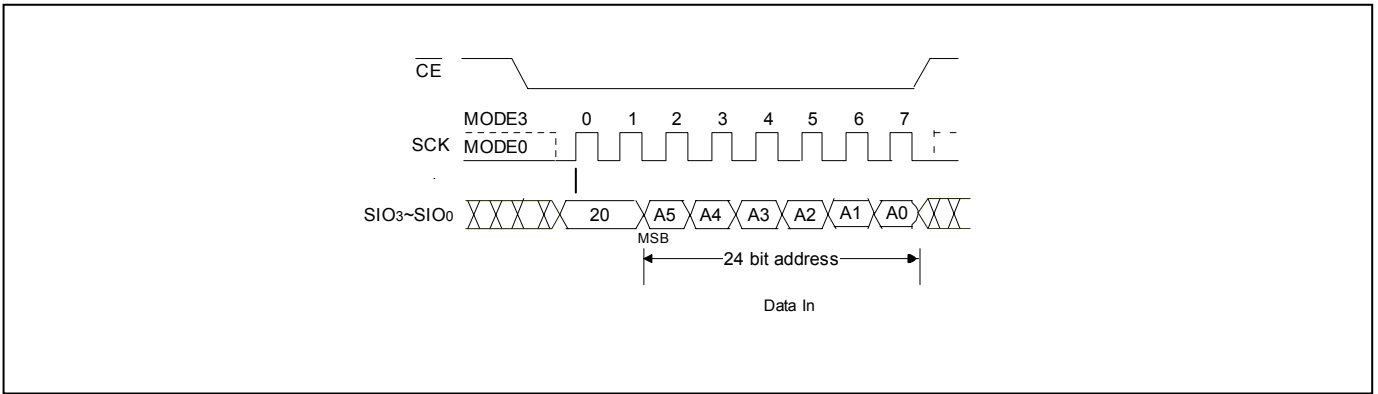

Figure 15-2: Sector Erase (SE) Sequence (QPI Mode)

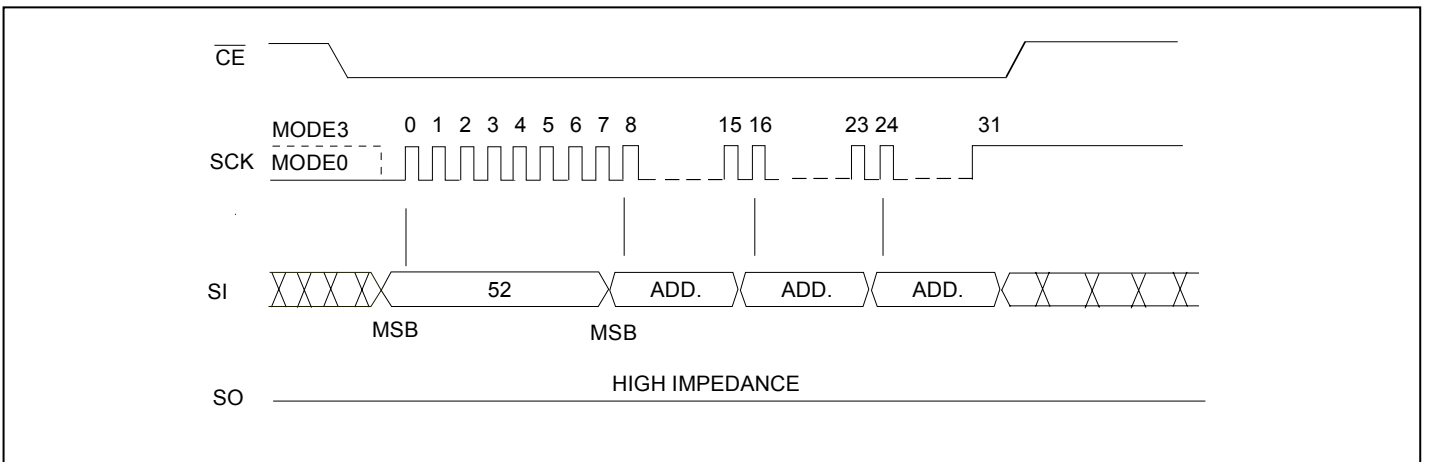

Figure 16-1: 32K-byte Block Erase (BE32K) Sequence (SPI Mode)

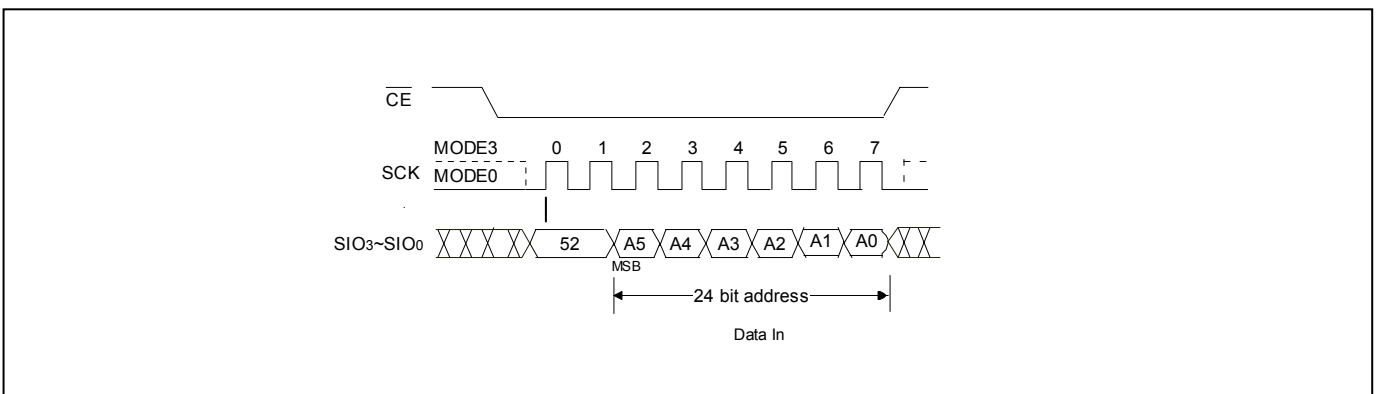

Figure 16-2: 32K-byte Block Erase (BE32K) Sequence (QPI Mode)

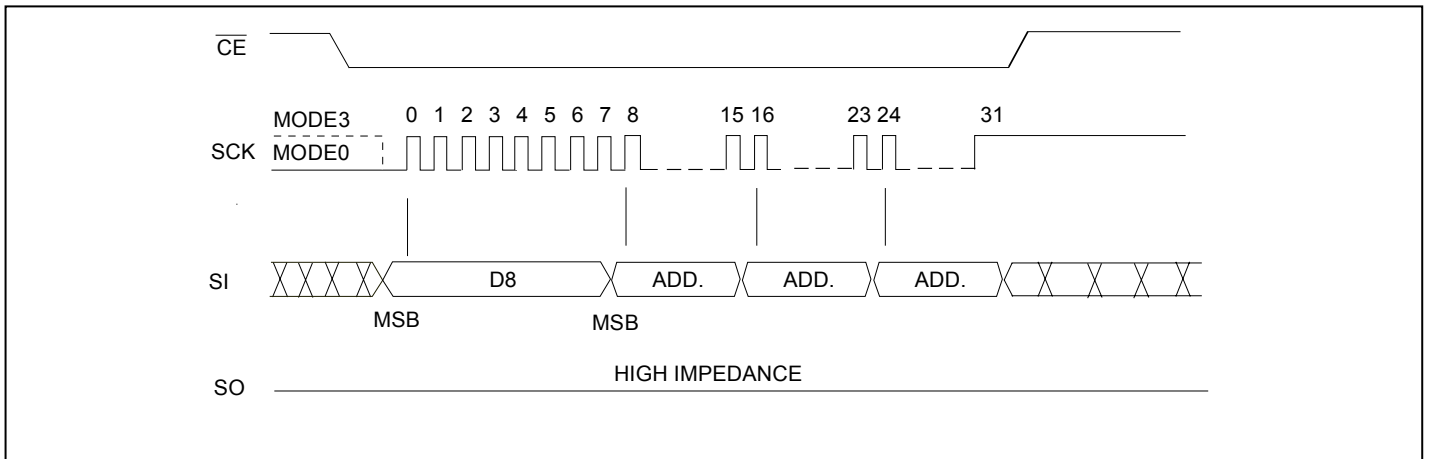

Figure 17-1: 64K-byte Block Erase (BE) Sequence (SPI Mode)

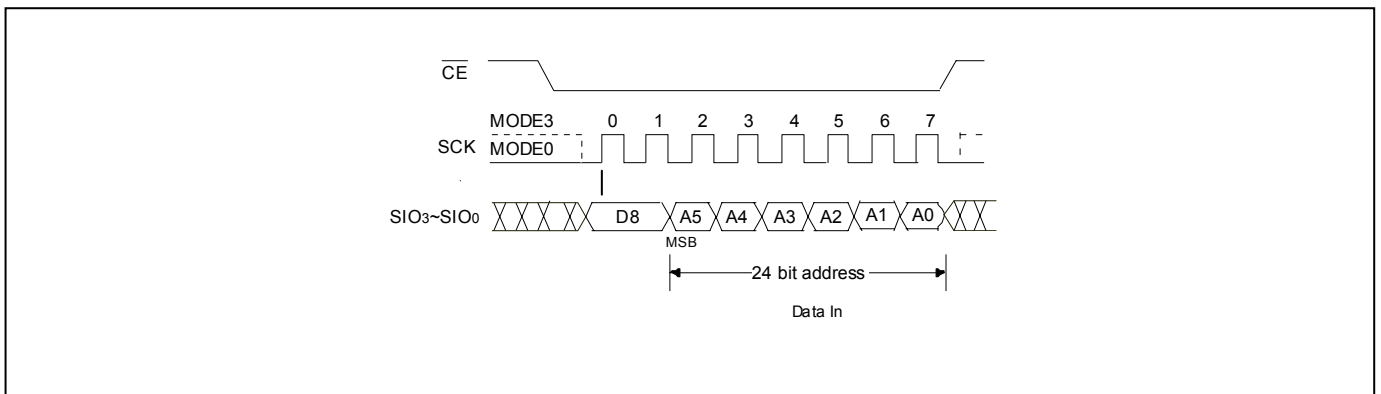

Figure 17-2: 64K-byte Block Erase (BE) Sequence (QPI Mode)

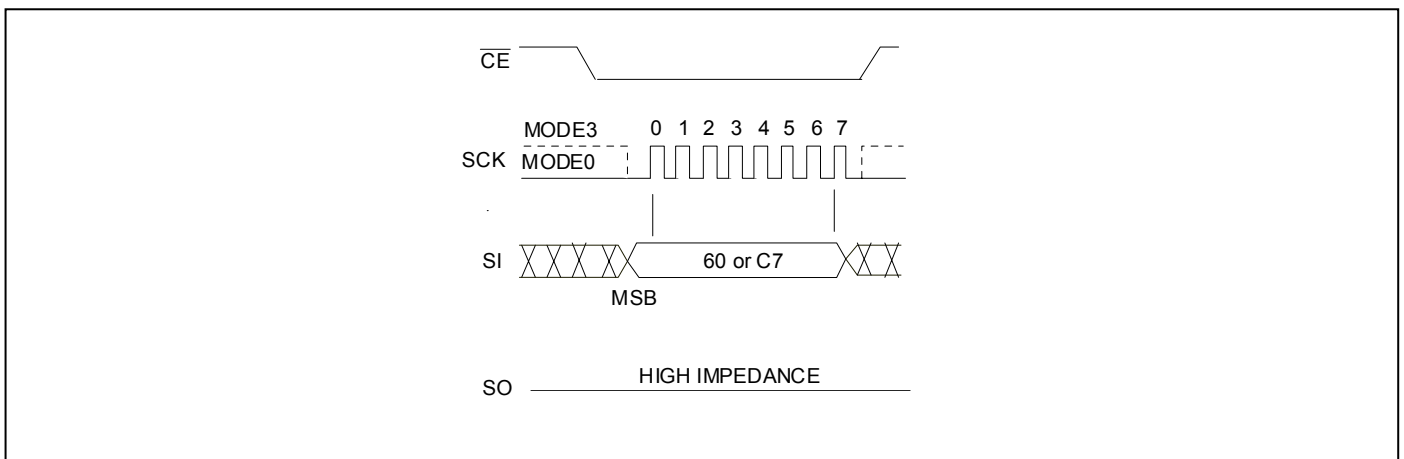

Figure 18-1: Chip Erase (CE) Sequence (SPI Mode)

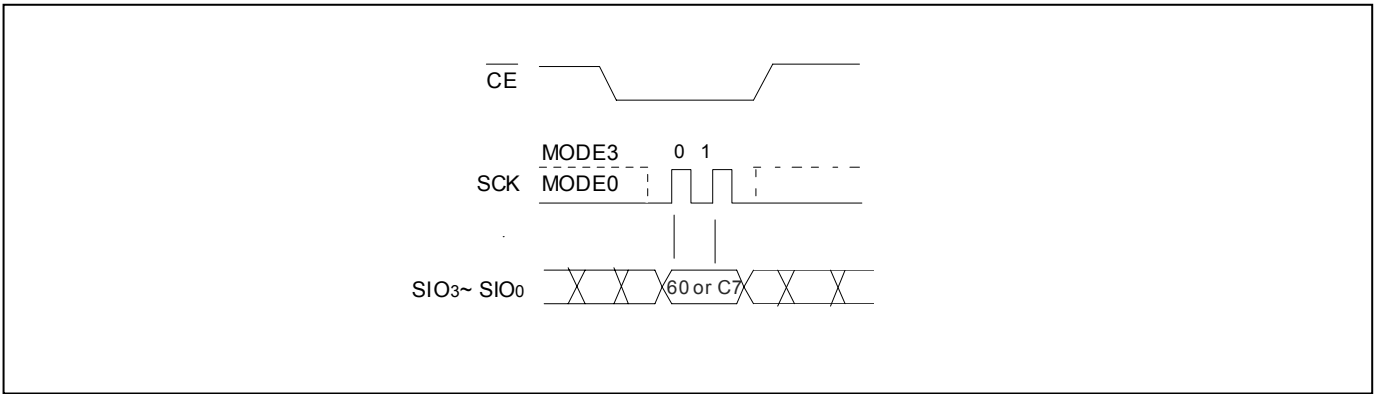

Figure 18-2: Chip Erase (CE) Sequence (QPI Mode)

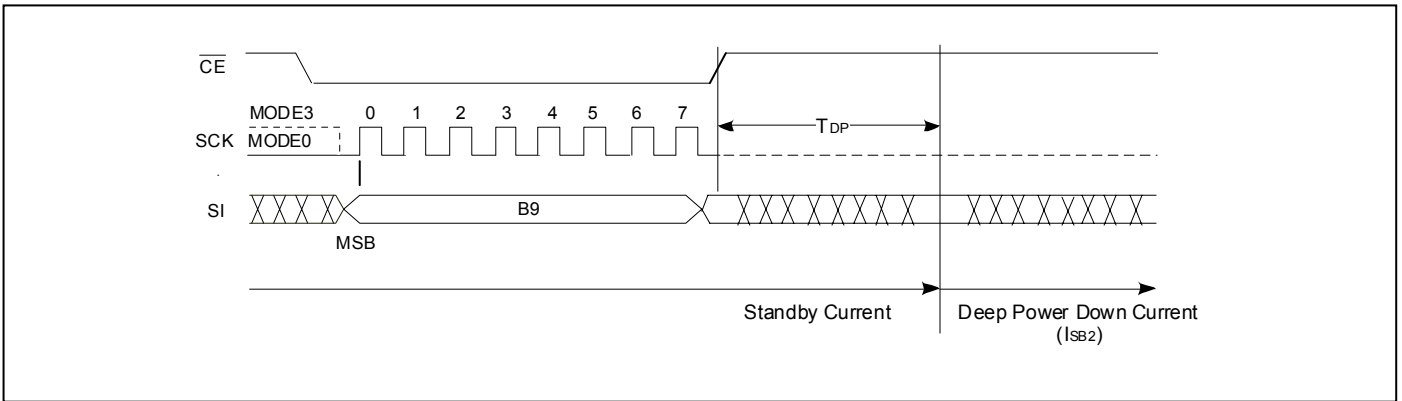

Figure 19-1: Deep Power-down (DP) Instruction (SPI Mode)

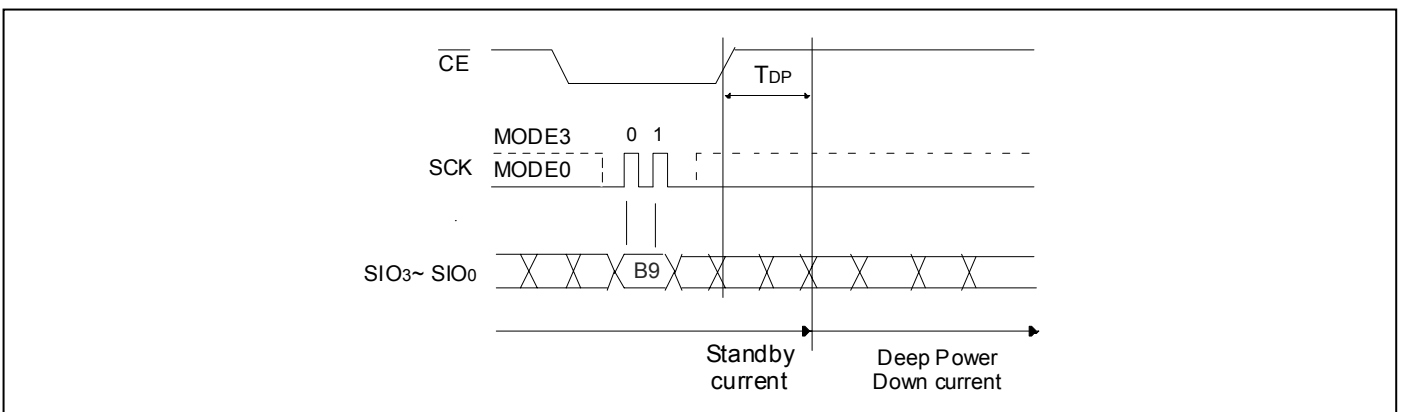

Figure 19-2: Deep Power-down (DP) Instruction (QPI Mode)

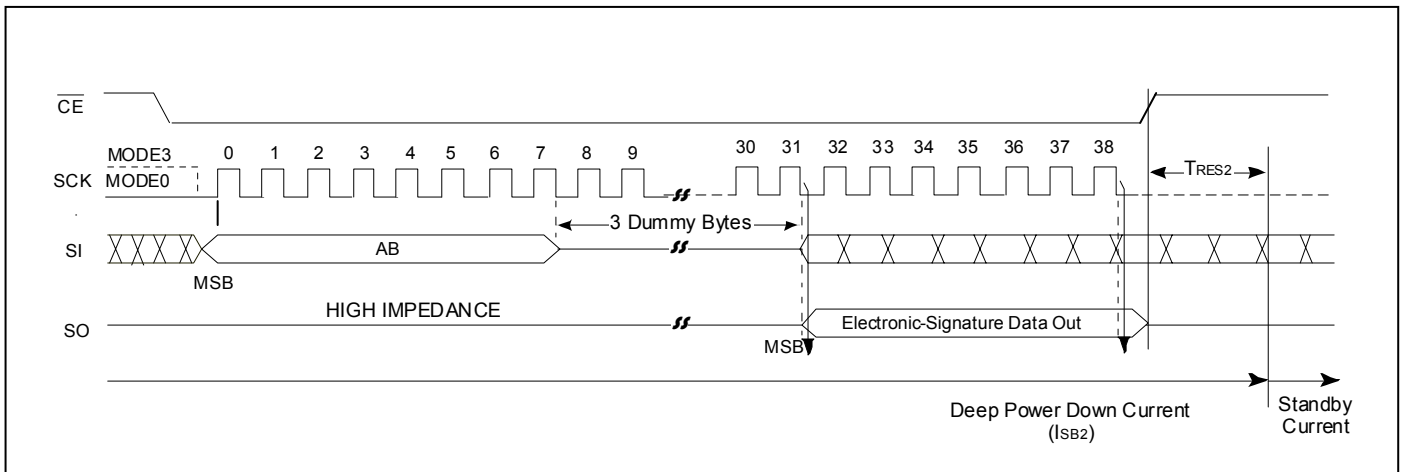

Figure 20-1: Read Electronic Signature (RES) Sequence (SPI Mode)

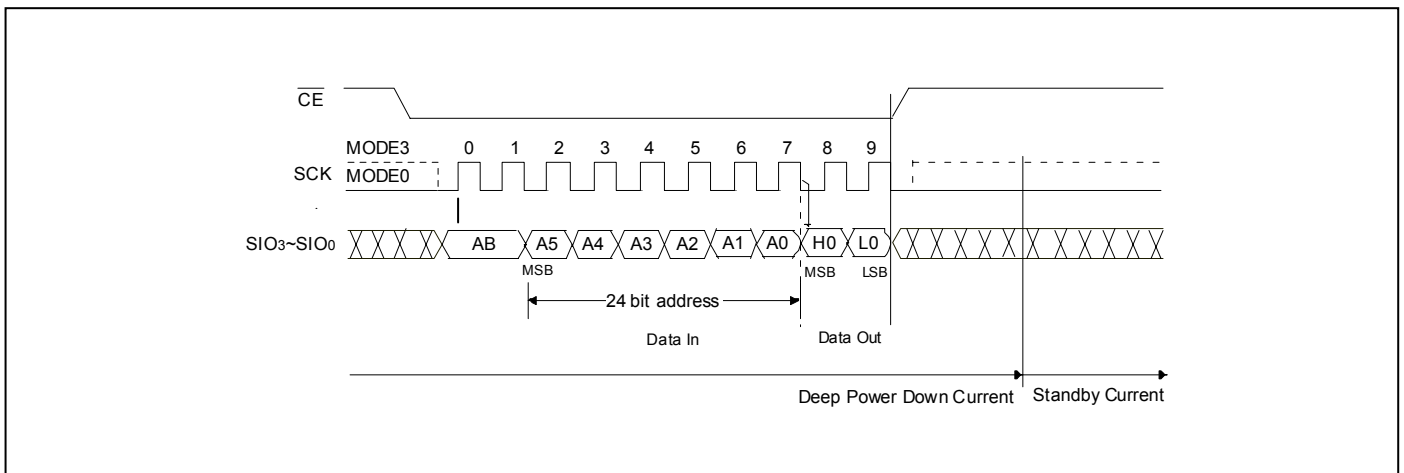

Figure 20-2: Read Electronic Signature (RES) Sequence (QPI Mode)

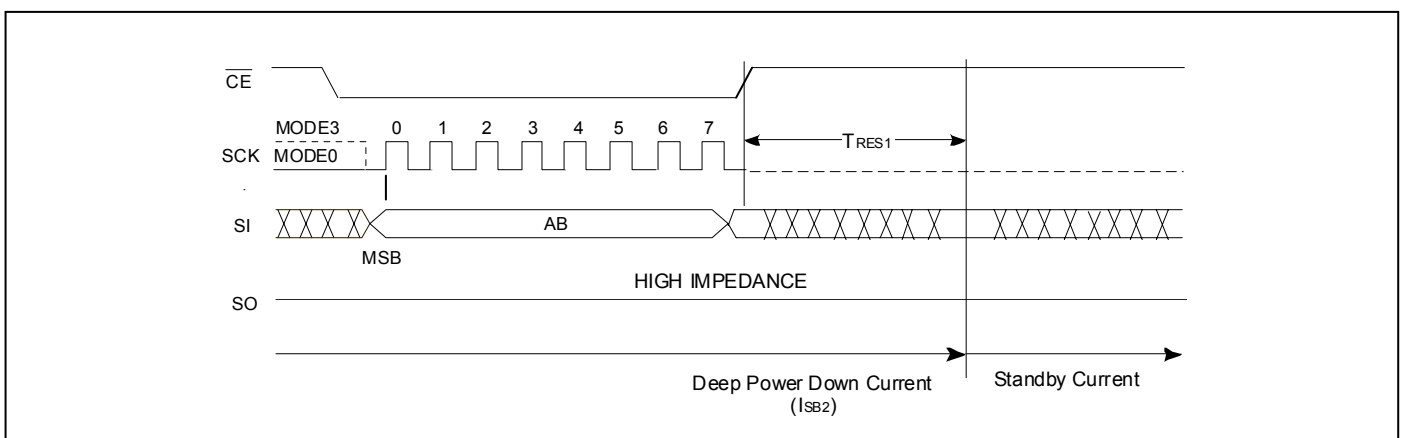

Figure 21-1: Release from Deep Power Down (RDP) Instruction (SPI Mode)

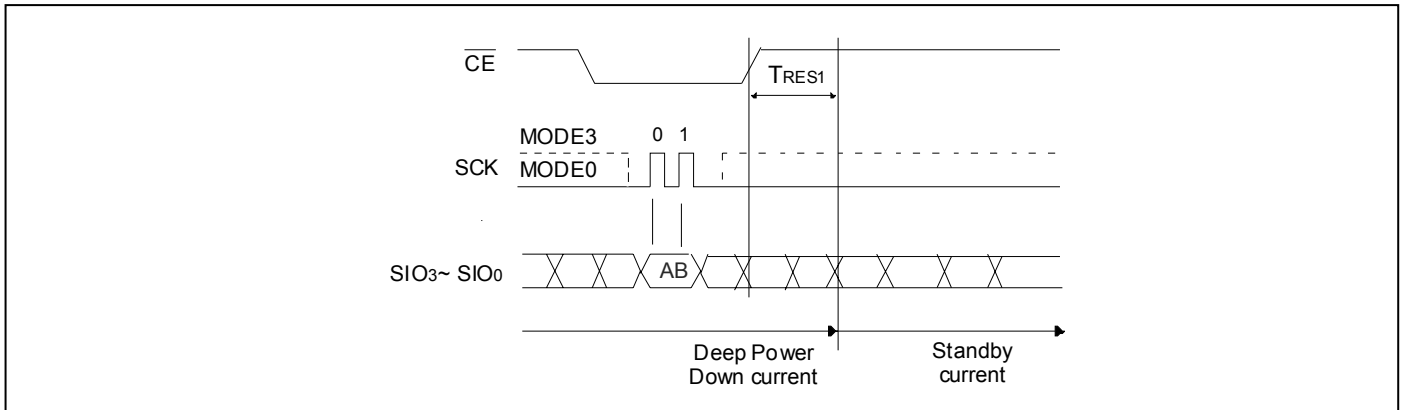

Figure 21-2: Release from Deep Power Down (RDP) Instruction (QPI Mode)

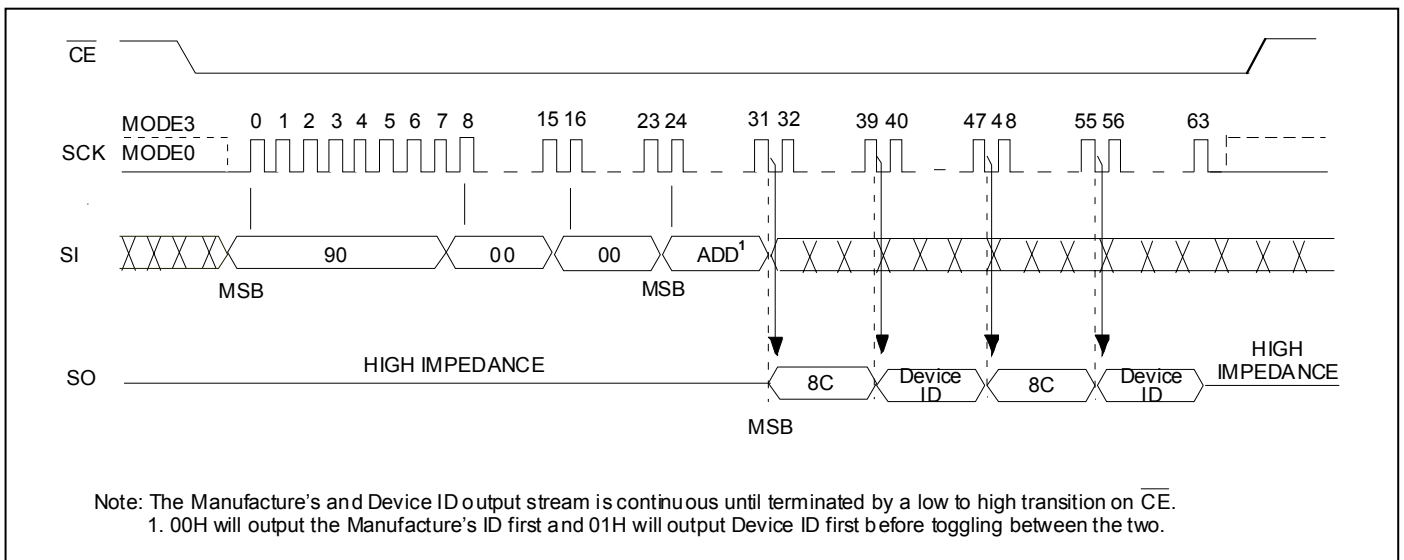

Figure 22: Read Electronic Manufacture ID and Device ID (REMS) Sequence (SPI Mode)

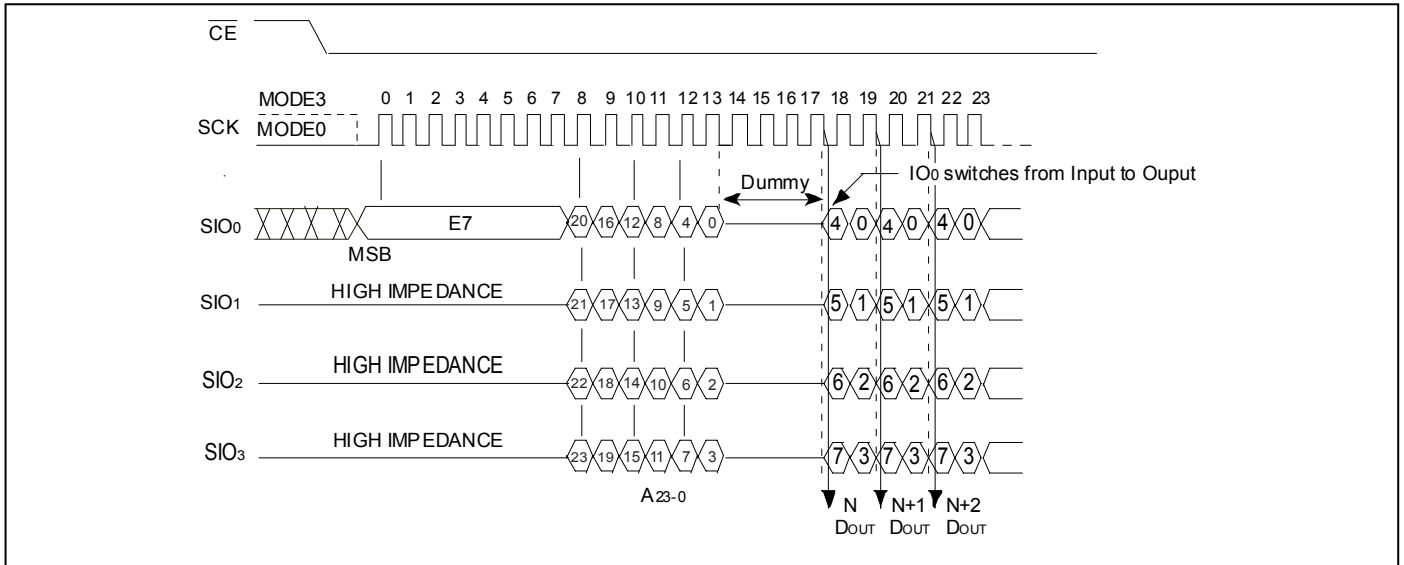

Figure 23: Fast Read Quad I/O (4 dummy cycles) Sequence (SPI Mode)

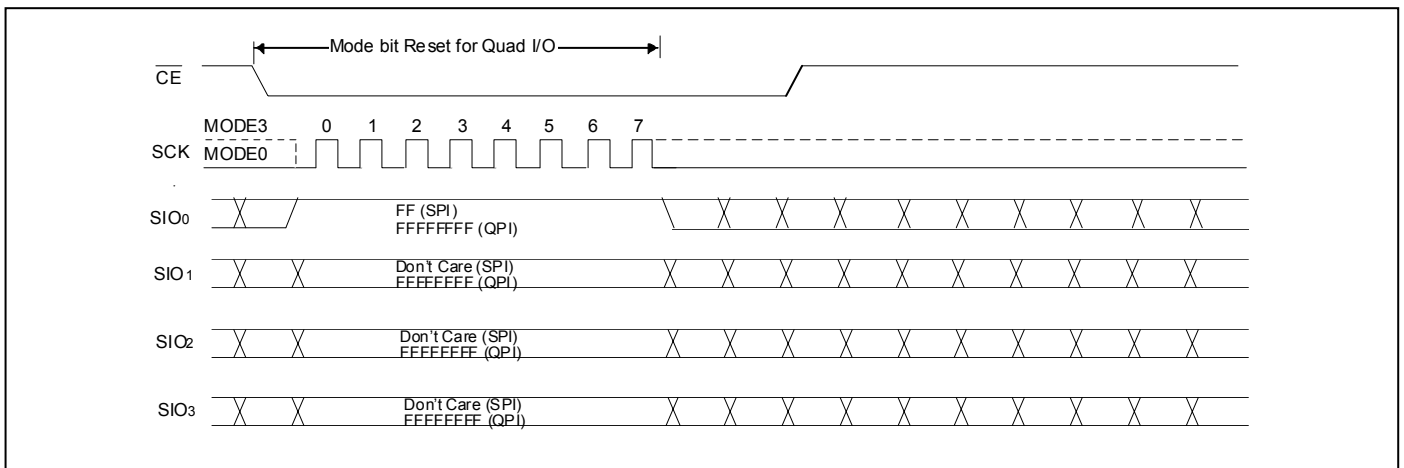

Figure 24: Mode Bit Reset Sequence (SPI and QPI Mode)

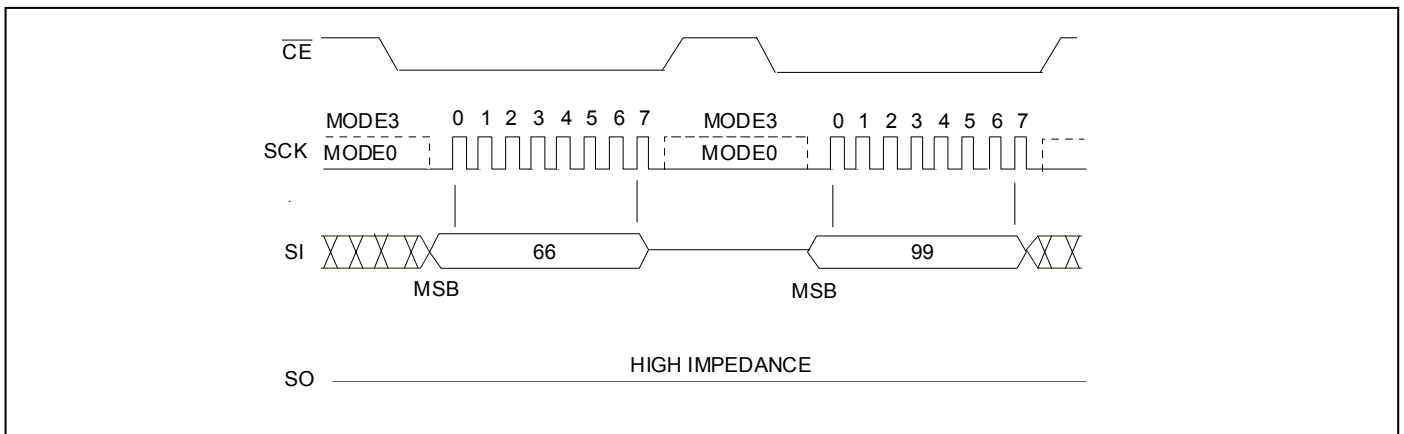

Figure 25-1: Reset Sequence (SPI Mode)

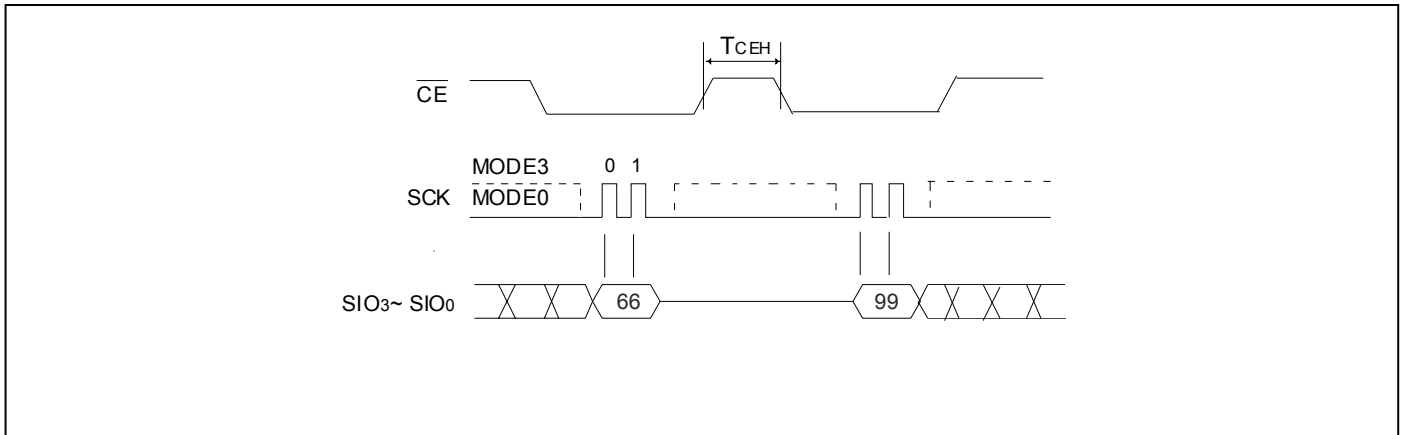

Figure 25-2: Reset Sequence (QPI Mode)

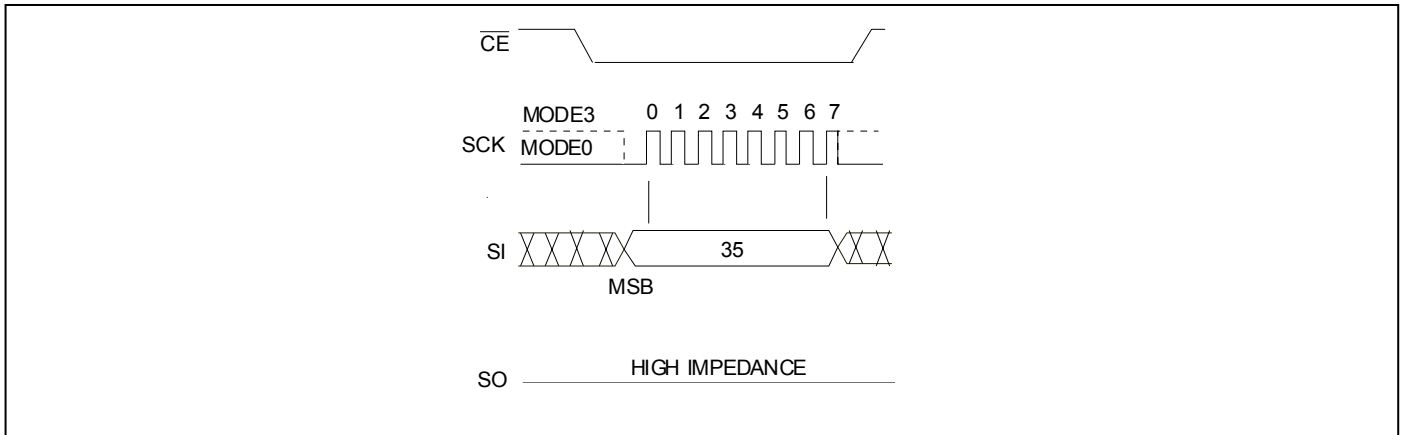

Figure 26: Enable Quad I/O (EQIQ) Sequence

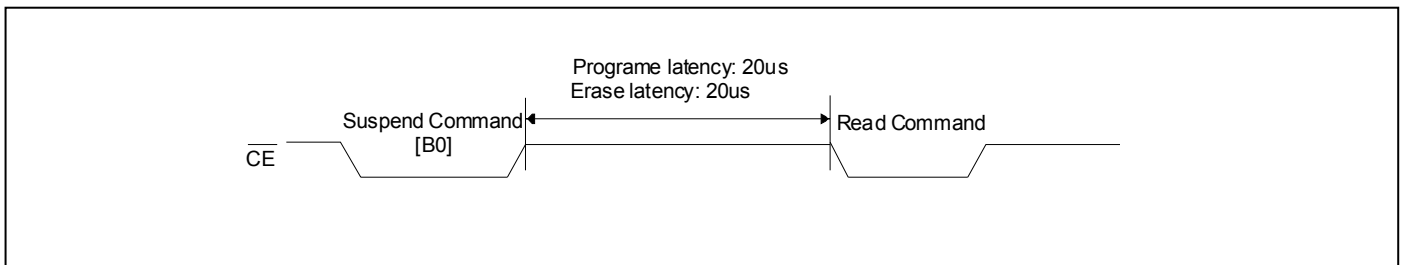

Figure 27-1: Suspend to Read Latency

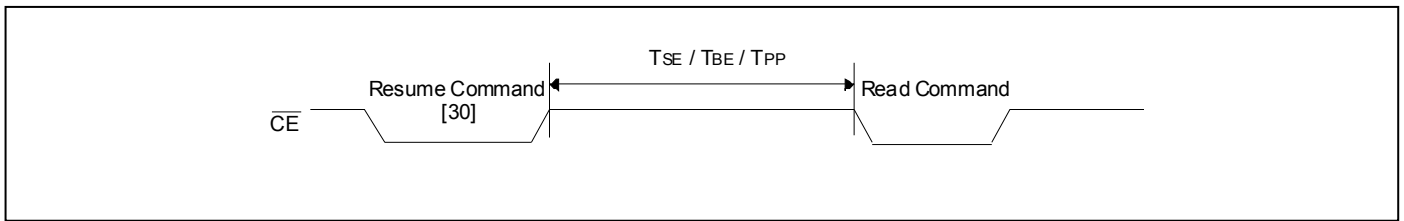

Figure 27-2: Resume to Read Latency



Figure 27-3: Resume to Suspend Latency

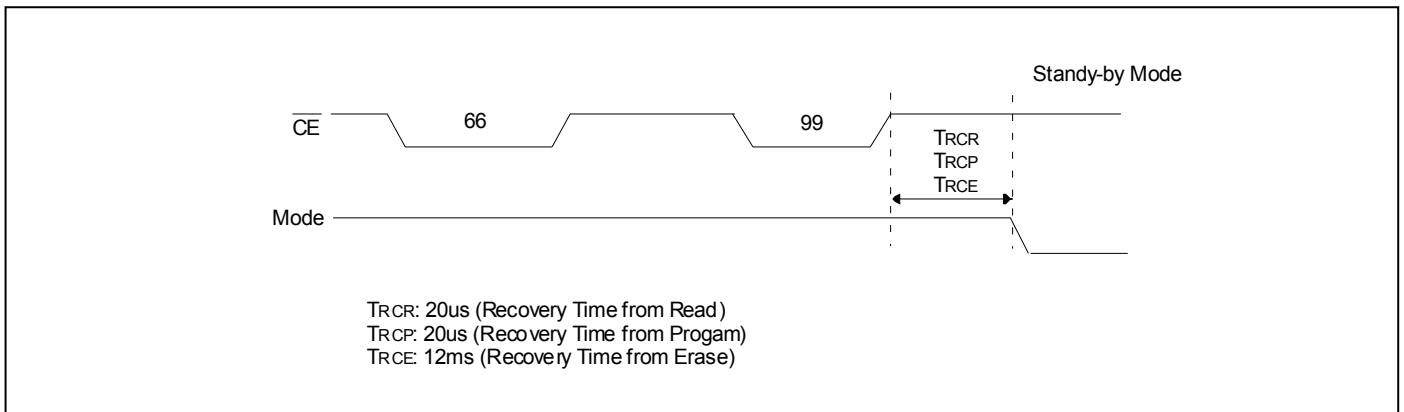

Figure 28: Software Reset Recovery

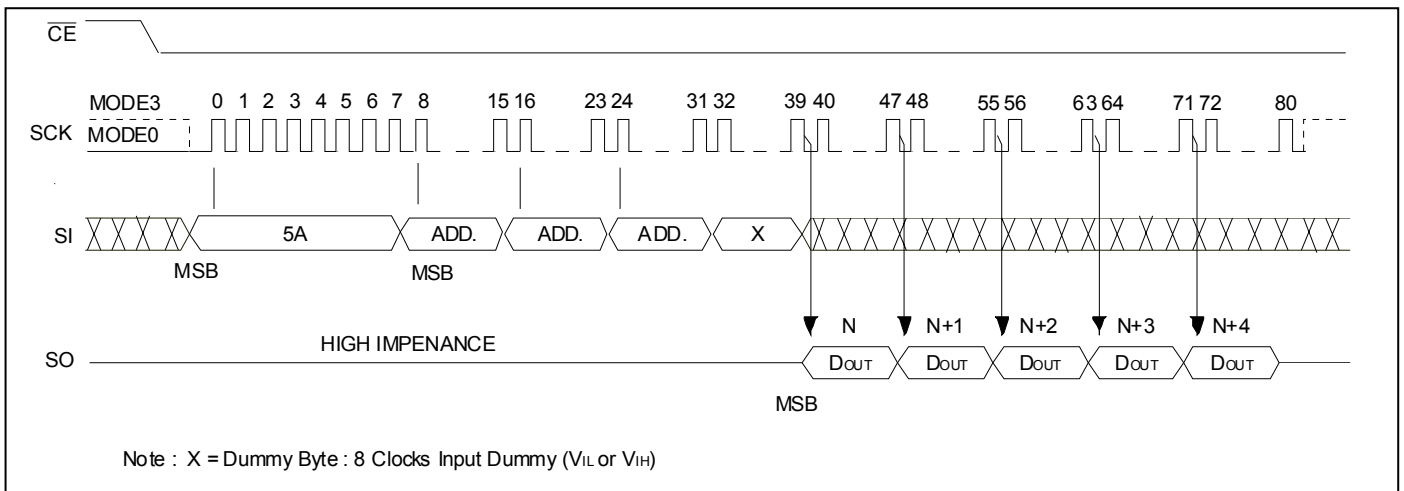

Figure 29-1: Read Serial Flash Discoverable Parameter (RDSFDP) Sequence

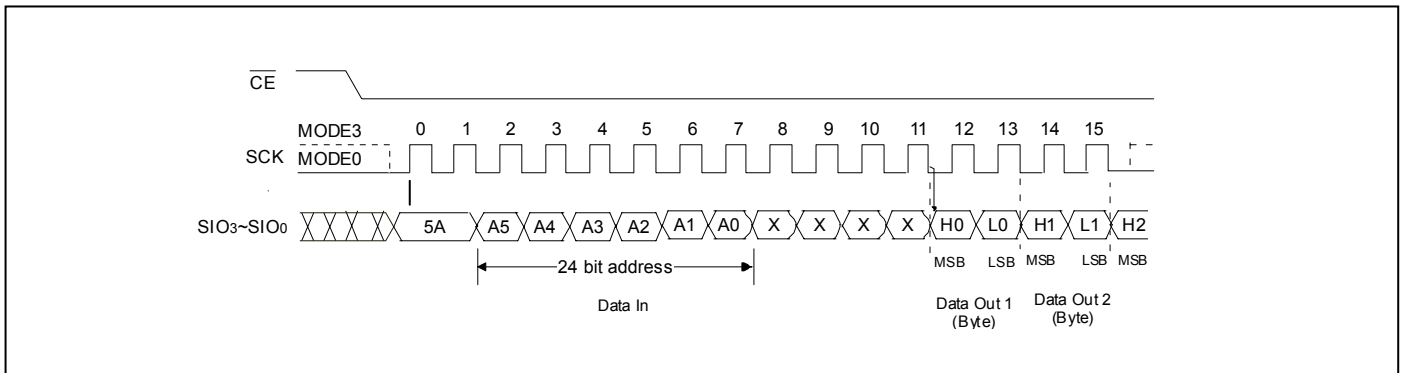

Figure 29-2: Read Serial Flash Discoverable Parameter (RDSFDP) Sequence (QPI Mode)

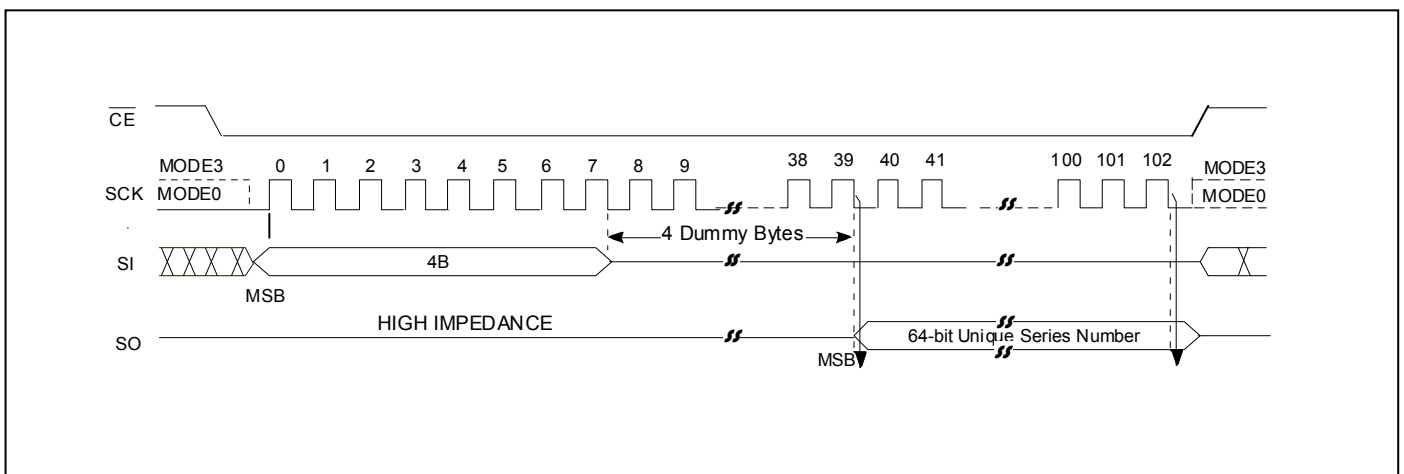

Figure 30: Read Unique ID Number Sequence

■ **ELECTRICAL SPECIFICATIONS**

Absolute Maximum Stress Ratings

(Applied conditions are greater than those listed under “Absolute Maximum Stress Ratings” may cause permanent damage to the device. This is a stress rating only and functional operation of the device at these conditions or conditions greater than those defined in the operational sections of this datasheet is not implied. Exposure to absolute maximum stress rating conditions may affect device reliability.)

Storage Temperature	-65°C to +150°C
D. C. Voltage on Any Pin to Ground Potential	-0.5V to VDD+0.5V
Transient Voltage (<20 ns) on Any Pin to Ground Potential	-0.5V to VDD+1.0V

TABLE 15: AC CONDITIONS OF TEST

Input Rise/Fall Time	5 ns
Output Load	C _L = 15 pF for ≥ 75MHz
.....	C _L = 30 pF for ≤ 50MHz
See Figures 36 and 37	

TABLE 16: OPERATING RANGE

Parameter	Symbol	Value	Unit
Operating Supply Voltage	V _{DD}	1.65~2	V
Ambient Operating Temperature	T _A	-40 ~ +85	°C

TABLE 17: DC OPERATING CHARACTERISTICS

Symbol	Parameter	Limits			Test Condition
		Min	Max	Unit	
I _{DDR1}	Read Current @ 84MHz		15	mA	$\overline{CE} = 0.1 V_{DD}/0.9 V_{DD}$, SO=open
I _{DDR2}	Read Current @ 104MHz		20	mA	$\overline{CE} = 0.1 V_{DD}/0.9 V_{DD}$, SO=open
I _{DDW}	Write Status Register Current		20	mA	$\overline{CE} = V_{DD}$
	Page Program	30(typ.)	35	mA	
I _{DDE}	Sector and Block Erase Current	20 (typ.)	25	mA	$\overline{CE} = V_{DD}$
	Chip Erase Current	20 (typ.)	25	mA	$\overline{CE} = V_{DD}$
I _{SB1}	Standby Current	30 (typ.)	100	μA	$\overline{CE} = V_{DD}$, V _{IN} =V _{DD} or V _{SS}
I _{SB2}	Deep Power Down Current	5 (typ.)	20	μA	$\overline{CE} = V_{DD}$, V _{IN} =V _{DD} or V _{SS}
I _{LI}	Input Leakage Current		±2	μA	V _{IN} =GND to V _{DD} , V _{DD} =V _{DD} Max
I _{LO}	Output Leakage Current		±2	μA	V _{OUT} =GND to V _{DD} , V _{DD} =V _{DD} Max
V _{IL}	Input Low Voltage	-0.5	0.2 x V _{DD}	V	
V _{IH}	Input High Voltage	0.8 x V _{DD}	V _{DD} +0.4	V	
V _{OL}	Output Low Voltage		0.2	V	I _{OL} =100μA
V _{OH}	Output High Voltage	V _{DD} -0.2		V	I _{OH} =-100 μA

TABLE 18: LATCH UP CHARACTERISTIC

Symbol	Parameter	Minimum	Unit	Test Method
I_{LTH}^1	Latch Up	$100 + I_{DD}$	mA	JEDEC Standard 78

Note 1: This parameter is measured only for initial qualification and after a design or process change that could affect this parameter.

TABLE 19: CAPACITANCE (TA = 25°C, f=1 MHz, other pins open)

Parameter	Description	Test Condition	Maximum
C_{OUT}^1	Output Pin Capacitance	$V_{OUT} = 0V$	8 pF
C_{IN}^1	Input Capacitance	$V_{IN} = 0V$	6 pF

Note 1: This parameter is measured only for initial qualification and after a design or process change that could affect this parameter.

TABLE 20: AC OPERATING CHARACTERISTICS

Symbol	Parameter	Min.	Typ.	Max.	Unit
F_{SCLK}	Serial Clock Frequency for FAST_READ, PP, SE, BE, CE, DP, RES, RDP, WREN, WRDI, RDID, RDSR, RDCR, WRSR instruction			104	MHz
F_{RSCLK}	Serial Clock Frequency for READ instruction			50	MHz
F_{TSCLK1}^5	Serial Clock Frequency for 2READ instruction			84	MHz
F_{TSCLK2}^5	Serial Clock Frequency for 4READ instruction			84	MHz
T_{SCKH}	Serial Clock High Time	Serial (F_{SCLK})	4.5		ns
		4PP and Normal Read (F_{RSCLK})	9		ns
T_{SCKL}	Serial Clock Low Time	Serial (F_{SCLK})	4.5		ns
		4PP and Normal Read (F_{RSCLK})	9		ns
T_{CLCH}^2	Clock Rise Time (peak to peak)	0.1			V/ns
T_{CHCL}^2	Clock Fall Time (peak to peak)	0.1			V/ns
T_{CES}^1	\overline{CE} Active Setup Time	5			ns
T_{CEH}^1	\overline{CE} Active Hold Time	5			ns
T_{CHS}^1	\overline{CE} Not Active Setup Time	5			ns
T_{CHH}^1	\overline{CE} Not Active Hold Time	5			ns
T_{CPH}	\overline{CE} High Time	Read	7		ns
		Write / Erase / Program	30		ns
T_{CHZ}	\overline{CE} High to High-Z Output			8	ns
T_{CLZ}	SCK Low to Low-Z Output	0			ns
T_{DS}	Data In Setup Time	2			ns
T_{DH}	Data In Hold Time	5			ns

TABLE 20: AC OPERATING CHARACTERISTICS - Continued

Symbol	Parameter		Min.	Typ.	Max.	Unit	
T _{OH}	Output Hold from SCK Change		0			ns	
T _V	Output Valid from SCK	Loading: 30pF			8	ns	
		Loading: 15pF			6	ns	
T _{WHSL} ⁴	Write Protect Setup Time before \overline{CE} Low				20	ns	
T _{SHWL} ⁴	Write Protect Hold Time after \overline{CE} High				100	ns	
T _{DP} ³	\overline{CE} High to Deep Power Down Mode				10	us	
T _{RES1} ³	\overline{CE} High to Standby Mode (for DP)				10	us	
T _{RES2} ³	\overline{CE} High to Standby Mode (for RES)				10	us	
T _{SUS} ³	\overline{CE} High to next Instruction after Suspend				20	us	
T _{RLRH}	Reset Pulse Width		1			us	
T _{RS}	Reset Setup Time		15			ns	
T _{RH}	Reset Hold Time		15			ns	
T _{RHRL}		Reset Recovery Time (During instruction decoding)			20	us	
	T _{RCR}	Reset Recovery time from read			20	us	
	T _{RCP}	Reset Recovery time from program			20	us	
	T _{RCE}	Reset Recovery time from erase (for Sector Erase)				10	ms
		Reset Recovery time from erase (for 32KB Block Erase)				70	ms
		Reset Recovery time from erase (for 64KB Block Erase)				140	ms
	Reset Recovery Time (for WRSR operation)				40	ms	

- Note:
1. Relative to SCK.
 2. T_{SCKH} + T_{SCKL} must be less than or equal to 1/ F_{CLK}.
 3. Value guaranteed by characterization, not 100% tested in production.
 4. Only applicable as a constraint for a Write status Register instruction when Block- Protection-Look (BPL) bit is set at 1.
 5. By default dummy cycle value.

■ TABLE 21: ERASE AND PROGRAMMING PERFORMANCE

Parameter	Symbol	Limit		Unit
		Typ ²	Max ³	
Sector Erase Time (4KB)	T _{SE}	40	200	ms
Block Erase Time (32KB)	T _{BE1}	200	1000	ms
Block Erase Time (64KB)	T _{BE2}	0.4	2	s
Chip Erase Time	T _{CE}	90	200	s
Write Status / Configuration Register Time	T _W		40	ms
Page Programming Time	T _{PP}	0.9	3	ms
Erase/Program Cycles ¹		100,000	-	Cycles
Data Retention		20	-	Years

Notes:

1. Not 100% Tested, Excludes external system level over head.
2. Typical values measured at 25°C, 1.8V.
3. Maximum values measured at 85°C, 1.65V.

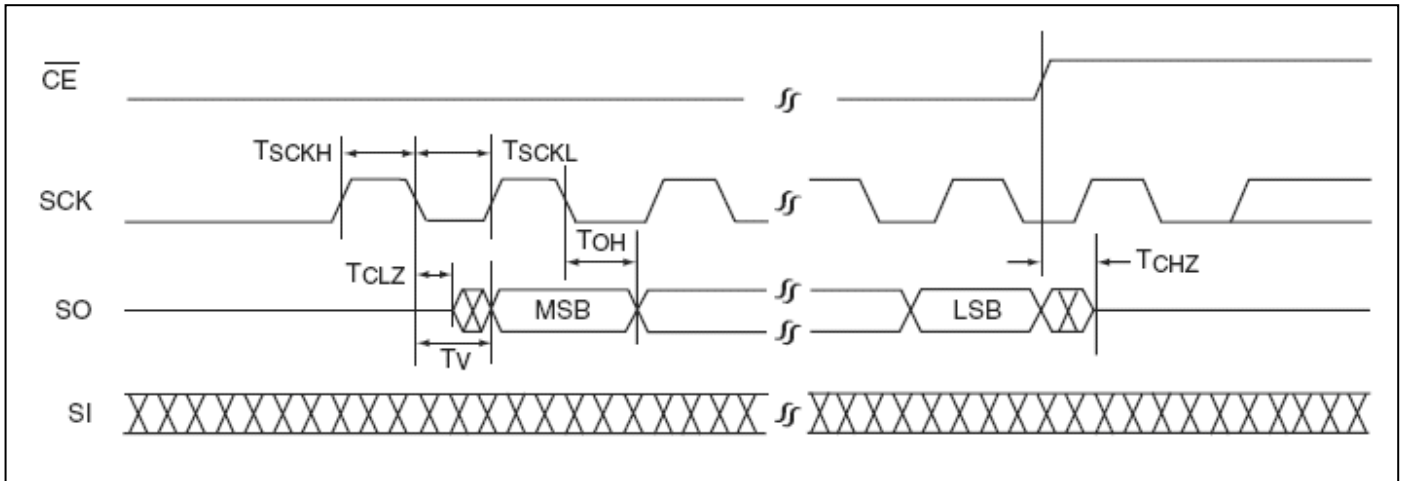

Figure 31: Serial Output Timing Diagram

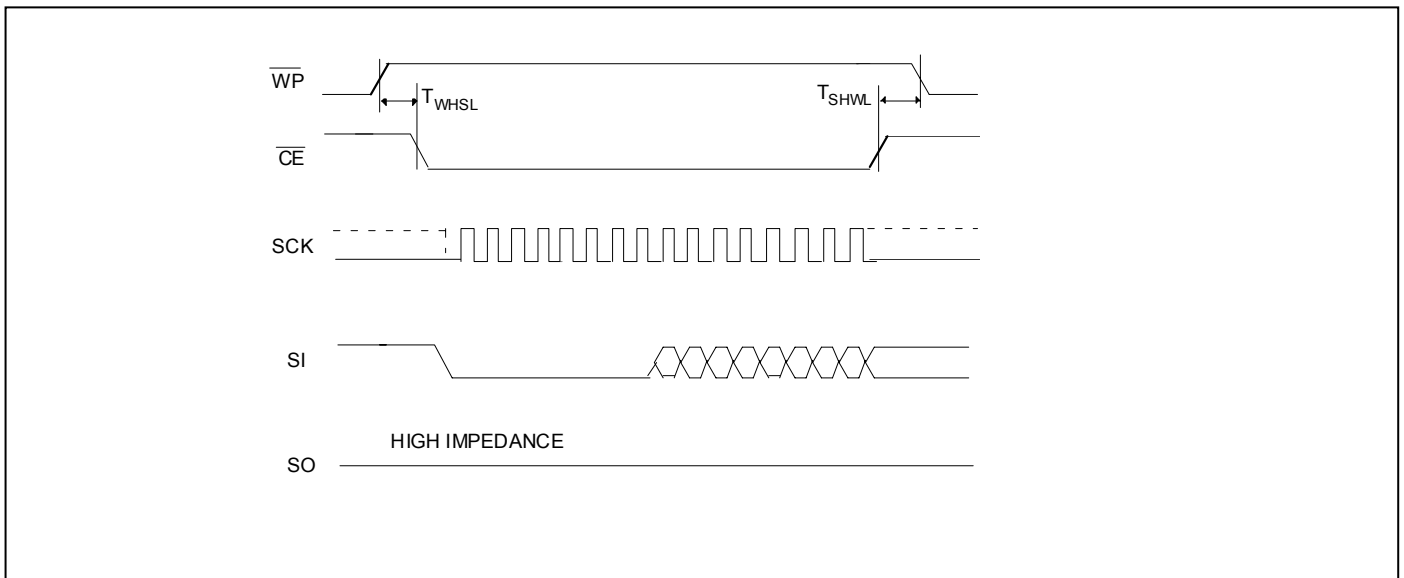

Figure 32: Write Protect setup and hold timing during WRSR when $BPL = 1$

At Device Power-Up and Power-Down

AC timing illustrated in Figure 33 ~ 34 are for the supply voltages and the control signals at device power-up and power-down. If the timing in the figures is ignored, the device will not operate correctly.

During power-up and power-down, \overline{CE} needs to follow the voltage applied on V_{DD} to keep the device not to be select. The \overline{CE} can be driven low when V_{DD} reach $V_{DD}(\min)$ and wait a period of t_{VSL} .

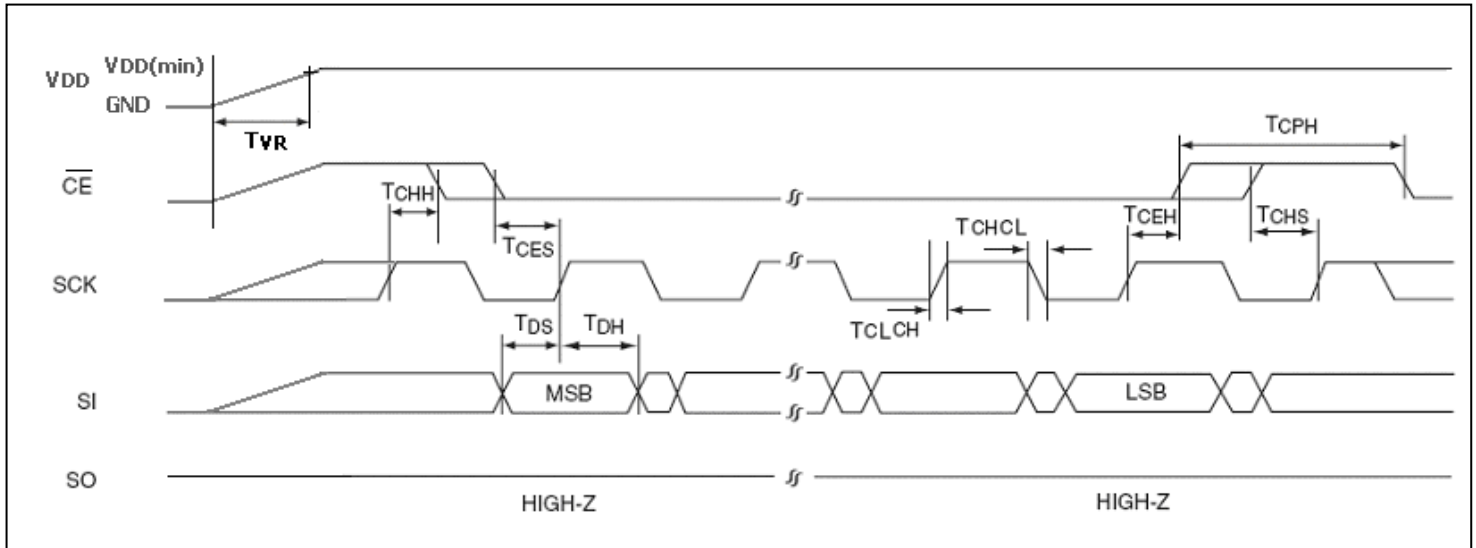

Figure 33: AC Timing at Device Power-Up

Parameter	Symbol	Min.	Max.	Unit
V_{DD} Rise Time	T_{VR}	20	500000	us/V

Note: Sampled not 100% tested.

During power-down, \overline{CE} needs to follow the voltage drop on V_{DD} to avoid mis-operation.

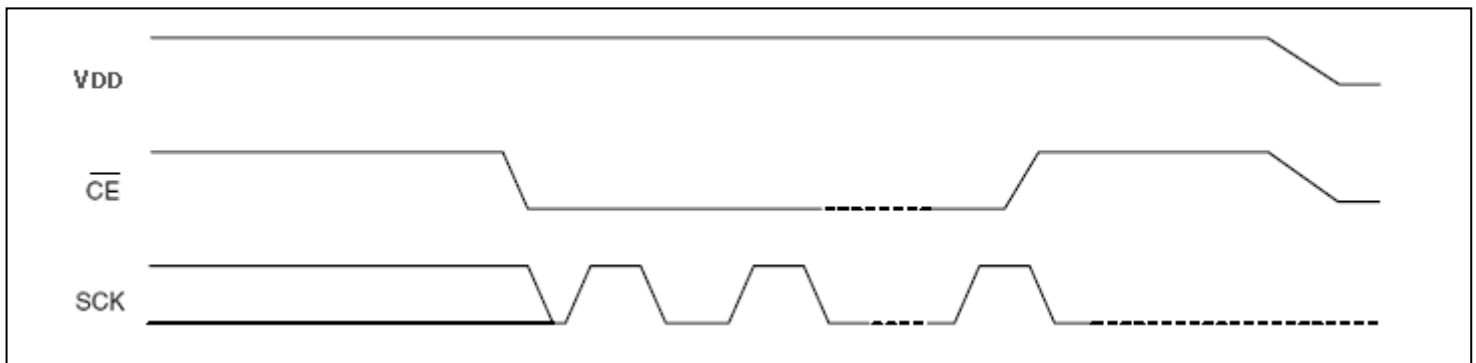

Figure 34: Power-Down Sequence

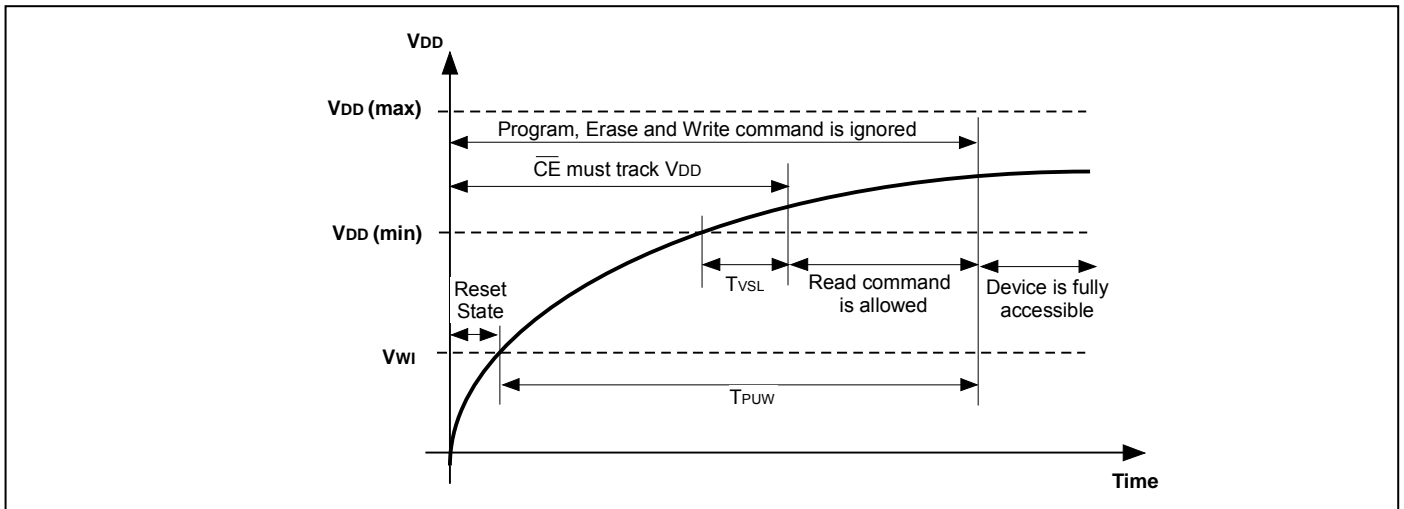

Figure 35: Power-Up Timing Diagram

Table 22: Power-Up Timing and V_{wi} Threshold

Parameter	Symbol	Min.	Max.	Unit
V _{DD} (min) to \overline{CE} low	T _{VSL}	300		us
Time Delay before Write instruction	T _{PUW}	1	10	ms
Write Inhibit Threshold Voltage	V _{wi}	1	1.4	V

Note: These parameters are characterized only.

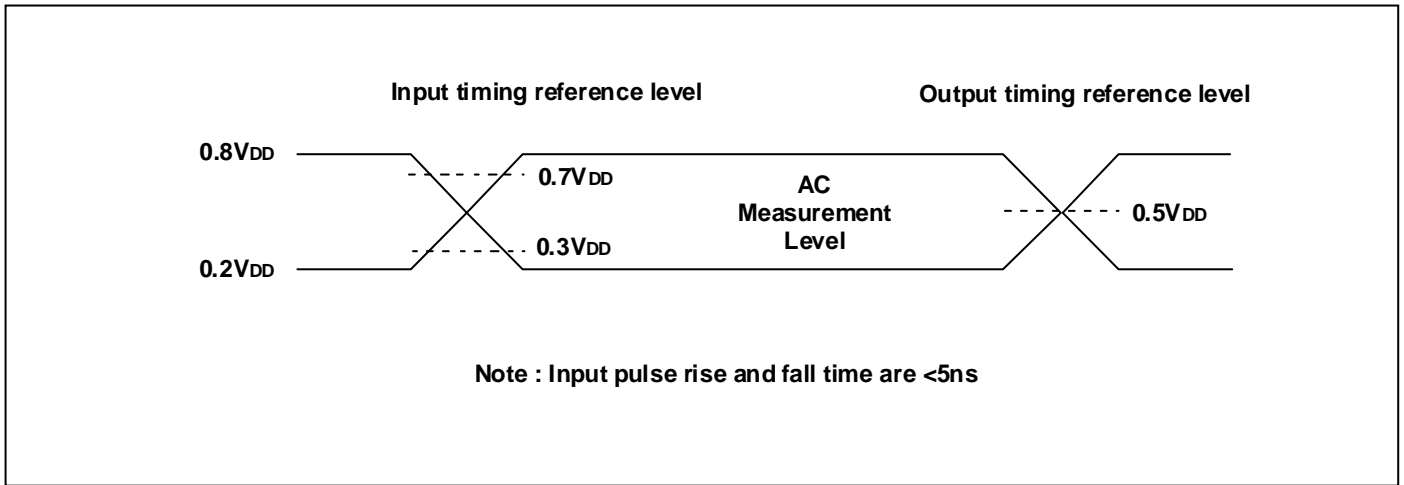

Figure 36: AC Input/Output Reference Waveforms

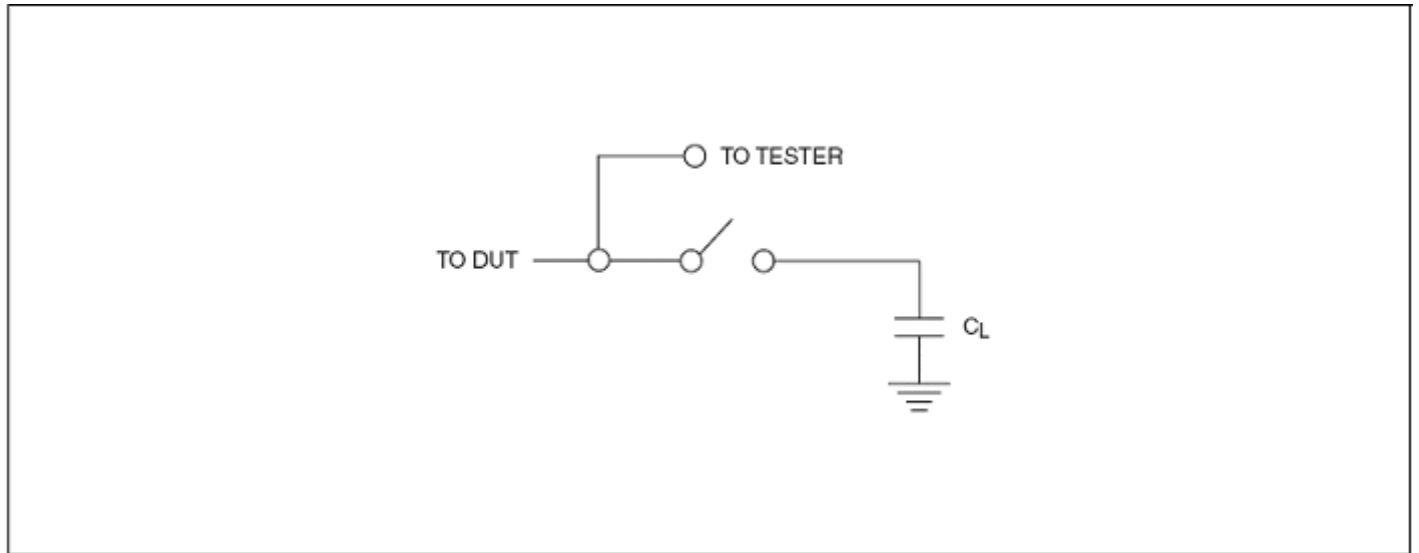
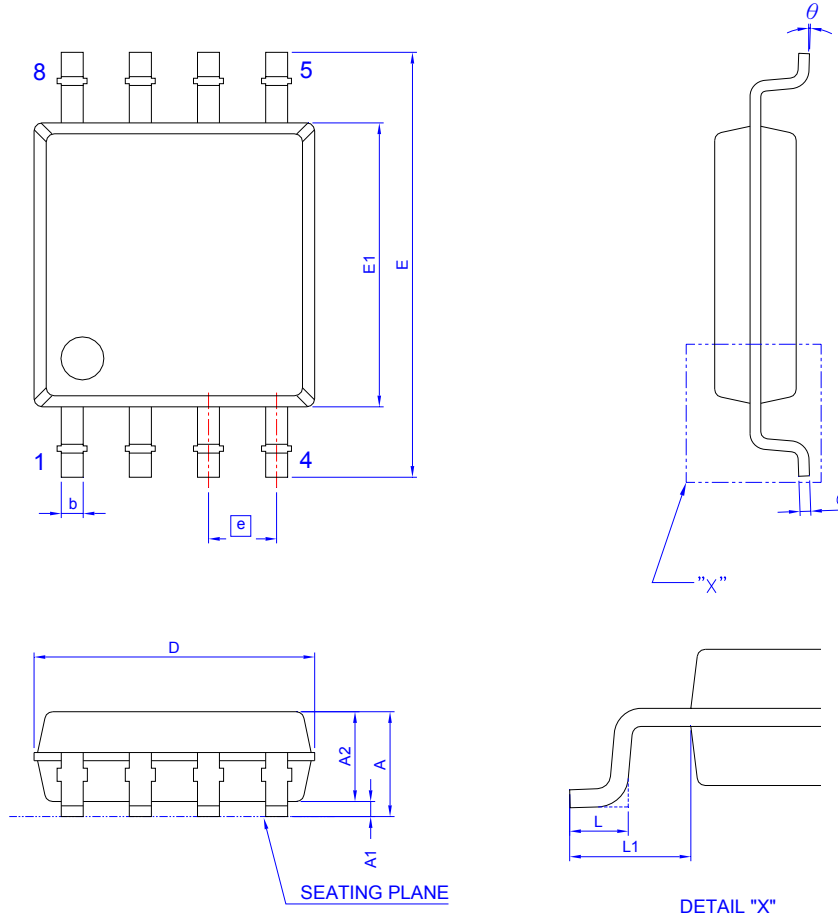

Figure 37: A Test Load Example

PACKING DIMENSIONS

8-LEAD SOIC 200 mil (official name – 208 mil)



Symbol	Dimension in mm			Dimension in inch			Symbol	Dimension in mm			Dimension in inch		
	Min	Norm	Max	Min	Norm	Max		Min	Norm	Max	Min	Norm	Max
A	---	---	2.16	---	---	0.085	E	7.70	7.90	8.10	0.303	0.311	0.319
A ₁	0.05	0.15	0.25	0.002	0.006	0.010	E ₁	5.18	5.28	5.38	0.204	0.208	0.212
A ₂	1.70	1.80	1.91	0.067	0.071	0.075	L	0.50	0.65	0.80	0.020	0.026	0.032
b	0.36	0.41	0.51	0.014	0.016	0.020	e	1.27 BSC			0.050 BSC		
c	0.19	0.20	0.25	0.007	0.008	0.010	L ₁	1.27	1.37	1.47	0.050	0.054	0.058
D	5.13	5.23	5.33	0.202	0.206	0.210	θ	0°	---	8°	0°	---	8°

Controlling dimension : millimeter

PACKING DIMENSIONS

8-LEAD VSOP 208 mil

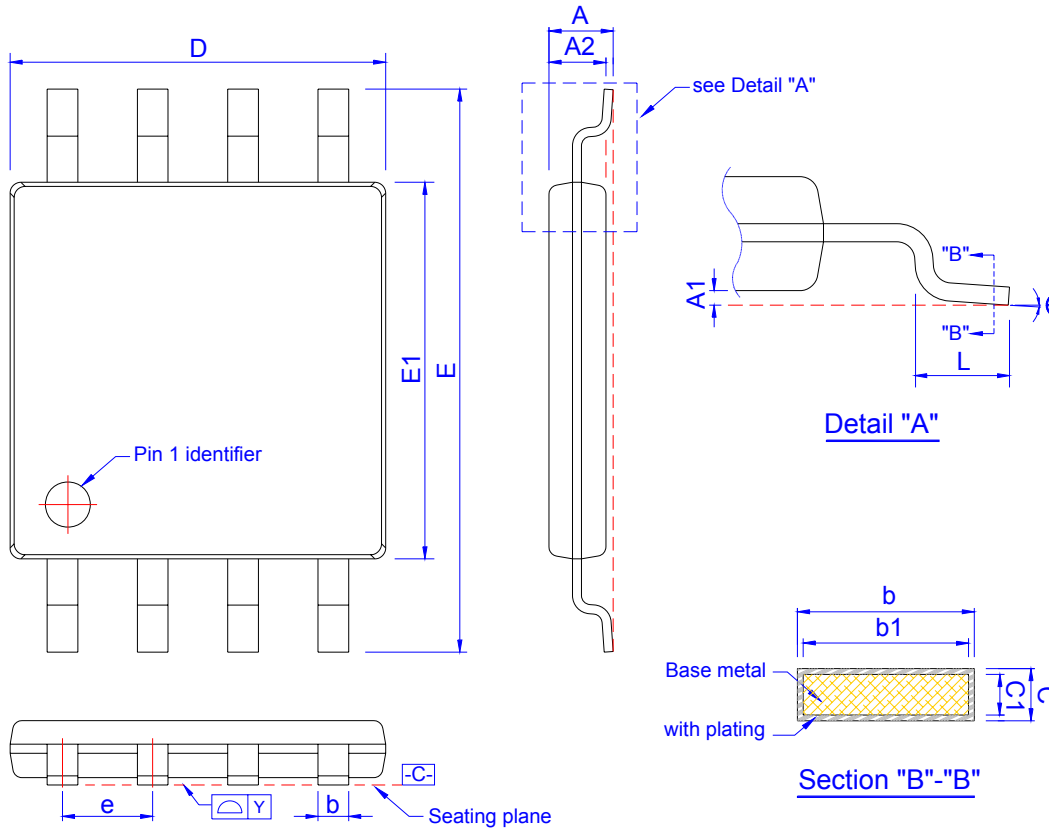

Symbol	Dimension in mm			Dimension in inch		
	Min	Norm	Max	Min	Norm	Max
A	—	—	1.00	—	—	0.039
A1	0.05	0.10	0.15	0.002	0.004	0.006
A2	0.75	0.80	0.85	0.030	0.031	0.033
b	0.35	0.42	0.48	0.014	0.017	0.019
b1	0.35	—	0.46	0.014	—	0.018
c	0.09	—	0.20	0.004	—	0.008
c1	0.09	0.127	0.16	0.004	0.005	0.006
D	5.18	5.28	5.38	0.204	0.208	0.212
E	7.70	7.90	8.10	0.303	0.311	0.319
E1	5.18	5.28	5.38	0.204	0.208	0.212
L	0.50	0.65	0.80	0.020	0.026	0.031
e	1.27 BSC			0.050 BSC		
Y	—	—	0.10	—	—	0.004
θ	0°	—	8°	0°	—	8°

Controlling dimension : Millimeter

(Revision date : Jul 27 2012)

PACKING DIMENSIONS

8-CONTACT WSON (6x5 mm)

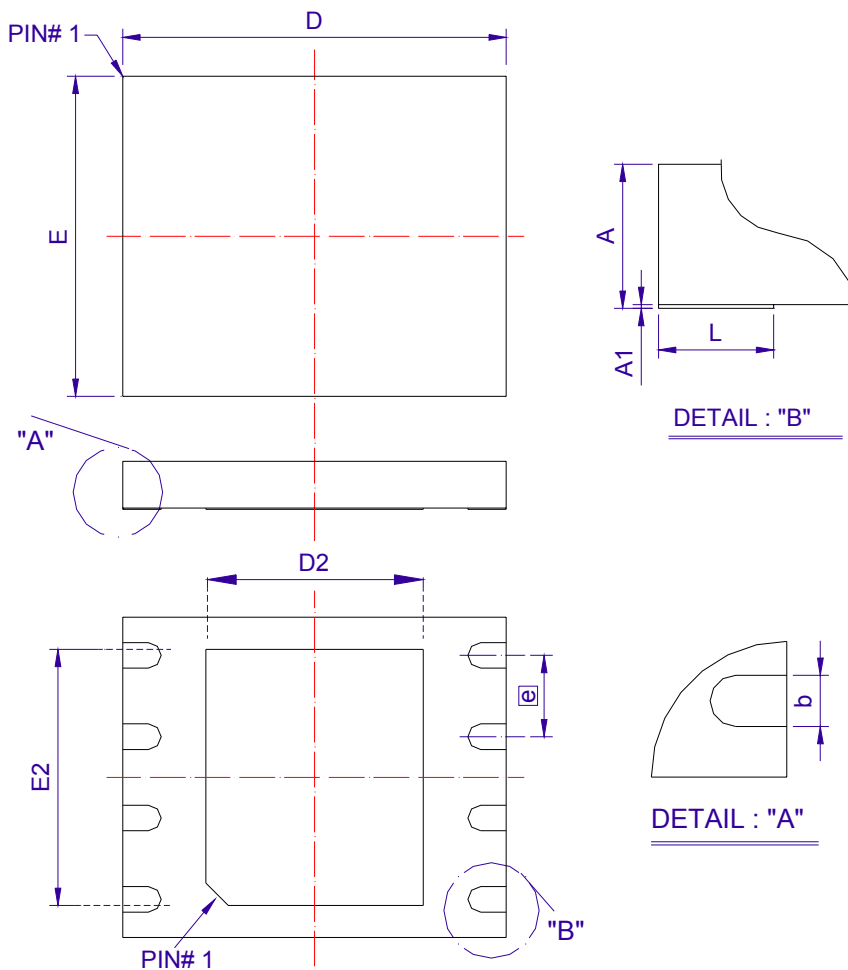

Symbol	Dimension in mm			Dimension in inch		
	Min	Norm	Max	Min	Norm	Max
A	0.70	0.75	0.80	0.028	0.030	0.031
A1	0.00	0.02	0.05	0.000	0.001	0.002
b	0.35	0.40	0.45	0.014	0.016	0.018
D	5.90	6.00	6.10	0.232	0.236	0.240
D2	3.30	3.40	3.50	0.130	0.134	0.138
E	4.90	5.00	5.10	0.193	0.197	0.201
E2	3.90	4.00	4.10	0.154	0.157	0.161
e	1.27 BSC			0.050 BSC		
L	0.55	0.60	0.65	0.022	0.024	0.026

Controlling dimension : millimeter

Revision History

Revision	Date	Description
0.1	2012.08.15	Original
0.2	2012.10.05	<ol style="list-style-type: none">1. Add VSOP package2. Correct the description of Block Protection and Block Protection Lock-Down3. Modify Configuration Register4. Modify the specification of I_{DDW} and T_{RHRL}5. Modify ID Definitions
0.3	2013.01.16	<ol style="list-style-type: none">1. Modify Product ID of VSOP (208mil)2. Correct Block Protection Table

Important Notice

All rights reserved.

No part of this document may be reproduced or duplicated in any form or by any means without the prior permission of ESMT.

The contents contained in this document are believed to be accurate at the time of publication. ESMT assumes no responsibility for any error in this document, and reserves the right to change the products or specification in this document without notice.

The information contained herein is presented only as a guide or examples for the application of our products. No responsibility is assumed by ESMT for any infringement of patents, copyrights, or other intellectual property rights of third parties which may result from its use. No license, either express, implied or otherwise, is granted under any patents, copyrights or other intellectual property rights of ESMT or others.

Any semiconductor devices may have inherently a certain rate of failure. To minimize risks associated with customer's application, adequate design and operating safeguards against injury, damage, or loss from such failure, should be provided by the customer when making application designs.

ESMT's products are not authorized for use in critical applications such as, but not limited to, life support devices or system, where failure or abnormal operation may directly affect human lives or cause physical injury or property damage. If products described here are to be used for such kinds of application, purchaser must do its own quality assurance testing appropriate to such applications.