

Flash

16 Mbit Serial Flash Memory with Dual

■ FEATURES

- Single supply voltage 2.7~3.6V
- Standard and Dual
- Speed
 - Read max frequency: 50MHz
 - Fast Read max frequency: 50MHz / 86MHz / 100MHz
 - Fast Read Dual max frequency: 50MHz / 86MHz / 100MHz (100MHz / 172MHz / 200MHz equivalent Dual SPI)
- Low power consumption
 - Active current: 23.5 mA (max.)
 - Standby current: 25 μ A (max.)
 - Deep Power Down current: 10 μ A (max.)
- Reliability
 - 100,000 typical program/erase cycles
 - 20 years Data Retention
- Program
 - Page programming time: 1.5 ms (typical)
- Erase
 - Chip Erase time 10 sec (typical)
 - 64K bytes Block Erase time 1 sec (typical)
 - 32K bytes Block Erase time 500 ms (typical)
 - 4K bytes Sector Erase time 120 ms (typical)
- Page Programming
 - 256 byte per programmable page
- Lockable 512 bytes OTP security sector
- SPI Serial Interface
 - SPI Compatible: Mode 0 and Mode 3
- End of program or erase detection
- Write Protect (\overline{WP})
- Hold Pin (\overline{HOLD})
- All Pb-free products are RoHS-Compliant

■ ORDERING INFORMATION

Product ID	Speed	Package		Comments
F25L16PA-50PG2S	50MHz	8-lead SOIC	150 mil	Pb-free
F25L16PA-86PG2S	86MHz			
F25L16PA-100PG2S	100MHz			
F25L16PA-50PAG2S	50MHz	8-lead SOIC	200 mil	Pb-free
F25L16PA-86PAG2S	86MHz			
F25L16PA-100PAG2S	100MHz			
F25L16PA-50PHG2S	50MHz	16-lead SOIC	300 mil	Pb-free
F25L16PA-86PHG2S	86MHz			
F25L16PA-100PHG2S	100MHz			
F25L16PA-50DG2S	50MHz	8-pin PDIP	300 mil	Pb-free
F25L16PA-86DG2S	86MHz			
F25L16PA-100DG2S	100MHz			
F25L16PA-50HG2S	50MHz	8-contact WSON	6x5 mm	Pb-free
F25L16PA-86HG2S	86MHz			
F25L16PA-100HG2S	100MHz			

■ GENERAL DESCRIPTION

The F25L16PA is a 16Megabit, 3V only CMOS Serial Flash memory device. The device supports the standard Serial Peripheral Interface (SPI), and a Dual SPI. ESMT's memory devices reliably store memory data even after 100,000 programming and erase cycles.

The memory array can be organized into 8,192 programmable pages of 256 byte each. 1 to 256 byte can be programmed at a time with the Page Program instruction.

The device features sector erase architecture. The memory array

is divided into 512 uniform sectors with 4K byte each; 64 uniform blocks with 32K byte each; 32 uniform blocks with 64K byte each. Sectors can be erased individually without affecting the data in other sectors. Blocks can be erased individually without affecting the data in other blocks. Whole chip erase capabilities provide the flexibility to revise the data in the device. The device has Sector, Block or Chip Erase but no page erase.

The sector protect/unprotect feature disables both program and erase operations in any combination of the sectors of the memory.

■ FUNCTIONAL BLOCK DIAGRAM

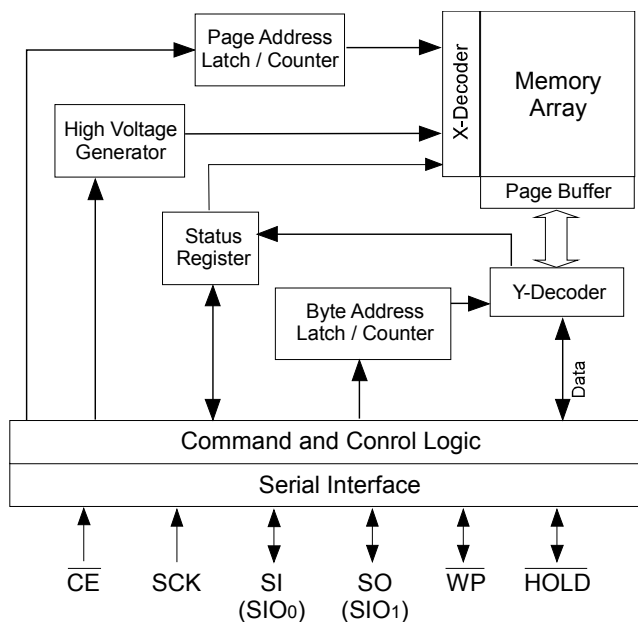

■ PIN CONFIGURATIONS

8-Lead SOIC

(SOIC 8L, 150mil Body, 1.27mm Pin Pitch)

(SOIC 8L, 208mil Body, 1.27mm Pin Pitch)

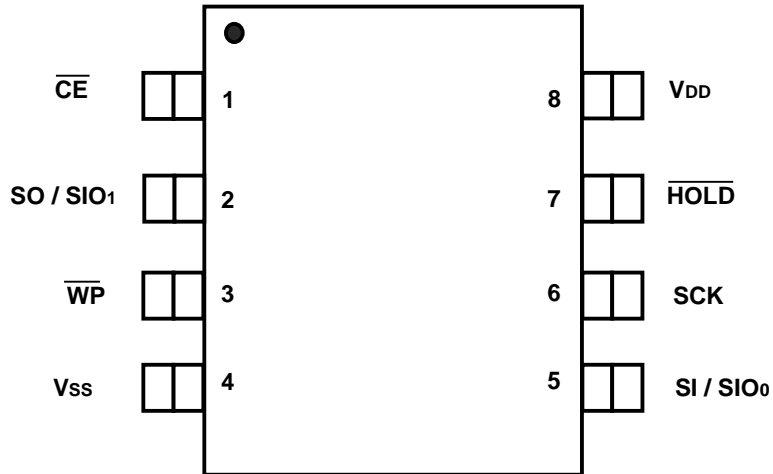

16-Lead SOIC

(SOIC 16L, 300mil Body, 1.27mm Pin Pitch)

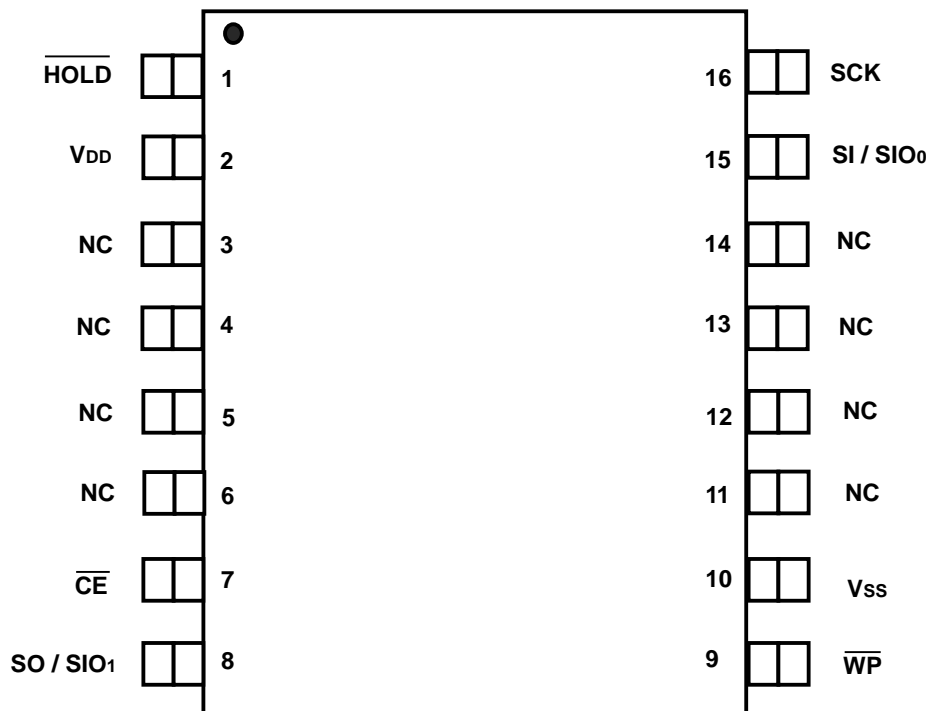

8-Pin PDIP

(PDIP 8P, 300mil Body, 2.54mm Pin Pitch)

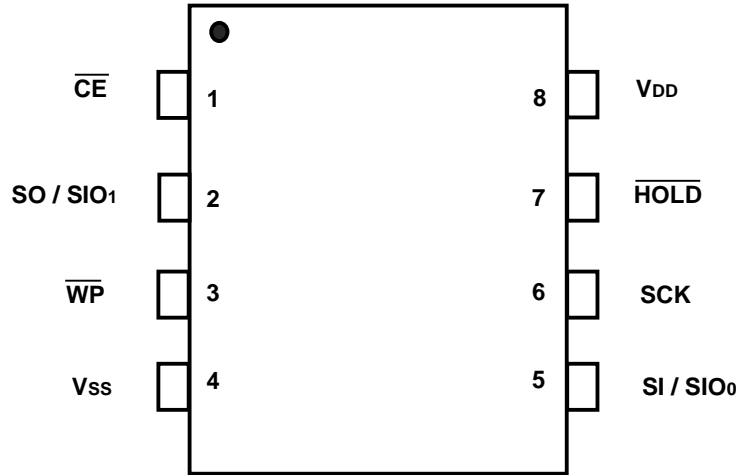

8- Contact WSON

(WSON 8C, 6mmX5mm Body, 1.27mm Contact Pitch)

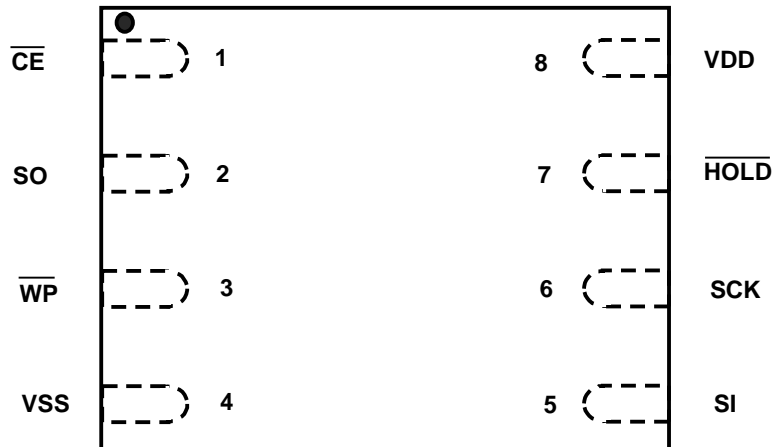

■ PIN DESCRIPTION

Symbol	Pin Name	Functions
SCK	Serial Clock	To provide the timing for serial input and output operations
SI / SIO ₀	Serial Data Input / Serial Data Input Output 0	To transfer commands, addresses or data serially into the device. Data is latched on the rising edge of SCK (for Standard read mode). / Bidirectional IO pin to transfer commands, addresses or data serially into the device on the rising edge of SCK and read data or status from the device on the falling edge of SCK(for Dual mode).
SO / SIO ₁	Serial Data Output / Serial Data Input Output 1	To transfer data serially out of the device. Data is shifted out on the falling edge of SCK (for Standard read mode). / Bidirectional IO pin to transfer commands, addresses or data serially into the device on the rising edge of SCK and read data or status from the device on the falling edge of SCK (for Dual mode).
$\overline{\text{CE}}$	Chip Enable	To activate the device when $\overline{\text{CE}}$ is low.
$\overline{\text{WP}}$	Write Protect	The Write Protect ($\overline{\text{WP}}$) pin is used to enable/disable BPL bit in the status register.
$\overline{\text{HOLD}}$	Hold	To temporality stop serial communication with SPI flash memory without resetting the device.
V _{DD}	Power Supply	To provide power.
V _{SS}	Ground	

■ SECTOR STRUCTURE

Table 1: F25L16PA Sector Address Table

64KB Block	32KB Block	Sector	Sector Size (Kbytes)	Address range	Block Address				
					A20	A19	A18	A17	A16
31	63	511	4KB	1FF000H – 1FFFFFH	1	1	1	1	1
		:	:	:					
		504	4KB	1F8000H – 1F8FFFH					
	62	503	4KB	1F7000H – 1F7FFFH					
		:	:	:					
496	4KB	1F0000H – 1F0FFFH							
30	61	495	4KB	1EF000H – 1EFFFFH	1	1	1	1	0
		:	:	:					
		488	4KB	1E8000H – 1E8FFFH					
	60	487	4KB	1E7000H – 1E7FFFH					
		:	:	:					
480	4KB	1E0000H – 1E0FFFH							
29	59	479	4KB	1DF000H – 1DFFFFH	1	1	1	0	1
		:	:	:					
		472	4KB	1D8000H – 1D8FFFH					
	58	471	4KB	1D7000H – 1D7FFFH					
		:	:	:					
464	4KB	1D0000H – 1D0FFFH							
28	57	463	4KB	1CF000H – 1CFFFFH	1	1	1	0	0
		:	:	:					
		456	4KB	1C8000H – 1C8FFFH					
	56	455	4KB	1C7000H – 1C7FFFH					
		:	:	:					
448	4KB	1C0000H – 1C0FFFH							
27	55	447	4KB	1BF000H – 1BFFFFH	1	1	0	1	1
		:	:	:					
		440	4KB	1B8000H – 1B8FFFH					
	54	439	4KB	1B7000H – 1B7FFFH					
		:	:	:					
432	4KB	1B0000H – 1B0FFFH							
26	53	431	4KB	1AF000H – 1AFFFFH	1	1	0	1	0
		:	:	:					
		424	4KB	1A8000H – 1A8FFFH					
	52	423	4KB	1A7000H – 1A7FFFH					
		:	:	:					
416	4KB	1A0000H – 1A0FFFH							

Table 1: F25L16PA Sector Address Table – Continued I

64KB Block	32KB Block	Sector	Sector Size (Kbytes)	Address range	Block Address				
					A20	A19	A18	A17	A16
25	51	415	4KB	19F000H – 19FFFFH	1	1	0	0	1
		:	:	:					
	408	4KB	198000H – 198FFFH						
	50	407	4KB	197000H – 197FFFH					
		:	:	:					
400	4KB	190000H – 190FFFH							
24	49	399	4KB	18F000H – 18FFFFH	1	1	0	0	0
		:	:	:					
	392	4KB	188000H – 188FFFH						
	48	391	4KB	187000H – 187FFFH					
		:	:	:					
384	4KB	180000H – 180FFFH							
23	47	383	4KB	17F000H – 17FFFFH	1	0	1	1	1
		:	:	:					
	376	4KB	178000H – 178FFFH						
	46	375	4KB	177000H – 177FFFH					
		:	:	:					
368	4KB	170000H – 170FFFH							
22	45	367	4KB	16F000H – 16FFFFH	1	0	1	1	0
		:	:	:					
	360	4KB	168000H – 168FFFH						
	44	359	4KB	167000H – 167FFFH					
		:	:	:					
352	4KB	160000H – 160FFFH							
21	43	351	4KB	15F000H – 15FFFFH	1	0	1	0	1
		:	:	:					
	344	4KB	158000H – 158FFFH						
	42	343	4KB	157000H – 157FFFH					
		:	:	:					
336	4KB	150000H – 150FFFH							
20	41	335	4KB	14F000H – 14FFFFH	1	0	1	0	0
		:	:	:					
	328	4KB	148000H – 148FFFH						
	40	327	4KB	147000H – 147FFFH					
		:	:	:					
320	4KB	140000H – 140FFFH							
19	39	319	4KB	13F000H – 13FFFFH	1	0	0	1	1
		:	:	:					
	312	4KB	138000H – 138FFFH						
	38	311	4KB	137000H – 137FFFH					
		:	:	:					
304	4KB	130000H – 130FFFH							

Table 1: F25L16PA Sector Address Table – Continued II

64KB Block	32KB Block	Sector	Sector Size (Kbytes)	Address range	Block Address				
					A20	A19	A18	A17	A16
18	37	303	4KB	12F000H – 12FFFFH	1	0	0	1	0
		:	:	:					
	296	4KB	128000H – 128FFFH						
	36	295	4KB	127000H – 127FFFH					
		:	:	:					
288	4KB	120000H – 120FFFH							
17	35	287	4KB	11F000H – 11FFFFH	1	0	0	0	1
		:	:	:					
	280	4KB	118000H – 118FFFH						
	34	279	4KB	117000H – 117FFFH					
		:	:	:					
272	4KB	110000H – 110FFFH							
16	33	271	4KB	10F000H – 10FFFFH	1	0	0	0	0
		:	:	:					
	264	4KB	108000H – 108FFFH						
	32	263	4KB	107000H – 107FFFH					
		:	:	:					
256	4KB	100000H – 100FFFH							
15	31	255	4KB	0FF000H – 0FFFFFFH	0	1	1	1	1
		:	:	:					
	248	4KB	0F8000H – 0F8FFFH						
	30	247	4KB	0F7000H – 0F7FFFH					
		:	:	:					
240	4KB	0F0000H – 0F0FFFH							
14	29	239	4KB	0EF000H – 0EFFFFH	0	1	1	1	0
		:	:	:					
	232	4KB	0E8000H – 0E8FFFH						
	28	231	4KB	0E7000H – 0E7FFFH					
		:	:	:					
224	4KB	0E0000H – 0E0FFFH							
13	27	223	4KB	0DF000H – 0DFFFFH	0	1	1	0	1
		:	:	:					
	216	4KB	0D8000H – 0D8FFFH						
	26	215	4KB	0D7000H – 0D7FFFH					
		:	:	:					
208	4KB	0D0000H – 0D0FFFH							
12	25	207	4KB	0CF000H – 0CFFFFH	0	1	1	0	0
		:	:	:					
	200	4KB	0C8000H – 0C8FFFH						
	24	199	4KB	0C7000H – 0C7FFFH					
		:	:	:					
192	4KB	0C0000H – 0C0FFFH							

Table 1: F25L16PA Sector Address Table – Continued III

64KB Block	32KB Block	Sector	Sector Size (Kbytes)	Address range	Block Address				
					A20	A19	A18	A17	A16
11	23	191	4KB	0BF000H – 0BFFFFH	0	1	0	1	1
		:	:	:					
		184	4KB	0B8000H – 0B8FFFH					
	22	183	4KB	0B7000H – 0B7FFFH					
		:	:	:					
	176	4KB	0B0000H – 0B0FFFH						
10	21	175	4KB	0AF000H – 0AFFFFH	0	1	0	1	0
		:	:	:					
		168	4KB	0A8000H – 0A8FFFH					
	20	167	4KB	0A7000H – 0A7FFFH					
		:	:	:					
	160	4KB	0A0000H – 0A0FFFH						
9	19	159	4KB	09F000H – 09FFFFH	0	1	0	0	1
		:	:	:					
		152	4KB	098000H – 098FFFH					
	18	151	4KB	097000H – 097FFFH					
		:	:	:					
	144	4KB	090000H – 090FFFH						
8	17	143	4KB	08F000H – 08FFFFH	0	1	0	0	0
		:	:	:					
		136	4KB	088000H – 088FFFH					
	16	135	4KB	087000H – 087FFFH					
		:	:	:					
	128	4KB	080000H – 080FFFH						
7	15	127	4KB	07F000H – 07FFFFH	0	0	1	1	1
		:	:	:					
		120	4KB	078000H – 078FFFH					
	14	119	4KB	077000H – 077FFFH					
		:	:	:					
	112	4KB	070000H – 070FFFH						
6	13	111	4KB	06F000H – 06FFFFH	0	0	1	1	0
		:	:	:					
		104	4KB	068000H – 068FFFH					
	12	103	4KB	067000H – 067FFFH					
		:	:	:					
	96	4KB	060000H – 060FFFH						
5	11	95	4KB	05F000H – 05FFFFH	0	0	1	0	1
		:	:	:					
		88	4KB	058000H – 058FFFH					
	10	87	4KB	057000H – 057FFFH					
		:	:	:					
	80	4KB	050000H – 050FFFH						

Table 1: F25L16PA Sector Address Table – Continued IV

64KB Block	32KB Block	Sector	Sector Size (Kbytes)	Address range	Block Address				
					A20	A19	A18	A17	A16
4	9	79	4KB	04F000H – 04FFFFH	0	0	1	0	0
		:	:	:					
		72	4KB	048000H – 048FFFH					
	8	71	4KB	047000H – 047FFFH					
		:	:	:					
64	4KB	040000H – 040FFFH							
3	7	63	4KB	03F000H – 03FFFFH	0	0	0	1	1
		:	:	:					
		56	4KB	038000H – 038FFFH					
	6	55	4KB	037000H – 037FFFH					
		:	:	:					
48	4KB	030000H – 030FFFH							
2	5	47	4KB	02F000H – 02FFFFH	0	0	0	1	0
		:	:	:					
		40	4KB	028000H – 028FFFH					
	4	39	4KB	027000H – 027FFFH					
		:	:	:					
32	4KB	020000H – 020FFFH							
1	3	31	4KB	01F000H – 01FFFFH	0	0	0	0	1
		:	:	:					
		24	4KB	018000H – 018FFFH					
	2	23	4KB	017000H – 017FFFH					
		:	:	:					
16	4KB	010000H – 010FFFH							
0	1	15	4KB	00F000H – 00FFFFH	0	0	0	0	0
		:	:	:					
		8	4KB	008000H – 008FFFH					
	0	7	4KB	007000H – 007FFFH					
		:	:	:					
0	4KB	000000H – 000FFFH							

■ STATUS REGISTER

The software status register provides status on whether the flash memory array is available for any Read or Write operation, whether the device is Write enabled, and the state of the memory Write protection. During an internal Erase or Program operation,

the status register may be read only to determine the completion of an operation in progress. Table 2 describes the function of each bit in the software status register.

Table 2: Software Status Register

Bit	Name	Function	Default at Power-up	Read/Write
Status Register				
0	BUSY	1 = Internal Write operation is in progress 0 = No internal Write operation is in progress	0	R
1	WEL	1 = Device is memory Write enabled 0 = Device is not memory Write enabled	0	R
2	BP0	Indicate current level of block write protection (See Table 3)	0	R/W
3	BP1	Indicate current level of block write protection (See Table 3)	0	R/W
4	BP2	Indicate current level of block write protection (See Table 3)	0	R/W
5	BP3	Indicate current level of block write protection (See Table 3)	0	R/W
6	RESERVED	Reserved for future use	0	N/A
7	BPL	1 = BP3, BP2, BP1, BP0 are read-only bits 0 = BP3, BP2, BP1, BP0 are read/writable	0	R/W

Note:

1. BUSY and WEL are read only.
2. BP0~3 and BPL bits are non-volatile.

Write Enable Latch (WEL)

The Write-Enable-Latch bit indicates the status of the internal memory Write Enable Latch. If this bit is set to "1", it indicates the device is Write enabled. If the bit is set to "0" (reset), it indicates the device is not Write enabled and does not accept any memory Write (Program/ Erase) commands. This bit is automatically reset under the following conditions:

- Power-up
- Write Disable (WRDI) instruction completion
- Page Program instruction completion
- Sector Erase instruction completion
- Block Erase instruction completion
- Chip Erase instruction completion
- Write Status Register instructions

BUSY

The BUSY bit determines whether there is an internal Erase or Program operation in progress. A "1" for the BUSY bit indicates the device is busy with an operation in progress. A "0" indicates the device is ready for the next valid operation.

Table 3: F25L16PA Block Protection Table

Protection Level	Status Register Bit				Protected Memory Area	
	BP3	BP2	BP1	BP0	Block Range	Address Range
0	0	0	0	0	None	None
Upper 1/32	0	0	0	1	Block 31	1F0000H – 1FFFFFFH
Upper 1/16	0	0	1	0	Block 30~31	1E0000H – 1FFFFFFH
Upper 1/8	0	0	1	1	Block 28~31	1C0000H – 1FFFFFFH
Upper 1/4	0	1	0	0	Block 24~31	180000H – 1FFFFFFH
Upper 1/2	0	1	0	1	Block 16~31	100000H – 1FFFFFFH
All Blocks	0	1	1	0	Block 0~31	000000H – 1FFFFFFH
All Blocks	0	1	1	1	Block 0~31	000000H – 1FFFFFFH
All Blocks	1	0	0	0	Block 0~31	000000H – 1FFFFFFH
All Blocks	1	0	0	1	Block 0~31	000000H – 1FFFFFFH
Bottom 1/2	1	0	1	0	Block 0~15	000000H – 0FFFFFFH
Bottom 3/4	1	0	1	1	Block 0~23	000000H – 17FFFFFFH
Bottom 7/8	1	1	0	0	Block 0~27	000000H – 1BFFFFFFH
Bottom 15/16	1	1	0	1	Block 0~29	000000H – 1DFFFFFFH
Bottom 31/32	1	1	1	0	Block 0~30	000000H – 1EFFFFFFH
All Blocks	1	1	1	1	Block 0~31	000000H – 1FFFFFFH

Block Protection (BP3, BP2, BP1, BP0)

The Block-Protection (BP3, BP2, BP1, BP0) bits define the memory area, as defined in Table 3, to be software protected against any memory Write (Program or Erase) operations. The Write Status Register (WRSR) instruction is used to program the BP3, BP2, BP1 and BP0 bits as long as \overline{WP} is high or the Block-Protection-Look (BPL) bit is 0. Chip Erase can only be executed if BP3, BP2, BP1 and BP0 bits are all 0. The factory default setting for Block Protection Bit (BP3 ~ BP0) is 0.

Block Protection Lock-Down (BPL)

\overline{WP} pin driven low (V_{IL}), enables the Block-Protection-Lock-Down (BPL) bit. When BPL is set to 1, it prevents any further alteration of the BPL, BP3, BP2, BP1 and BP0 bits. When the \overline{WP} pin is driven high (V_{IH}), the BPL bit has no effect and its value is "Don't Care".

■ HOLD OPERATION

$\overline{\text{HOLD}}$ pin is used to pause a serial sequence underway with the SPI flash memory without resetting the clocking sequence. To activate the $\overline{\text{HOLD}}$ mode, $\overline{\text{CE}}$ must be in active low state. The $\overline{\text{HOLD}}$ mode begins when the SCK active low state coincides with the falling edge of the $\overline{\text{HOLD}}$ signal. The HOLD mode ends when the $\overline{\text{HOLD}}$ signal's rising edge coincides with the SCK active low state.

If the falling edge of the $\overline{\text{HOLD}}$ signal does not coincide with the SCK active low state, then the device enters Hold mode when the SCK next reaches the active low state.

Similarly, if the rising edge of the $\overline{\text{HOLD}}$ signal does not coincide with the SCK active low state, then the device exits in Hold mode when the SCK next reaches the active low state. See

Figure 1 for Hold Condition waveform.

Once the device enters Hold mode, SO will be in high impedance state while SI and SCK can be V_{IL} or V_{IH} .

If $\overline{\text{CE}}$ is driven active high during a Hold condition, it resets the internal logic of the device. As long as $\overline{\text{HOLD}}$ signal is low, the memory remains in the Hold condition. To resume communication with the device, $\overline{\text{HOLD}}$ must be driven active high, and $\overline{\text{CE}}$ must be driven active low. See Figure 27 for Hold timing.

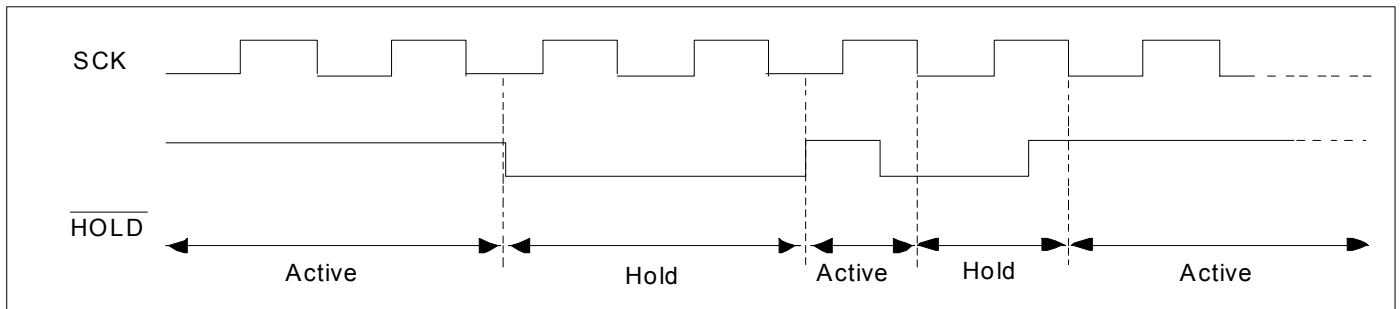

Figure 1: HOLD Condition Waveform

■ WRITE PROTECTION

The device provides software Write Protection.

The Write-Protect pin ($\overline{\text{WP}}$) enables or disables the lock-down function of the status register. The Block-Protection bits (BP3, BP2, BP1, BP0 and BPL) in the status register provide Write protection to the memory array and the status register.

Write Protect Pin ($\overline{\text{WP}}$)

The Write-Protect ($\overline{\text{WP}}$) pin enables the lock-down function of the BPL bit (bit 7) in the status register. When $\overline{\text{WP}}$ is driven low, the execution of the Write Status Register (WRSR) instruction is determined by the value of the BPL bit (see Table 4). When $\overline{\text{WP}}$ is high, the lock-down function of the BPL bit is disabled.

Table 4: Conditions to Execute Write-Status- Register (WRSR) Instruction

$\overline{\text{WP}}$	BPL	Execute WRSR Instruction
L	1	Not Allowed
L	0	Allowed
H	X	Allowed

■ INSTRUCTIONS

Instructions are used to Read, Write (Erase and Program), and configure the F25L16PA. The instruction bus cycles are 8 bits each for commands (Op Code), data, and addresses. Prior to executing any Page Program, Write Status Register, Sector Erase, Block Erase, or Chip Erase instructions, the Write Enable (WREN) instruction must be executed first. The complete list of the instructions is provided in Table 5. All instructions are synchronized off a high to low transition of \overline{CE} . Inputs will be accepted on the rising edge of SCK starting with the most significant bit. \overline{CE} must be driven low before an instruction is

entered and must be driven high after the last bit of the instruction has been shifted in (except for Read, Read ID, Read Status Register, Read Electronic Signature instructions). Any low to high transition on \overline{CE} , before receiving the last bit of an instruction bus cycle, will terminate the instruction in progress and return the device to the standby mode.

Instruction commands (Op Code), addresses, and data are all input from the most significant bit (MSB) first.

Table 5: Device Operation Instruction

Operation	Max. Freq	Bus Cycle ¹⁻³													
		1		2		3		4		5		6		N	
		S _{IN}	S _{OUT}	S _{IN}	S _{OUT}	S _{IN}	S _{OUT}	S _{IN}	S _{OUT}	S _{IN}	S _{OUT}	S _{IN}	S _{OUT}	S _{IN}	S _{OUT}
Read	50 MHz	03H	Hi-Z	A ₂₃ -A ₁₆	Hi-Z	A ₁₅ -A ₈	Hi-Z	A ₇ -A ₀	Hi-Z	X	D _{OUT0}	X	D _{OUT1}	X	cont.
Fast Read		0BH	Hi-Z	A ₂₃ -A ₁₆	Hi-Z	A ₁₅ -A ₈	Hi-Z	A ₇ -A ₀	Hi-Z	X	X	X	D _{OUT0}	X	cont.
Fast Read Dual Output ^{12,13}		3BH		A ₂₃ -A ₁₆		A ₁₅ -A ₈		A ₇ -A ₀		X		D _{OUT0-1}		cont.	
Fast Read Dual I/O ^{12,14}		BBH		A ₂₃ -A ₈		A ₇ -A ₀ , M ₇ -M ₀		D _{OUT0-1}		cont.		-		-	
Sector Erase ⁴ (4K Byte)		20H	Hi-Z	A ₂₃ -A ₁₆	Hi-Z	A ₁₅ -A ₈	Hi-Z	A ₇ -A ₀	Hi-Z	-	-	-	-	-	-
Block Erase ⁵ (32K Byte)		52H	Hi-Z	A ₂₃ -A ₁₆	Hi-Z	A ₁₅ -A ₈	Hi-Z	A ₇ -A ₀	Hi-Z	-	-	-	-	-	-
Block Erase ⁵ (64K Byte)		D8H	Hi-Z	A ₂₃ -A ₁₆	Hi-Z	A ₁₅ -A ₈	Hi-Z	A ₇ -A ₀	Hi-Z	-	-	-	-	-	-
Chip Erase		60H / C7H	Hi-Z	-	-	-	-	-	-	-	-	-	-	-	-
Erase Suspend		75H	Hi-Z	-	-	-	-	-	-	-	-	-	-	-	-
Erase Resume		7AH	Hi-Z	-	-	-	-	-	-	-	-	-	-	-	-
Page Program (PP) ⁶	50MHz	02H	Hi-Z	A ₂₃ -A ₁₆	Hi-Z	A ₁₅ -A ₈	Hi-Z	A ₇ -A ₀	Hi-Z	D _{IN0}	Hi-Z	D _{IN1}	Hi-Z	Up to 256 bytes	Hi-Z
Mode Bit Reset ¹⁵		FFH	Hi-Z	FFH	Hi-Z	-	-	-	-	-	-	-	-	-	-
Deep Power Down (DP)		B9h	Hi-Z	-	-	-	-	-	-	-	-	-	-	-	-
Read Status Register (RDSR) ⁷	~	05H	Hi-Z	X	D _{OUT} (S ₇ -S ₀)	-	-	-	-	-	-	-	-	-	-
Write Status Register (WRSR) ¹⁰		01H	Hi-Z	D _{IN} (S ₇ -S ₀)	Hi-Z	-	-	-	-	-	-	-	-	-	-
Write Enable (WREN) ¹⁰	100MHz	06H	Hi-Z	-	-	-	-	-	-	-	-	-	-	-	-
Write Disable (WRDI)/ Exit secured OTP mode		04H	Hi-Z	-	-	-	-	-	-	-	-	-	-	-	-
Enter secured OTP mode (ENSO)		B1H	Hi-Z	-	-	-	-	-	-	-	-	-	-	-	-
Release from Deep Power Down (RDP)		ABH	Hi-Z	-	-	-	-	-	-	-	-	-	-	-	-
Read Electronic Signature (RES) ⁸		ABH	Hi-Z	X	X	X	X	X	X	X	14H	-	-	-	-
RES in secured OTP mode & not lock down		ABH	Hi-Z	X	X	X	X	X	X	X	34H	-	-	-	-
RES in secured OTP mode & lock down		ABH	Hi-Z	X	X	X	X	X	X	X	74H	-	-	-	-

Table 5: Device Operation Instruction - Continued

Operation	Max. Freq	Bus Cycle ¹⁻³													
		1		2		3		4		5		6		N	
		S _{IN}	S _{OUT}	S _{IN}	S _{OUT}	S _{IN}	S _{OUT}	S _{IN}	S _{OUT}	S _{IN}	S _{OUT}	S _{IN}	S _{OUT}	S _{IN}	S _{OUT}
Jedec Read ID (JEDEC-ID) ⁹	50MHz	9FH	Hi-Z	X	8CH	X	21H	X	15H	-	-	-	-	-	-
Read ID (RDID) ¹¹	100MHz	90H	Hi-Z	00H	Hi-Z	00H	Hi-Z	00H	Hi-Z	X	8CH	X	14H	-	-
								01H	Hi-Z	X	14H	X	8CH	-	-

Notes:

1. Operation: S_{IN} = Serial In, S_{OUT} = Serial Out, Bus Cycle 1 = Op Code
2. X = Dummy Input Cycles (V_{IL} or V_{IH}); - = Non-Applicable Cycles (Cycles are not necessary); cont. = continuous
3. One bus cycle is eight clock periods.
4. 4K byte Sector Erase addresses: use A_{MS} -A₁₂, remaining addresses can be V_{IL} or V_{IH}.
5. 32K byte Block Erase addresses: use A_{MS} -A₁₅, remaining addresses can be V_{IL} or V_{IH}
64K byte Block Erase addresses: use A_{MS} -A₁₆, remaining addresses can be V_{IL} or V_{IH}
6. To continue programming to the next sequential address location, enter the 8-bit command, followed by the data to be programmed.
7. The Read-Status-Register is continuous with ongoing clock cycles until terminated by a low to high transition on \overline{CE} .
8. The Read-Electronic-Signature is continuous with on going clock cycles until terminated by a low to high transition on \overline{CE} .
9. The JEDEC-Read-ID is output first byte 8CH as manufacture ID; second byte 21H as memory type; third byte 15H as memory capacity.
10. The Write-Enable (WREN) instruction and the Write-Status-Register (WRSR) instruction must work in conjunction of each other. The WRSR instruction must be executed immediately (very next bus cycle) after the WREN instruction to make both instructions effective. A successful WRSR can reset WREN.
11. The Manufacture ID and Device ID output will repeat continuously until \overline{CE} terminates the instruction.
12. Dual commands use bidirectional IO pins. D_{OUT} and cont. are serial data out; others are serial data in.
13. Dual output data:
 IO₀ = (D₆, D₄, D₂, D₀), (D₆, D₄, D₂, D₀)
 IO₁ = (D₇, D₅, D₃, D₁), (D₇, D₅, D₃, D₁)
 D_{OUT0} D_{OUT1}
14. M₇-M₀: Mode bits. Dual input address:
 IO₀ = (A₂₂, A₂₀, A₁₈, A₁₆, A₁₄, A₁₂, A₁₀, A₈) (A₆, A₄, A₂, A₀, M₆, M₄, M₂, M₀)
 IO₁ = (A₂₃, A₂₁, A₁₉, A₁₇, A₁₅, A₁₃, A₁₁, A₉) (A₇, A₅, A₃, A₁, M₇, M₅, M₃, M₁)
 Bus Cycle-2 Bus Cycle-3
15. This instruction is recommended when using the Dual Mode bit feature.

Read (50MHz)

The Read instruction supports up to 50 MHz, it outputs the data starting from the specified address location. The data output stream is continuous through all addresses until terminated by a low to high transition on \overline{CE} . The internal address pointer will automatically increment until the highest memory address is reached. Once the highest memory address is reached, the address pointer will automatically increment to the beginning (wrap-around) of the address space, i.e. for 16Mbit density, once

the data from address location 1FFFFFFH had been read, the next output will be from address location 000000H.

The Read instruction is initiated by executing an 8-bit command, 03H, followed by address bits [A₂₃-A₀]. \overline{CE} must remain active low for the duration of the Read cycle. See Figure 2 for the Read sequence.

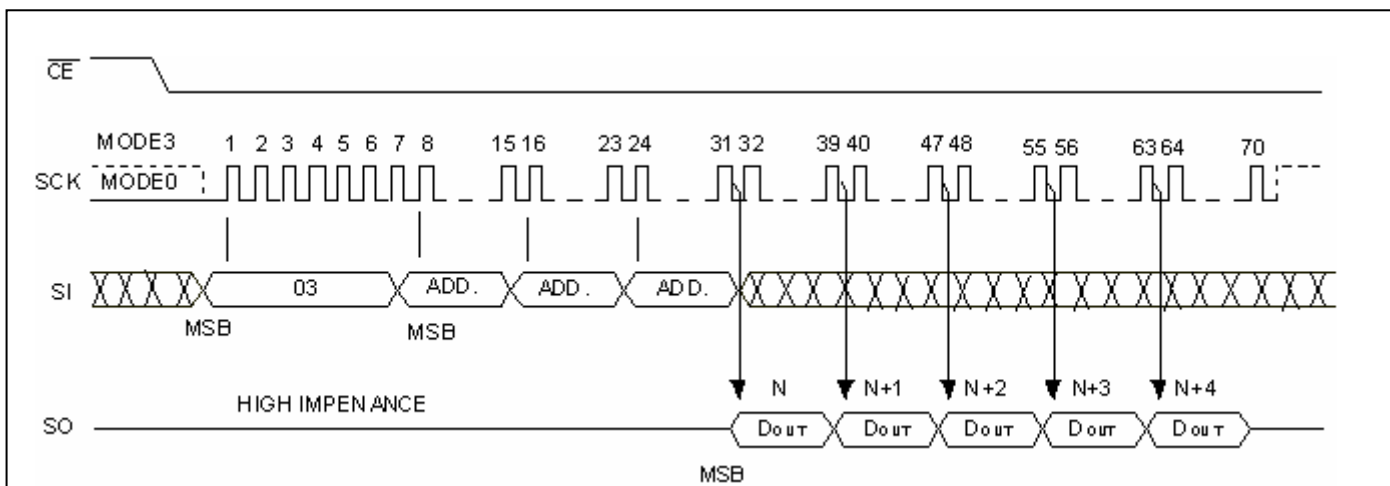

Figure 2: Read Sequence

Fast Read (50 MHz ~ 100 MHz)

The Fast Read instruction supporting up to 100 MHz is initiated by executing an 8-bit command, 0BH, followed by address bits [A₂₃-A₀] and a dummy byte. \overline{CE} must remain active low for the duration of the Fast Read cycle. See Figure 3 for the Fast Read sequence.

all addresses until terminated by a low to high transition on \overline{CE} . The internal address pointer will automatically increment until the highest memory address is reached. Once the highest memory address is reached, the address pointer will automatically increment to the beginning (wrap-around) of the address space, i.e. for 16Mbit density, once the data from address location 1FFFFFFH has been read, the next output will be from address location 000000H.

Following a dummy byte (8 clocks input dummy cycle), the Fast Read instruction outputs the data starting from the specified address location. The data output stream is continuous through

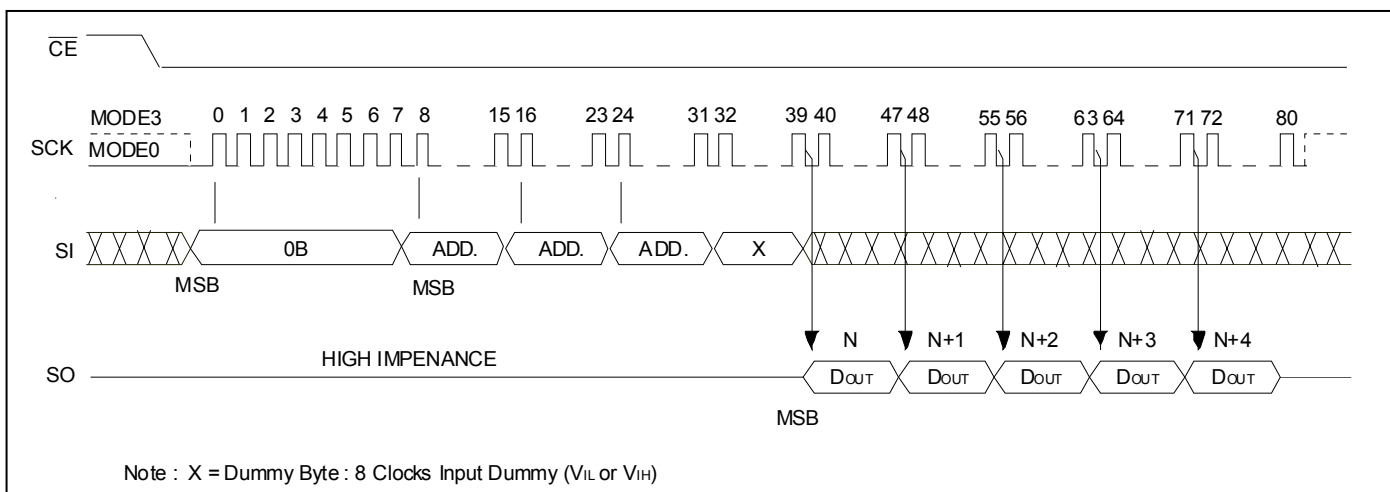

Figure 3: Fast Read Sequence

Fast Read Dual Output (50 MHz ~ 100 MHz)

The Fast Read Dual Output (3BH) instruction is similar to the standard Fast Read (0BH) instruction except the data is output on bidirectional I/O pins (SIO₀ and SIO₁). This allows data to be transferred from the device at twice the rate of standard SPI devices. This instruction is for quickly downloading code from Flash to RAM upon power-up or for applications that cache code-segments to RAM for execution.

The Fast Read Dual Output instruction is initiated by executing an 8-bit command, 3BH, followed by address bits [A₂₃-A₀] and a dummy byte. \overline{CE} must remain active low for the duration of the Fast Read Dual Output cycle. See Figure 4 for the Fast Read Dual Output sequence.

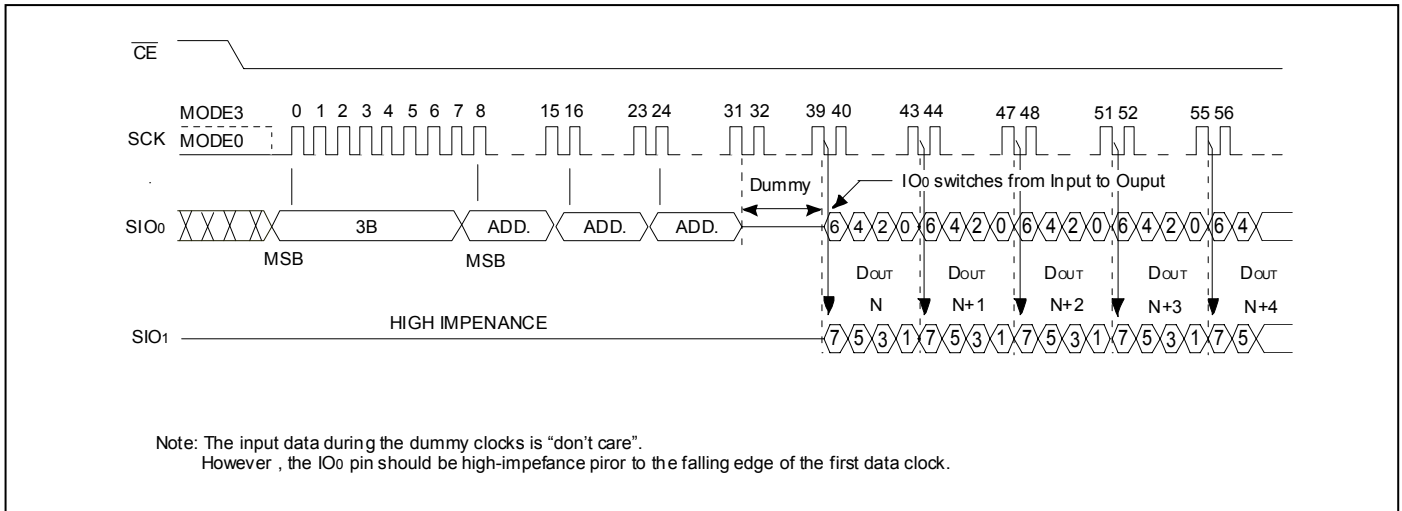

Figure 4: Fast Read Dual Output Sequence

Fast Read Dual I/O (50 MHz ~ 100 MHz)

The Fast Read Dual I/O (BBH) instruction is similar to the Fast Read Dual Output (3BH) instruction, but with the capability to input address bits $[A_{23}-A_0]$ two bits per clock.

To set mode bits $[M_7-M_0]$ after the address bits $[A_{23}-A_0]$ can further reduce instruction overhead (See Figure 5). The upper mode bits $[M_7-M_4]$ controls the length of next Fast Read Dual I/O instruction with/without the first byte command code (BBH). The lower mode bits $[M_3-M_0]$ are "don't care".

If $[M_7-M_0] = \text{"AxH"}$, the next Fast Read Dual I/O instruction (after $\overline{\text{CE}}$ is raised and the lowered) doesn't need the command code (See Figure 6). This way let the instruction sequence reduce 8 clocks and allows to enter address immediately after $\overline{\text{CE}}$ is asserted low. If $[M_7-M_0]$ are the value other than "AxH", the next instruction need the first byte command code, thus returning to normal operation. A Mode Bit Reset (FFH) also can be used to reset mode bits $[M_7-M_0]$ before issuing normal instructions.

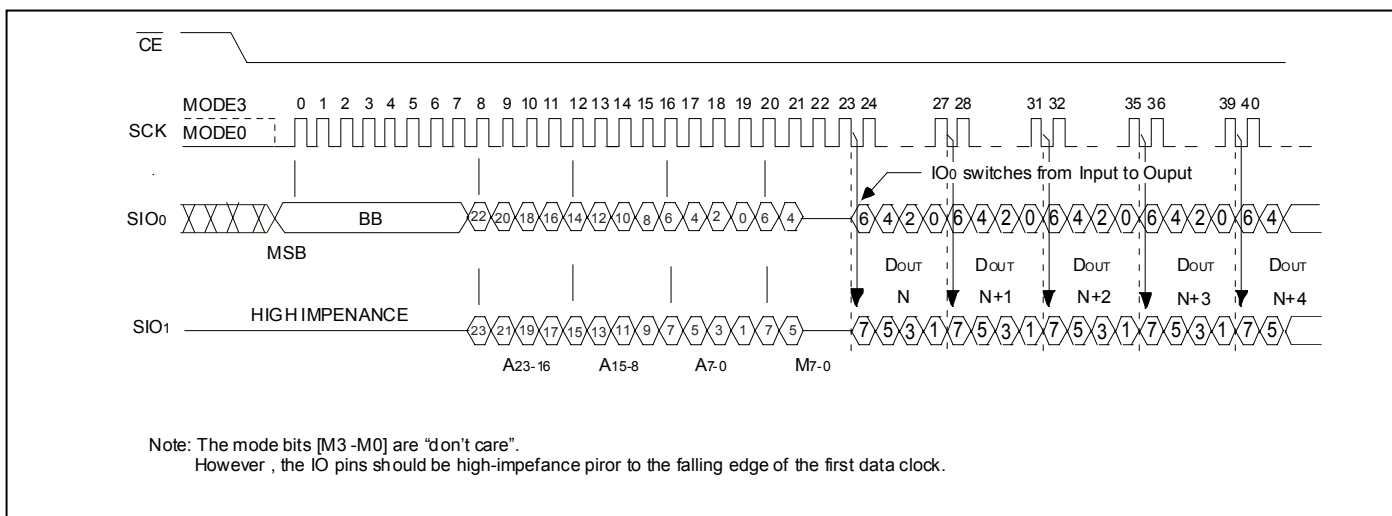

Figure 5: Fast Read Dual I/O Sequence ($[M_7-M_0] = 0xH$ or NOT AxH)

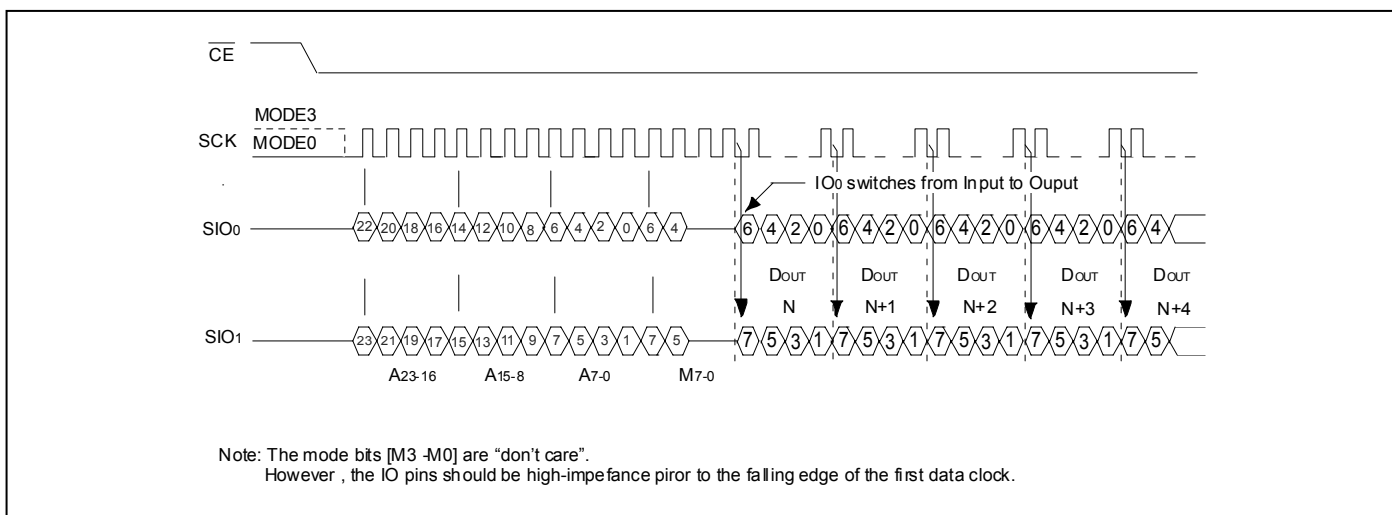

Figure 6: Fast Read Dual I/O Sequence ($[M_7-M_0] = \text{AxH}$)

Page Program (PP)

The Page Program instruction allows many bytes to be programmed in the memory. The bytes must be in the erased state (FFH) when initiating a Program operation. A Page Program instruction applied to a protected memory area will be ignored.

Prior to any Write operation, the Write Enable (WREN) instruction must be executed. \overline{CE} must remain active low for the duration of the Page Program instruction. The Page Program instruction is initiated by executing an 8-bit command, 02H, followed by address bits [A₂₃-A₀]. Following the address, at least one byte Data is input (the maximum of input data can be up to 256 bytes). If the 8 least significant address bits [A₇-A₀] are not all zero, all transmitted data that goes beyond the end of the current page are programmed from the start address of the same page (from the address whose 8 least significant bits [A₇-A₀] are all zero).

If more than 256 bytes Data are sent to the device, previously

latched data are discarded and the last 256 bytes Data are guaranteed to be programmed correctly within the same page. If less than 256 bytes Data are sent to device, they are correctly programmed at the requested addresses without having any effects on the other bytes of the same page.

\overline{CE} must be driven high before the instruction is executed. The user may poll the BUSY bit in the software status register or wait T_{PP} for the completion of the internal self-timed Page Program operation. While the Page Program cycle is in progress, the Read Status Register instruction may still be accessed for checking the status of the BUSY bit. It is recommended to wait for a duration of T_{BP} before reading the status register to check the BUSY bit. The BUSY bit is a 1 during the Page Program cycle and becomes a 0 when the cycle is finished and the device is ready to accept other instructions again. After the Page Program cycle has finished, the Write-Enable-Latch (WEL) bit in the Status Register is cleared to 0. See Figure 7 for the Page Program sequence.

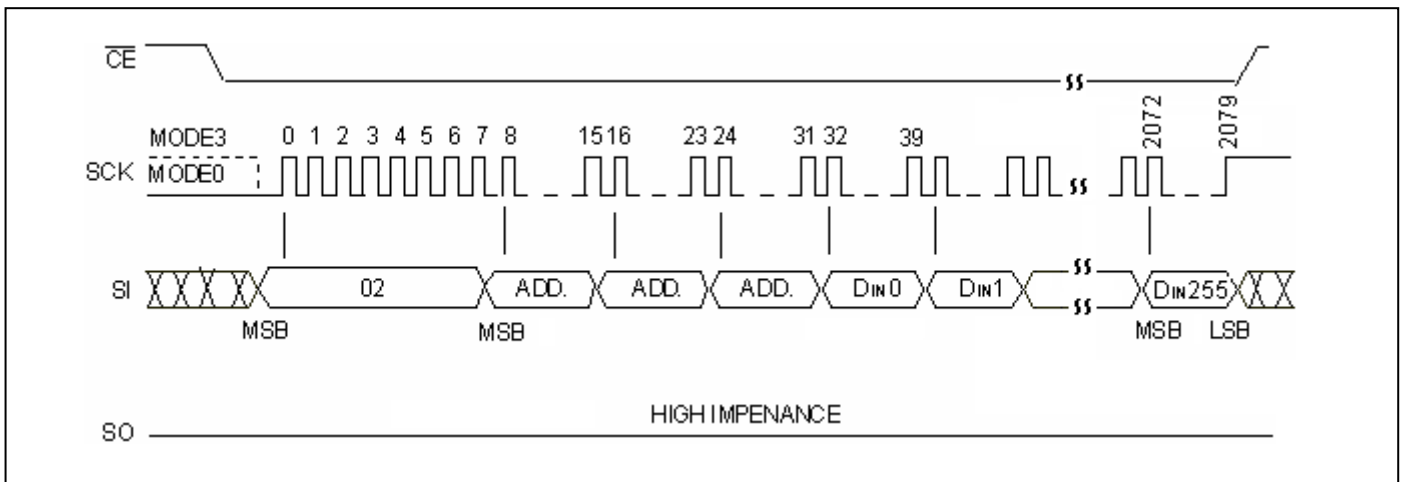

Figure 7: Page Program Sequence

Mode Bit Reset

Mode bits [M₇–M₀] are issued to further reduce instruction overhead for Fast Read Dual I/O operation. If [M₇–M₀] = “AxH”, the next Fast Read Dual I/O instruction doesn’t need the command code.

If the system controller is reset during operation, it will send a standard instruction (such as Read ID) to the Flash memory.

However, the device doesn’t have a hardware reset pin, so if [M₇–M₀] = “AxH”, the device will not recognize any standard SPI instruction. After a system reset, it is recommended to issue a Mode Bit Reset instruction first to release the status of [M₇–M₀] = “AxH” and allow the device to recognize standard SPI instruction. See Figure 8 for the Mode Bit Reset instruction.

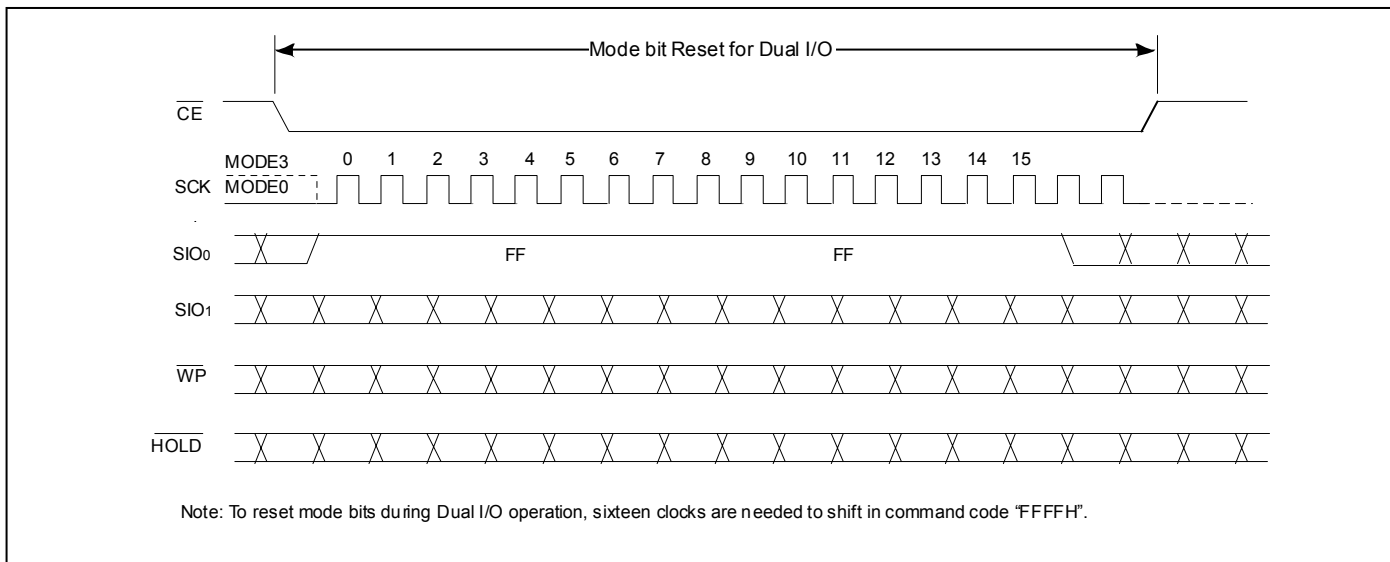

Figure 8: Mode Bit Reset Instruction

64K Byte Block Erase

The 64K-byte Block Erase instruction clears all bits in the selected block to FFH. A Block Erase instruction applied to a protected memory area will be ignored. Prior to any Write operation, the Write Enable (WREN) instruction must be executed. \overline{CE} must remain active low for the duration of the any command sequence. The Block Erase instruction is initiated by executing an 8-bit command, D8H, followed by address bits [A₂₃

-A₀]. Address bits [A_{MS}-A₁₆] (A_{MS} = Most Significant address) are used to determine the block address (BA_x), remaining address bits can be V_{IL} or V_{IH}. \overline{CE} must be driven high before the instruction is executed. The user may poll the BUSY bit in the Software Status Register or wait T_{BE} for the completion of the internal self-timed Block Erase cycle. See Figure 9 for 64K Byte Block Erase sequence.

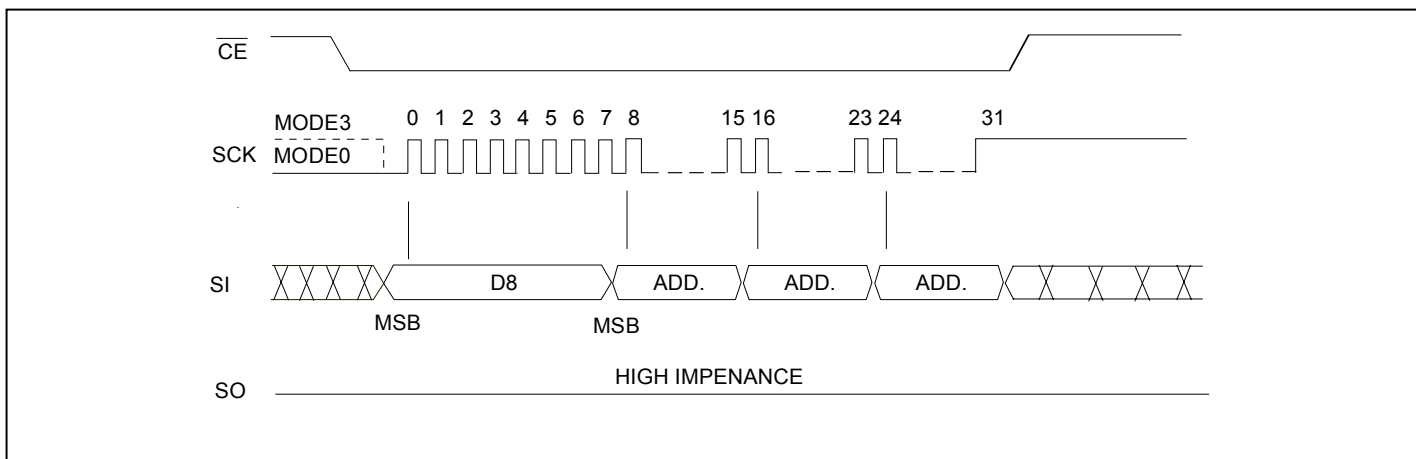

Figure 9: 64K-byte Block Erase Sequence

32K Byte Block Erase

The 32K-byte Block Erase instruction clears all bits in the selected block to FFH. A Block Erase instruction applied to a protected memory area will be ignored. Prior to any Write operation, the Write Enable (WREN) instruction must be executed. \overline{CE} must remain active low for the duration of the any command sequence. The Block Erase instruction is initiated by executing an 8-bit command, 52H, followed by address bits [A₂₃

-A₀]. Address bits [A_{MS}-A₁₅] (A_{MS} = Most Significant address) are used to determine the block address (BA_x), remaining address bits can be V_{IL} or V_{IH}. \overline{CE} must be driven high before the instruction is executed. The user may poll the BUSY bit in the Software Status Register or wait T_{BE} for the completion of the internal self-timed Block Erase cycle. See Figure 10 for 32K Byte Block Erase sequence.

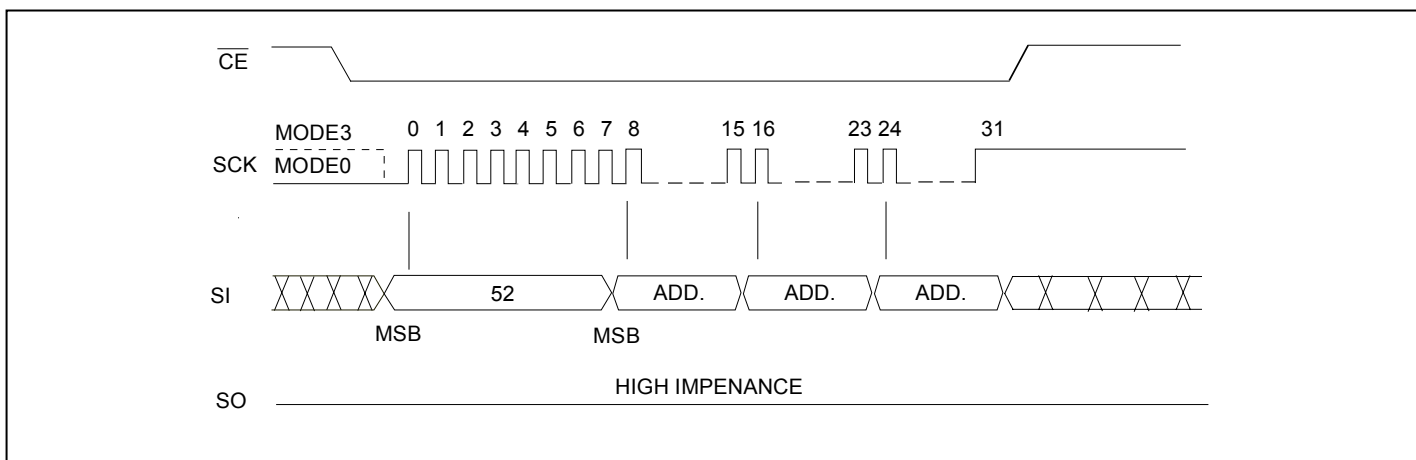

Figure 10: 32K-byte Block Erase Sequence

4K Byte Sector Erase

The Sector Erase instruction clears all bits in the selected sector to FFH. A Sector Erase instruction applied to a protected memory area will be ignored. Prior to any Write operation, the Write Enable (WREN) instruction must be executed. \overline{CE} must remain active low for the duration of the any command sequence. The Sector Erase instruction is initiated by executing an 8-bit command, 20H, followed by address bits [A₂₃-A₀]. Address bits

[A_{MS}-A₁₂] (A_{MS} = Most Significant address) are used to determine the sector address (SA_x), remaining address bits can be V_{IL} or V_{IH}. \overline{CE} must be driven high before the instruction is executed. The user may poll the BUSY bit in the Software Status Register or wait T_{SE} for the completion of the internal self-timed Sector Erase cycle. See Figure 11 for the Sector Erase sequence.

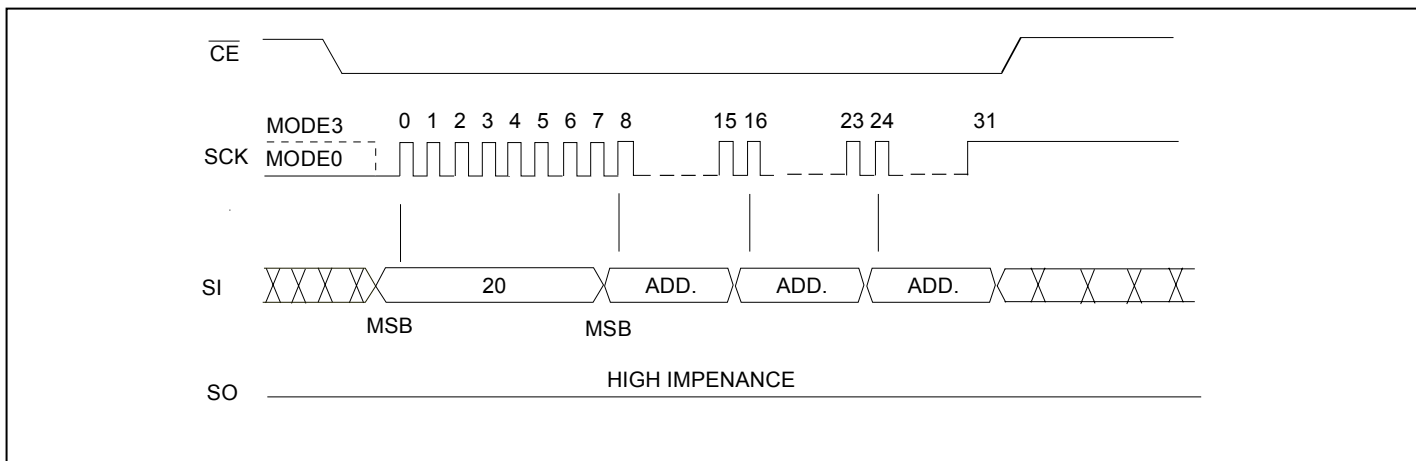

Figure 11: 4K-byte Sector Erase Sequence

Chip Erase

The Chip Erase instruction clears all bits in the device to FFH. A Chip Erase instruction will be ignored if any of the memory area is protected. Prior to any Write operation, the Write Enable (WREN) instruction must be executed. \overline{CE} must remain active low for the duration of the Chip Erase instruction sequence. The Chip

Erase instruction is initiated by executing an 8-bit command, 60H or C7H. \overline{CE} must be driven high before the instruction is executed. The user may poll the BUSY bit in the Software Status Register or wait T_{CE} for the completion of the internal self-timed Chip Erase cycle. See Figure 12 for the Chip Erase sequence.

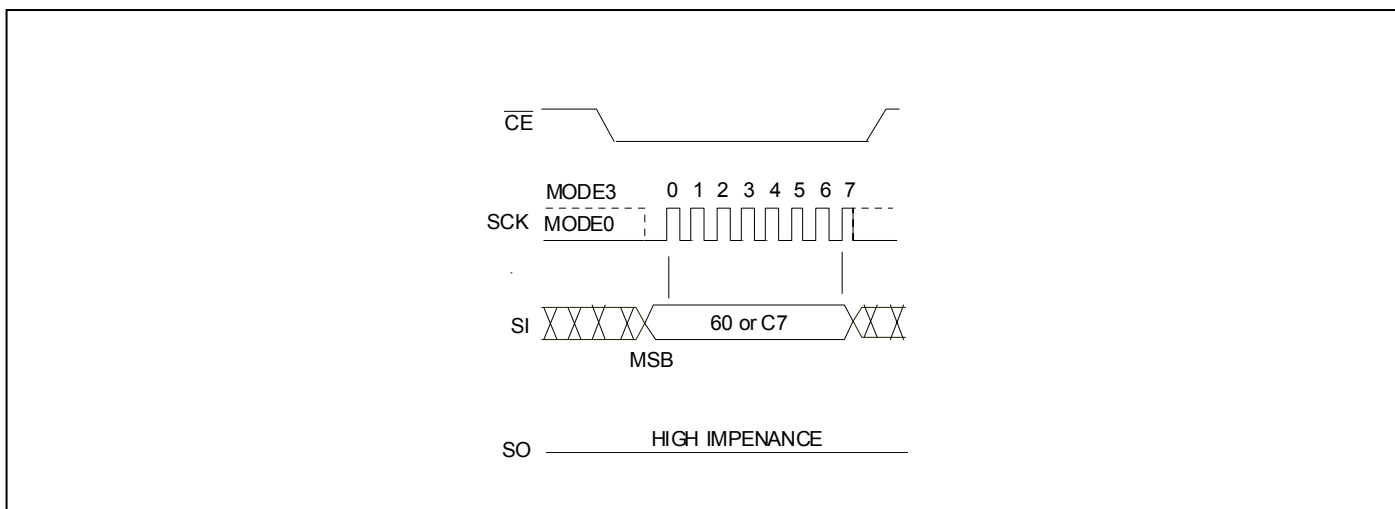

Figure 12: Chip Erase Sequence

Erase Suspend

The Erase Suspend instruction allows the system to interrupt a Sector or Block Erase operation and then read from any other sector or block. The Write Status Register instruction and Sector / Block Erase instructions are not allowed during suspend. Erase Suspend is valid only during the Sector or Block Erase operation. If written during the Chip Erase or Program operation, the Erase

Suspend instruction is ignored. A maximum of T_{SUS} is required to suspend the erase operation. The BUSY bit in the Software Status Register will clear to "0" after Erase Suspend. A power-off during the suspend period will reset the device and release the suspend status.

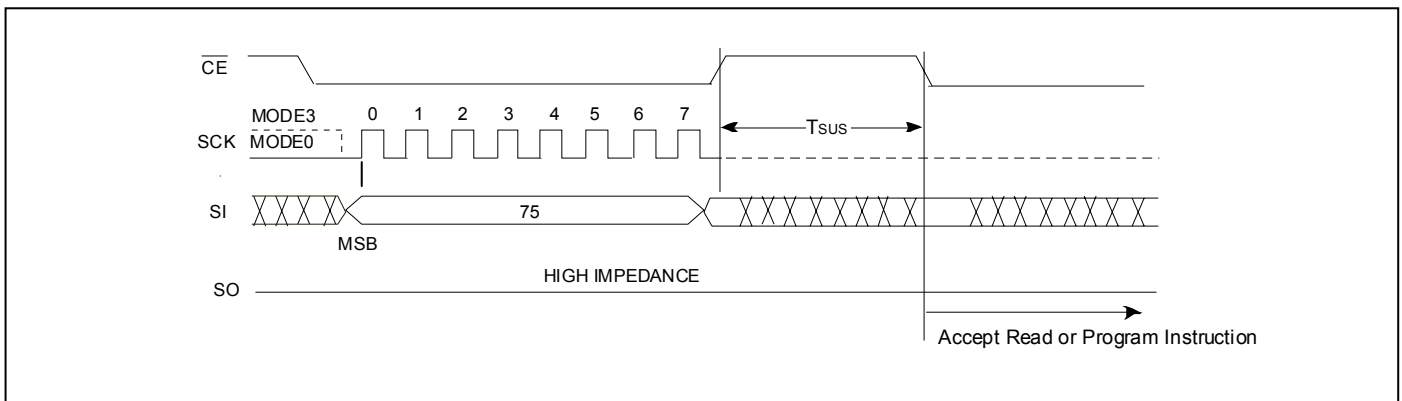

Figure 13: Erase Suspend Instruction

Erase Resume

The Erase Resume instruction must be written to resume the Sector or Block Erase operation after Erase Suspend. After issued the BUSY bit in the Software Status Register will be set to

"1" and the sector or block will complete the erase operation. Erase Resume instruction will be ignored unless an Erase Suspend operation is active.

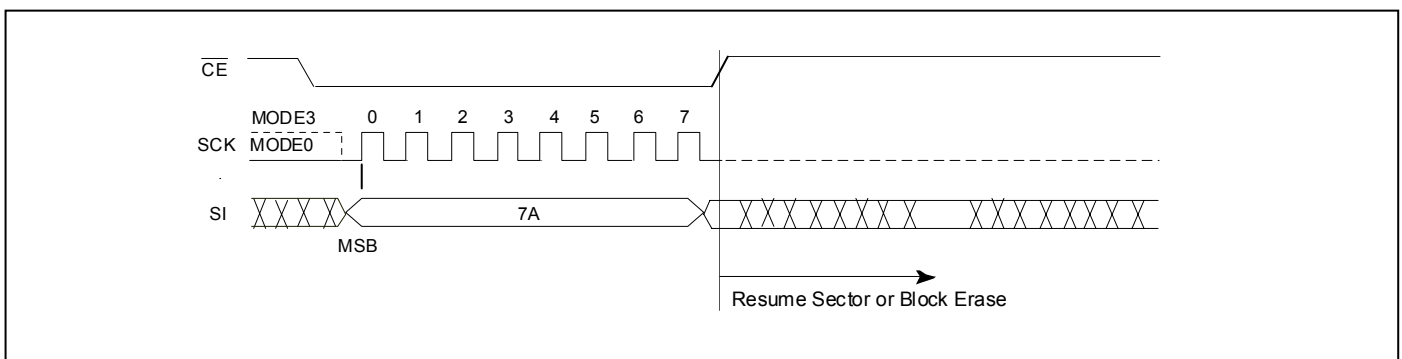

Figure 14: Erase Resume Instruction

Write Enable (WREN)

The Write Enable (WREN) instruction sets the Write-Enable-Latch bit in the Software Status Register to 1 allowing Write operations to occur. The WREN instruction must be executed prior to any Write

(Program/Erase) operation. \overline{CE} must be driven high before the WREN instruction is executed.

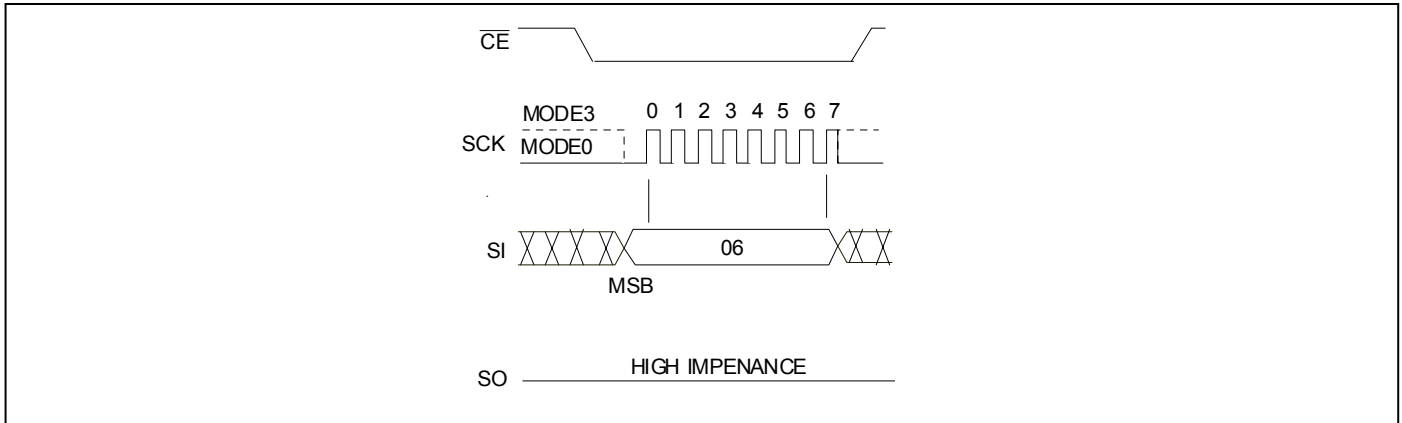

Figure 15: Write Enable (WREN) Sequence

Write Disable (WRDI)

The Write Disable (WRDI) instruction resets the Write-Enable-Latch bit to 0 disabling any new Write operations from occurring or exits from OTP mode to normal mode.

\overline{CE} must be driven high before the WRDI instruction is executed.

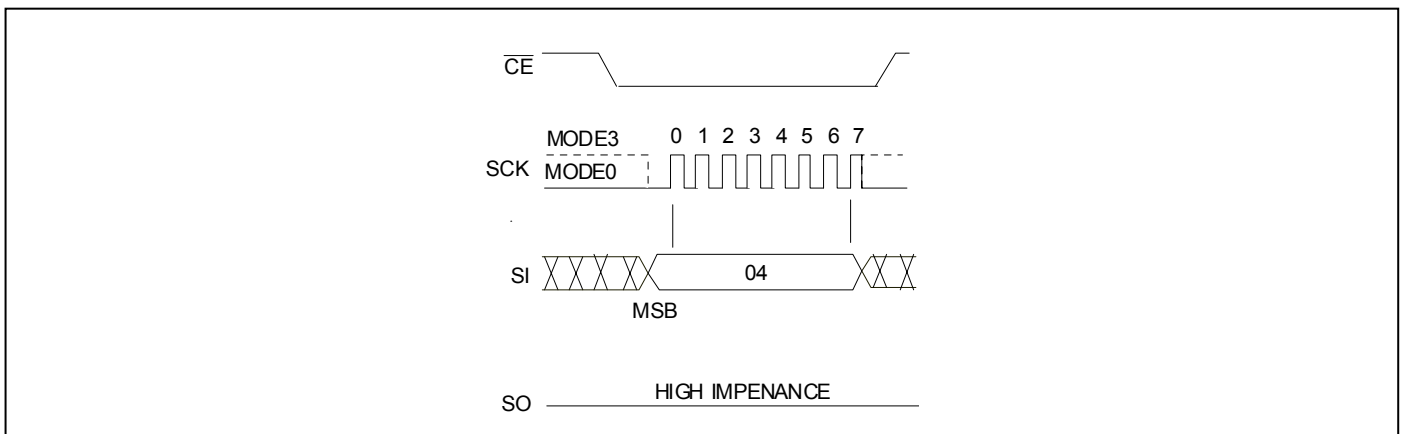

Figure 16: Write Disable (WRDI) Sequence

Write Status Register (WRSR)

The Write Status Register instruction writes new values to the BP3, BP2, BP1, BP0 and BPL (Status Register) bits of the status register. \overline{CE} must be driven low before the command sequence of the WRSR instruction is entered and driven high before the WRSR instruction is executed. \overline{CE} must be driven high after the eighth or sixteenth bit of data that is clocked in. If it is not done, the WRSR instruction will not be issued. See Figure 17 for WREN and WRSR instruction sequences.

Executing the Write Status Register instruction will be ignored when \overline{WP} is low and BPL bit is set to "1". When the \overline{WP} is low, the BPL bit can only be set from "0" to "1" to lock down the status register, but cannot be reset from "1" to "0".

When \overline{WP} is high, the lock-down function of the BPL bit is disabled and the BPL, BP0, BP1, BP2 and BP3 bits in the status register can all be changed. As long as BPL bit is set to 0 or \overline{WP} pin is driven high (V_{IH}) prior to the low-to-high transition of the \overline{CE} pin at the end of the WRSR instruction, the bits in the status register can all be altered by the WRSR instruction. In this case, a single WRSR instruction can set the BPL bit to "1" to lock down the status register as well as altering the BP0; BP1, BP2 and BP3 bits at the same time. See Table 4 for a summary description of \overline{WP} and BPL functions.

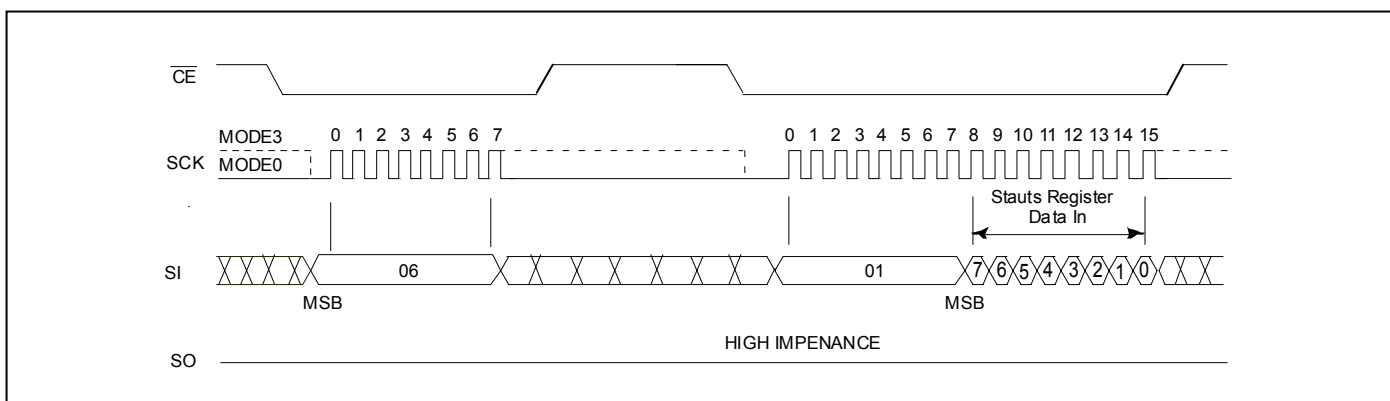

Figure 17: Write Enable (WREN) and Write Status Register (WRSR)

Read Status Register (RDSR)

The Read Status Register (RDSR) instruction allows reading of the status register. The status register may be read at any time even during a Write (Program/Erase) operation. When a Write operation is in progress, the BUSY bit may be checked before sending any new commands to assure that the new commands are properly received by the device.

\overline{CE} must be driven low before the RDSR instruction is entered and remain low until the status data is read. The RDSR instruction code is "05H" for Status Register. Read Status Register is continuous with ongoing clock cycles until it is terminated by a low to high transition of the \overline{CE} . See Figure 18 for the RDSR instruction sequence.

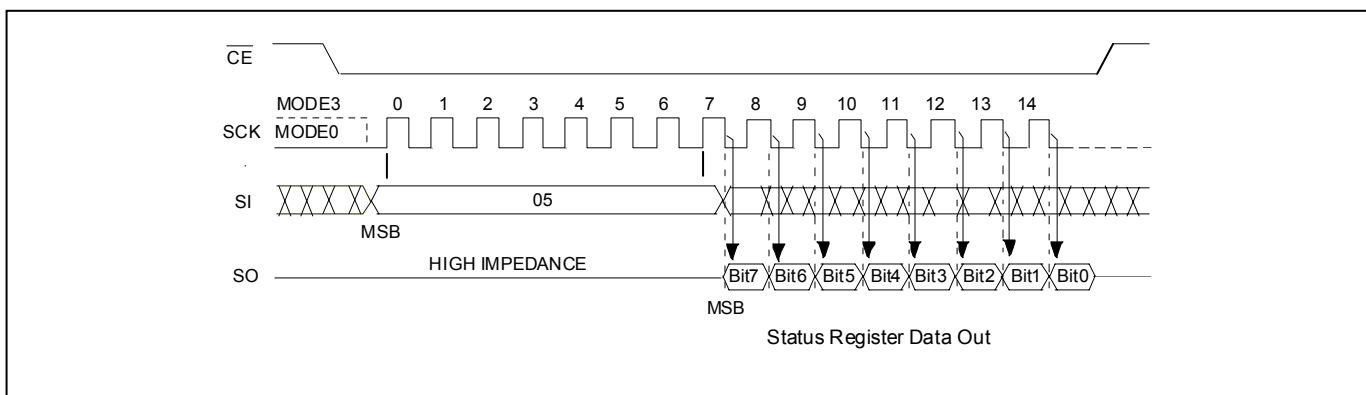

Figure 18: Read Status Register (RDSR) Sequence

Enter OTP Mode (ENSO)

The ENSO (B1H) instruction is for entering the additional 512 bytes secured OTP mode. The additional 512 bytes secured OTP sector is independent from main array, which may use to store unique serial number for system identifier. User must unprotect whole array (BP0=BP1=BP2=BP3=0), prior to any Program operation in OTP sector. After entering the secured OTP mode, only the secured OTP sector can be accessed and user can only follow the Read or Program procedure with OTP address range

(address bits [A₂₃ –A₉] must be “0”). The secured OTP data cannot be updated again once it is lock down or has been programmed. In secured OTP mode, WRSR command will ignore the input data and lock down the secured OTP sector (OTP_lock bit =1). To exit secured OTP mode, user must execute WRDI command. RES can be used to verify the secured OTP status as shown in Table 6.

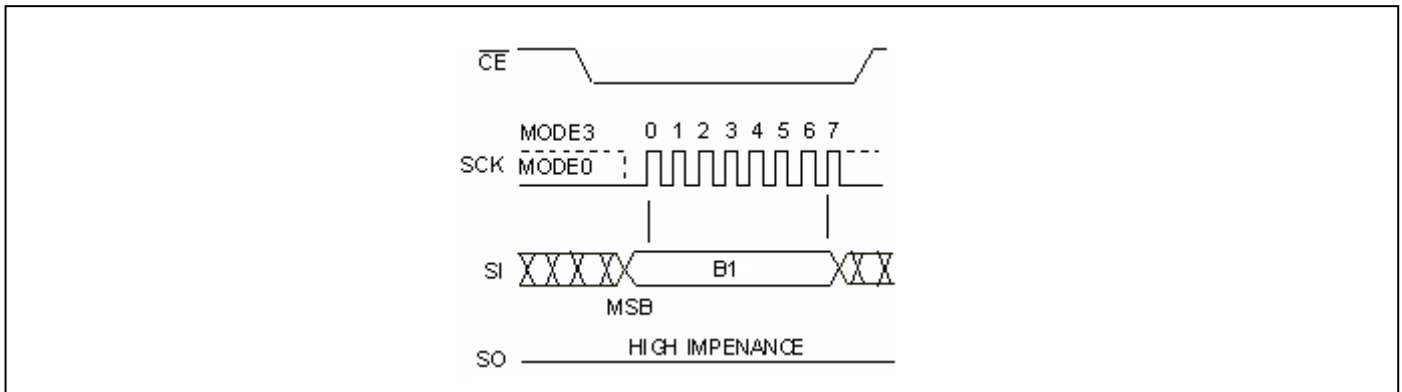

Figure 19: Enter OTP Mode (ENSO) Sequence

OTP Sector Address

Size	Address Range
512 bytes	000000H ~ 0001FFH

Note: The OTP sector is an independent Sector.

Deep Power Down (DP)

The Deep Power Down instruction is for minimizing power consumption (the standby current is reduced from I_{SB1} to I_{SB2}).

This instruction is initiated by executing an 8-bit command, B9H, and then \overline{CE} must be driven high. After \overline{CE} is driven high, the device will enter to deep power down within the duration of T_{DP} .

Once the device is in deep power down status, all instructions will be ignored except the Release from Deep Power Down instruction (RDP) and Read Electronic Signature instruction (RES). The device always power-up in the normal operation with the standby current (I_{SB1}). See Figure 20 for the Deep Power Down instruction.

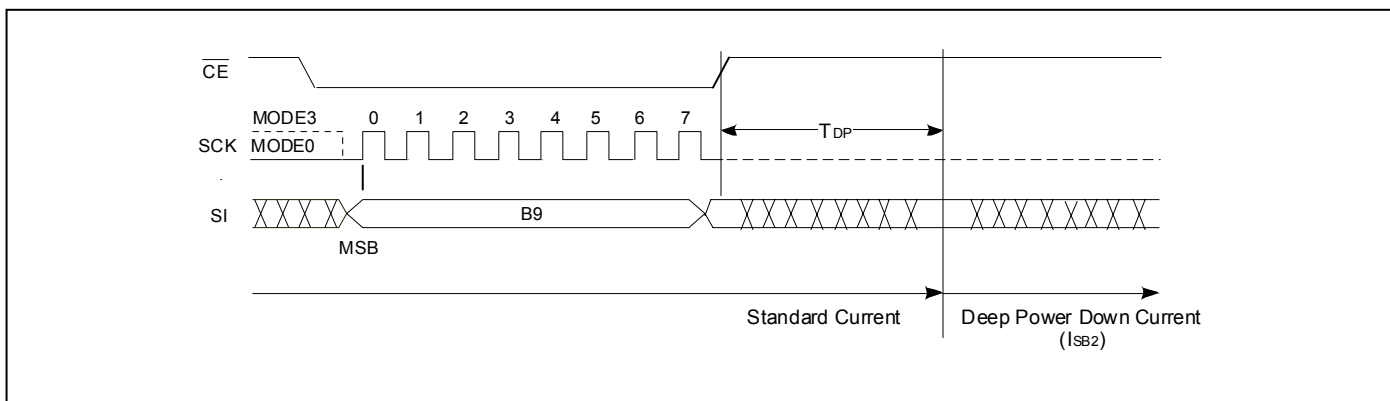

Figure 20: Deep Power Down Instruction

Release from Deep Power Down (RDP) and Read Electronic-Signature (RES)

The Release from Deep Power Down and Read Electronic-Signature instruction is a multi-purpose instruction.

The instruction can be used to release the device from the deep power down status. This instruction is initiated by driving \overline{CE} low and executing an 8-bit command, ABH, and then drive \overline{CE} high. See Figure 21 for RDP instruction. Release from the deep power down will take the duration of T_{RES1} before the device will resume normal operation and other instructions are accepted. \overline{CE} must remain high during T_{RES1} .

The instruction also can be used to read the 8-bit Electronic-Signature of the device on the SO pin. It is initiated by driving

\overline{CE} low and executing an 8-bit command, ABH, followed by 3 dummy bytes. The Electronic-Signature byte is then output from the device. The Electronic-Signature can be read continuously until \overline{CE} go high. See Figure 22 for RES sequence. After driving \overline{CE} high, it must remain high during for the duration of T_{RES2} , and then the device will resume normal operation and other instructions are accepted.

The instruction is executed while an Erase, Program or WRSR cycle is in progress is ignored and has no effect on the cycle in progress. In OTP mode, user also can execute RES to confirm the status of OTP.

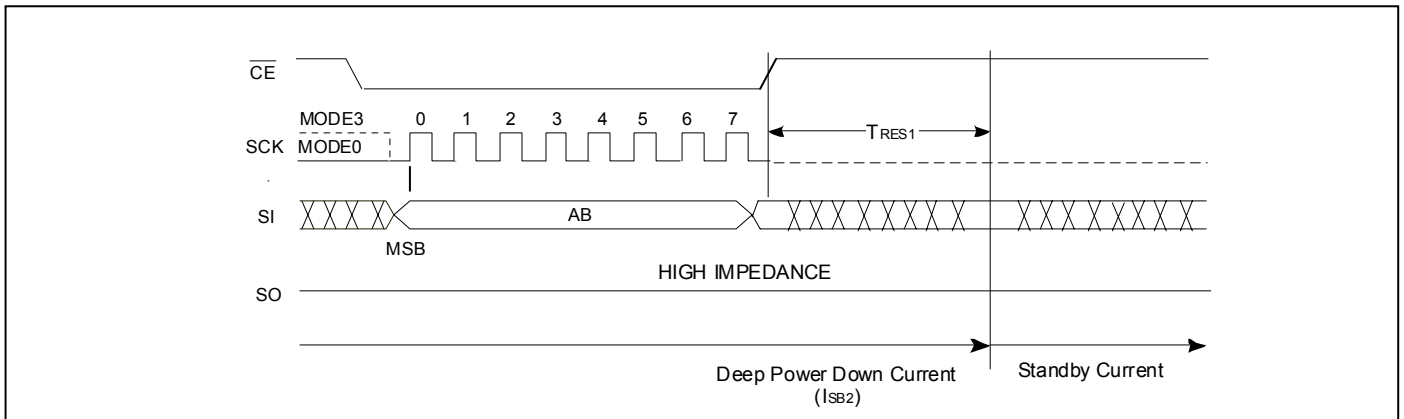

Figure 21: Release from Deep Power Down (RDP) Instruction

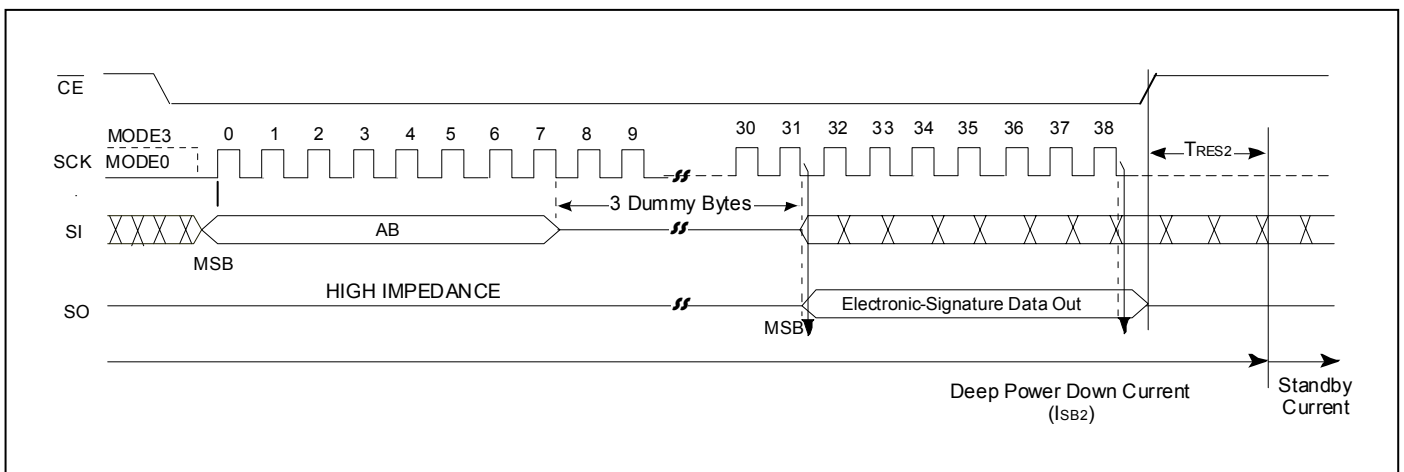

Figure 22: Read Electronic -Signature (RES) Sequence

Table 6: Electronic Signature Data

Command	Mode	Electronic Signature Data
RES	Normal	14H
	In secured OTP mode & non lock down (OTP_lock =0)	34H
	In secured OTP mode & lock down (OTP_lock =1)	74H

JEDEC Read-ID

The JEDEC Read-ID instruction identifies the device as F25L16PA and the manufacturer as ESMT. The device information can be read from executing the 8-bit command, 9FH. Following the JEDEC Read-ID instruction, the 8-bit manufacturer's ID, 8CH, is output from the device. After that, a 16-bit device ID is shifted out on the SO pin. Byte1, 8CH, identifies the manufacturer as ESMT. Byte2, 21H, identifies the memory type as SPI Flash. Byte3, 15H, identifies the device as

F25L16PA. The instruction sequence is shown in Figure 23. The JEDEC Read ID instruction is terminated by a low to high transition on \overline{CE} at any time during data output. If no other command is issued after executing the JEDEC Read-ID instruction, issue a 00H (NOP) command before going into Standby Mode ($\overline{CE} = V_{IH}$).

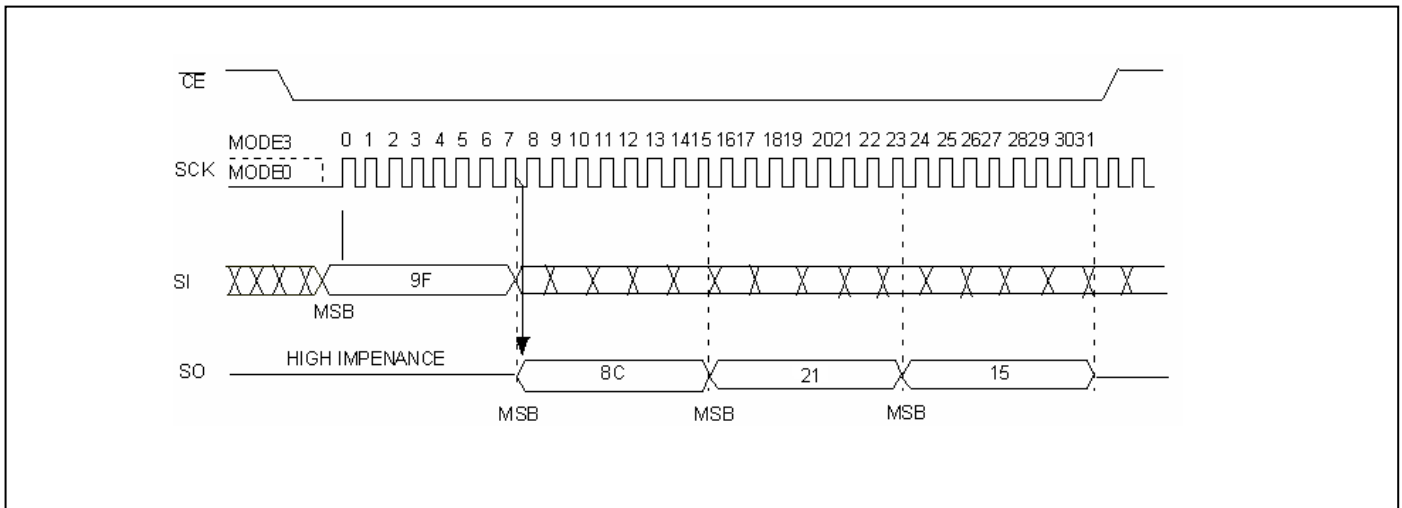

Figure 23: JEDEC Read-ID Sequence

Table 7: JEDEC Read-ID Data

Manufacturer's ID (Byte 1)	Device ID	
	Memory Type (Byte 2)	Memory Capacity (Byte 3)
8CH	21H	15H

Read-ID (RDID)

The Read-ID instruction (RDID) identifies the devices as F25L16PA and manufacturer as ESMT. This command is backward compatible to all ESMT SPI devices and should be used as default device identification when multiple versions of ESMT SPI devices are used in one design. The device information can be read from executing an 8-bit command, 90H, followed by address bits [A₂₃ -A₀]. Following the Read-ID

instruction, the manufacturer's ID is located in address 000000H and the device ID is located in address 000001H. Once the device is in Read-ID mode, the manufacturer's and device ID output data toggles between address 000000H and 000001H until terminated by a low to high transition on \overline{CE} .

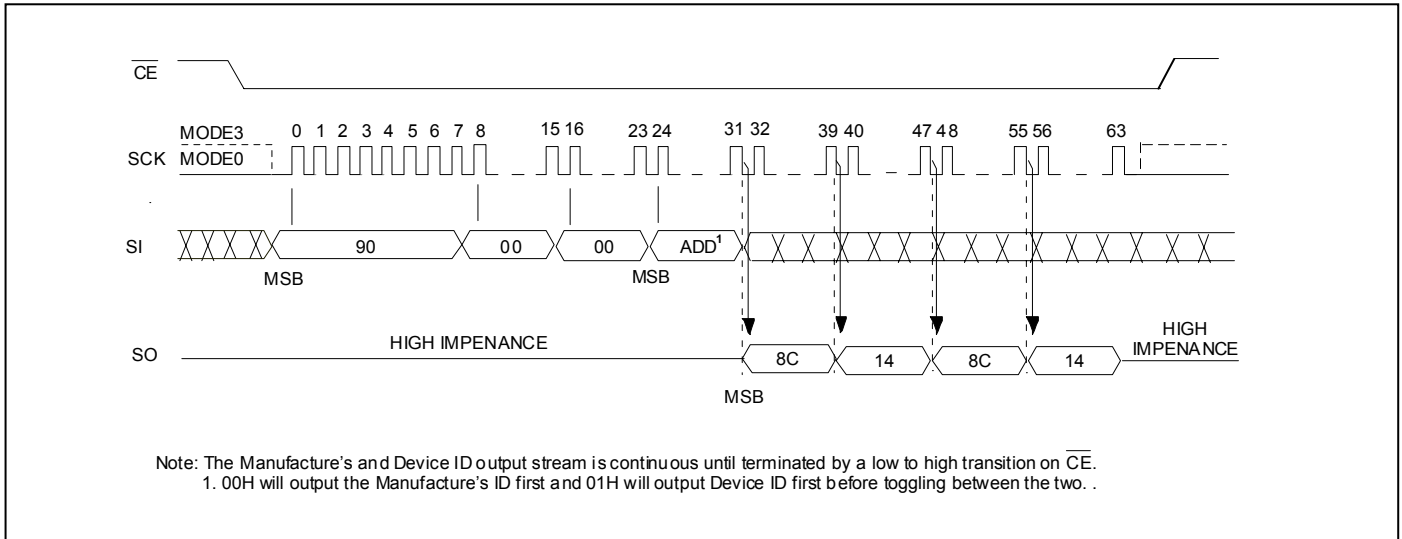

Figure 24: Read ID Sequence

Table 8: Product ID Data

Address	Byte1	Byte2
000000H	8CH	14H
	Manufacturer's ID	Device ID ESMT F25L16PA
000001H	14H	8CH
	Device ID ESMT F25L16PA	Manufacturer's ID

■ ELECTRICAL SPECIFICATIONS

Absolute Maximum Stress Ratings

(Applied conditions are greater than those listed under “Absolute Maximum Stress Ratings” may cause permanent damage to the device. This is a stress rating only and functional operation of the device at these conditions or conditions greater than those defined in the operational sections of this datasheet is not implied. Exposure to absolute maximum stress rating conditions may affect device reliability.)

Storage Temperature	-65°C to +150°C
D. C. Voltage on Any Pin to Ground Potential	-0.5V to VDD+0.5V
Transient Voltage (<20 ns) on Any Pin to Ground Potential	-2.0V to VDD+2.0V
Package Power Dissipation Capability (T _A = 25°C)	1.0W
Surface Mount Lead Soldering Temperature (3 Seconds)	260°C
Output Short Circuit Current (Note 1).	50 mA

(Note 1: Output shorted for no more than one second. No more than one output shorted at a time.)

TABLE 9: AC CONDITIONS OF TEST

Input Rise/Fall Time	5 ns
Output Load	C _L = 15 pF for ≥ 75MHz
.	C _L = 30 pF for ≤ 50MHz
See Figures 30 and 31	

TABLE 10: OPERATING RANGE

Parameter	Symbol	Value	Unit
Operating Supply Voltage	V _{DD}	2.7 ~ 3.6	V
Ambient Operating Temperature	T _A	-40 ~ +85	°C

TABLE 11: DC OPERATING CHARACTERISTICS

Symbol	Parameter	Limits			Test Condition
		Min	Max	Unit	
I _{DDR1}	Read Current @ 50MHz	Standard	10	mA	$\overline{CE} = 0.1 V_{DD}/0.9 V_{DD}$, SO=open
		Dual	12		
I _{DDR2}	Read Current @ 86MHz	Standard	15	mA	$\overline{CE} = 0.1 V_{DD}/0.9 V_{DD}$, SO=open
		Dual	16.5		
I _{DDR3}	Read Current @ 100MHz	Standard	22	mA	$\overline{CE} = 0.1 V_{DD}/0.9 V_{DD}$, SO=open
		Dual	23.5		
I _{DDW}	Program and Write Status Register Current		15	mA	$\overline{CE} = V_{DD}$
I _{DDE}	Sector and Block Erase Current		15	mA	$\overline{CE} = V_{DD}$
	Chip Erase Current		20	mA	$\overline{CE} = V_{DD}$
I _{SB1}	Standby Current		25	µA	$\overline{CE} = V_{DD}$, V _{IN} = V _{DD} or V _{SS}
I _{SB2}	Deep Power Down Current		10	µA	$\overline{CE} = V_{DD}$, V _{IN} = V _{DD} or V _{SS}
I _{LI}	Input Leakage Current		1	µA	V _{IN} =GND to V _{DD} , V _{DD} =V _{DD} Max
I _{LO}	Output Leakage Current		1	µA	V _{OUT} =GND to V _{DD} , V _{DD} =V _{DD} Max
V _{IL}	Input Low Voltage	-0.5	0.3 x V _{DD}	V	
V _{IH}	Input High Voltage	0.7 x V _{DD}	V _{DD} +0.4	V	
V _{OL}	Output Low Voltage		0.4	V	I _{OL} =1.6 mA
V _{OH}	Output High Voltage	V _{DD} -0.2		V	I _{OH} =-100 µA

TABLE 12: LATCH UP CHARACTERISTIC

Symbol	Parameter	Minimum	Unit	Test Method
I_{LTH}^1	Latch Up	$100 + I_{DD}$	mA	JEDEC Standard 78

Note 1: This parameter is measured only for initial qualification and after a design or process change that could affect this parameter.

TABLE 13: CAPACITANCE (TA = 25°C, f=1 MHz, other pins open)

Parameter	Description	Test Condition	Maximum
C_{OUT}^1	Output Pin Capacitance	$V_{OUT} = 0V$	8 pF
C_{IN}^1	Input Capacitance	$V_{IN} = 0V$	6 pF

Note 1: This parameter is measured only for initial qualification and after a design or process change that could affect this parameter.

TABLE 14: AC OPERATING CHARACTERISTICS

Symbol	Parameter	50 MHz		86 MHz		100 MHz		Unit
		Min	Max	Min	Max	Min	Max	
F_{CLK}	Serial Clock Frequency		50		86		100	MHz
T_{SCKH}	Serial Clock High Time	9		6		4		ns
T_{SCKL}	Serial Clock Low Time	9		6		4		ns
T_{CLCH}^2	Clock Rise Time (Slew Rate)	0.1		0.1		0.1		V/ns
T_{CHCL}^2	Clock Fall Time (Slew Rate)	0.1		0.1		0.1		V/ns
T_{CES}^1	\overline{CE} Active Setup Time	5		5		5		ns
T_{CEH}^1	\overline{CE} Active Hold Time	5		5		5		ns
T_{CHS}^1	\overline{CE} Not Active Setup Time	5		5		5		ns
T_{CHH}^1	\overline{CE} Not Active Hold Time	5		5		5		ns
T_{CPH}	\overline{CE} Deselect Time	Read	15		15		15	ns
		Write/Erase/Program	50		50		50	ns
T_{CHZ}	\overline{CE} High to High-Z Output		7		7		7	ns
T_{CLZ}	SCK Low to Low-Z Output	0		0		0		ns
T_{DS}	Data In Setup Time	2		2		2		ns
T_{DH}	Data In Hold Time	1		1		1		ns
T_{HLS}	\overline{HOLD} Low Setup Time	5		5		5		ns
T_{HHS}	\overline{HOLD} High Setup Time	5		5		5		ns
T_{HLH}	\overline{HOLD} Low Hold Time	5		5		5		ns
T_{HHH}	\overline{HOLD} High Hold Time	5		5		5		ns
T_{HZ}^3	\overline{HOLD} Low to High-Z Output		8		8		8	ns
T_{LZ}^3	\overline{HOLD} High to Low-Z Output		8		8		8	ns

TABLE 14: AC OPERATING CHARACTERISTICS - Continued

Symbol	Parameter	50 MHz		86 MHz		100 MHz		Unit
		Min	Max	Min	Max	Min	Max	
T _{OH}	Output Hold from SCK Change	0		0		0		ns
T _V	Output Valid from SCK		8		8		8	ns
T _{WHSL} ⁴	Write Protect Setup Time before \overline{CE} Low		20		20		20	ns
T _{SHWL} ⁴	Write Protect Hold Time after \overline{CE} High		100		100		100	ns
T _{DP} ³	\overline{CE} High to Deep Power Down Mode		3		3		3	us
T _{RES1} ³	\overline{CE} High to Standby Mode (for DP)		3		3		3	us
T _{RES2} ³	\overline{CE} High to Standby Mode (for RES)		1.8		1.8		1.8	us
T _{SUS} ³	\overline{CE} High to next Instruction after Suspend		20		20		20	us

Note:

1. Relative to SCK.
2. T_{SCKH} + T_{SCKL} must be less than or equal to 1/ F_{CLK}.
3. Value guaranteed by characterization, not 100% tested in production.
4. Only applicable as a constraint for a Write status Register instruction when Block- Protection-Look (BPL) bit is set at 1.

TABLE 15: ERASE AND PROGRAMMING PERFORMANCE

Parameter	Symbol	Limit		Unit
		Typ ²	Max ³	
Sector Erase Time (4KB)	T _{SE}	120	250	ms
Block Erase Time (32KB)	T _{BE1}	500	1000	ms
Block Erase Time (64KB)	T _{BE2}	1	2	s
Chip Erase Time	T _{CE}	10	30	s
Write Status Register Time	T _W	10	15	ms
Page Programming Time	T _{PP}	1.5	5	ms
Erase/Program Cycles ¹		100,000	-	Cycles
Data Retention		20	-	Years

Notes:

1. Not 100% Tested, Excludes external system level over head.
2. Typical values measured at 25°C, 3V.
3. Maximum values measured at 85°C, 2.7V.

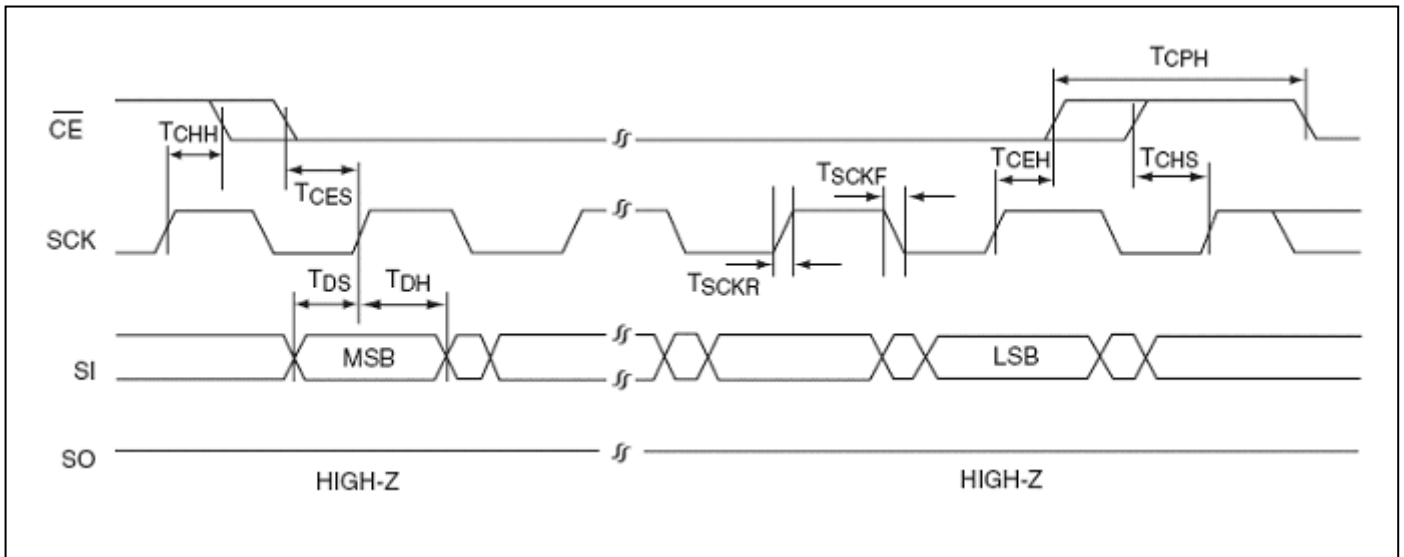

Figure 25: Serial Input Timing Diagram

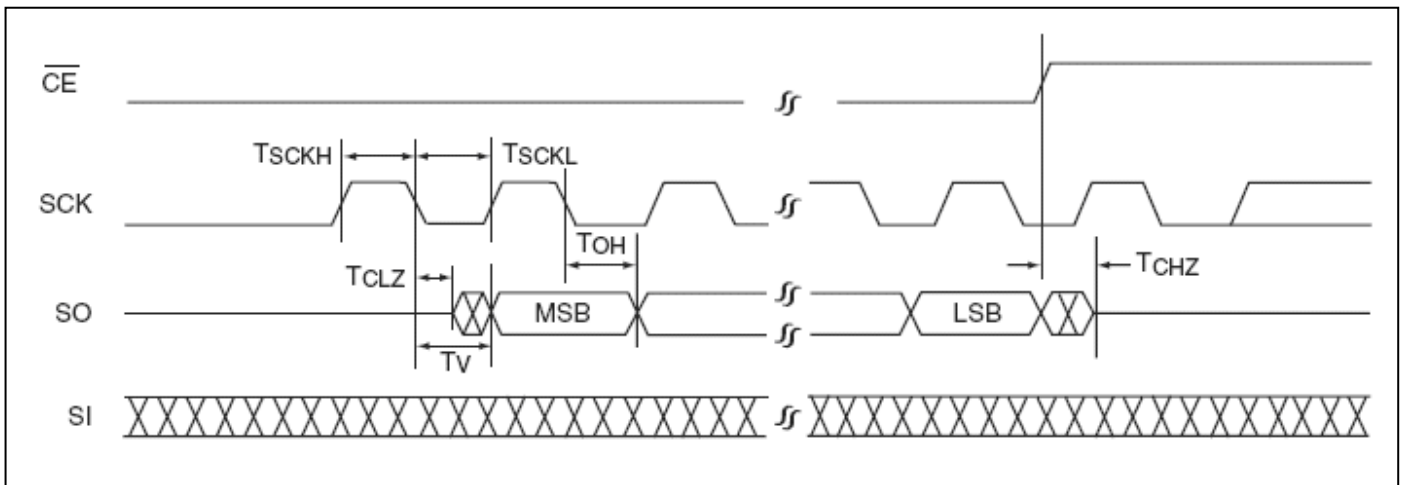

Figure 26: Serial Output Timing Diagram

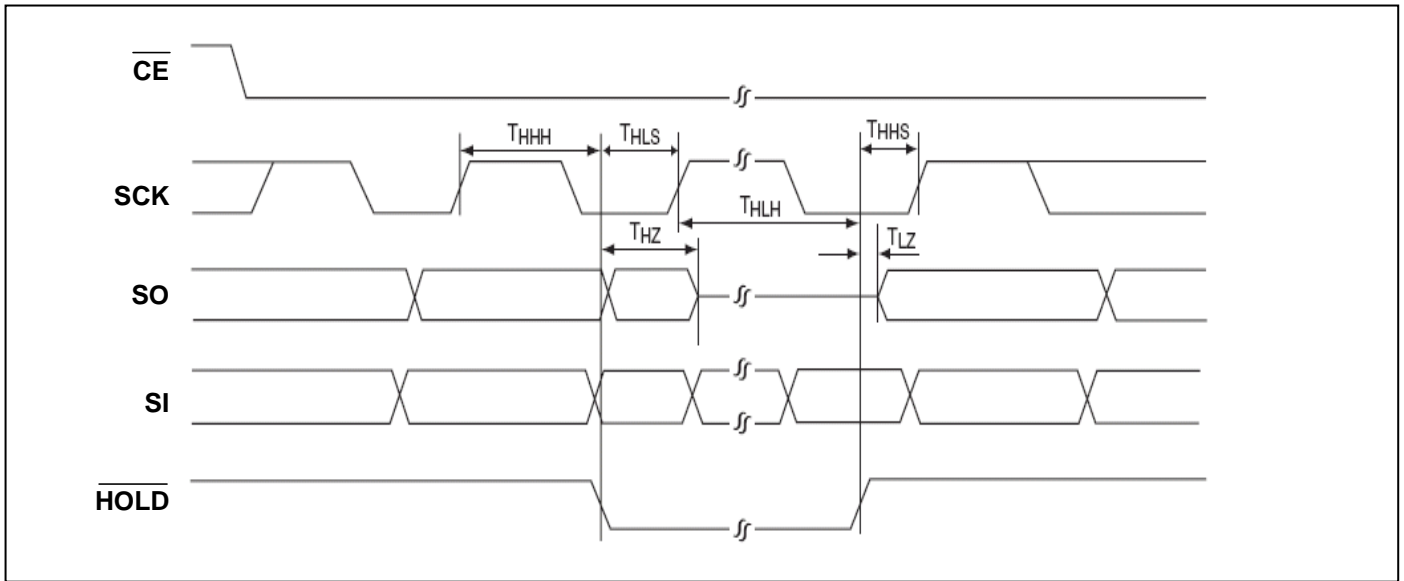

Figure 27: HOLD Timing Diagram

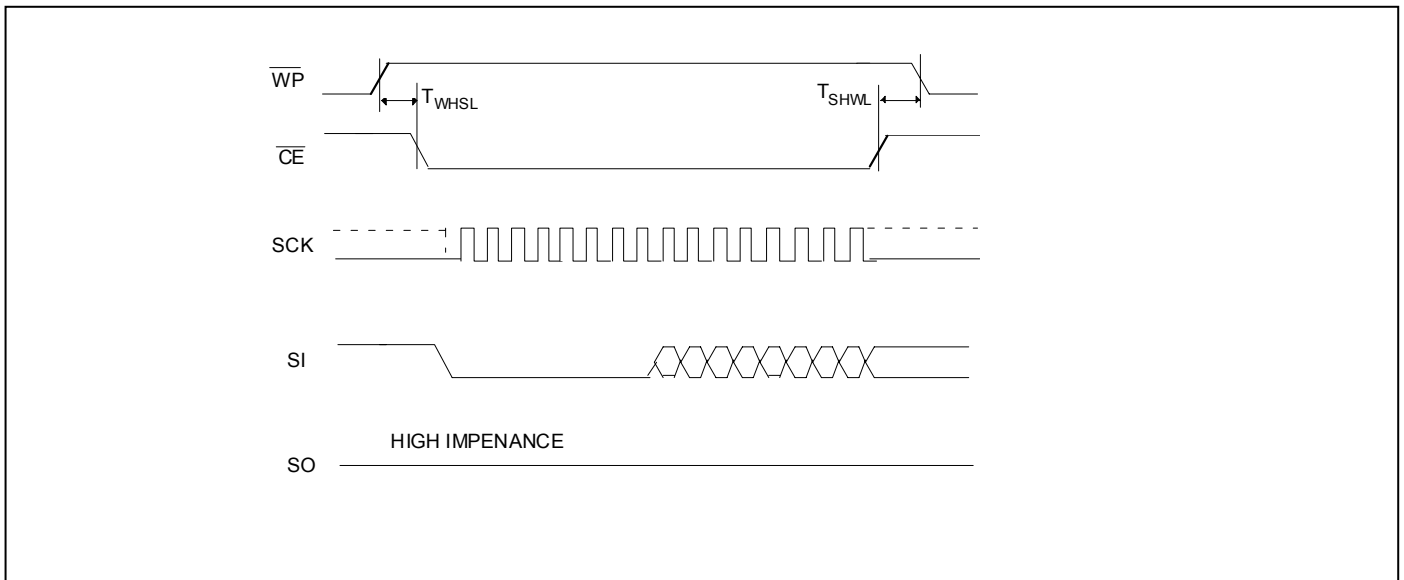

Figure 28: Write Protect setup and hold timing during WRSR when $BPL = 1$

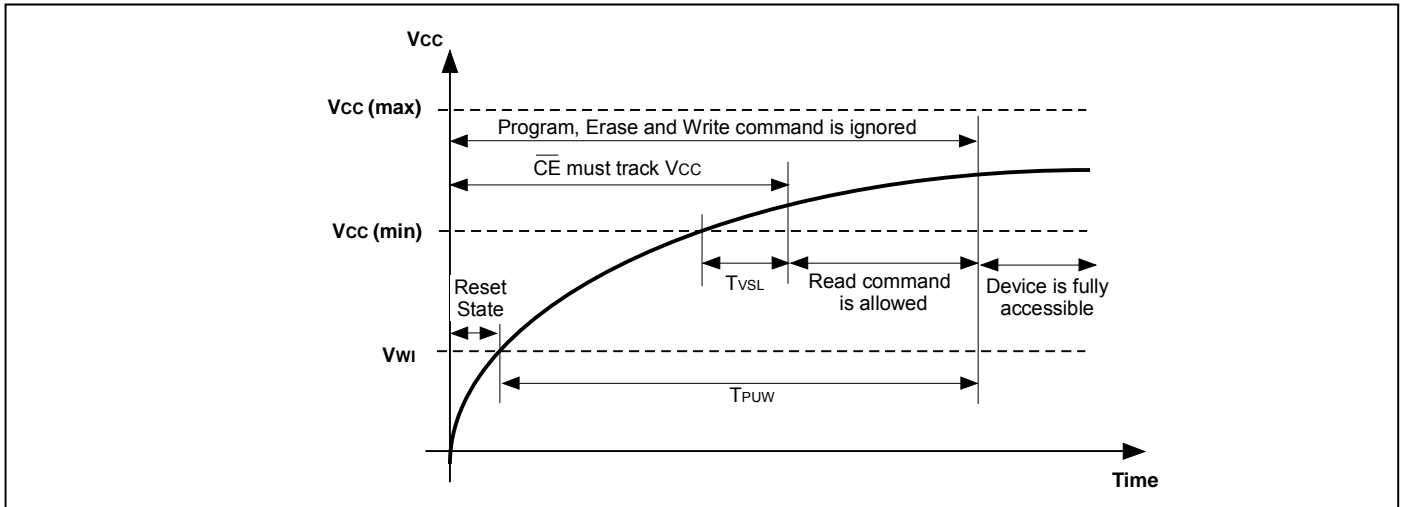

Figure 29: Power-Up Timing Diagram

Table 16: Power-Up Timing and V_{wi} Threshold

Parameter	Symbol	Min.	Max.	Unit
V _{cc} (min) to $\overline{\text{CE}}$ low	T _{VSL}	10		us
Time Delay before Write instruction	T _{PUW}	1	10	ms
Write Inhibit Threshold Voltage	V _{wi}	1	2.5	V

Note: These parameters are characterized only.

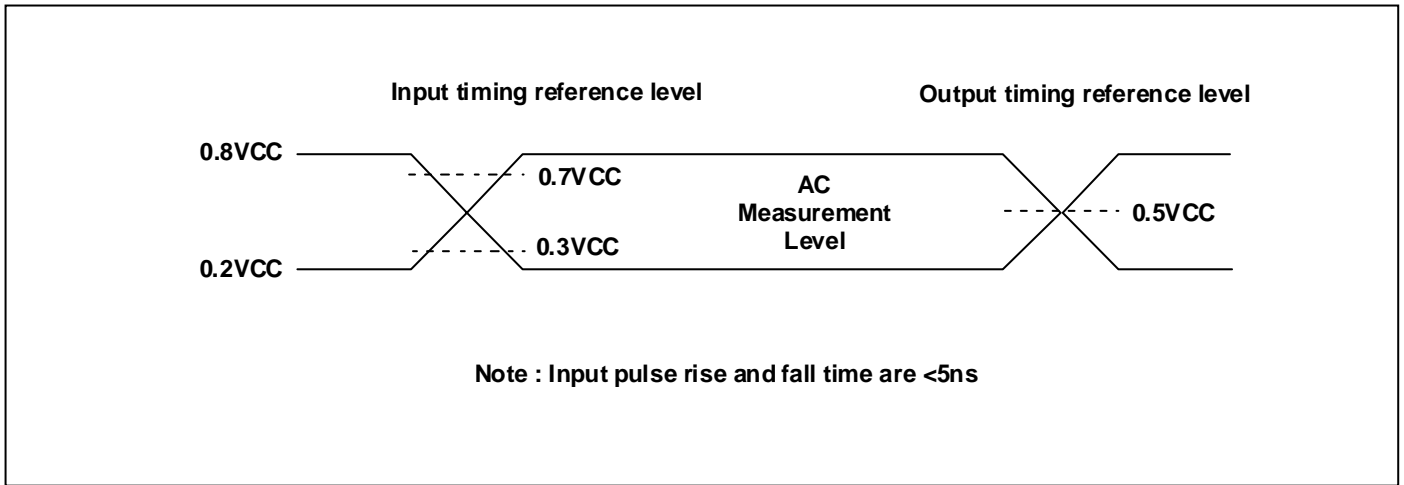

Figure 30: AC Input/Output Reference Waveforms

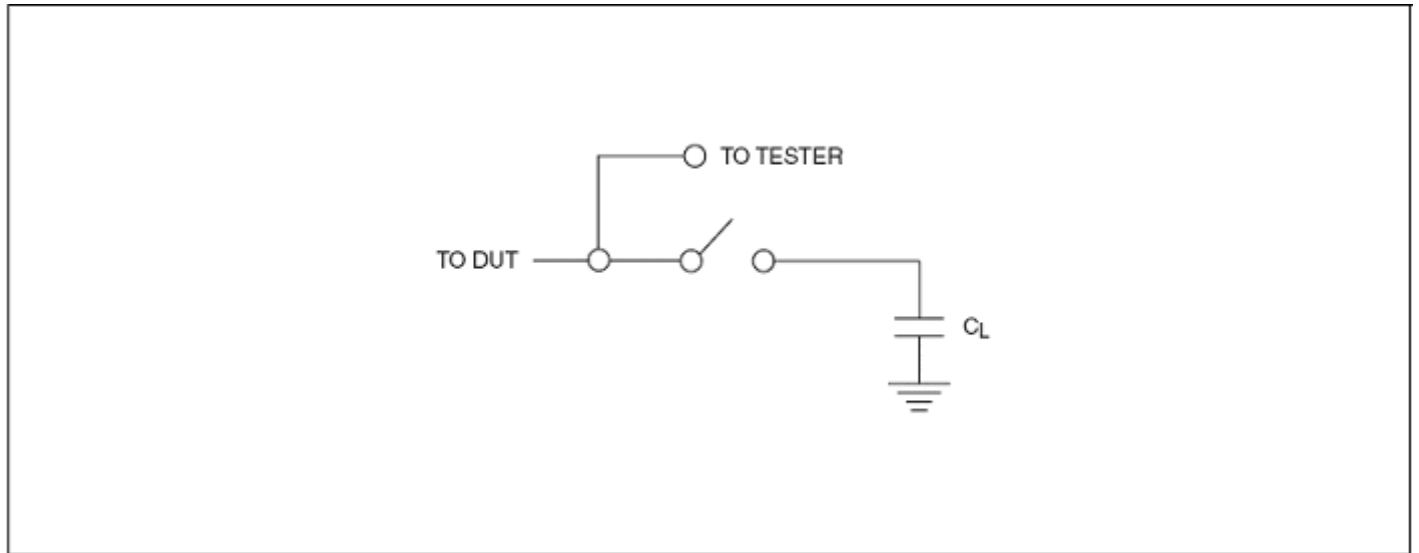
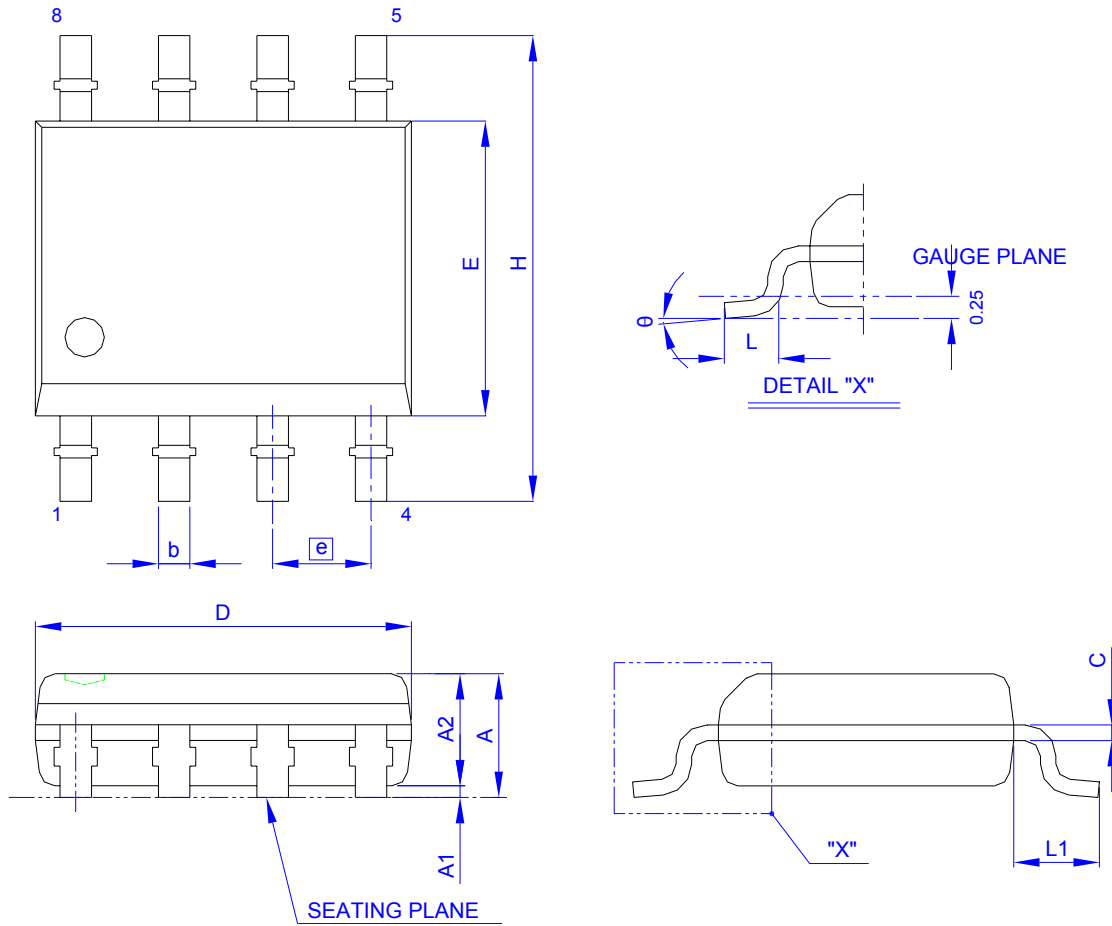

Figure 31: A Test Load Example

PACKAGING DIMENSIONS 8-LEAD SOIC (150 mil)



Symbol	Dimension in mm			Dimension in inch			Symbol	Dimension in mm			Dimension in inch		
	Min	Norm	Max	Min	Norm	Max		Min	Norm	Max	Min	Norm	Max
A	1.35	1.60	1.75	0.053	0.063	0.069	D	4.80	4.90	5.00	0.189	0.193	0.197
A ₁	0.10	0.15	0.25	0.004	0.006	0.010	E	3.80	3.90	4.00	0.150	0.154	0.157
A ₂	1.25	1.45	1.55	0.049	0.057	0.061	L	0.40	0.66	0.86	0.016	0.026	0.034
b	0.33	0.406	0.51	0.013	0.016	0.020	\square e	1.27 BSC			0.050 BSC		
c	0.19	0.203	0.25	0.0075	0.008	0.010	L ₁	1.00	1.05	1.10	0.039	0.041	0.043
H	5.80	6.00	6.20	0.228	0.236	0.244	θ	0°	---	8°	0°	---	8°

Controlling dimension : millimeter

PACKING DIMENSIONS

8-LEAD SOIC 200 mil (official name – 208 mil)

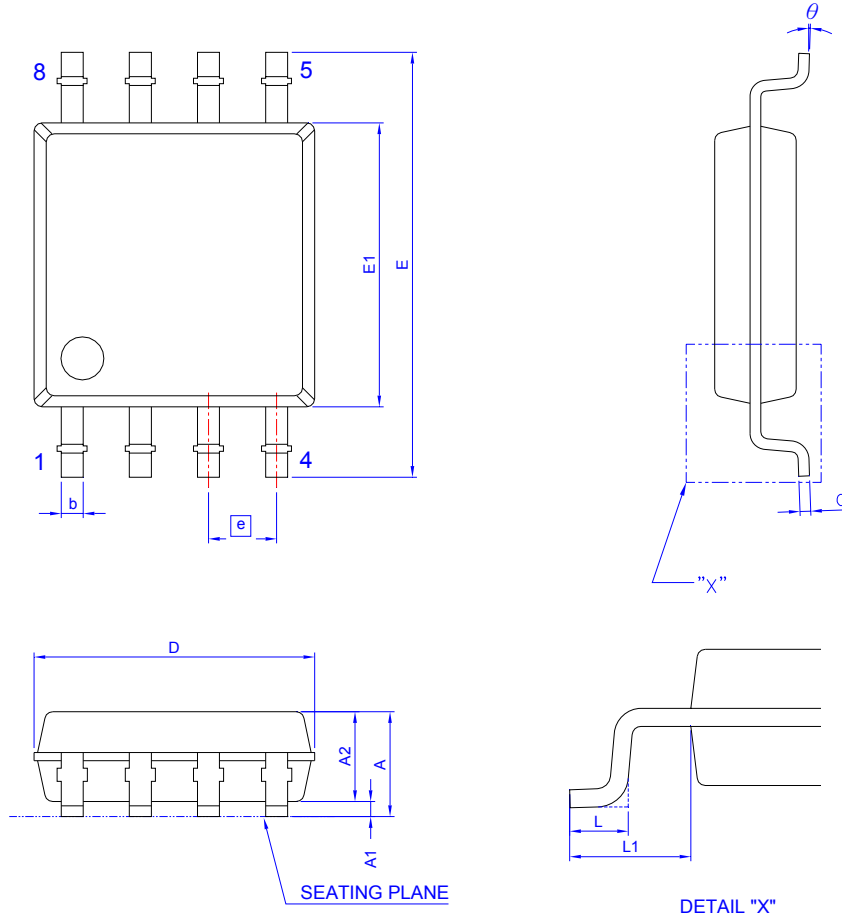

Symbol	Dimension in mm			Dimension in inch			Symbol	Dimension in mm			Dimension in inch		
	Min	Norm	Max	Min	Norm	Max		Min	Norm	Max	Min	Norm	Max
A	---	---	2.16	---	---	0.085	E	7.70	7.90	8.10	0.303	0.311	0.319
A ₁	0.05	0.15	0.25	0.002	0.006	0.010	E ₁	5.18	5.28	5.38	0.204	0.208	0.212
A ₂	1.70	1.80	1.91	0.067	0.071	0.075	L	0.50	0.65	0.80	0.020	0.026	0.032
b	0.36	0.41	0.51	0.014	0.016	0.020	e	1.27 BSC			0.050 BSC		
c	0.19	0.20	0.25	0.007	0.008	0.010	L ₁	1.27	1.37	1.47	0.050	0.054	0.058
D	5.13	5.23	5.33	0.202	0.206	0.210	θ	0°	---	8°	0°	---	8°

Controlling dimension : millimeter

PACKING DIMENSIONS

16-LEAD SOIC (300 mil)

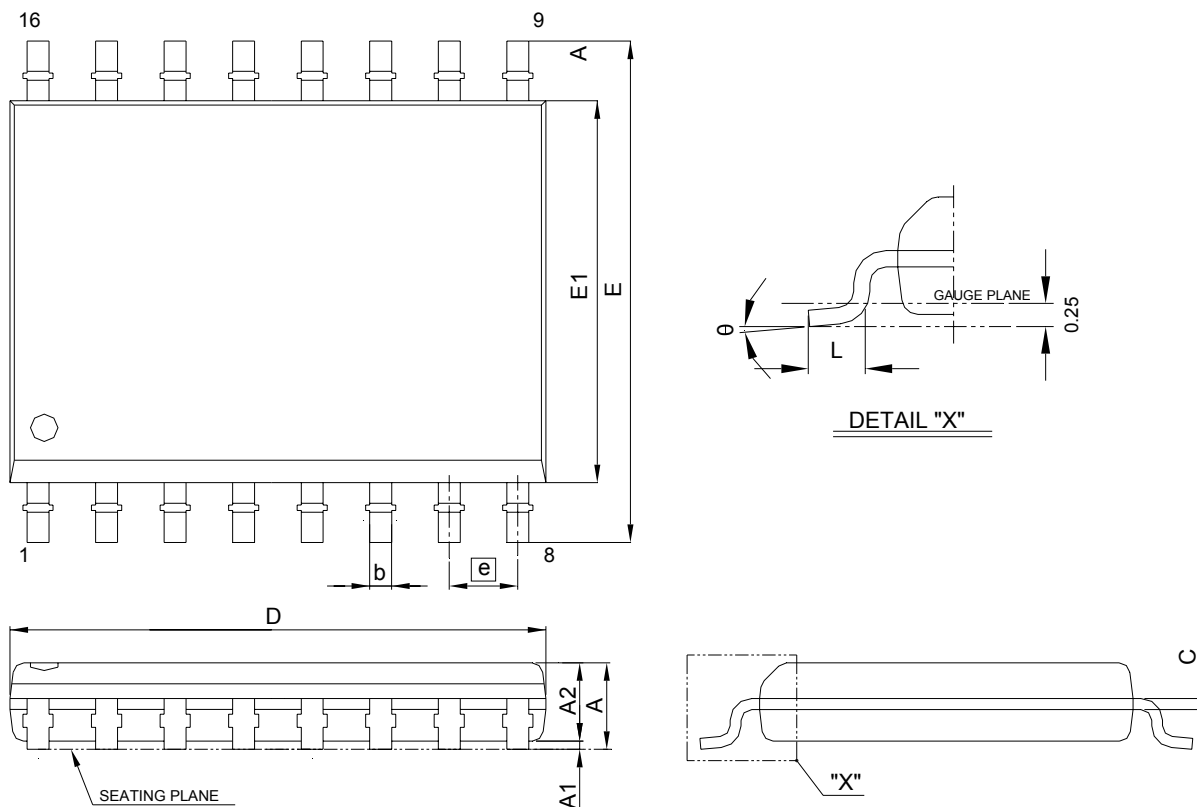

Symbol	Dimension in mm			Dimension in inch			Symbol	Dimension in mm			Dimension in inch		
	Min	Norm	Max	Min	Norm	Max		Min	Norm	Max	Min	Norm	Max
A	---	---	2.65	---	---	0.104	E	10.30 BSC			0.406 BSC		
A ₁	0.1	---	0.3	0.004	---	0.012	E ₁	7.50 BSC			0.295 BSC		
A ₂	2.05	---	---	0.081	---	---	L	0.40	---	1.27	0.016	---	0.050
b	0.31	---	0.51	0.012	---	0.020	θ	1.27 BSC			0.050 BSC		
c	0.20	---	0.33	0.008	---	0.013	θ	0°	---	8°	0°	---	8°
D	10.10	10.30	10.50	0.400	0.406	0.413							

Controlling dimension : millimeter

PACKING DIMENSIONS 8-PIN P-DIP (300 mil)

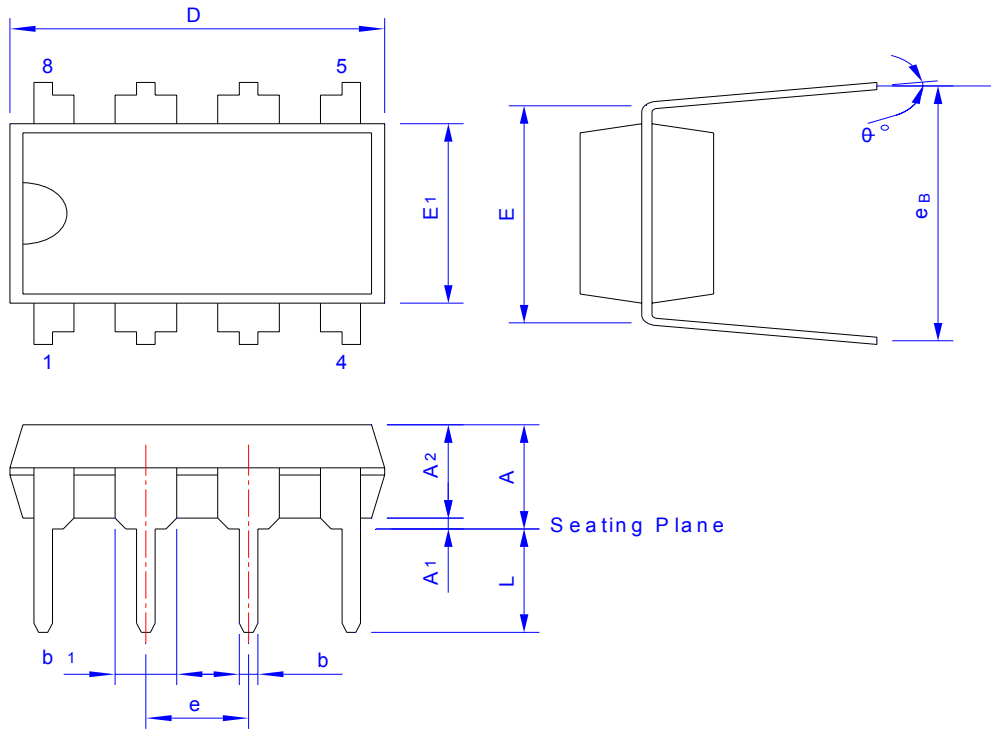

Symbol	Dimension in mm			Dimension in inch		
	Min	Norm	Max	Min	Norm	Max
A			5.00			0.21
A ₁	0.38			0.015		
A ₂	3.18	3.30	3.43	0.125	0.130	0.135
D	9.02	9.27	10.16	0.355	0.365	0.400
E	7.62 BSC.			0.300 BSC.		
E ₁	6.22	6.35	6.48	0.245	0.250	0.255
L	9.02	9.27	10.16	0.115	0.130	0.150
e	2.54 TYP.			0.100 TYP.		
e _B	8.51	9.02	9.53	0.335	0.355	0.375
b	0.46 TYP.			0.018 TYP.		
b ₁	1.52 TYP.			0.060 TYP.		
θ°	0°	7°	15°	0°	7°	15°

Controlling dimension : Inch.

PACKING DIMENSIONS

8-CONTACT WSON (6x5 mm)

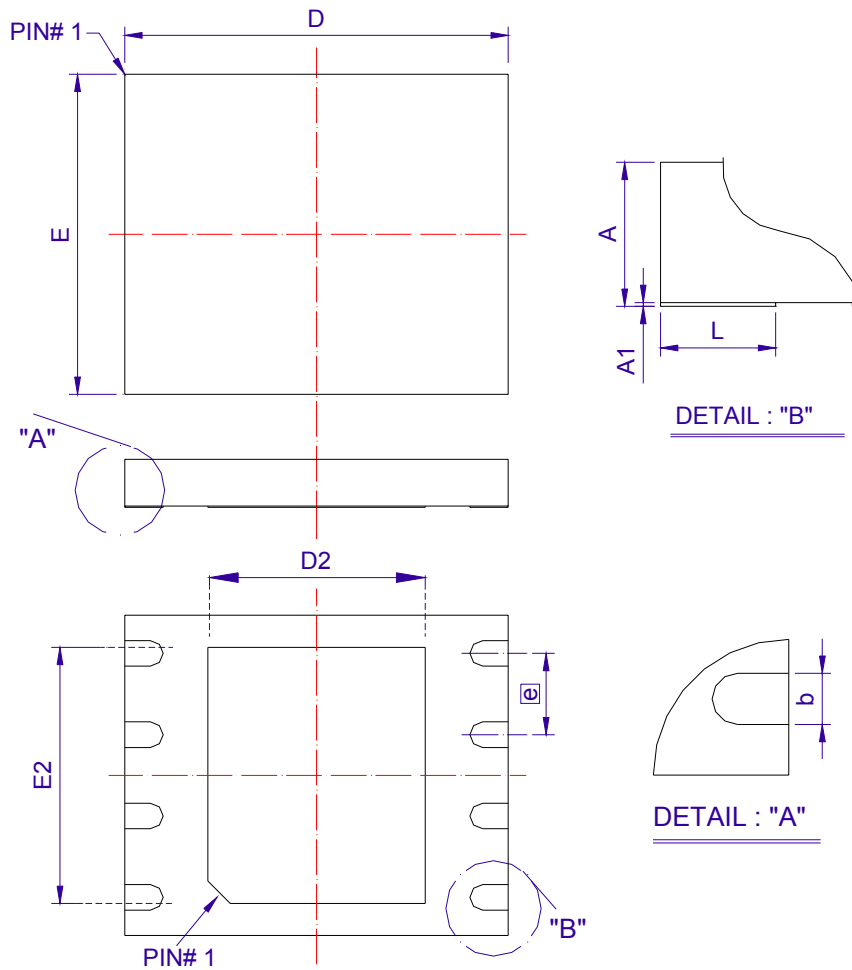

Symbol	Dimension in mm			Dimension in inch		
	Min	Norm	Max	Min	Norm	Max
A	0.70	0.75	0.80	0.028	0.030	0.031
A1	0.00	0.02	0.05	0.000	0.001	0.002
b	0.35	0.40	0.45	0.014	0.016	0.018
D	5.90	6.00	6.10	0.232	0.236	0.240
D2	2.50	2.60	2.70	0.098	0.102	0.106
E	4.90	5.00	5.10	0.193	0.197	0.201
E2	2.10	2.20	2.30	0.083	0.087	0.091
e	1.27 BSC			0.050 BSC		
L	0.55	0.60	0.65	0.022	0.024	0.026

Controlling dimension : millimeter

Revision History

Revision	Date	Description
0.1	2011.01.03	Original
0.2	2011.03.03	1. Ordering information : add 2S 2. Remove Byte program time 3. Modify WSON 6x5mm dimension : D2 2.50(min), 2.60(norm), 2.70(max) and E2, 2.10(min), 2.20(norm), 2.30(max)
0.3	2011.04.25	Modify the specification of I _{SB1} and I _{SB2}
1.0	2011.07.29	Delete Preliminary
1.1	2011.09.23	Modify normal read from 33MHz to 50MHz
1.2	2012.09.21	Modify Ambient Operating Temperature
1.3	2012.10.09	Correct the description of Block Protection, Block Protection Lock-Down and Erase Suspend

Important Notice

All rights reserved.

No part of this document may be reproduced or duplicated in any form or by any means without the prior permission of ESMT.

The contents contained in this document are believed to be accurate at the time of publication. ESMT assumes no responsibility for any error in this document, and reserves the right to change the products or specification in this document without notice.

The information contained herein is presented only as a guide or examples for the application of our products. No responsibility is assumed by ESMT for any infringement of patents, copyrights, or other intellectual property rights of third parties which may result from its use. No license, either express, implied or otherwise, is granted under any patents, copyrights or other intellectual property rights of ESMT or others.

Any semiconductor devices may have inherently a certain rate of failure. To minimize risks associated with customer's application, adequate design and operating safeguards against injury, damage, or loss from such failure, should be provided by the customer when making application designs.

ESMT's products are not authorized for use in critical applications such as, but not limited to, life support devices or system, where failure or abnormal operation may directly affect human lives or cause physical injury or property damage. If products described here are to be used for such kinds of application, purchaser must do its own quality assurance testing appropriate to such applications.