

High Efficiency, Step-Up Converter with EXT

Features

- Low Start-up Voltage: 1.0V
- 35µA Quiescent Supply Current in Switch-off mode
- <1µA Shutdown Current
- 90% Efficiency
- Excellent Load and Line Regulation Characteristics
- 350mΩ Internal MOSFET
- 450KHz Fixed Switching Frequency
- Small 6-Lead SOT-23 Package

Applications

- PDA
- DSC
- LCD Panel
- RF-Tags
- MP3
- Portable Equipment
- Wireless key board and mouse

Description

The EP4001 is a micropower, high efficiency, and low voltage step-up DC/DC converter intended for use in battery powered wireless applications. With the low start-up input voltage below 1V, the device is suitable for applications with 1 or 2 AA cells, providing up to 300mA output current at 3.3V output. The 35µA low quiescent current, zero shutdown current and high efficiency maintains long battery lifetime. A switching frequency of 450KHz minimizes solution footprint by allowing the use of small inductors and ceramic capacitors. The device is offered in a low profile (1mm) small 6-lead SOT-23 package. The current mode PWM design is optimized for stable and high efficiency operations over a wide range of load currents. With low resistance internal MOSFET switches, the EP4001 maintains high efficiency over a wide range of load current. In addition to its high efficiency at moderate and heavy loads, the EP4001 includes automatic PFM operation that improves efficiency of the power converter at light loads.

Typical Application

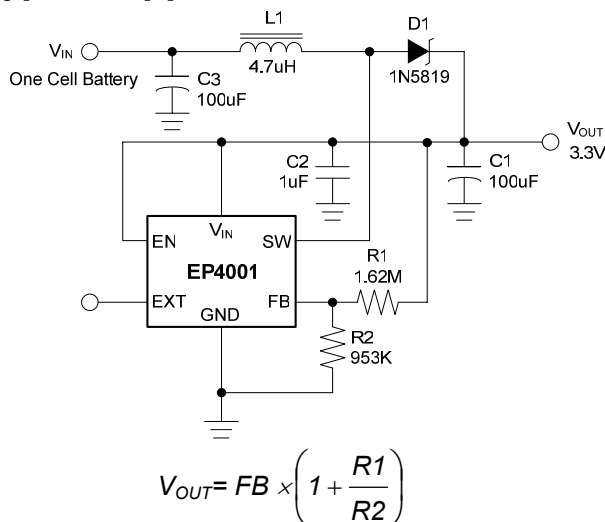
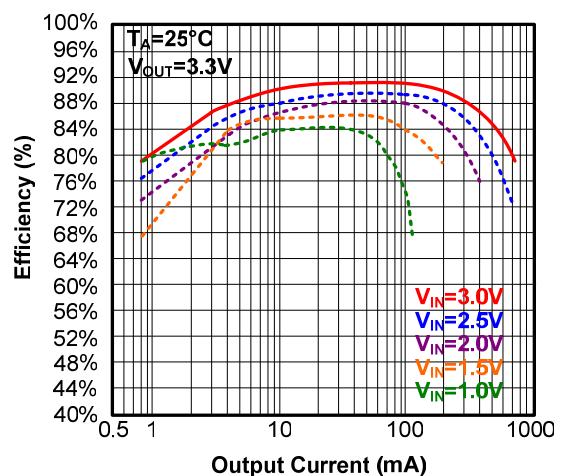
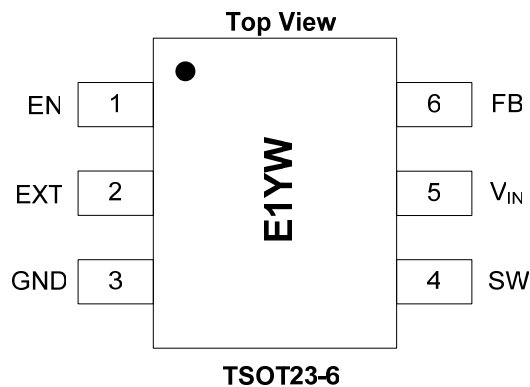

Figure 1-Basic application circuit with EP4001

Efficiency vs Output Current



Pin Assignment



Ordering Information

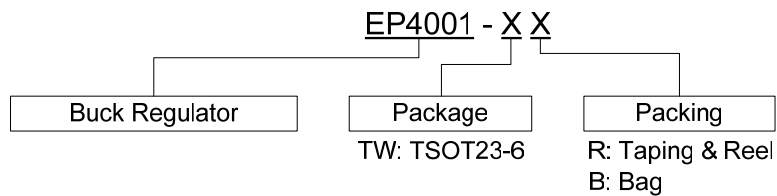

Pin Description

Pin	Name	Function
1	EN	Chip enable EP4001 gets into shutdown mode when EN pin set to low
2	EXT	Output pin for driving external NMOS.
3	GND	Ground.
4	SW	Pin for switching.
5	V _{IN}	Supply Input Pin. Must be closely decoupled to GND, Pin 2, with a 2.2μF or greater ceramic capacitor.
6	FB	Feedback input pin Internal reference voltage for the error amplifier is 1.25V

Thermal Resistance (Note 1)

Package	θ_{JA}	θ_{JC}
TSOT23-6	220°C/W	110°C/W

Absolute Maximum Rating (Note 2)

Symbol	Item	Rating	Units
V_{IN}	Input Supply Voltage	-0.3 ~ +6	V
V_{SW}	SW Pin Switch Voltage	-0.3 ~ +6	V
	Other I/O Pin Voltage	-0.3 ~ $V_{IN}+0.3$	V
I_{SW}	SW Pin Switch Current	2.5	A
I_{EXT}	EXT Pin Driver Current	150	mA
T_J	Junction Temperature (Note 3)	+125	°C
T_{STG}	Storage Temperature Range	-65 ~ +150	°C

Note 1: Thermal Resistance is specified with approximately 1 square of 1 oz cooper.

Note 2: Absolute Maximum ratings are threshold limit values that must not be exceeded even for an instant under any conditions. Moreover, such values for any two items must not be reached simultaneously. Operation above these absolute maximum ratings may cause degradation or permanent damage to the device. These are stress ratings only and do not necessarily imply functional operation below these limits.

Note 3: T_J is calculated from the ambient temperature T_A and power dissipation P_D according to the following formula: $T_J = T_A + (P_D) \times (220^\circ\text{C/W})$

Electrical Characteristics

($V_{IN} = 1.5V$, $V_{OUT}=3.3V$, $I_L = 0mA$, $T_A=25^{\circ}C$, Test Circuit Figure 2, unless otherwise specified)

Symbol	Parameter	Conditions	Min.	Typ.	Max.	Units
V_S	Start-up Voltage	$I_L=1mA$		0.85	1.05	V
	Operating V_{OUT} Range	V_{IN} pin voltage	2		4.2	V
I_Q	Quiescent Current (Shutdown Current)	EN pin = 0V, $V_{IN}=4.5V$		0.01	1	μA
I_Q	Quiescent Current (Switch-off Current)	$V_{IN}=6V$		35	50	μA
I_Q	Quiescent Current (Continuous Switching Current)	$V_{IN}=EN=3.3V$, $V_{FB}=GND$		0.4	0.6	mA
I_Q	Quiescent Current (No Load Current)			110		μA
V_{FB}	Feedback Reference Voltage	$T_A = +25^{\circ}C$	1.195	1.220	1.245	V
		$0^{\circ}C \leq T_A \leq 85^{\circ}C$	1.190	1.220	1.250	V
		$-40^{\circ}C \leq T_A \leq 85^{\circ}C$	1.183	1.220	1.257	V
F_S	Switching Frequency		380	450	520	KHz
D_{MAX}	Maximum Duty		85	90		%
	SW ON Resistance			0.03	1.1	Ω
I_{LIMIT}	Current Limit Setting			2		A
	EXT ON Resistance to V_{IN}			16		Ω
	EXT ON Resistance to GND			18		Ω
V_{OUT}	Output Voltage	$V_{IN}=1.5V$, $I_L=100mA$ $-40^{\circ}C \leq T_A \leq 85^{\circ}C$	3.200	3.300	3.400	V
V_{OUT}	Output Voltage	$V_{IN}=3.0V$, $I_L=300mA$ $-40^{\circ}C \leq T_A \leq 85^{\circ}C$	3.200	3.300	3.400	V
ΔV_{LINE}	Line Regulation	$V_{IN}=1V$ to $3V$, $I_L=1mA$		0.3		mV/V
ΔV_{LOAD}	Load Regulation	$V_{IN}=1.5V$, $I_L=1mA$ to $100mA$		0.4		mV/mA
ΔV_{LOAD}	Load Regulation	$V_{IN}=3.0V$, $I_L=1mA$ to $300mA$		0.4		mV/mA
	EN Pin Trip Level		0.4	0.8	1.2	V
T_S	Temperature Stability for V_{OUT}			110		ppm/ $^{\circ}C$
	Thermal Shutdown			165		$^{\circ}C$
	Thermal Shutdown Hysteresis			10		$^{\circ}C$

Typical Performance Characteristics

(Test Figure 2 above unless otherwise specified)

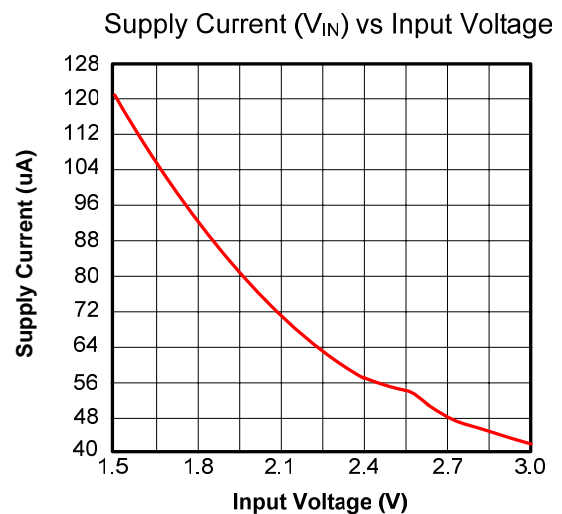
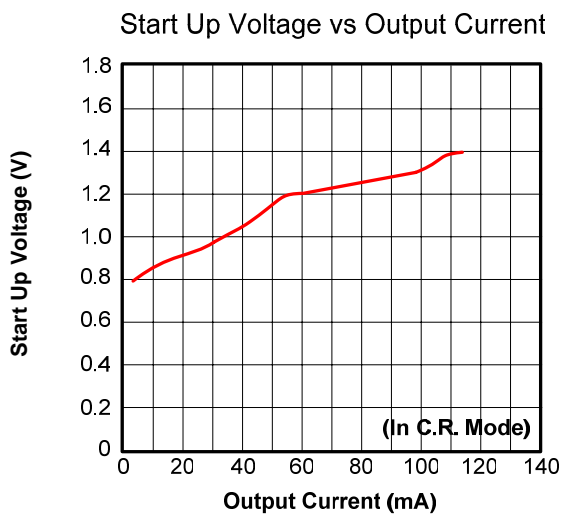
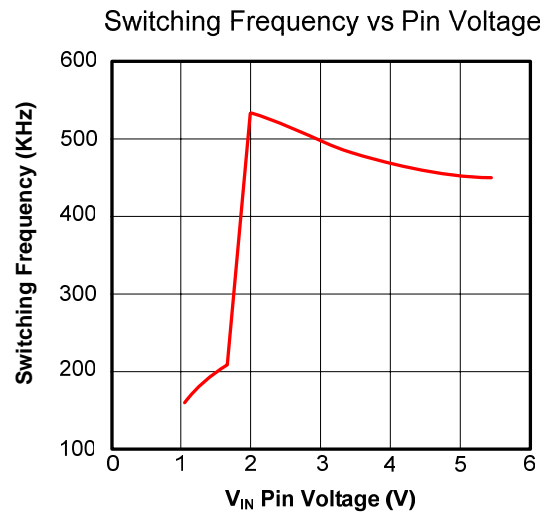
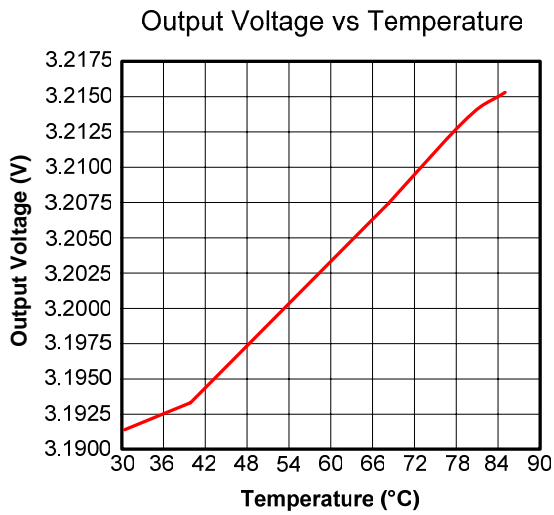
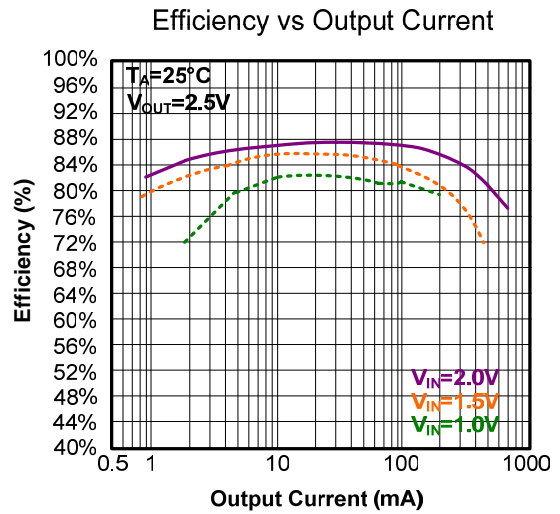
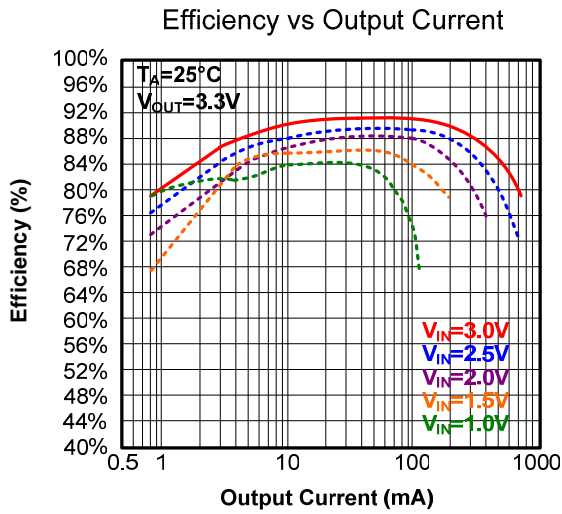

Functional Block Diagram

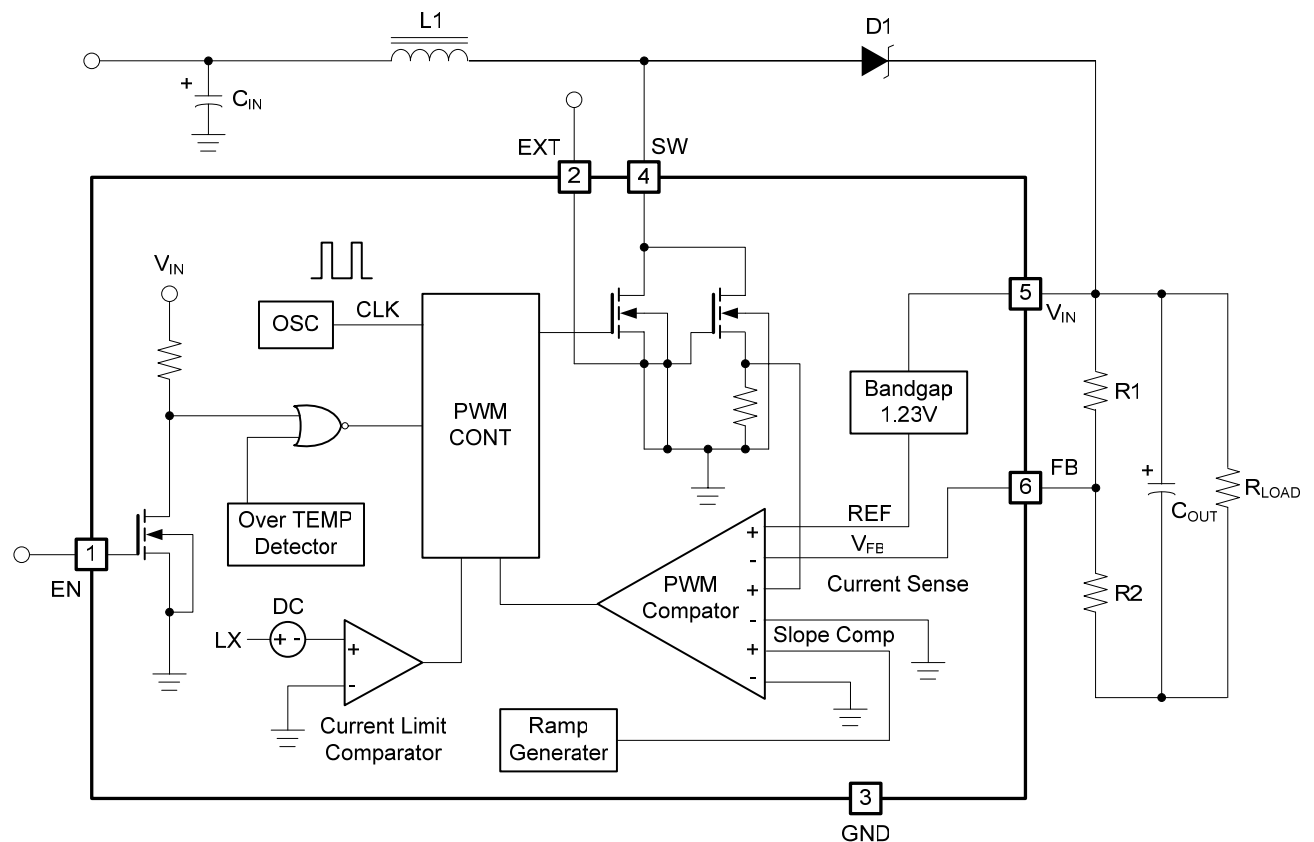

Figure 3-EP4001 Functional Block Diagram

Operation

The EP4001 is a current mode PWM boost converter with a fixed switching frequency at 450KHz. It is able to operate from an input voltage below 1V. With its low $R_{DS(ON)}$ internal MOSFET switch, this device maintains the high efficiency over a wide range of load current.

Low Voltage Start-Up

The EP4001 will start up with a typical V_{IN} voltage at 1V. The low voltage start-up circuitry controls the internal NMOS switch allowing the devices to start up into an output load. Once V_{OUT} exceeds 1.8V, the start-up circuitry is disabled and normal fixed frequency PWM operation is initiated. In this mode, the EP4001 operates independent of V_{IN} . The limiting factor for the application becomes the ability of the battery to supply sufficient energy to the output. Low Noise Fixed Frequency Operation Oscillator: The frequency of operation is internally set to 450KHz.

Low Noise Fixed Frequency Operation Oscillator

The frequency of operation is internally set to 450KHz.

Error Amp: The internal 1.22V reference voltage is compared to the voltage at the FB pin to generate an error signal at the output of the error amplifier. A voltage divider from V_{OUT} to ground programs the output according to the equation:

$$V_{OUT} = FB \times \left(1 + \frac{R1}{R2} \right)$$

Where $FB = 1.22V$

Due to device performance limitation, the EP4001 is limited to applications with output voltage less than 4.2V, until the problem is corrected at later date.

PWM Mode

Refer to Figure 3, functional block diagram. The main gain block is a comparator that sums four signals: feedback voltage, reference, current-sensing and slope compensation ramp. This direct-summing method approaches the ideal of cycle-by-cycle control of output voltage. Under heavy loads, the controller operates in full PWM mode. Every pulse from the oscillator sets the output latch and turns on the NMOS switch for a period determined by the duty factor and current limit.

PFM Mode Operation

Portable devices frequently spend extended time in low power or standby mode, only switching to high power mode when specific functions are enabled. Maintain high efficiency over a wide range of load current is critical for prolong battery life. In addition to its high efficiency at moderate and heavy loads, the EP4001 includes automatic PFM operation that improves efficiency of the converter at light load. PFM operation is initiated if the output load current falls below an internally programmed threshold. Once initiated, the PFM operation circuitry shuts down most of the device, only keeping alive the circuitry required to monitor the output voltage.

Applications Information

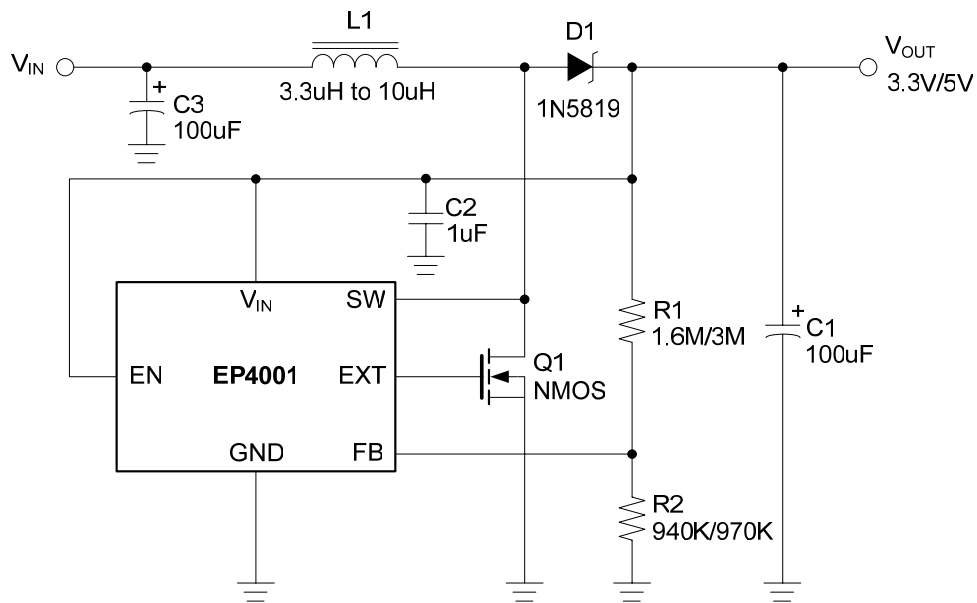

Figure 4-EP4001 for Higher Current Applications

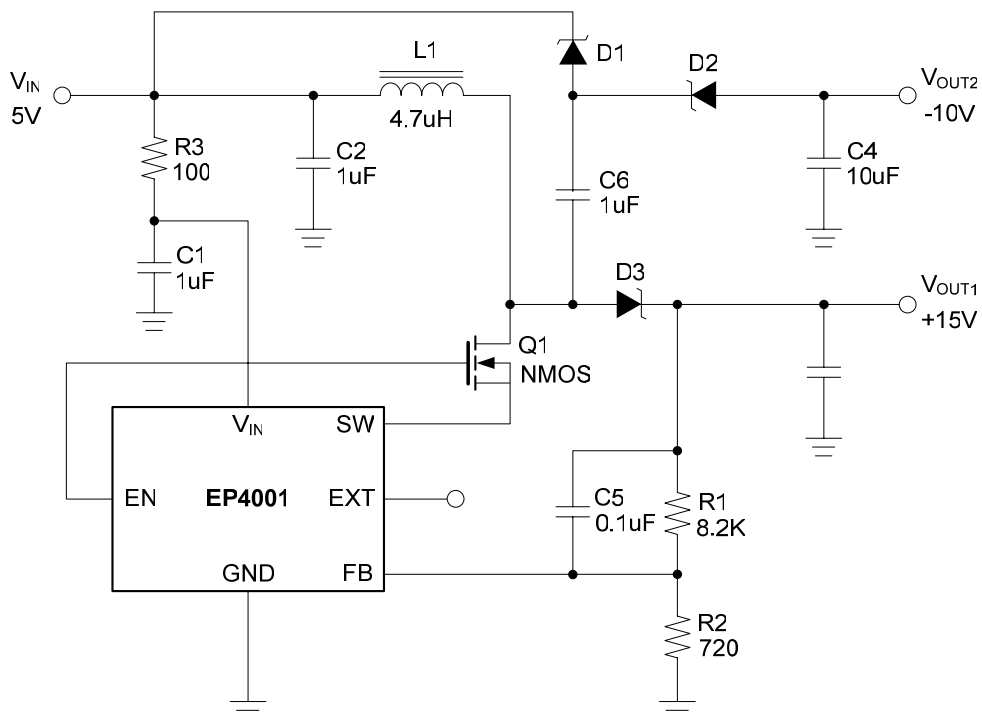

Figure 5-EP4001 for Multi-Output Applications

Inductor Selection

The EP4001 can utilize small surface mount and chip inductors operating at 450KHz switching frequency. The inductor current ripple is typically set for 20% to 40% of the maximum inductor current. The inductor should have low ESR (series resistance of the windings) to reduce the I^2R power losses, and must be able to handle the peak inductor current without saturating.

Output and Input Capacitor Selection

Low ESR (equivalent series resistance) capacitors should be used to minimize the output voltage ripple. Low ESR input capacitors reduce input switching noise and reduce the peak current drawn from the battery. The input decoupling capacitor should be located as close as possible to the device.

Output Voltage Setting

The output voltage of the switching regulator (V_{OUT}) is determined by (Eq.1)

Feedback Loop Design

The value selection for R1 and R2 is based on the trade-off between quiescent current consumption and interference immunity. Higher values for R1 and R2 will reduce the quiescent current, while Lower values for R1 and R2 has the advantage of a better noise immunity, and is less sensitive to other interferences. However, a resistor having a value higher than 5m Ω is not recommended. The noise immunity of the feedback loops can be improved by using a proper value of feed forward capacitor in parallel with R1. The value for this capacitor is between 0 to 33pF for feedback resistors of m Ω , and 10nF to 0.1 μ F for feedback resistors of tens to hundreds k Ω . Be aware that such kind of "high impedance feedback Loops" is sensitive to any interference, which require careful layout and avoid any interference.

Layout Guide

1. The power traces, which are consisted of GND trace, the SW trace and the V_{IN} trace should be kept short, direct and wide.
2. Keep the switching node, SW, away from the sensitive FB node.
3. Keep the distance between pin SW and L1 as close as possible, and no more than 3-4mm.
4. Keep the distance between capacitor C3 and L1 as close as possible, no more than 3-4mm.
5. Connect the (+) plate of C_{IN} to V_{IN} as closely as possible. This capacitor provides the AC current to the internal power MOSFETs.
6. Connect pin FB directly to the feedback resistors. The resistive divider R1/ R2 must be connected between the (+) plate of C_{OUT} and ground.
7. Keep the (-) plates of C_{IN} and C_{OUT} as close as possible.

Package Description

6pin TSOT-23

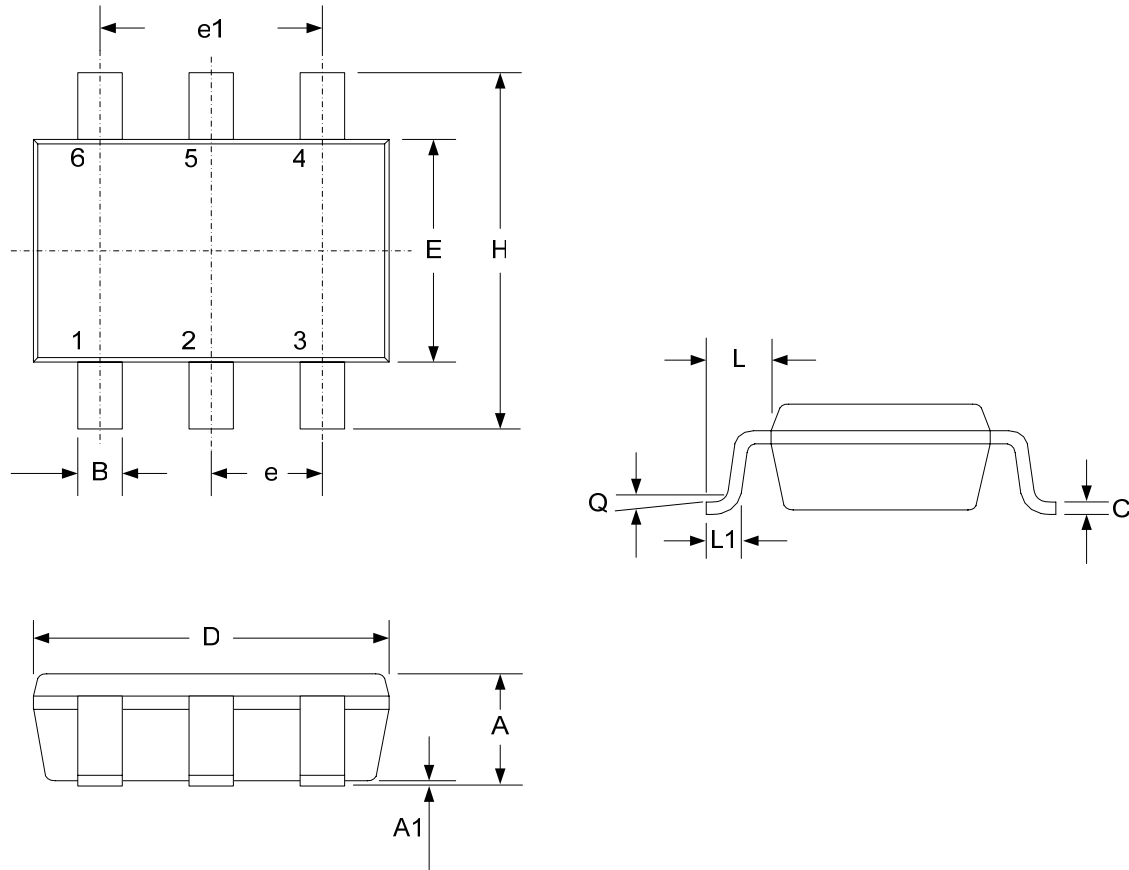

DIM	MILLIMETERS			INCHES		
	MIN.	NOM.	MAX.	MIN.	NOM.	MAX.
A	0.90	-	1.10	0.035	-	0.043
A1	0.01	-	0.13	0.0004	-	0.005
B	0.30	-	0.50	0.012	-	0.020
C	0.09	-	0.20	0.004	-	0.008
D	2.80	-	3.00	0.110	-	0.118
H	2.50	-	3.10	0.098	-	0.122
E	1.50	-	1.70	0.059	-	0.067
e	0.95 REF.			0.037 REF.		
e1	1.90 REF.			0.075 REF.		
L1	0.20	-	0.55	0.008	-	0.022
L	0.35	-	0.80	0.014	-	0.031
Q	0°	-	10°	0°	-	10°