

150 KHz, 3A Asynchronous Step-down Converter

Features

- Output Voltage: 3.3V, 5V, 12V and Adjustable Output Version
- Adjustable Version Output Voltage Range, 1.23V to 37V $\pm 4\%$
- 150KHz $\pm 15\%$ Fixed Switching Frequency
- Voltage Mode Asynchronous PWM Control
- Thermal-shutdown and Current-limit Protection
- ON/OFF Shutdown Control Input
- Operating Voltage can be up to 40V
- Output Load Current: 3A
- Low Power Standby Mode
- Built-in on Chip Switching Transistor
- TO263-5L and TO220-5L Packages

Applications

- Simple High-efficiency Step-down Regulator
- On-card Switching Regulators
- Positive to Negative Converter

Description

The EP3101 series are monolithic integrated circuits that provide all the active functions for a step-down DC/DC converter, capable of driving a 3A load without additional transistor component. Requiring a minimum number of external components, the board space can be saved easily. The external shutdown function can be controlled by TTL logic level and then come into standby mode. The internal compensation makes feedback control have good line and load regulation without external design. Regarding protected function, thermal shutdown is to prevent over temperature operating from damage, and current limit is against over current operating of the output switch.

The EP3101 series operates at a switching frequency of 150KHz thus allowing smaller sized filter frequency switching regulators. Other features include a guaranteed $\pm 4\%$ tolerance on output voltage under specified input voltage and output load conditions, and $\pm 15\%$ on the oscillator frequency. The output version includes fixes 3.3V, 5V, 12V, and an adjustable type. The packages are available in a standard 5-lead TO-220(T) package and a 5-lead TO-263(U)..

Typical Application

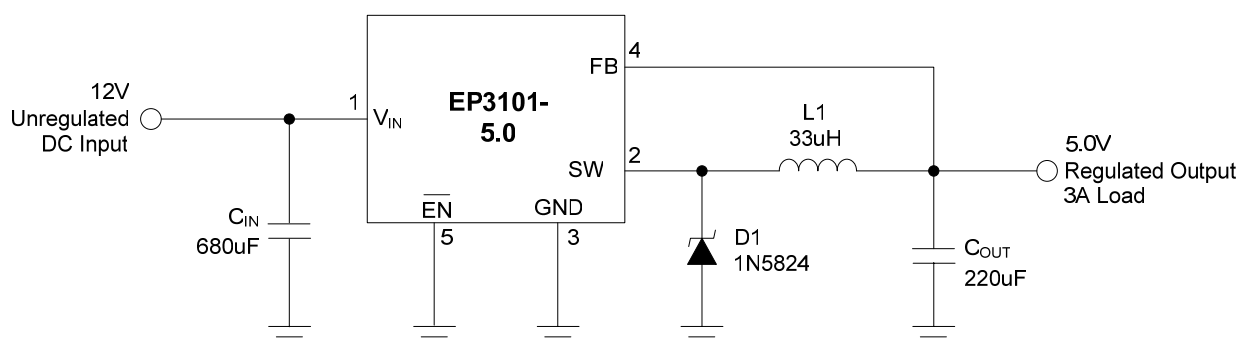

Pin Assignment

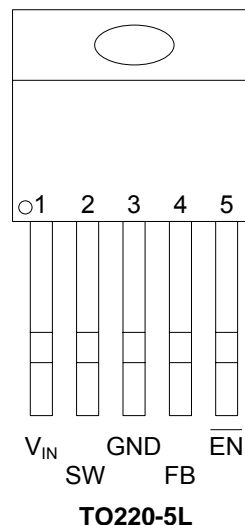
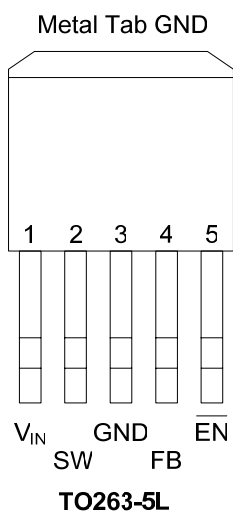

Ordering Information

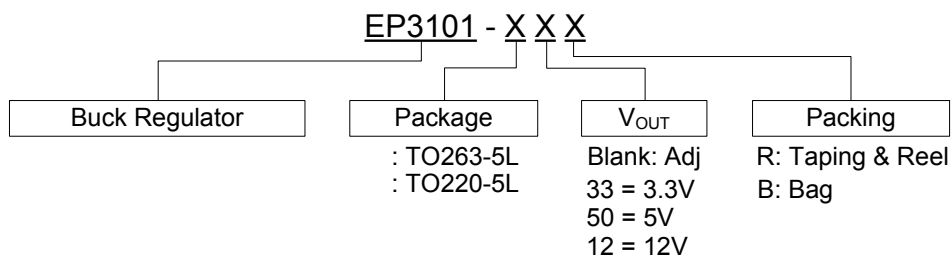

Pin Description

Pin	Name	Function
1	V _{IN}	This is the positive input supply for the IC switching regulator. A suitable input bypass capacitor must be present at this pin to minimize voltage transients and to supply the switching currents needed by the regulator.
2	SW	Internal switch. The voltage at this pin switches between (+V _{IN} -V _{SAT}) and approximately-0.5V, with a duty cycle of approximately V _{OUT} /V _{IN} . To minimize coupling to sensitive circuitry, the PC board copper area connected to this pin should be kept a minimum.
3	GND	Circuit ground.
4	FB	Senses the regulated output voltage to complete the feedback loop.
5	EN	Low enable. Allows the switching regulator circuit to be shutdown using logic level signals thus dropping the total input supply current to approximately 150uA. Pulling this pin below a threshold voltage of approximately 1.3V turns the regulator on, and pulling this pin above 1.3V (up to a maximum of 40V) shuts the regulator down. If this shutdown feature is not needed, the EN pin can be wired to the ground pin or it can be left open, in either case the regulator will be in the ON condition.

Absolute Maximum Rating (Note 1)

Symbol	Item	Rating	Units
V _{IN}	Input Supply Voltage	+45	V
V _{EN}	EN Pin Input Voltage	-0.3 ~ +25	V
V _{FB}	Feedback Pin Voltage	-0.3 ~ +25	V
V _{OUT}	Output Voltage to Ground	-1	V
V _{OP}	Operating Voltage	+4.5 ~ +25	V
P _D	Power Dissipation	Internally Limited	W
T _{OP}	Operating Temperature Range	-40 ~ +125	°C
T _{STG}	Storage Temperature Range	-65 ~ +150	°C

Electrical Characteristics (Note 2)

Unless otherwise specified, V_{IN}=12V for 3.3V, 5V, adjustable version and V_{IN}=24V for the 12V version.

I_{LOAD}=0.5A

Symbol	Parameter		Conditions	Min.	Typ.	Max.	Units
I _{FB}	Feedback Bias Current		V _{FB} =1.3V (Adjustable version only)		40	60 100	nA
F _{OSC}	Oscillator Frequency			127 110	150	173 173	KHz
V _{SAT}	Saturation Voltage		I _{OUT} =3A no outside circuit V _{FB} =0V force driver on		1.3	1.4 1.5	V
DC	Max. Duty Cycle (ON)		V _{FB} =0V force driver on		100		%
	Min. Duty Cycle (OFF)		V _{FB} =12V force driver off		0		
I _{CL}	Current Limit		Peak Current no outside circuit V _{FB} =0V force driver on	3.6	4.0	5.5 6.5	A
I _L	Output=0	Output Leakage Current	No outside circuit V _{FB} =12V fore driver off			200	μA
	Output=-1		V _{IN} =40V		2	30	
I _Q	Quiescent Current		V _{FB} =12V force driver off		5	10	mA
I _{STBY}	Standby Quiescent Current		EN pin=5V V _{IN} =40V		150	250 300	μA
V _{IL}	EN Pin Logic Input Threshold Voltage		Low (regulator ON)		1.3	0.6	V
V _{IH}			High (regulator OFF)	2.0			
I _H	EN Pin Logic Input Current		V _{LOGIC} =2.5V (OFF)		15	25	μA
I _L	EN Pin Input Current		V _{LOGIC} =0.5V (ON)		0.02	5	
θ _{JC}	Thermal Resistance		TO220-5L	Junction to Case		2.5	°C/W
			TO263-5L		3.5		
θ _{JA}	Thermal Resistance with Copper Area of Approximately 3in ²		TO220-5L	Junction to Ambient		28	°C/W
			TO263-5L		23		

Note 1: Absolute Maximum Ratings are those values beyond which the life of a device may be impaired.

Note 2: 100% production test at +25°C. Specifications over the temperature range are guaranteed by design and characterization.

Electrical Characteristics (Continued)

Symbol	Parameter		Conditions	Typ.	Limit	Units
V_{FB}	Output Feedback	EP3101-ADJ	4.5V< V_{IN} <40V 0.2A< I_{LOAD} <3A V_{OUT} programmed for 3V	1.23	1.193/1.18 1.267/1.28	V V_{MIN} V_{MAX}
η	Efficiency					
V_{OUT}	Output Voltage	EP3101-3.3V	4.75V< V_{IN} <40V 0.2A< I_{LOAD} <3A	3.3	3.168/3.135 3.432/3.465	V V_{MIN} V_{MAX}
η	Efficiency					
V_{OUT}	Output Voltage	EP3101-5V	7V< V_{IN} <40V 0.2A< I_{LOAD} <3A		4.8/4.75 5.2/5.25	V V_{MIN} V_{MAX}
η	Efficiency					
V_{OUT}	Output Voltage	EP3101-12V	15V< V_{IN} <40V 0.2A< I_{LOAD} <3A		11.52/11.4 12.48/12.6	V V_{MIN} V_{MAX}
η	Efficiency					

P.S. Specifications with boldface type are for full operating temperature range, the other type are for $T_J=25^{\circ}C$.

Typical Performance Characteristics

Normalized Output Voltage

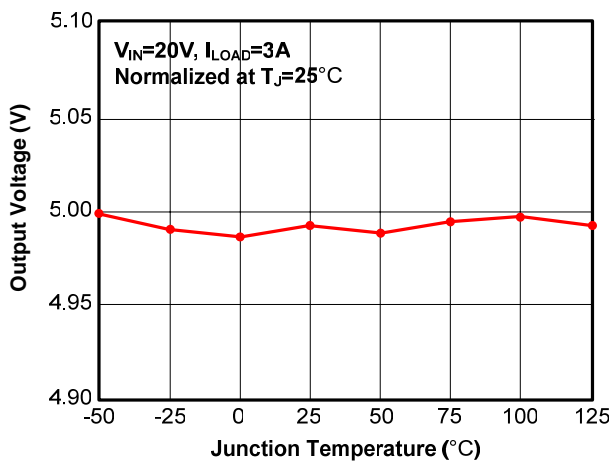

Switch Current Limit

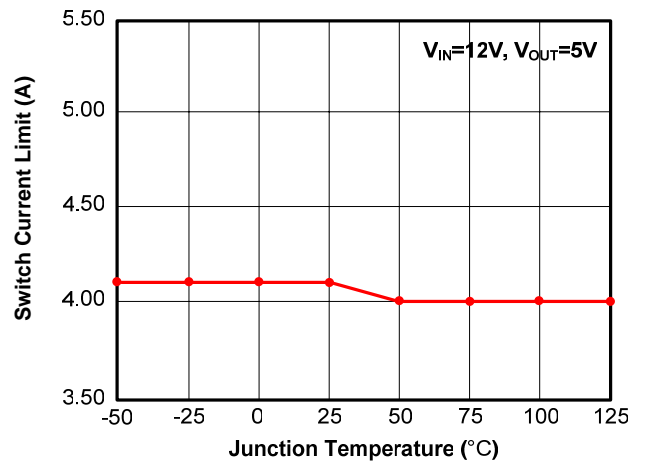

Efficiency

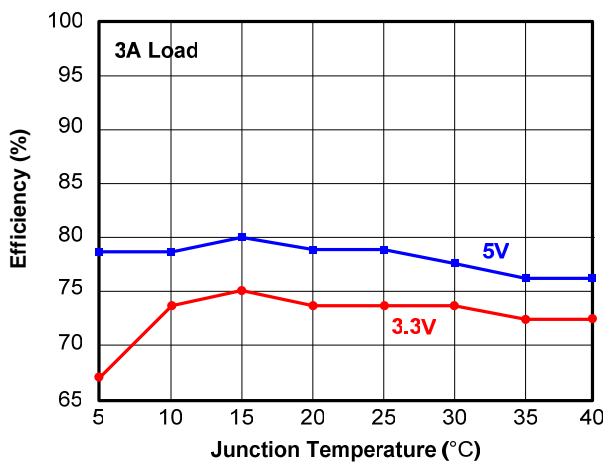

Switch Saturation Voltage

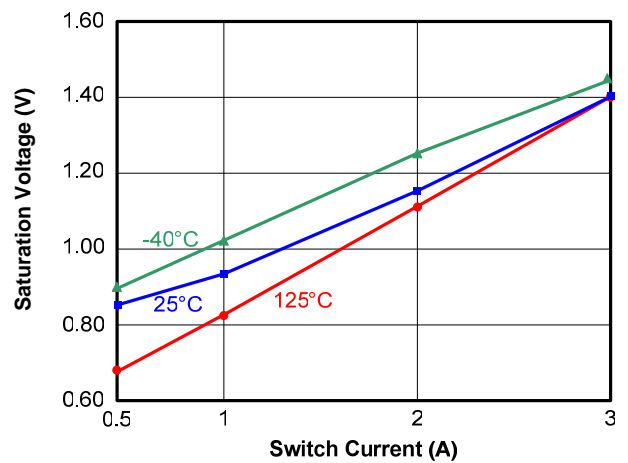

Minimum Operating Supply Voltage

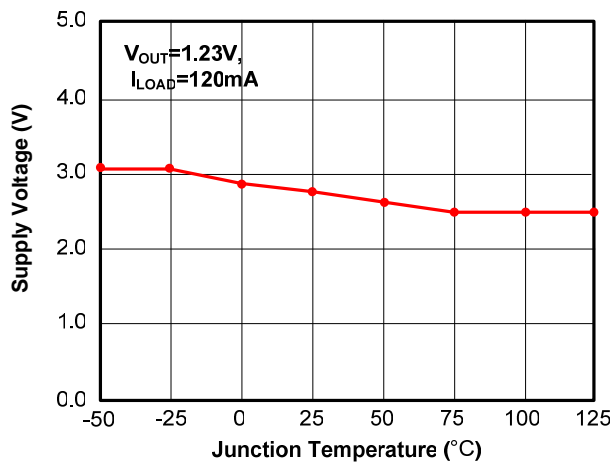

ON/OFF Threshold Voltage

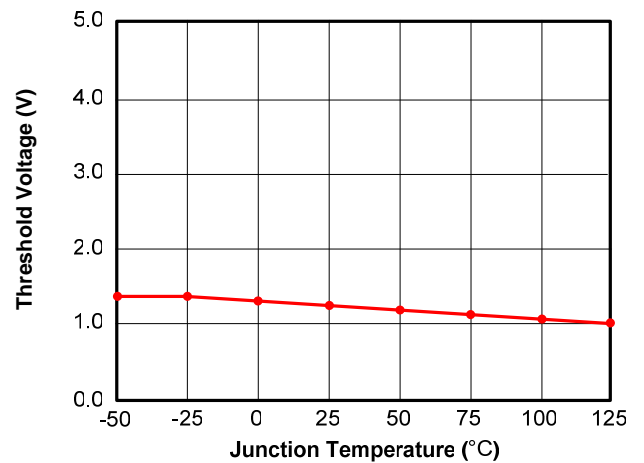

Typical Performance Characteristics (Continued)

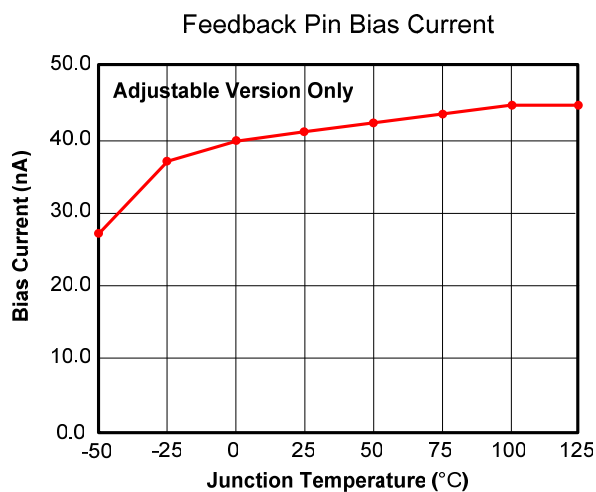
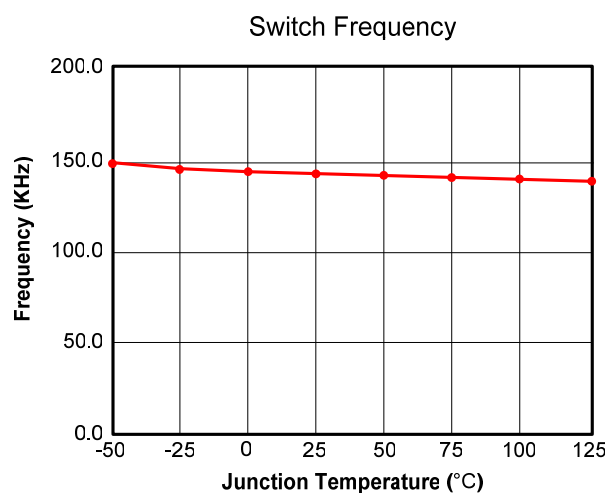
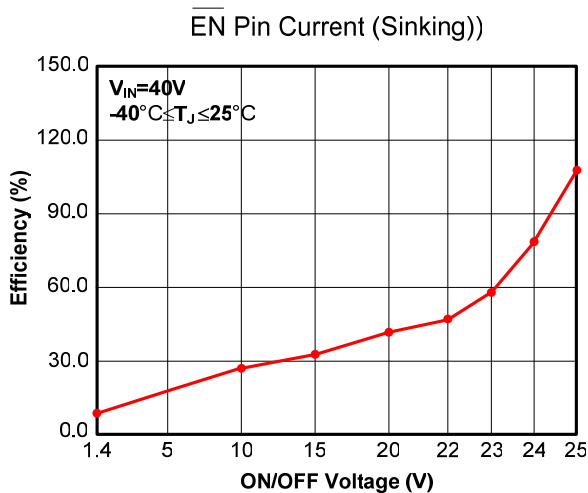
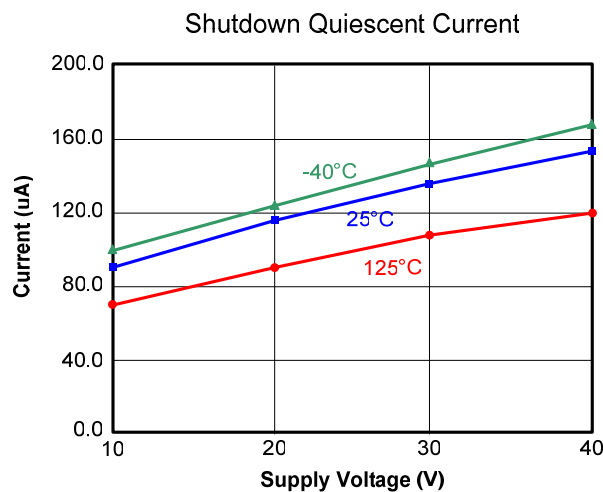
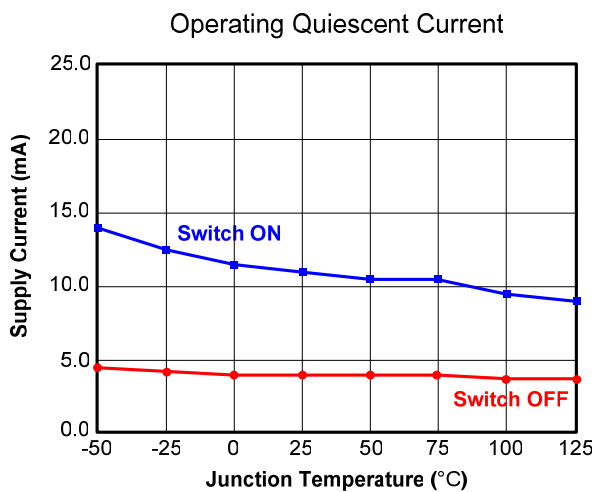

Functional Block Diagram

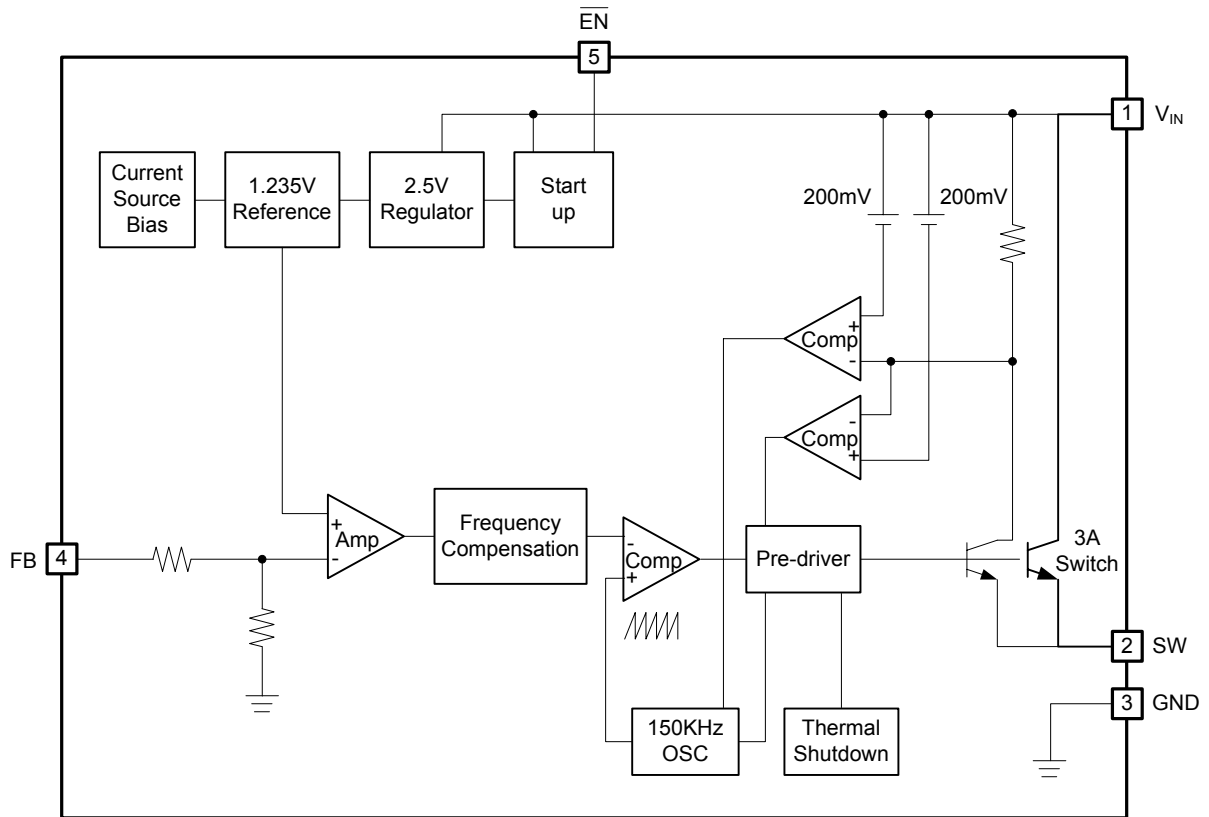

Applications Information

(1) Fixed Type Circuit

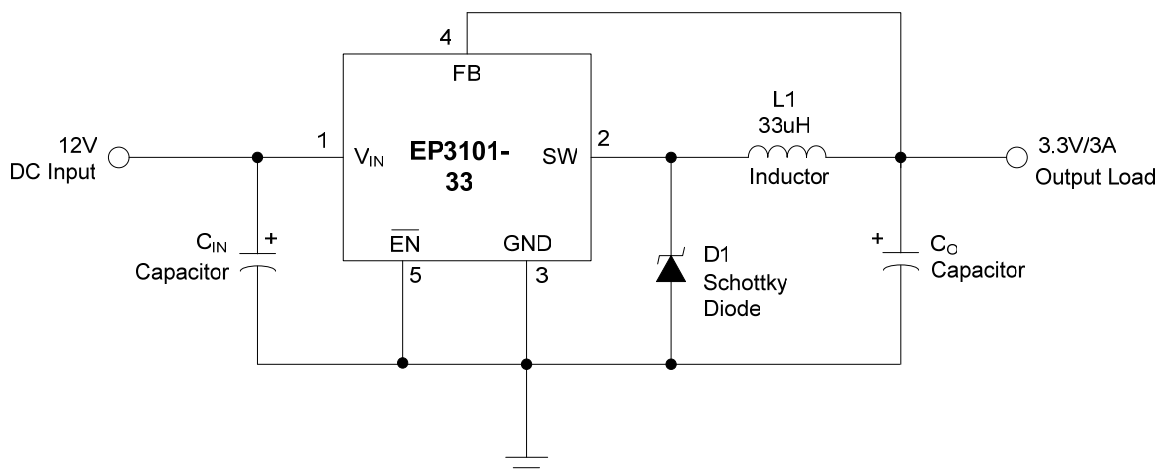

Applications Information (Continued)

(2) Adjustable Type Circuit

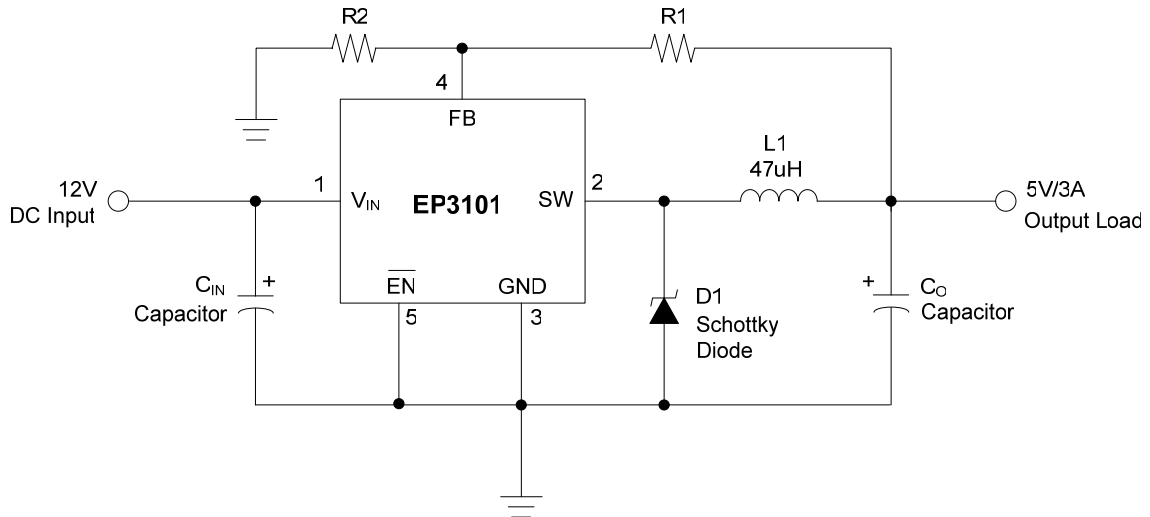

$$V_{OUT} = V_{FB} \times \left(1 + \frac{R1}{R2} \right)$$

$$V_{FB} = 1.23V$$

$$R2 = 1K \sim 3K$$

(3) Delay Start Circuit

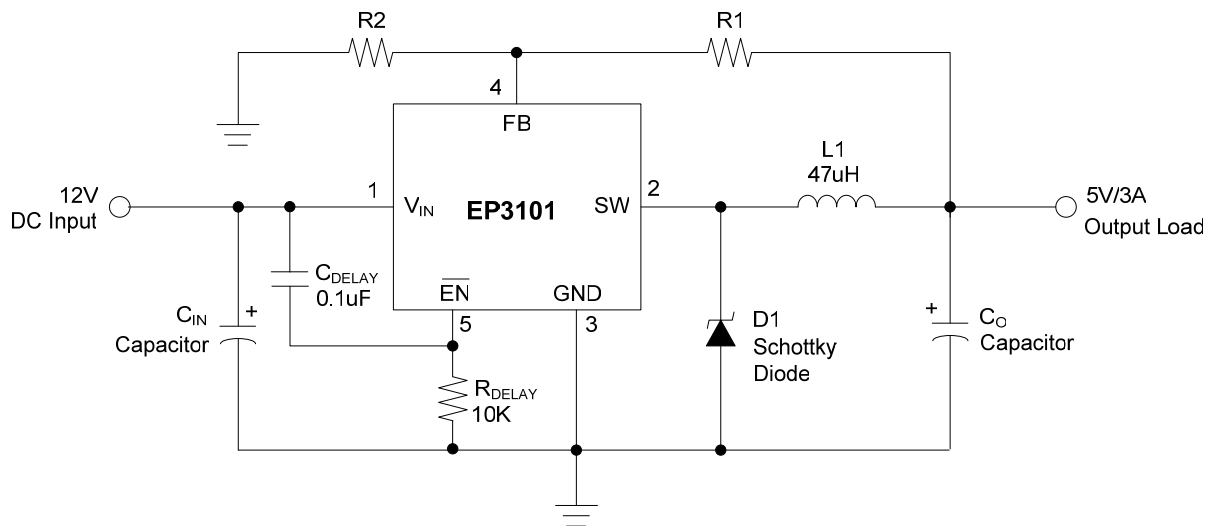

Buck Regulator Design Procedure

Given:

V_{OUT} = Regulated Output Voltage (3.3V, 5V or 12V)

$V_{IN(max)}$ = Maximum DC Input Voltage

$I_{LOAD(max)}$ = Maximum Load Current

F = Switching Frequency (Fixed at a nominal 150KHz)

1. Output Capacitor Selection (C_{OUT})

A low ESR (Equivalent Series Resistance) electrolytic capacitors between 82 μ F and 820 μ F and low ESR solid tantalum capacitors between 10 μ F and 470 μ F provide the best results. This capacitor should be located close to the IC using short capacitor leads and short copper traces. Do not use capacitors larger than 820 μ F. The capacitor voltage rating for electrolytic capacitors should be at least 1.5 times greater than the output voltage.

2. Catch Diode Selection (D1)

The catch diode current rating must be at least 1.3 times greater than the maximum load current. Also, if the power supply design must withstand a continuous output short, the diode should have a current rating equal to the maximum current limit of the EP3101. The reverse voltage rating of the diode should be at least 1.25 times the maximum input voltage. This diode must have short reverse recovery time and must be located close to the EP3101 using short leads and short printed circuit traces. Because of their fast switching speed and low forward voltage drop, Schottky diodes provide the best performance and efficiency, and should be the first choice, especially in low output voltage applications. Ultra-fast recovery diodes typically have reverse recovery times of 50ns or less.

3. Input Capacitor (C_{IN})

A low ESR aluminum or tantalum bypass capacitor is needed to prevent large voltage transients from appearing at the input. In addition, the RMS current rating of the input capacitor should be selected to be at least 1/2 the DC load current. The capacitor manufacturer's data sheet must be checked to assure that this current rating is not exceeded. For aluminum electrolytic, the capacitor voltage rating should be approximately 1.5 times the maximum input voltage.

4. Programming Output Voltage (Selecting R1 and R2, as shown in Adjustable Type Circuit)

Use the following formula to select the appropriate resistor values.

$$V_{OUT} = V_{REF} \times \left(1 + \frac{R1}{R2} \right) \text{ where } V_{REF} = 1.23V$$

Select a value for R2 between 240 Ω and 1.5K Ω . The lower resistor values minimize noise pickup in the sensitive feedback pin. (For the lowest temperature coefficient and the best stability with time, use 1% metal film resistors.)

5. Inductor Selection (L1)

Calculate the inductor Volt • microsecond constant E • T (V • μ s), from the following formula:

$$E \cdot T = (V_{IN} - V_{OUT} - V_{SAT}) \cdot \frac{V_{OUT} + V_D}{V_{IN} - V_{SAT} + V_D} \cdot \frac{1000}{150KHz} \text{ (V} \cdot \mu\text{s)}$$

where V_{SAT} = internal switch saturation voltage = 1.16V and V_D = diode forward voltage drop = 0.5V
On the horizontal axis selects the maximum load current.

Thermal Considerations

The EP3101 is available in two packages, a 5-pin TO-220 and a 5-pin surface mount TO-263. The TO-220 package needs a heat sink under most conditions. The size of the heatsink depends on the input voltage, the output voltage, the load current and the ambient temperature. The EP3101 junction temperature rises above ambient temperature for a 3A load and different input and output voltages. The data for these curves was taken with the EP3101 (TO-220 package) operating as a buck switching regulator in an ambient temperature of 25°C (still air). These temperature rise numbers are all approximate and there are many factors that can affect these temperatures. Higher ambient temperatures require more heat sinking.

The TO-263 surface mount package tab is designed to be soldered to the copper on a printed circuit board. The copper and the board are the heat sink for this package and the other heat producing components, such as the catch diode and inductor. The PC board copper area that the package is soldered to should be at least 0.4 in², and ideally should have 2 or more square inches of 2 oz. Additional copper area improves the thermal characteristics, but with copper areas greater than approximately 6 in², only small improvements in heat dissipation are realized. If further thermal improvements are needed, double sided, multilayer PC board with large copper areas and/or airflow are recommended.

The EP3101 (TO-263 package) junction temperature rise above ambient temperature with a 2A load for various input and output voltages. This data was taken with the circuit operating as a buck switching regulator with all components mounted on a PC board to simulate the junction temperature under actual operating conditions. This curve can be used for a quick check for the approximate junction temperature for various conditions, but be aware that there are many factors that can affect the junction temperature. When load currents higher than 2A are used, double sided or multilayer PC boards with large copper areas and/or airflow might be needed, especially for high ambient temperatures and high output voltages.

For the best thermal performance, wide copper traces and generous amounts of printed circuit board copper should be used in the board layout. (Once exception to this is the output (switch) pin, which should not have large areas of copper.) Large areas of copper provide the best transfer of heat (lower thermal resistance) to the surrounding air, and moving air lowers the thermal resistance even further.

Package thermal resistance and junction temperature rise numbers are all approximate, and there are many factors that will affect these numbers. Some of these factors include board size, shape, thickness, position, location, and even board temperature. Other factors are, trace width, total printed circuit copper area, copper thickness, single or double-sided, multilayer board and the amount of solder on the board. The effectiveness of the PC board to dissipate heat also depends on the size, quantity and spacing of other components on the board, as well as whether the surrounding air is still or moving.

Furthermore, some of these components such as the catch diode will add heat to the PC board and the heat can vary as the input voltage changes. For the inductor, depending on the physical size, type of core material and the DC resistance, it could either act as a heat sink taking heat away from the board, or it could add heat to the board.

Delayed Startup

The circuit in Figure 1 uses the $\overline{\text{EN}}$ pin to provide a time delay between the time the input voltage is applied and the time the output voltage comes up (only the circuitry pertaining to the delayed start up is shown). As the input voltage rises, the charging of capacitor C1 pulls the $\overline{\text{EN}}$ pin high, keeping the regulator off. Once the input voltage reaches its final value and the capacitor stops charging, and resistor R2 pulls the $\overline{\text{EN}}$ pin low, thus allowing the circuit to start switching. Resistor R1 is included to limit the maximum voltage applied to the $\overline{\text{EN}}$ pin (maximum of 25V), reduces power supply noise sensitivity, and also limits the capacitor, C1, discharge current. When high input ripple voltage exists, avoid long delay time, because this ripple can be coupled into the $\overline{\text{EN}}$ pin and cause problems.

This delayed startup feature is useful in situations where the input power source is limited in the amount of current it can deliver. It allows the input voltage to rise to a higher voltage before the regulator starts operating. Buck regulators require less input current at higher input voltages.

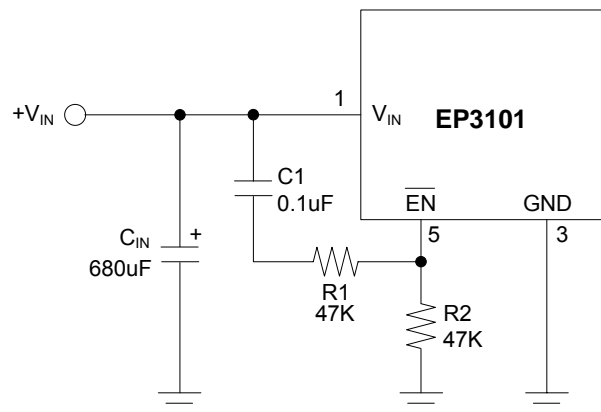
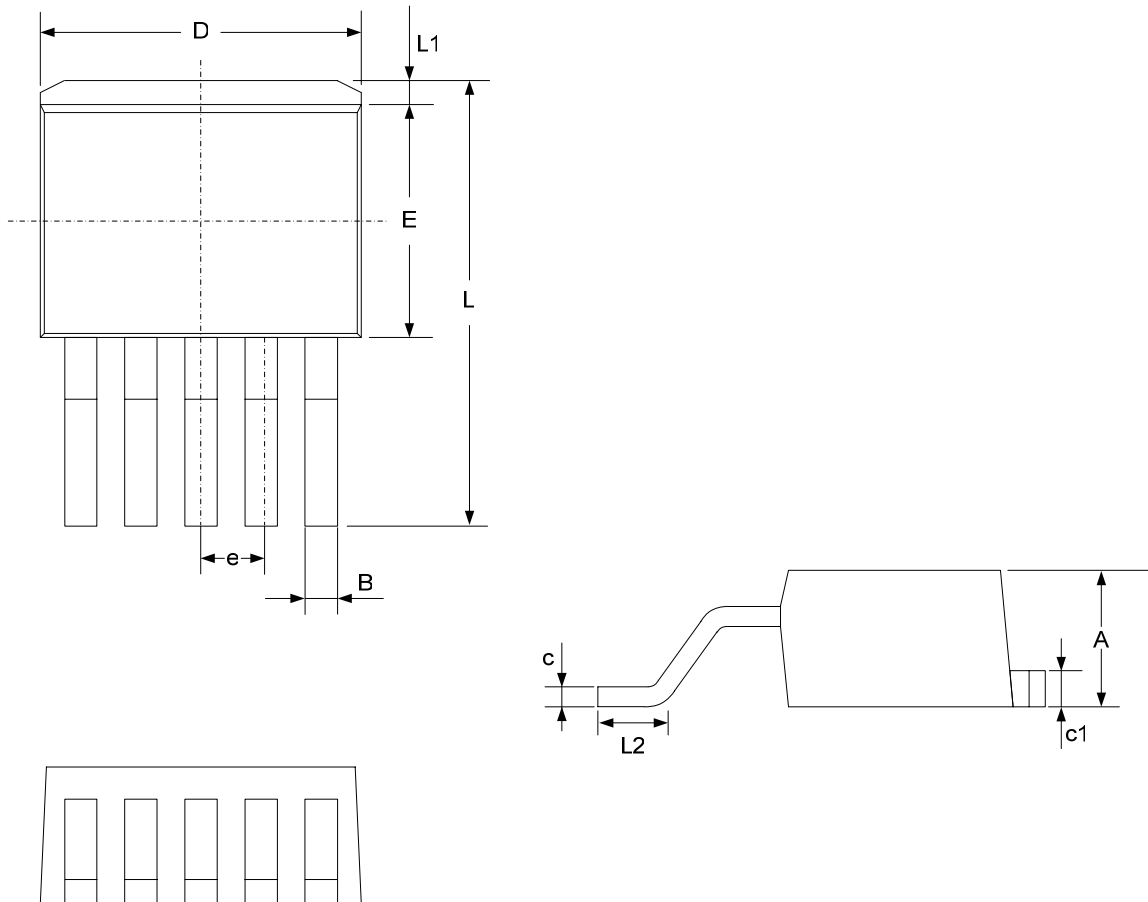

Figure 1-Delayed Startup

Package Description

TO263-5L



DIM	MILLIMETERS			INCHES		
	MIN.	NOM.	MAX.	MIN.	NOM.	MAX.
A	4.07	4.46	4.85	0.160	0.176	0.191
B	0.66	0.84	1.02	0.026	0.033	0.040
c	0.36	0.50	0.64	0.014	0.020	0.025
c1	1.14	1.27	1.40	0.045	0.050	0.055
D	9.78	10.16	10.54	0.385	0.400	0.415
E	8.65	9.15	9.65	0.341	0.360	0.380
e	1.57	1.71	1.85	0.062	0.068	0.073
L	14.61	15.24	15.88	0.575	0.600	0.625
L1	–	–	2.92	–	–	0.115
L2	2.29	2.54	2.79	0.090	0.100	0.110

Package Description (Continued)

TO220-5L

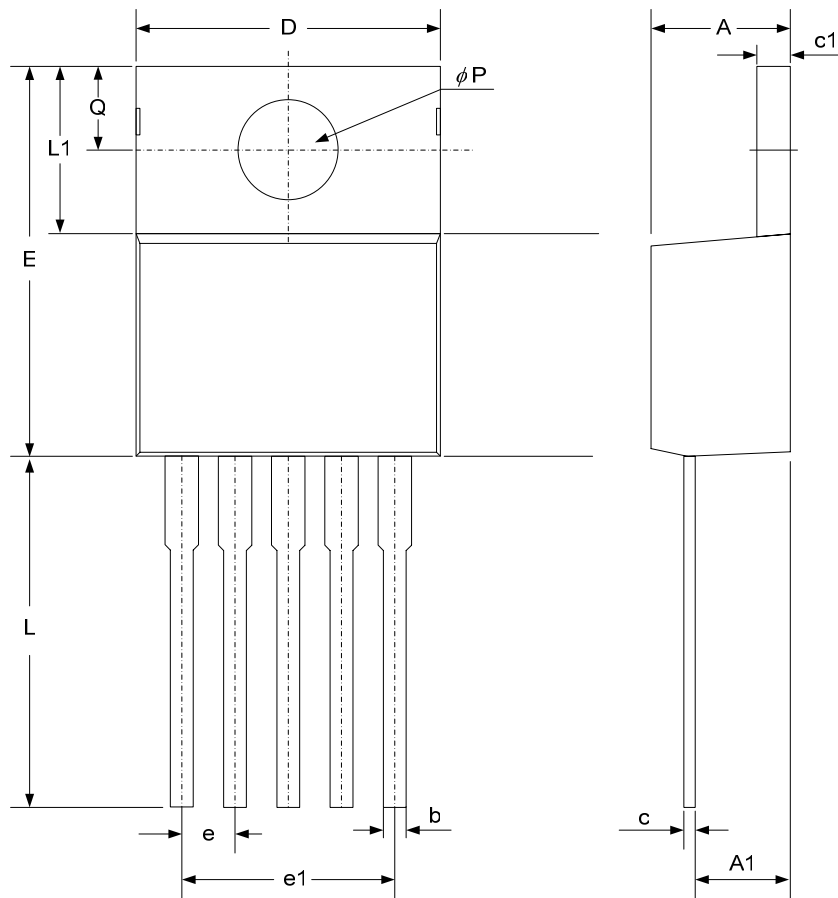

DIM	MILLIMETERS			INCHES		
	MIN.	NOM.	MAX.	MIN.	NOM.	MAX.
A	4.07	4.45	4.82	0.160	0.175	0.190
A1	2.29	2.74	3.18	0.090	0.108	0.125
b	0.76	0.89	1.02	0.030	0.035	0.040
c	0.36	0.50	0.64	0.014	0.020	0.025
c1	1.14	1.27	1.40	0.045	0.050	0.055
D	9.78	10.16	10.54	0.385	0.400	0.415
E	14.22	14.86	15.50	0.560	0.585	0.610
e	1.57	1.71	1.85	0.062	0.067	0.073
e1	6.68	6.81	6.93	0.263	0.268	0.273
L	13.21	13.97	14.73	0.520	0.550	0.580
L1	5.46	6.16	6.86	0.215	0.243	0.270
Q	2.54	2.73	2.92	0.100	0.107	0.115
ϕP	3.68	3.81	3.94	0.145	0.150	0.155