

1.5MHz, 600mA Synchronous Step-down Converter

Features

- High Efficiency: Up to 96%
- 1.5MHz Constant Switching Frequency
- 600mA Output Current at $V_{IN} = 3V$
- Integrated Main Switch and Synchronous Rectifier
- No Schottky Diode Required
- 2.5V to 5.5V Input Voltage Range
- Output Voltage as Low as 0.6V
- 100% Duty Cycle in Low Dropout Operation
- Low Quiescent Current: 300 μ A
- Slope Compensated Current Mode Control for Excellent Line and Load Transient Response
- Short Circuit Protection
- Thermal Fault Protection, <1uA Shutdown Current
- Space Saving 5-Pin Thin SOT23 package

Applications

- Cellular and Smart Phones
- Microprocessors and DSP Core Supplies
- Wireless and DSL Modems
- PDAs
- MP3 Players
- Digital Still and Video Cameras
- Portable Instruments

Description

The EP3001 is a 1.5MHz, constant frequency, slope compensated current mode PWM step-down converter. The device integrates a main switch and a synchronous rectifier for high efficiency without an external Schottky diode. It is ideal for powering portable equipment that runs from a single cell lithium-Ion (Li+) battery.

The EP3001 can supply 600mA of load current from a 2.5V to 5.5V input voltage. The output voltage can be regulated as low as 0.6V. The EP3001 can also run at 100% duty cycle for low dropout operation, extending battery life in portable system. Idle mode operation at light loads provides very low output ripple voltage for noise sensitive applications.

The EP3001 is offered in a low profile (1mm) 5-pin, thin SOT package, and is available in an adjustable version and fixed output voltage of 1.2V, 1.5V and 1.8V.

Typical Application

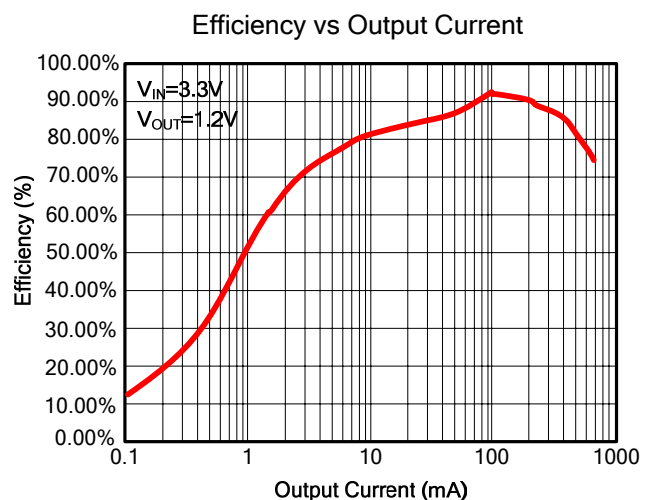
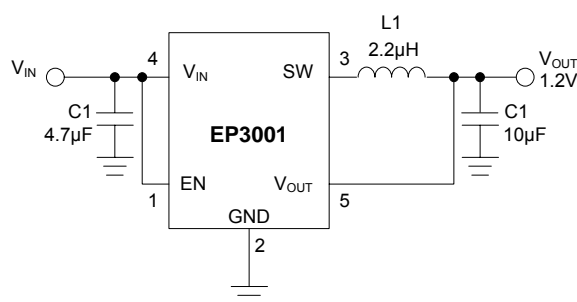
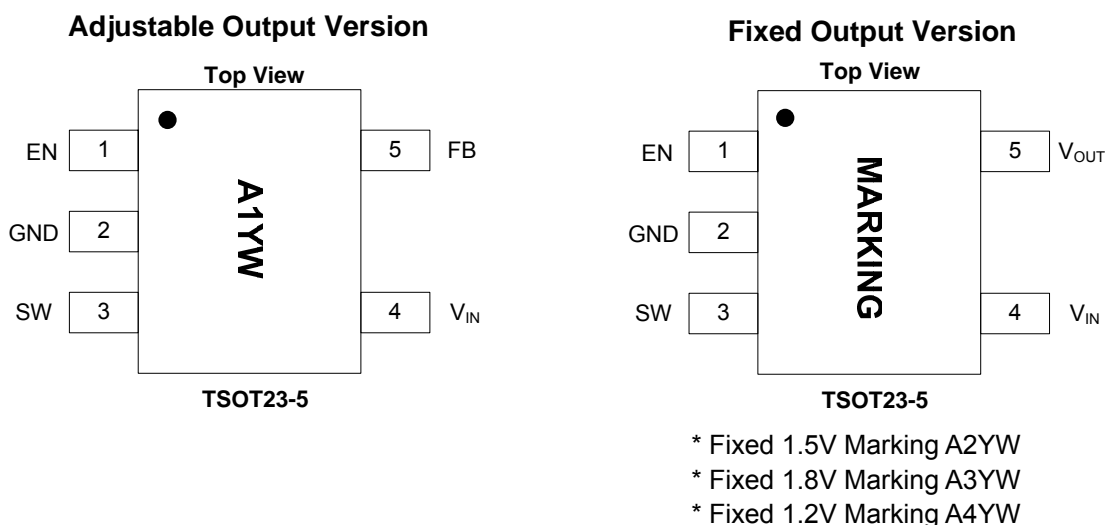
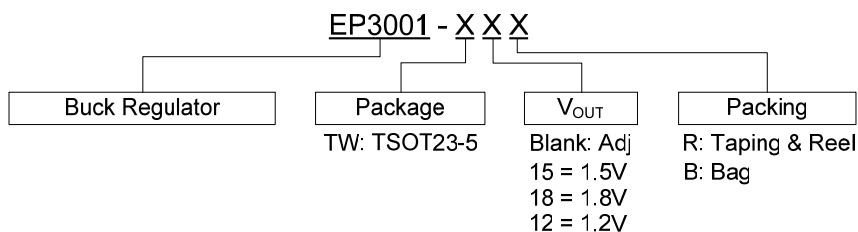

Figure 1-Basic application circuit with EP3001 fixed output version

Pin Assignment



Ordering Information



Pin Description

Pin	Name	Function
1	EN	Regulator Enable control input. Drive EN above 1.5V to turn on the part. Drive EN below 0.3V to turn it off. In shutdown, all functions are disabled drawing <1μA supply current. Do not leave EN floating.
2	GND	Ground
3	SW	Power Switch Output. It is the Switch node connection to Inductor. This pin connects to the drains of the internal P-Ch and N-Ch MOSFET switches.
4	V _{IN}	Supply Input Pin. Must be closely decoupled to GND, Pin 2, with a 2.2μF or greater ceramic capacitor.
5	FB/V _{OUT}	FB(EP3001-Adj): Feedback Input Pin. Connect FB to the center point of the external resistor divider. The feedback threshold voltage is 0.6V. V_{OUT}(EP3001-1.2/EP3001-1.5/EP3001-1.8): Output Voltage Feedback Pin. An internal resistive divider divides the output voltage down for comparison to the internal reference voltage.

Thermal Resistance (Note 1)

Package	θ_{JA}	θ_{JC}
TSOT23-5	220°C/W	110°C/W

Absolute Maximum Rating (Note 2)

Symbol	Item	Rating	Units
V_{IN}	Input Supply Voltage	-0.3 ~ +6	V
$V_{EN,FB}$	EN, FB Voltages	-0.3 ~ V_{IN}	V
V_{SW}	SW Voltages	-0.3 ~ $V_{IN}+0.3$	V
	P-Channel Switch Source Current(DC)	800	mA
	N-Channel Switch Sink Current(DC)	800	mA
	Peak SW Sink and Source Current	1.3	A
T_{OP}	Operating Temperature Range	-40 ~ +85	°C
T_J	Junction Temperature (Note 3)	+125	°C
T_{STG}	Storage Temperature Range	-65 ~ +150	°C
T_L	Lead Temperature (Soldering, 10s)	+300	°C

Note 1: Thermal Resistance is specified with approximately 1 square of 1 oz copper.

Note 2: Absolute Maximum Ratings are those values beyond which the life of a device may be impaired.

Note 3: T_J is calculated from the ambient temperature T_A and power dissipation PD according to the following formula: $T_J = T_A + (PD) \times (220^\circ\text{C/W})$

Electrical Characteristics (Note 4)

($V_{IN}=V_{EN}=3.6V$, $T_A=25$, unless otherwise noted.)

Symbol	Parameter	Conditions	Min.	Typ.	Max.	Units
V_{IN}	Input Voltage Range		2.5		5.5	V
I_S	Input DC Supply Current Active Mode Shutdown Mode	$V_{FB}=0.5V$ or $V_{OUT}=90\%$ $V_{FB}=0V$, $V_{IN}=4.2V$		300 0.1	400 1.0	μA μA
V_{FB}	Regulated Feedback Voltage	$T_A=+25^\circ C$	0.5880	0.6000	0.6120	V
		$T_A=0^\circ C \leq T_A \leq 85^\circ C$	0.5865	0.6000	0.6135	V
		$T_A=-40^\circ C \leq T_A \leq 85^\circ C$	0.5820	0.6000	0.6180	V
ΔV_{FB}	Reference Voltage Line Regulation	$V_{IN}=2.5V$ to $5.5V$		0.04	0.4	%/V
I_{FB}	Feedback Input Bias Current	$V_{FB}=0.65V$			± 30	nA
V_{OUT}	Regulated Output Voltage	EP3001-1.2, $-40^\circ C \leq T_A \leq 85^\circ C$	1.164	1.200	1.236	V
		EP3001-1.5, $-40^\circ C \leq T_A \leq 85^\circ C$	1.455	1.500	1.546	V
		EP3001-1.8, $-40^\circ C \leq T_A \leq 85^\circ C$	1.746	1.800	1.854	V
ΔV_{OUT}	Output Voltage Line Regulation	$V_{IN}=2.5V$ to $5.5V$		0.04	0.40	%
$V_{LOADREG}$	Output Voltage Load Regulation			0.5		%
I_{PK}	Peak Inductor Current	$V_{IN}=3V$, $V_{FB}=0.5V$ or $V_{OUT}=90\%$ Duty Cycle < 35%	0.75	1.00	1.25	A
f_{OSC}	Oscillator Frequency	$V_{FB}=0.6V$ or $V_{OUT}=100\%$	1.2	1.5	1.8	MHz
R_{PFET}	$R_{DS(ON)}$ of P-CH MOSFET	$I_{SW}=300mA$		0.40	0.50	Ω
R_{NFET}	$R_{DS(ON)}$ of N-CH MOSFET	$I_{SW}=-300mA$		0.35	0.45	Ω
I_{LSW}	SW Leakage	$V_{EN}=0V$, $V_{SW}=0V$ or $5V$, $V_{IN}=5V$		± 0.01	± 1	μA
V_{EN}	EN Threshold	$-40^\circ C \leq T_A \leq 85^\circ C$	0.3	1.0	1.30	V
I_{EN}	EN Leakage Current			± 0.01	± 1	μA

Note 4: 100% production test at +25°C. Specifications over the temperature range are guaranteed by design and characterization.

Typical Performance Characteristics

(Test circuitry is as Figure 2, unless otherwise specified.)

Dynamic Supply Current vs Supply Voltage

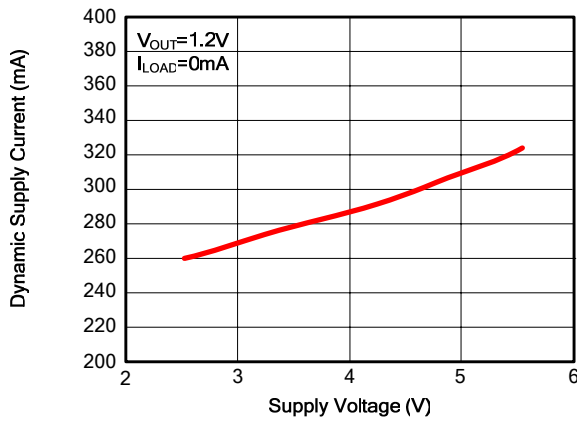

Output Voltage vs Supply Voltage

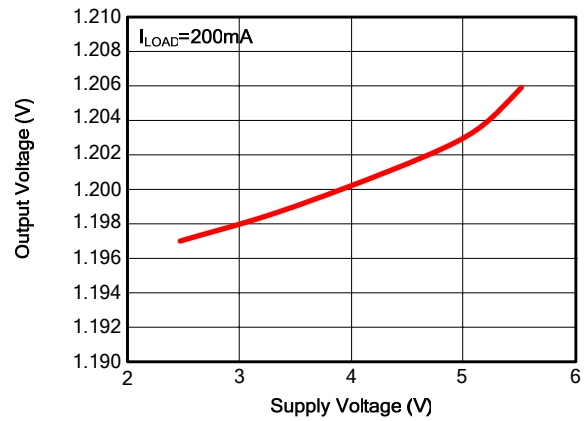

Efficiency vs Output Current

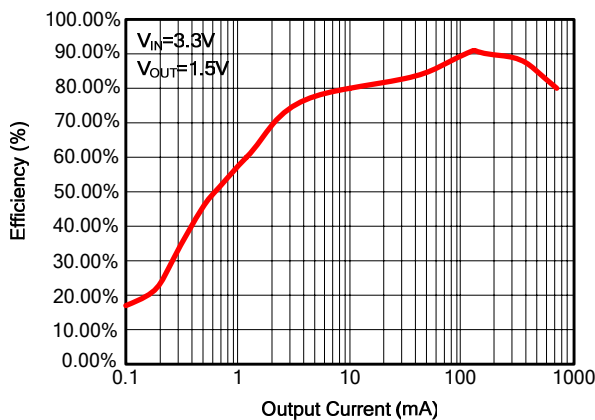

Efficiency vs Output Current

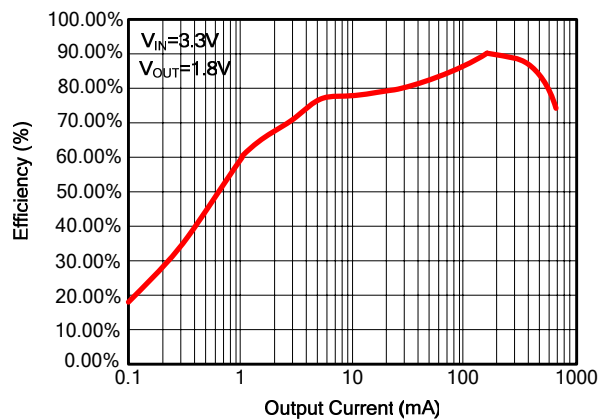

Efficiency vs Output Current

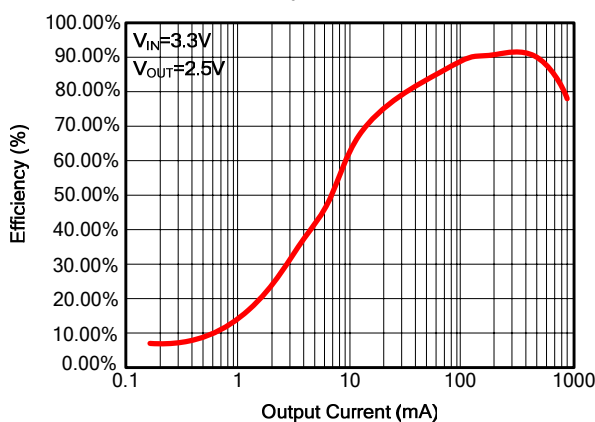

Efficiency vs Output Current

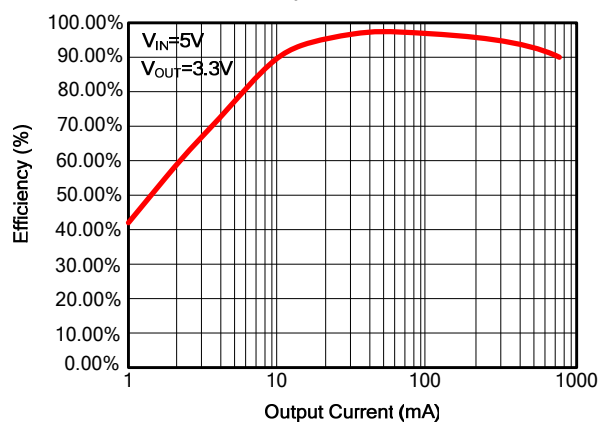

Functional Block Diagram

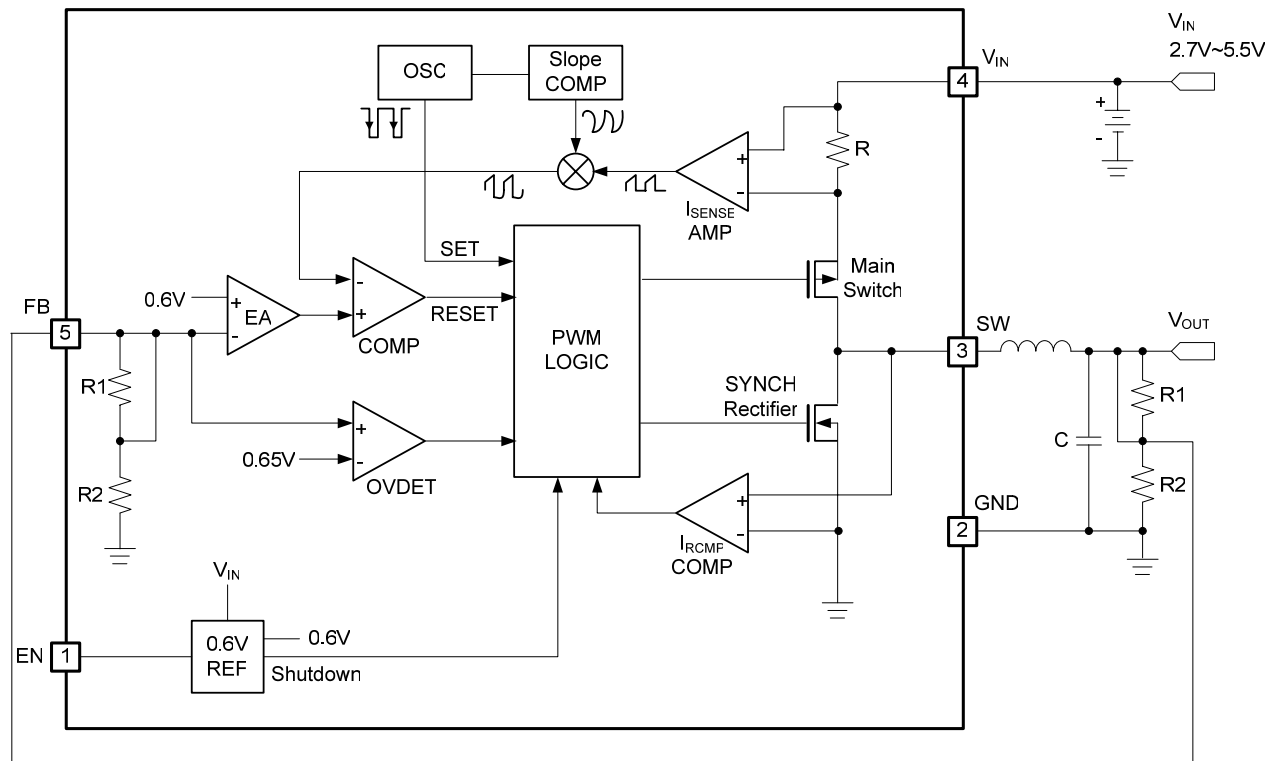

*For Adjustable Output, R1+R2 Is External.

Operation

The EP3001 is a monolithic switching mode Step-Down DC-DC converter. It utilizes internal MOSFETs to achieve high efficiency and can generate very low output voltage by using internal reference at 0.6V. It operates at a fixed switching frequency, and uses the slope compensated current mode architecture.

Current Mode PWM Control

Slope compensated current mode PWM control provides stable switching and cycle-by-cycle current limit for excellent load and line responses and protection of the internal main switch (P-Ch MOSFET) and synchronous rectifier (N-Ch MOSFET). During normal operation, the internal P-Ch MOSFET is turned on for a certain time to ramp the inductor current at each rising edge of the internal oscillator, and switched off when the peak inductor current is above the error voltage. The current comparator, I_{COMP} , limits the peak inductor current. When the main switch is off, the synchronous rectifier will be turned on immediately and stay on until either the inductor current starts to reverse, as indicated by the current reversal comparator, I_{ZERO} , or the beginning of the next clock cycle. The OVDET comparator controls output transient overshoots by turning the main switch off and keeping it off until the fault is no longer present.

Idle Mode Operation

At very light loads, the EP3001 automatically enters Idle Mode. In the Idle Mode, the inductor current may reach zero or reverse on each pulse. The PWM control loop will automatically skip pulses to maintain output regulation. The bottom MOSFET is turned off by the current reversal comparator, I_{ZERO} , and the switch voltage will ring. This is discontinuous mode operation, and is normal behavior for the switching regulator.

Dropout Operation

When the input voltage decreases toward the value of the output voltage, the EP3001 allows the main switch to remain on for more than one switching cycle and increases the duty cycle (*Note 5*) until it reaches 100%. The output voltage then is the input voltage minus the voltage drop across the main switch and the inductor. At low input supply voltage, the $R_{DS(ON)}$ of the P-Ch MOSFET increases, and the efficiency of the converter decreases. Caution must be exercised to ensure the heat dissipated not to exceed the maximum junction temperature of the IC.

Note 5: The duty cycle D of a step-down converter is defined as:

$$D = T_{ON} \times f_{OSC} \times 100\% \approx \frac{V_{OUT}}{V_{IN}} \times 100\%$$

where T_{ON} is the main switch on time, and f_{OSC} is the oscillator frequency (1.5MHz).

Maximum Load Current

The EP3001 will operate with input supply voltage as low as 2.5V, however, the maximum load current decreases at lower input due to large IR drop on the main switch and synchronous rectifier. The slope compensation signal reduces the peak inductor current as a function of the duty cycle to prevent sub-harmonic oscillations at duty cycles greater than 50%. Conversely the current limit increases as the duty cycle decreases.

Short-Circuit Protection

A current limit (1A) circuit is equipped in the EP3001, to protect the EP3001 when the output pin is shorted to GND pin. This current limit will suppress the output current so that the inductor current has enough time to decay.

Applications Information

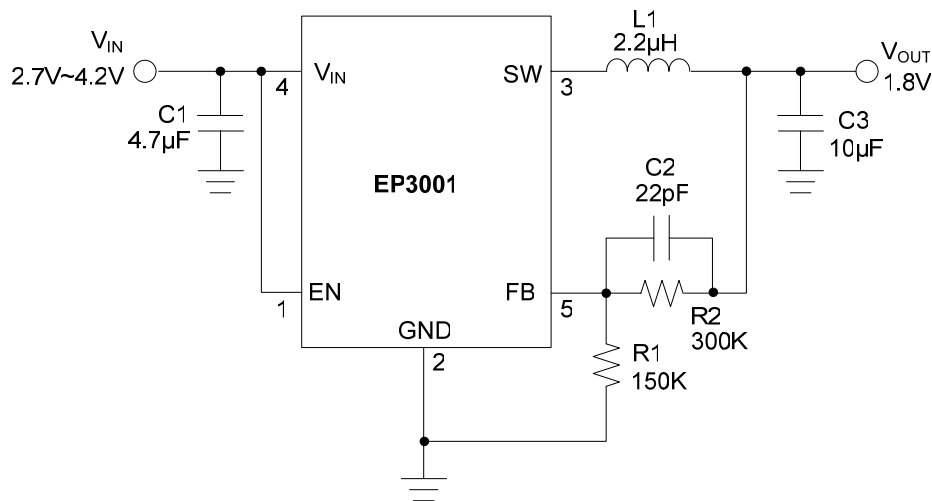

Figure 2-below shows the Basic Application Circuit with EP3001 adjustable versions.

Setting the Output Voltage

Figure 2 above shows the basic application circuit with EP3001 adjustable output version. The external resistor sets the output voltage according to the following equation:

$$V_{OUT} = 0.6V \left(1 + \frac{R2}{R1} \right)$$

- R2 = 300KΩ for all outputs;
- R1 = 300KΩ for V_{OUT} = 1.2V;
- R1 = 200KΩ for V_{OUT} = 1.5V;
- R1 = 150KΩ for V_{OUT} = 1.8V;
- R1 = 95.3KΩ for V_{OUT} = 2.5V;
- R1 = 67KΩ for V_{OUT} = 3.3V

Input Capacitor Selection

The input capacitor reduces the surge current drawn from the input and switching noise from the device. The input capacitor impedance at the switching frequency shall be less than input source impedance to prevent high frequency switching current passing to the input. A low ESR input capacitor sized for maximum RMS current must be used. Ceramic capacitors with X5R or X7R dielectrics are highly recommended because of their low ESR and small temperature coefficients. A 4.7µF ceramic capacitor for most applications is sufficient.

Output Capacitor Selection

The output capacitor is required to keep the output voltage ripple small and to ensure regulation loop stability. The output capacitor must have low impedance at the switching frequency. Ceramic capacitors with X5R or X7R dielectrics are recommended due to their low ESR and high ripple current. The output ripple V_{OUT} is determined by:

$$\Delta V_{OUT} \leq \frac{V_{OUT} \times (V_{IN} - V_{OUT})}{V_{IN} \times f_{OSC} \times L} \times \left(ESR + \frac{1}{8 \times f_{OSC} \times C3} \right)$$

Inductor Selection

For most designs, the EP3001 operates with inductors of 1 μ H to 4.7 μ H. Low inductance values are physically smaller but require faster switching, which results in some efficiency loss. The inductor value can be derived from the following equation:

$$L = \frac{V_{OUT} \times (V_{IN} - V_{OUT})}{V_{IN} \times \Delta I_L \times f_{OSC}}$$

Where ΔI_L inductor Ripple Current. Large value inductors lower ripple current and small value inductors result in high ripple currents. Choose inductor ripple current approximately 35% of the maximum load current 600mA or 210mA.

For output voltages above 2.0V, when light-load efficiency is important, the minimum recommended inductor is 2.2 μ H. For optimum voltage-positioning load transients, choose an inductor with DC series resistance in the 50m Ω to 150m Ω range. For higher efficiency at heavy loads (above 200mA), or minimal load regulation (but some transient overshoot), the resistance should be kept below 100m Ω . The DC current rating of the inductor should be at least equal to the maximum load current plus half the ripple current to prevent core saturation (600mA+105mA). Table 1 lists some typical surface mount inductors that meet target applications for the EP3001.

Part #	L (μ H)	Max DCR (m Ω)	Rated D.C. Current (A)	Size W \times L \times H (mm)
Sumida CR43	1.4	56.2	2.52	4.5 \times 4.0 \times 3.5
	2.2	71.2	1.75	
	3.3	86.2	1.44	
	4.7	108.7	1.15	
Sumida CDRH4D18	1.5	-	-	4.7 \times 4.7 \times 2.0
	2.2	75	1.32	
	3.3	110	1.04	
	4.7	162	0.84	
Toko D312C	1.5	120	1.29	3.6 \times 3.6 \times 1.2
	2.2	140	1.14	
	3.3	180	0.98	
	4.7	240	0.79	

Package Description

5pin TSOT-23 Package Outline Dimensions

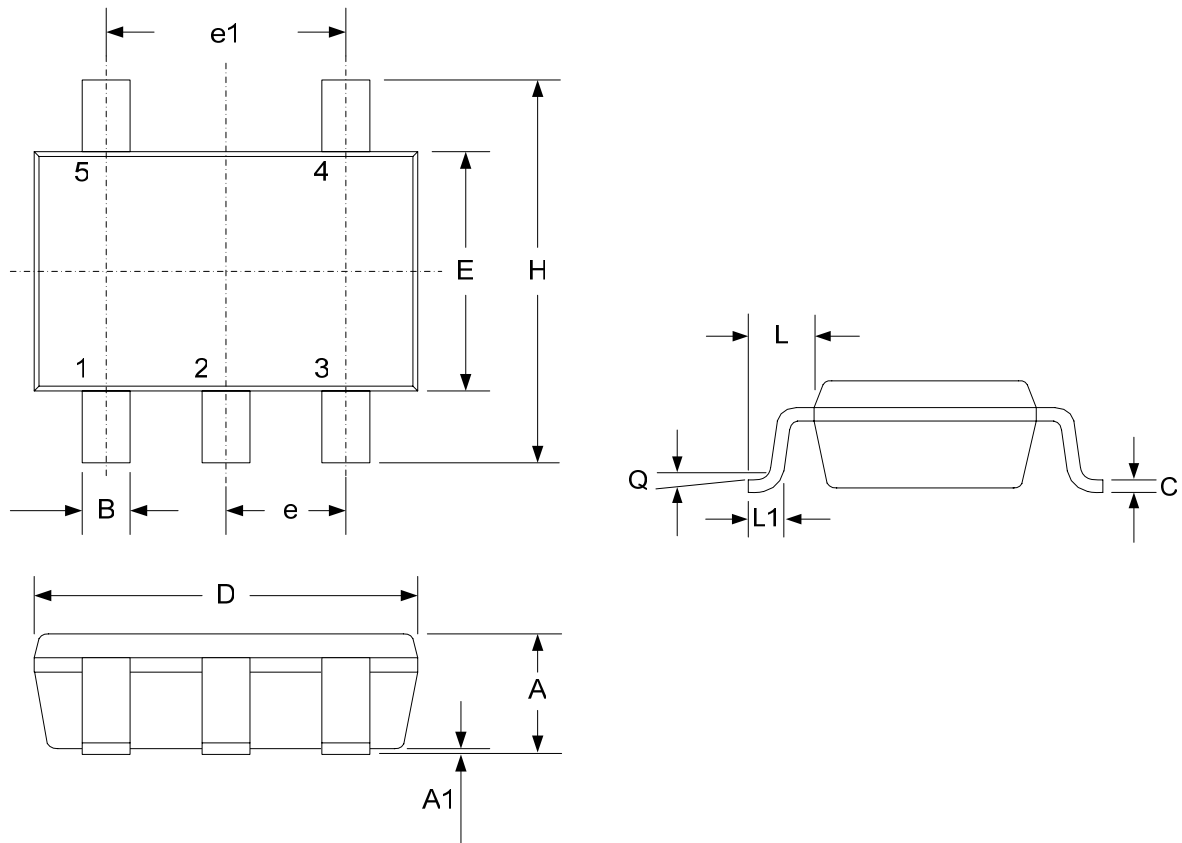

DIM	MILLIMETERS			INCHES		
	MIN.	NOM.	MAX.	MIN.	NOM.	MAX.
A	0.90	-	1.10	0.035	-	0.043
A1	0.01	-	0.13	0.0004	-	0.005
B	0.30	-	0.50	0.012	-	0.020
C	0.09	-	0.20	0.004	-	0.008
D	2.80	-	3.00	0.110	-	0.118
H	2.50	-	3.10	0.098	-	0.122
E	1.50	-	1.70	0.059	-	0.067
e	0.95 REF.			0.037 REF.		
e1	1.90 REF.			0.075 REF.		
L1	0.20	-	0.55	0.008	-	0.022
L	0.35	-	0.80	0.014	-	0.031
Q	0°	-	10°	0°	-	10°

* Package outline exclusive of mold flash and metal burr.