

---

**1 MHz Five-channel Power Supply****FEATURES**

- Up to 95% efficiency Step-up and up to 92% efficient Step-down converters
- Combine Step-up and Step-down for up to 87% efficiency buck-boost operations
- Minimum 0.7V input voltage
- 2 $\mu$ A shutdown mode
- Internal soft start control
- Overload protection
- Compact QFN-32 5 x 5 mm package

**APPLICATIONS**

- Digital still camera
- Digital video camera
- PDA
- MP3
- PMP
- Portable DVD Player
- Car navigation

**DESCRIPTION**

The EP1551 is a small, high efficiency, five-channel, power-supply for digital still and video cameras. It consists of:

- Step-up DC-DC converter with on-chip power MOSFETs for 3.3V main system supply with up to 95% efficiency. It accepts inputs from 0.7V to 5.5V and regulates a resistor-adjustable output from 2.7V to 5.5V.
- Step-down main DC-DC converter with on-chip power MOSFETs for 1.5V DSP core supply with up to 92% efficiency. It can operate from the Step-up main system supply providing buck-boost capability with up to 90% compound efficiency, or it can run directly from battery if buck-boost operation is not needed.
- PWM controller with external FET for Step-up DC-DC converter for 5V motor actuator
- PWM controller with external FET for 15V LCD supply
- PWM controller with external FET and transformer for -7.5V and +15V CCD Bias

All DC-DC channels operate at one fixed frequency settable from 100KHz to 1MHz to optimize size, cost and efficiency. Other features include soft-start, power-OK outputs, and overload protection. The EP1551 is available in space saving QFN-32 5 x 5 mm packages. An evaluation kit is also available to expedite design.

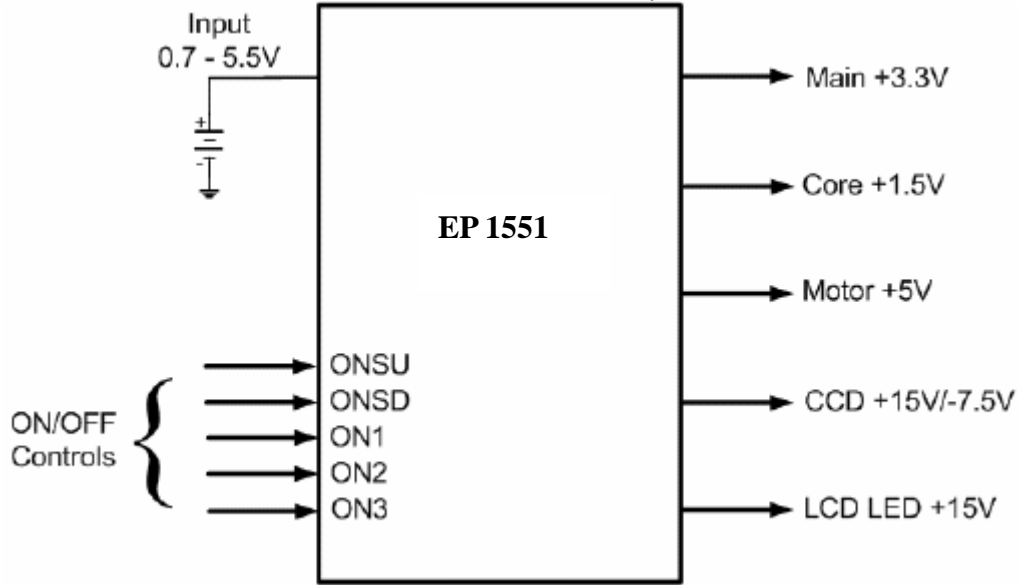
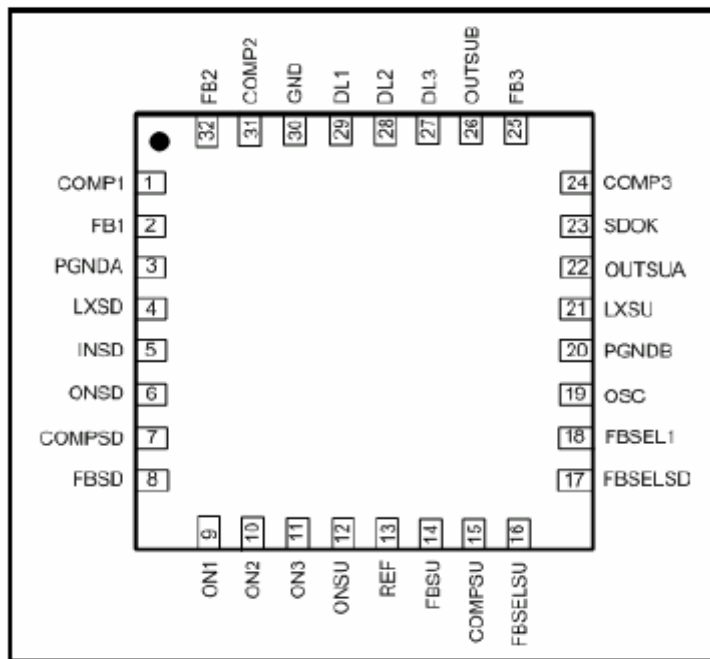

Figure 1. Basic Application Circuit with EP1551 example

**Package/ Order Information**



5mm x 5mm 32-QFN

Eorex	Power Management	Multi-channel Power-supply	Series Number
<b>E</b>	<b>P</b>	<b>15</b>	<b>51</b>

**Absolute Maximum Rating** <sup>(Note 1)</sup>

OUTBU\_, INSD, SDOK, ON\_, FB\_, FBSEL\_ to GND..... -0.3V to +6V  
 PGND to GND ..... -0.3V to +0.3V  
 DL\_ to PGND.....-0.3V to OUTSU+0.3V  
 LXSU Current <sup>(Note 2)</sup> .....3.6A  
 LXSD Current <sup>(Note 2)</sup> .....2.25A  
 REF, OSC, COMP\_ to GND.....-0.3V to OUTSU+0.3V  
 Continuous Power Dissipation (TA=70°C, derate 22mW/°C above +70°C).....1700mW  
 Operating Temperature Range..... -40°C to +85°C  
 Junction Temperature .....+150°C  
 Storage Temperature Range..... -65°C to +150°C  
 Lead Temperature (Soldering, 10s) .....+150°C

**Note 1:** Absolute Maximum Ratings are those values beyond which the life of a device may be impaired.

**Note 2:** LXSU has internal clamp diodes to OUTSU and PGND, and LXSD has internal clamp diodes to INSD and PGND. Applications that forward bias these diodes should take care not to exceed the devices power dissipation limits.

**Electrical Characteristics**

(VOOTSU = 3.3V, TA = 0°C to +85°C, unless otherwise noted.)

Parameter	Conditions	MIN	TYP	MAX	unit
<b>GENERAL:</b>					
Input Voltage Range		0.7		5.5	V
Minimum Startup Voltage	ILOAD < 1mA, TA = +25°C		1.2	1.4	V
Thermal Shutdown			160		°C
Thermal-Shutdown Hysteresis			20		°C
Shutdown Supply Current into OUTSU	ONSU = ONSD = ON1 = ON2 = ON3 = 0, OUTSU = 3.6V		0.3	5	µA
Step-up DC-DC Supply Current into OUTSU	ONSU = 3.35v, FBSU = 1.5V (does not include switching losses)		320	400	µA
Step-up Plus 1 AUX Supply Current into OUTSU	ONSU = ON_ = 3.35V, FBSU = 1.5V, FB_ = 1.5V (does not include switching losses)		385	600	µA
Step-up Plus Step-down Supply Current into OUTSU	ONSU = ONSD = 3.35V, FBSU = 1.5V, FBSD = 1.5V (does not include switching losses)		1030	1300	µA
Reference Output Voltage	IREF = 20 µA	1.225	1.25	1.275	V
Reference Load Regulation	10µA < IREF < 200µA		4.5	10	mV
Reference Line Regulation	2.7 < OUTSU < 5.5V		1.3	5	mV
OSC Discharge Trip Level	Rising edge	1.225	1.25	1.275	V
OSC Discharge Resistance	OSC = 1.5v, IOSC = 3mA		52	80	Ω
OSC Discharge Pulse Width			230		ns
OSC Frequency	ROSC = 40K., COSC = 100pF		400		KHz

Parameter	Conditions	MIN	TYP	MAX	unit
<b>STEP-UP DC-DC CONVERTER :</b>					
Step-up Startup-to-Normal Operating Threshold	Rising or falling edge	2.3	2.5	2.6	V
Step-up Startup-to-Normal Operating Threshold Hysteresis			80		mV
Step-up Voltage Adjust Range		2.7		5.5	V
FBSU Regulation Voltage		1.225	1.25	1.275	V
OUTSU Regulation Voltage	FBSELSU = GND	3.250	3.350	3.450	V
FBSU to COMPSU Transconductance	FBSU = COMPSU	80	135	185	μS
FBSU Input Leakage Current	FBSU = 1.25V	-100	1	100	nA
Idle-Mode Trip Level		150	200	265	mA
Current-Sense Amplifier Transresistance			0.3		V/A
Step-up Maximum Duty Cycle	FBSU = 1V	80	85	90	%
OUTSU Leakage Current	V <sub>LXSU</sub> = 0V, OUTSU = 5.5V		0.01	20	μA
LXSU Leakage Current	V <sub>LXSU</sub> = OUTSU = 5.5V		0.01	20	μA
Switch On-Resistance	N-channel		95	105	mΩ
	P-channel		150	250	
N-Channel Current Limit			2		A
P-Channel Turn-Off Current			20		mA
Startup Current Limit	OUTSU = 1.8V	1.2	670		mA
Startup tOFF	OUTSU = 1.8V		515		ns
Startup Frequency	OUTSU = 1.8V	0.3	244		KHz
<b>STEP-DOWN DC-DC CONVERTER :</b>					
FBSD Regulation Voltage		1.225	1.25	1.275	V
OUTSD Regulation Voltage	FBSELSD=GND	1.470	1.500	1.530	V
FBSD TO COMPSD Transconductance	FBSD=COMPSD	80	135	185	uS
FBSD Input Leakage Current	FBSD=1.25V	-100	1	100	nA
Idle-Mode Trip level		110	160	190	mA
Current-Sense Amplifier Transresistance			0.6		V/A
LXSD Leakage Current	V <sub>LXSD</sub> = 5.5V OUTSU = 5.5V		0.01	20	μA
	V <sub>LXSD</sub> = 0V OUTSU = 5.5V		0.01	20	
Switch On-Resistance	N-channel		90	150	Ω
	P-channel		150	250	
P-channel Current Limit			0.79		A
N-channel Turn-off Current			20		mA
Soft-start Interval			4096		OSC cycle
SDOK Output Low Voltage	FBSD=0.4v, 0.1mA into SDOK pin		0.002	0.1	V
SDOK Operating Voltage		1		5.5	V

Parameter	Conditions	MIN	TYP	MAX	unit
<b>AUXILIARY DC-DC CONTROLLERS (AUX 1, 2, AND 3) :</b>					
Maximum Duty Cycle	FB_ = 1V	80	85	90	%
FB_ Regulation Voltage		1.225	1.25	1.275	V
FB_ to COMP_ Transconductance	FB_ = COMP_	80	135	185	μS
FB_ Input Leakage Current	FBSU =1.25V	-100	2	100	nA
AUX1 Output Regulation Voltage	FBSEL1 = GND, FB1connected directly AUX1 output	4.85	5	5.15	V
DL_ Driver Resistance	Output high		3	10	Ω
	Output low		2	5	
DL_ Driver Current	Sourcing or sinking		0.5		A
Soft-Start Interval			4096		OSC cycle
<b>LOGIC INPUTS (ON_, FBSEL):</b>					
Input Low Level	1.1V < OUTSU < 1.8V (ONSU only)			0.2	V
	1.8V < OUTSU < 5.5V			0.4	
Input High Level	1.1V < OUTSU < 1.8V (ONSU only)	VOUT SU -0.2			V
	1.8V < OUTSU < 5.5V	1.6			
FBSEL_ Input Leakage Current	FBSEL = 3.6V, OUTSU = 3.6V	-100	0	100	nA
	FBSEL = GND, OUTSU = 3.6V	-100	0	100	
ONSU Impedance to GND	ONSU=3.35V		303		KΩ
ONSD Impedance to GND	ONSD=3.35V		275		KΩ
ON_ Impedance to GND	ON_ =3.35V		308		KΩ

Typical Operating Characteristics

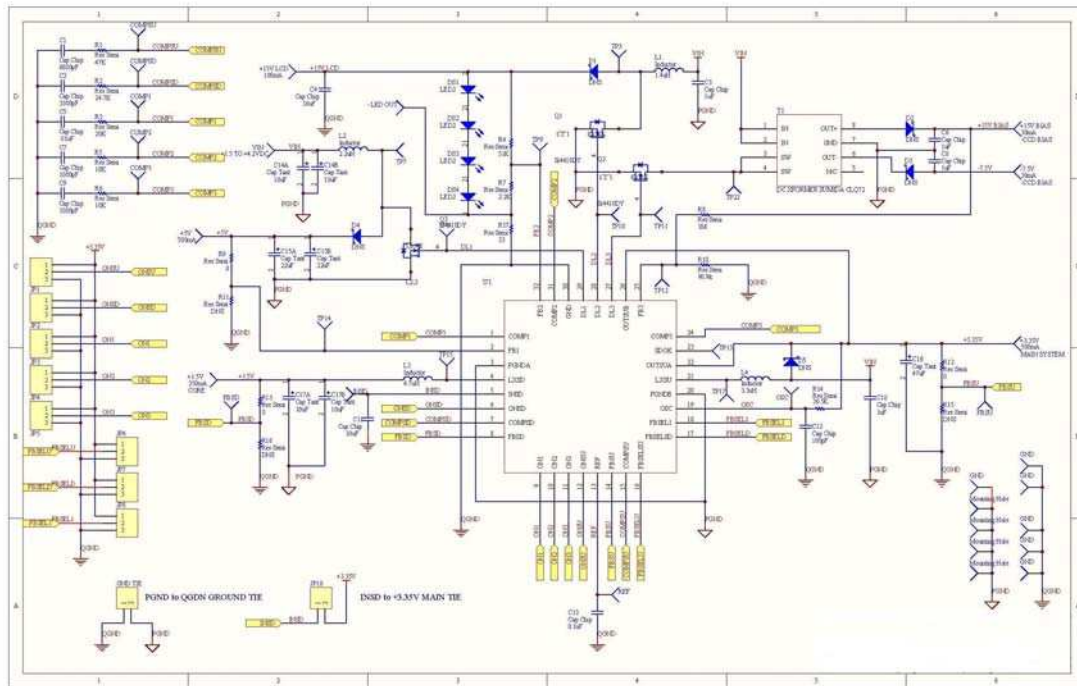

(Circuit of Figure 2, TA = 25°C, unless otherwise noted.)

Figure 2, Typical Application Circuit (EP1551 Evaluation Board schematic)

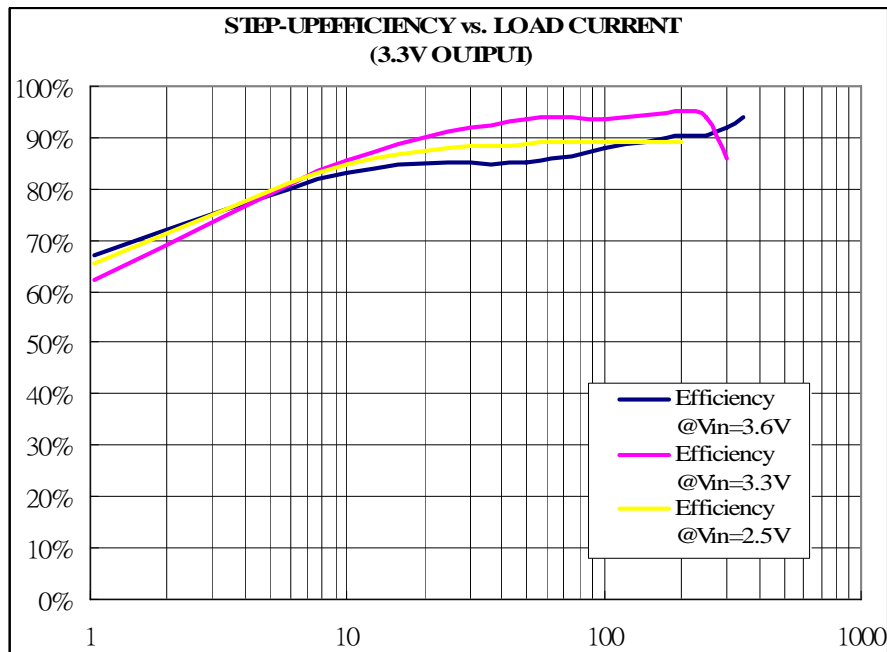

Figure 3. EP1551 Step-up Efficiency vs Load Current

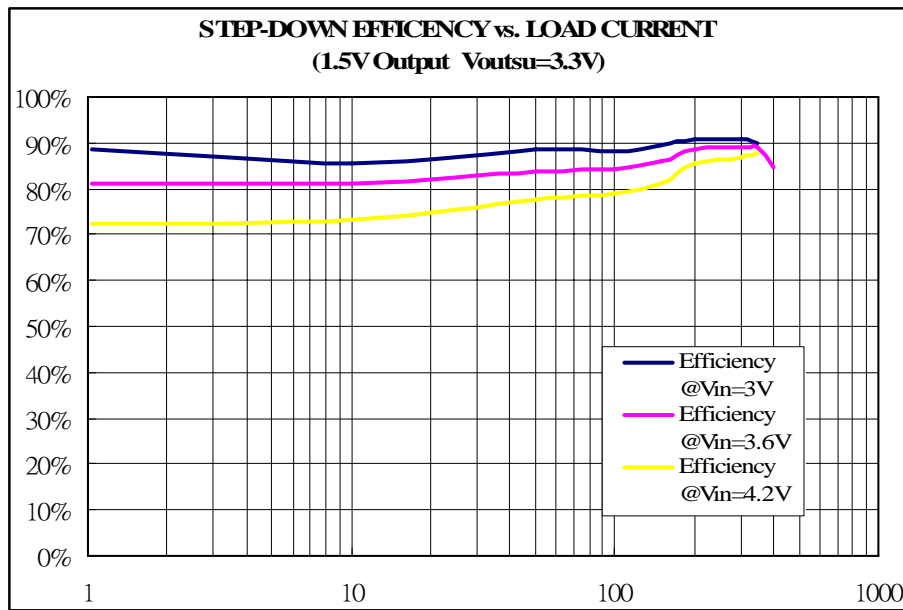

Figure 4. EP1551 Step-down Efficiency vs. Load Current

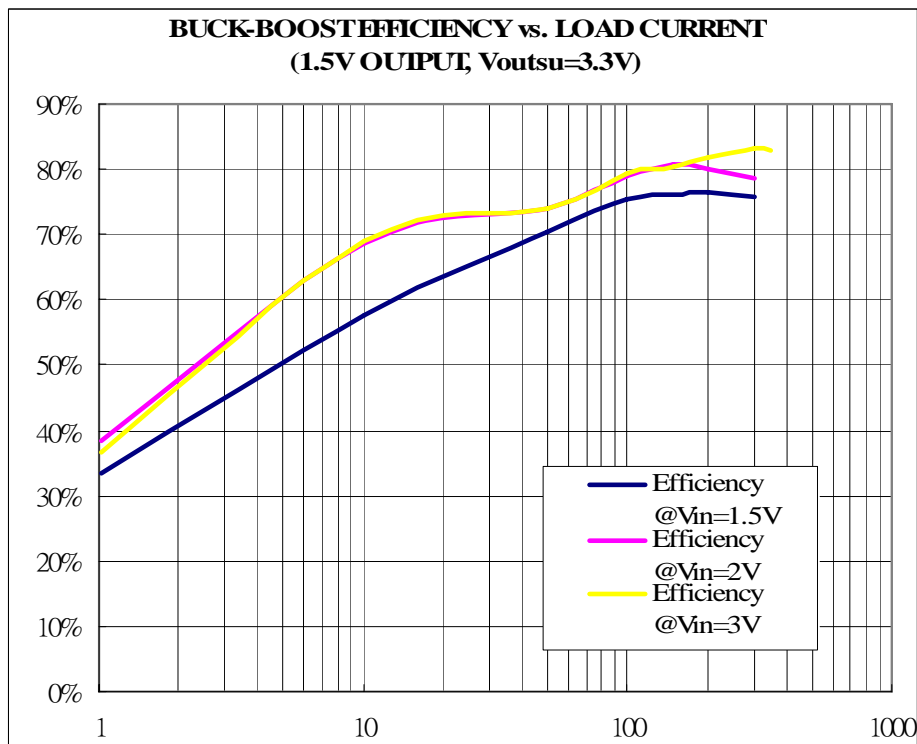

Figure 5. EP1551 Buck-Boost Efficiency vs. Load Current

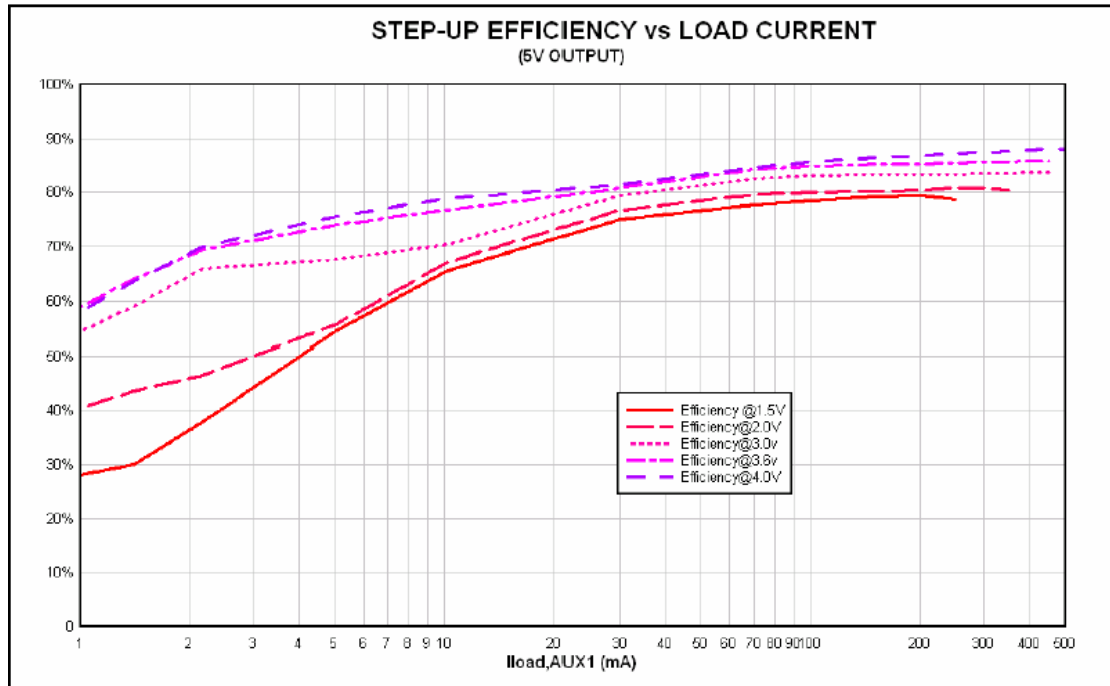

Figure 6. EP1551 Auxiliary PWM Step-up Efficiency vs. Load Current

Functional Block Diagram

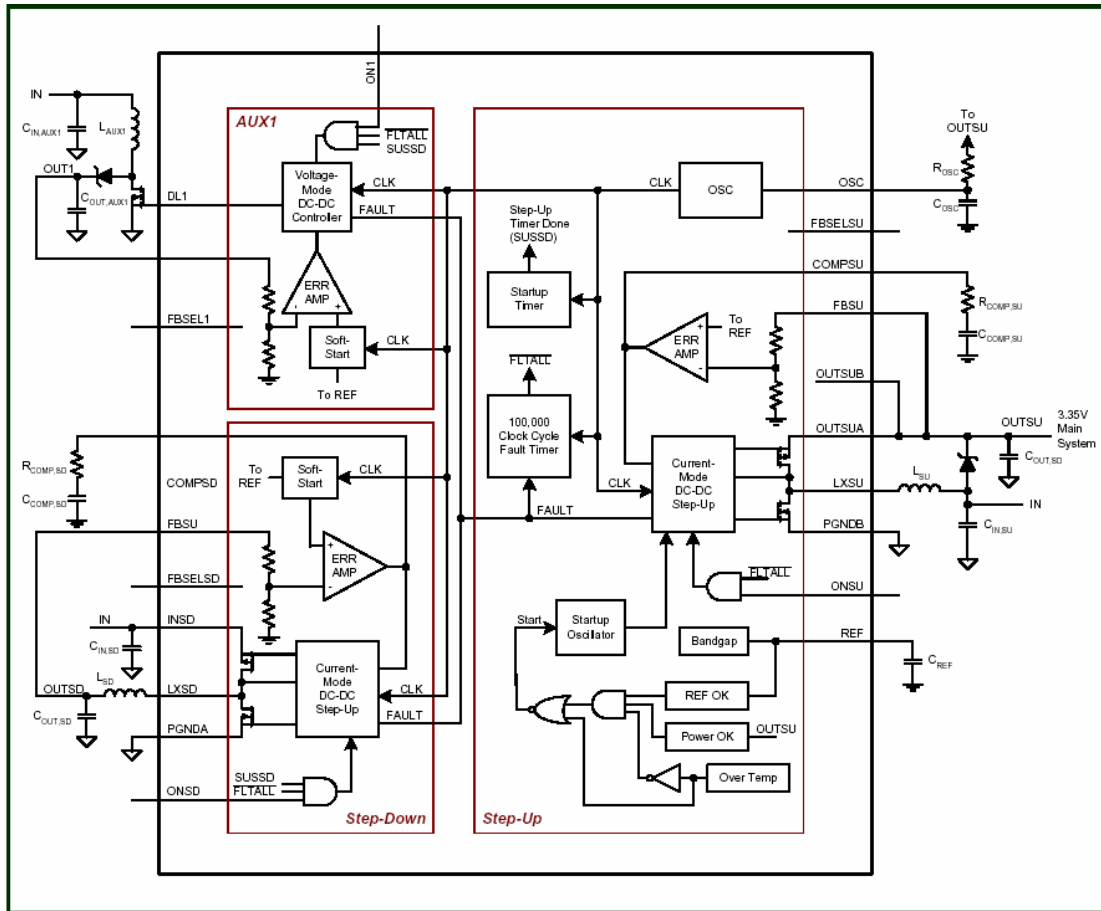

Figure 7. Block Diagram for EP1551

Pin Description

PIN	NAME	FUNCTION
1	COMP1	Auxiliary Controller 1 Compensation Node. Connect a series RC from COMP1 to GND to compensate the control loop. COMP1 is actively driven to GND in shutdown and thermal limit.
2	FB1	Auxiliary Controller 1 Feedback Input. For 5V output, short FBSEL1 to GND and connect FB1 to the output voltage. For other output voltages, connect FBSEL1 to OUTSU and connect a resistive voltage-divider from the Step-up converter output to FB1 to GND. The FB1 feedback threshold is then 1.25V. This pin is high impedance in shutdown.
3	PGNDA	Power Ground. Connect PGNDA and PGNDB together and to GND with short trace as close to the IC as possible.
4	LXSD	Step-down Converter Power-Switching Node. Connect LXSD to the Step-down converter inductor. LXSD is the drain of the P-channel switch and N-channel synchronous rectifier. LXSD is high impedance in shutdown.
5	INSD	Step-down Converter Input. INSD can connect to OUTSU, effectively making OUTSD a buck-boost output from the battery. Bypass to GND with a 1µF ceramic capacitor if

		connected to OUTSU. INSD may also be connected to the battery, but should not exceed OUTSU by more than a Schottky diode forward voltage. Bypass INSD with a 10 $\mu$ F ceramic capacitor when connecting to the battery input. A 10k $\Omega$ internal resistance connects OUTSU and INSD.
6	ONSD	Step-down Converter On/Off Control Input. Drive ONSD high to turn on the Step-down converter. This pin has an internal 330k. pull down resistor. ONSD does not start until OUTSU is in regulation.
7	COMPSD	Step-down Converter Compensation Node. Connect a series RC from COMPSD to GND to compensate the control loop. COMPSD is pulled to GND in normal shutdown and during thermal shutdown.
8	FBSD	Step-down Converter Feedback Input. For a 1.5V output, short FBSELSD to GND and connect FBSD to OUTSD. For other voltages, short FBSELSD to OUTSU and connect a resistive voltage-divider from OUTSD to FBSD to GND. The FBSD feedback threshold is 1.25V. This pin is high impedance in shutdown.
9	ON1	Auxiliary Controller 1 On/Off Control Input. Drive ON1 high to turn on. This pin has an internal 330k. pull down resistor. ON1 cannot start until OUTSU is in regulation.
10	ON2	Auxiliary Controller 2 On/Off Control Input. Drive ON2 high to turn on. This pin has an internal 330k. pull down resistor. ON2 cannot start until OUTSU is in regulation.
11	ON3	Auxiliary Controller 3 On/Off Control Input. Drive ON3 high to turn on. This pin has an internal 330k $\Omega$ pull down resistor. ON3 cannot start until OUTSU is in regulation.
12	ONSU	Step-up Converter On/Off Control. Drive ONSU high to turn on the Step-up converter. All other control pins are locked out until 2ms after the Step-up output has reached its final value. This pin has an internal 330k. resistance to GND.
13	REF	Reference Output. Bypass REF to GND with a 0.1 $\mu$ F or greater capacitor. The maximum allowed load on REF is 200 $\mu$ A. REF is actively pulled to GND when all converters are shut down.
14	FBSU	Step-up Converter Feedback Input. To regulate OUTSU to 3.35V, connect FBSELSU to GND. FBSU may be connected to OUTSU or GND. For other output voltages, connect FBSELSU to OUTSU and connect a resistive voltage-divider from OUTSU to FBSU to GND. The FBSU feedback threshold is 1.25V. This pin is high impedance in shutdown.
15	COMPUSU	Step-up Converter Compensation Node. Connect a series RC from COMPUSU to GND to compensate the control loop. COMPUSU is pulled to GND in normal shutdown and during thermal shutdown.
16	FBSELSU	Step-up Feedback Select Pin. With FBSELSU = GND, OUTSU regulates to 3.35V. With FBSELSU = OUTSU, FBSU regulates to a 1.25V threshold for use with external feedback resistors. This pin is high impedance in shutdown.
17	FBSELSD	Step-down Feedback Select Pin. With FBSELSD = GND, FBSD regulates to 1.5V. With FBSELSD = OUTSU, FBSD regulates to 1.25V for use with external feedback resistors. This pin is high impedance in shutdown.
18	FBSEL1	Auxiliary Controller 1 Feedback Select Pin. With FBSEL1 = GND and FB1 regulates to 5V. With FBSEL1 = OUTSU, FB1 regulates to 1.25V for use with external feedback resistors. This pin is high impedance in shutdown.
19	OSC	Oscillator Control. Connect a timing capacitor from OSC to GND and a timing resistor from OSC to OUTSU to set the oscillator frequency between 100kHz and 1MHz. This

		pin is high impedance in shutdown.
20	PGNDB	Power Ground. Connect PGNDA and PGNDB together and to GND with short trace as close to the IC as possible.
21	LXSU	Step-up Converter Power-Switching Node. Connect LXSU to the Step-up converter inductor. LXSU is high impedance in shutdown.
22	OUTSUA	Step-up Converter Output. OUTSUA is the power output of the Step-up converter. Connect OUTSUA to OUTSUB at the IC.
23	SDOK	This open-drain output goes high impedance when the Step-down has successfully completed soft-start.
24	COMP3	Auxiliary Controller 3 Compensation Node. Connect a series resistor-capacitor from COMP3 to GND to compensate the control loop. COMP3 is actively driven to GND in shutdown and thermal limit.
25	FB3	Auxiliary Controller 3 Feedback Input. Connect a resistive voltage-divider from the output voltage to FB3 to GND. The FB3 feedback threshold is 1.25V. This pin is high impedance in shutdown.
26	OUTSUB	Step-up Converter Output. OUTSUB powers the EP1551 and is the sense input when FBSELSU is GND and the output is 3.3V. Connect OUTSUA to OUTSUB.
27	DL3	Auxiliary Controller 3 Gate-Drive Output. Connect the gate of an N-channel MOSFET to DL3. DL3 swings from GND to OUTSU and supplies up to 500mA. DL3 is driven to GND in shutdown and thermal limit.
28	DL2	Auxiliary Controller 2 Gate-Drive Output. Connect the gate of an N-channel MOSFET to DL2. DL2 swings from GND to OUTSU and supplies up to 500mA. DL2 is driven to GND in shutdown and thermal limit.
29	DL1	Auxiliary Controller 1 Gate-Drive Output. Connect the gate of an N-channel MOSFET to DL1. DL1 swings from GND to OUTSU and supplies up to 500mA. DL1 is driven to GND in shutdown and thermal limit.
30	GND	Quiet Ground. Connect GND to PGND as close to the IC as possible.
31	COMP2	Auxiliary Controller 2 Compensation Node. Connect a series resistor-capacitor from COMP2 to GND to compensate the control loop. COMP2 is actively driven to GND in shutdown and thermal limit.
32	FB2	Auxiliary Controller 2 Feedback Input. Connect a resistive voltage-divider from the output voltage to FB2 to GND to set the output voltage. The FB2 feedback threshold is 1.25V. This pin is high impedance in shutdown.
Exposed Pad	EP	Exposed Underside Metal Pad. This pad must be soldered to the PC board to achieve package thermal and mechanical ratings. The exposed pad is electrically connected to GND.

**OPERATION**

- EP1551 includes five channels, a current-mode Step-up DC-DC converter, a current-mode Step-down DC-DC converter, and three auxiliary voltage-mode DC-DC controllers. All these channels employ fixed frequency PWM operator.
- Step-up is typically used to supply 3.3V for main system power. Reference voltage and clocks are also generated in this channel.
- SUSSD (Step-up timer done) keeps low for 1,024 clock cycles after ONSU goes high, which means in typical application case (clock frequency equals 400kHz), the other four channels will be enabled after 2.56ms.
- Step-down DC-DC converter can be powered from the battery, or from the output of Step-up DC-DC converter.
- Three auxiliary controllers are almost same, but only AUX1 has optional internal divider for feedback.
- If any channel remains faulted (no reset signal generated by the comparator) for 100,000 clock cycles, then `_FLTALL` goes low, all outputs latch off until the Step-up DC-DC converter is reinitialized by ONSU, or by cycling of input power. The fault-detection for any channel is disabled during its initial turn-on soft-start sequence.

**Step-up DC-DC Converter**

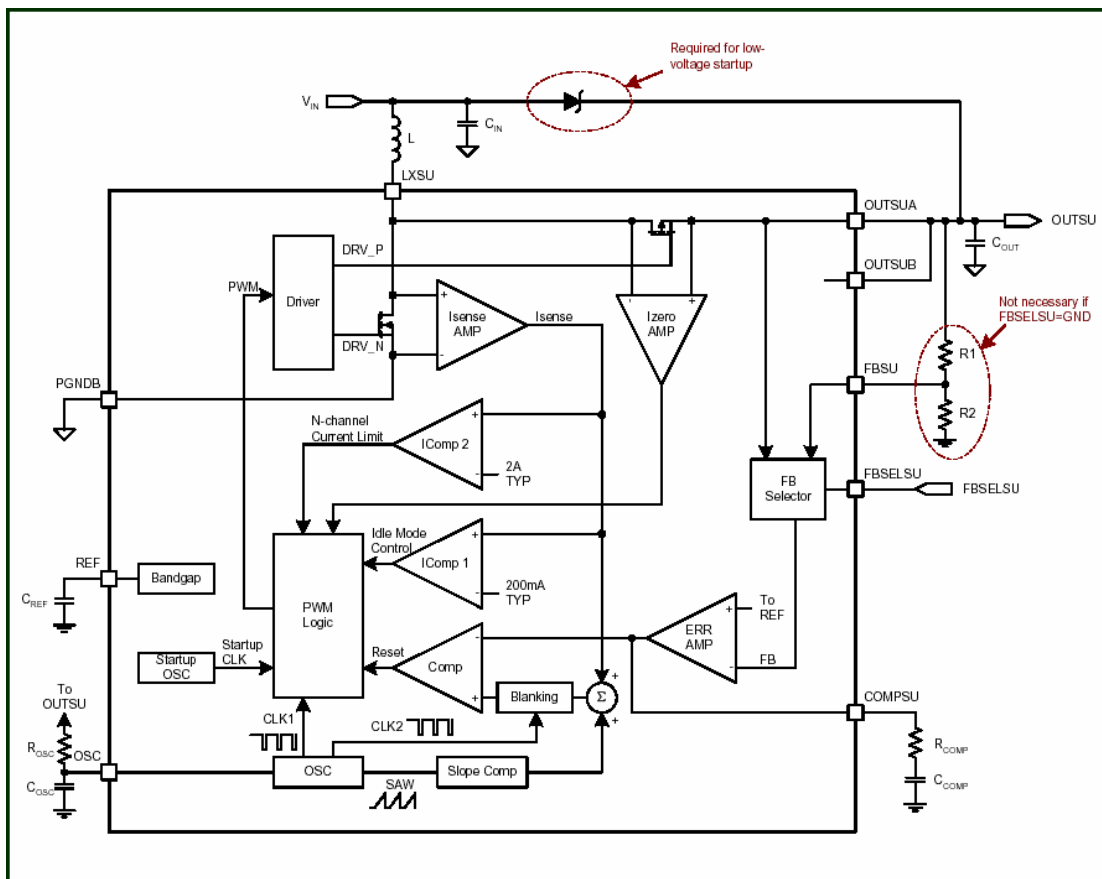

Figure 8. Block Diagram for Current-Mode Step-up DC-DC Converter

- During startup, P-channel switch transistor is always off, N-channel switch transistor is controlled by startup oscillator's output. N-channel switch transistor has fixed off time, its on time is determined by startup current limit, inductor value, and input voltage.
- When OUTSU reaches 2.5V, startup is complete, and the main circuits begin to work.
- The oscillator's frequency is determined by the RC network at OSC pin and the output voltage of Step-up DCDC converter, so the frequency changes as OUTSU ramps upward following startup.
- Current sense amplifier (Isense AMP) senses inductor current when N-channel switch transistor is on. When inductor's peak current reaches 2A, N-channel switch transistor will be turned off.
- Reverse current sense amplifier (Izero AMP) senses inductor current when P-channel switch transistor is on. When inductor current falls to zero, P-channel switch transistor will be turned off.
- If Step-up DC-DC converter has moderate or heavy load, inductor current is controlled by the output of error amplifier (ERR AMP). With light load, Step-up DC-DC converter operates in idle-mode to improve the efficiency. In idle-mode, peak current of every pulse is fixed at 200mA, and some pulses are skipped.

### Step-down DC-DC Converter

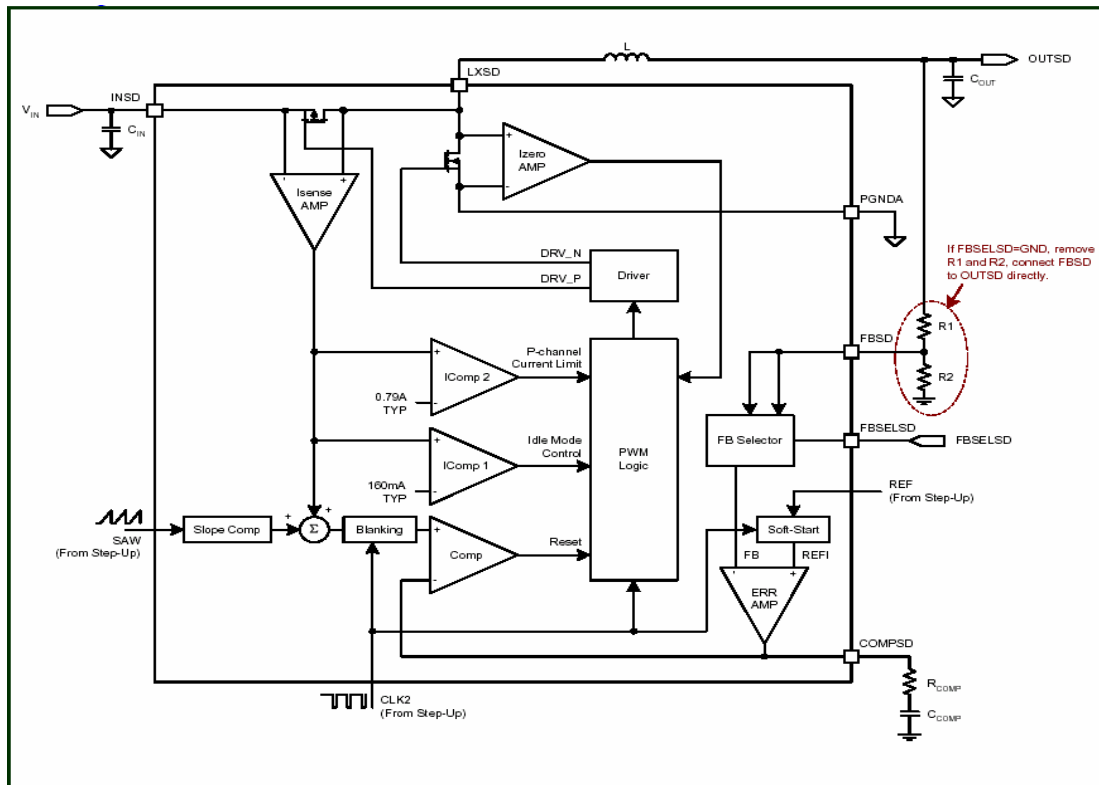

Figure 9. Block Diagram for Current-Mode Step-down DC-DC Converter

- The structure of Step-down DC-DC converter is similar to that of Step-up DC-DC converter. Soft-start circuit is used to ramp the internal reference up from 0V to 1.25V.

Auxiliary DC-DC Controllers

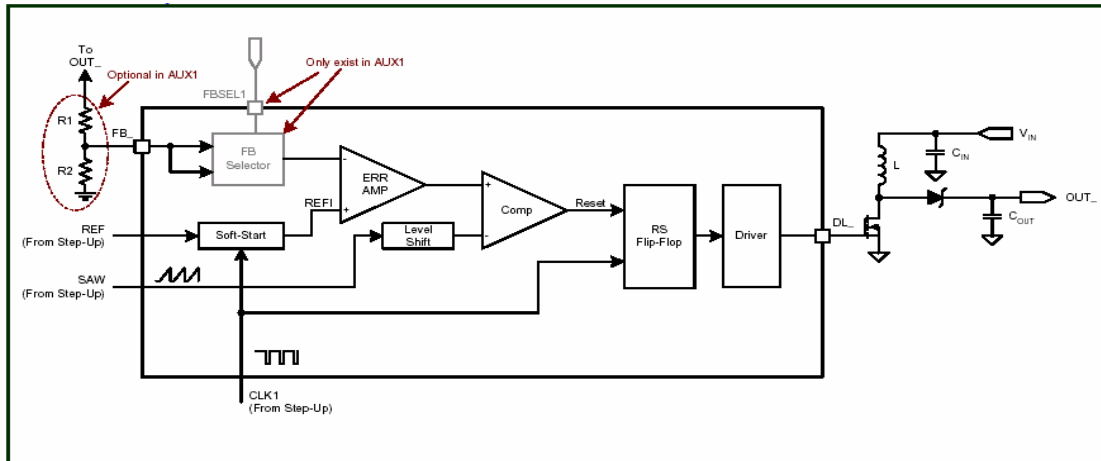

Figure 10. Block Diagram for Voltage-Mode Auxiliary DC-DC Controllers

- The three auxiliary voltage-mode DC-DC controllers are almost same. The only difference is just AUX1 has optional internal divider. AUX2 and AUX3 must use external divider for feedback. Soft-start circuit is used to ramp internal reference up from 0V to 1.25V. Output pulse width is modulated by the output of error amplifier (ERR AMP).

Package Description

QFN-32 5 x 5 mm

DIMENSIONS :

	A	A1	A3	b	D	E	e	k	L	N	ND	NE
MIN.	0.70	0.00	0.2 ref.	0.20	4.90	4.90	0.5 bsc.	0.25	0.30	32	8	8
NOM.	0.75	0.02		0.25	5.00	5.00		-	0.40			
MAX.	0.80	0.05		0.30	5.10	5.10		-	0.50			

SIDE VIEW :

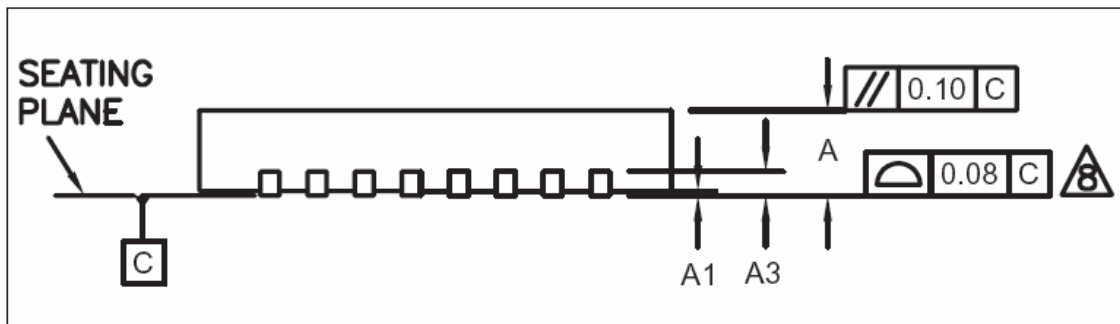

TERMINAL :

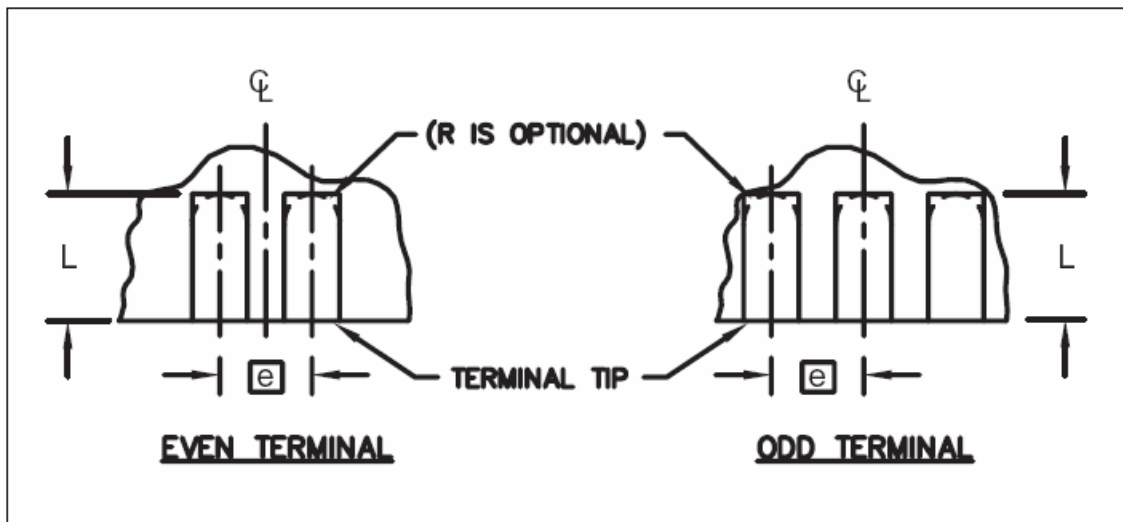

Top View:

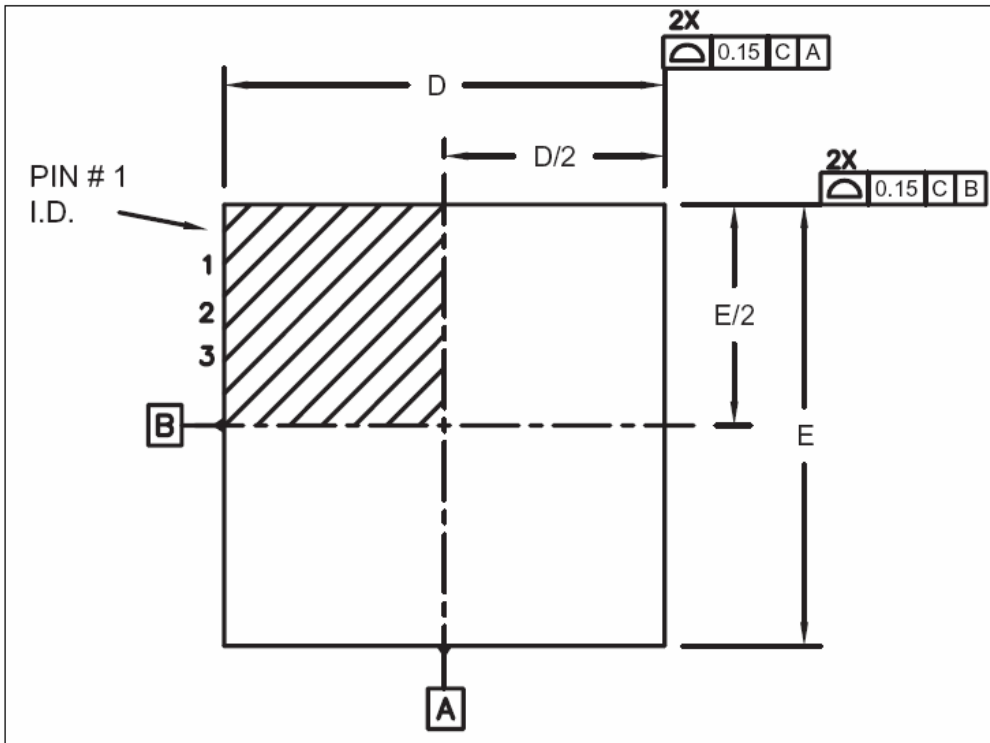

Bottom View:

