

1A Low Dropout Linear Regulator

Features

- Guaranteed Output Voltage Accuracy within 2%
- Fast Transient Response
- Load Regulation: 0.1% Typ.
- Line Regulation: 0.03% Typ.
- Low Dropout Voltage: 1.1V Typ. at $I_{OUT} = 1A$
- On-chip Thermal Limiting: 150°C Typ.
- Adjustable Output: 1.25~10.7V
- Standard 3-pin SOT-223 and TO252 Power Packages

Applications

- PC peripheral
- Low Voltage Logic Supplies
- Post Regulator for Switching Power Supply

Description

The EP1117 is a low dropout three-terminal adjustable or fixed-voltage regulator with 1A output current capability. The EP1117 is available in an adjustable version, with output ranging from 1.25V to 10.7V and fixed output voltages of 1.8V, 2.5V, 3.3V and 5.0V. Dropout voltage is guaranteed at a maximum of 1.3V at 1A. On-chip thermal limiting provides protection against any combination of overload that would create excessive junction temperatures. The EP1117 is available in the industry standard 3-pin the low profile surface mount SOT-223 and TO-252 power packages.

Typical Application

Fixed Mode Regulator

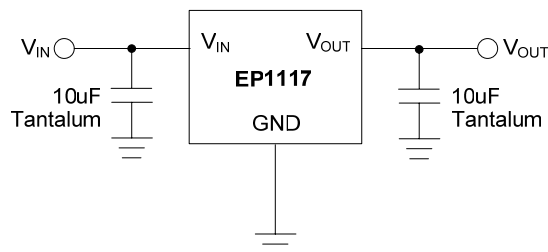

1.25V to 10.7V Adjustable Regulator

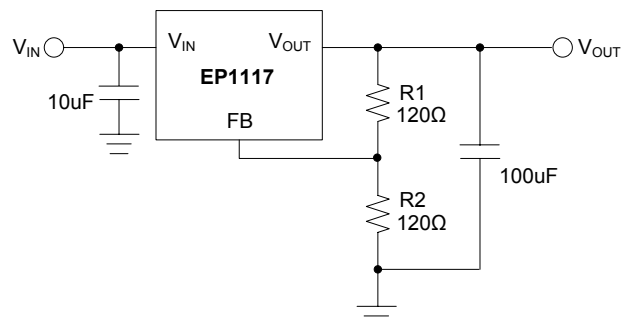

$$V_{OUT} = V_{REF} \times \left(1 + \frac{R2}{R1} \right)$$

$$V_{REF} = 1.25V$$

$$R1 \cong 100\Omega \sim 200\Omega$$

Pin Assignment

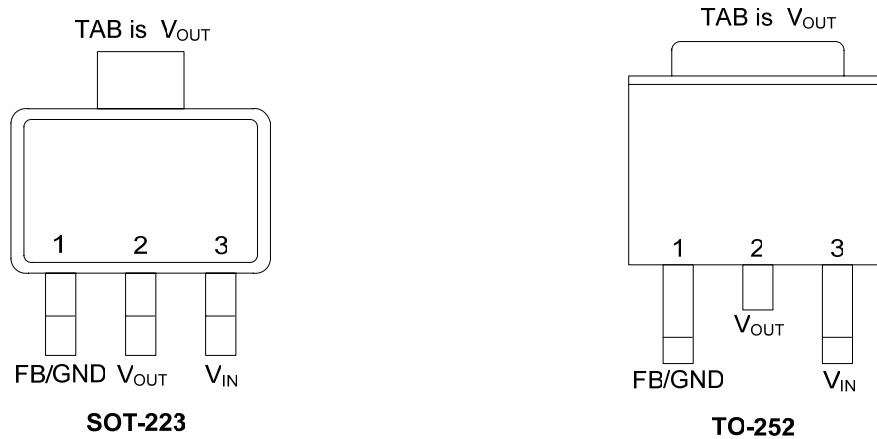

Ordering Information

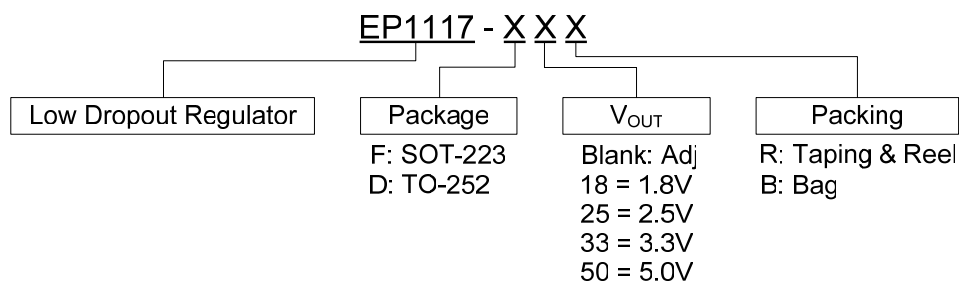

Pin Description

Pin	Name	Function
1	FB/GND	A resistor divider from this pin to the Vout pin and ground sets the output voltage. (Ground only for Fixed-Mode)
2	V_{OUT}	The output of the regulator. A minimum of 10uF capacitor ($0.15\Omega \leq ESR \leq 20\Omega$) must be connected from this pin to ground to insure stability.
3	V_{IN}	The input pin of regulator. Typically a large storage capacitor ($0.15\Omega \leq ESR \leq 20\Omega$) is connected from this pin to ground to insure that the input voltage does not sag below the minimum dropout voltage during the load transient response. This pin must always be 1.3V higher than Vout in order for the device to regulate properly.

Absolute Maximum Rating (Note 1)

Symbol	Item	Rating (Note 2)	Units
V _I	Input Voltage	15	V
T _J	Operating Junction Temperature Range Control Section Power Transistor	0 ~ +125 0 ~ +150	°C
T _{STG}	Storage Temperature Range	-65 ~ +150	°C
T _L	Lead Temperature (Soldering, 10s)	+260	°C

Note 1: Absolute Maximum Ratings are those values beyond which the life of a device may be impaired.

Note 2: The values here show the absolute maximum rating, and for normal usage please refer the test condition in Electrical Characteristics Table.

Electrical Characteristics (Note 3)

Unless otherwise noted, these specifications apply over C_{IN} = 10μF, C_{OUT} = 10μF, and T_A=0°C to 70°C. Typical values refer to T_A=25°C.

Symbol	Parameter	Conditions	Min.	Typ.	Max.	Units
V _{REF}	Reference Voltage	T _J =0°C ~125°C, 10mA ≤ I _{OUT} ≤ 1A, 1.4V ≤ (V _{IN} - V _{OUT}) ≤ 10.75V	1.225	1.250	1.275	V
V _{OUT}	Output Voltage	EP1117-18 T _J =0°C ~125°C, 0 ≤ I _{OUT} ≤ 1.5A, 3.25V ≤ V _{IN} ≤ 9V	1.764	1.800	1.836	V
		EP1117-25 T _J =0°C ~125°C, 0 ≤ I _{OUT} ≤ 1A, 3.95V ≤ V _{IN} ≤ 9V	2.450	2.500	2.550	
		EP1117-33 T _J =0°C ~125°C, 0 ≤ I _{OUT} ≤ 1A, 4.75V ≤ V _{IN} ≤ 12V	3.235	3.300	3.365	
		EP1117-50 T _J =0°C ~125°C, 0 ≤ I _{OUT} ≤ 1A, 6.5V ≤ V _{IN} ≤ 12V	4.900	5.000	5.100	
REG _{LINE}	Line Regulation	EP1117-adj I _{OUT} =10mA, 1.5V ≤ (V _{IN} - V _{OUT}) ≤ 10.75V (Note4)		0.03	0.2	%
		EP1117-18 I _{OUT} =0A, 3.25V ≤ V _{IN} ≤ 9V (Note4)		1	6	mV
		EP1117-25 I _{OUT} =0A, 3.95V ≤ V _{IN} ≤ 9V (Note4)		1	6	
		EP1117-33 I _{OUT} =0A, 4.75V ≤ V _{IN} ≤ 12V (Note4)		1	6	
		EP1117-50 I _{OUT} =0A, 6.5V ≤ V _{IN} ≤ 12V (Note4)		1	10	

Electrical Characteristics (Continued) (Note 3)

Unless otherwise noted, these specifications apply over $C_{IN} = 10\mu F$, $C_{OUT} = 10\mu F$, and $T_A = 0^\circ C$ to $70^\circ C$. Typical values refer to $T_A = 25^\circ C$.

Symbol	Parameter		Conditions	Min.	Typ.	Max.	Units
REG _{LOAD}	Load Regulation	EP1117	$(V_{IN} - V_{OUT}) = 3V$, $0 \leq I_{OUT} \leq 1A$ (Note4)		0.1	0.4	%
		EP1117-18	$V_{IN} = 3.25V$, $0 \leq I_{OUT} \leq 1A$ (Note4)		1	10	mV
		EP1117-25	$V_{IN} = 3.95V$, $0 \leq I_{OUT} \leq 1A$ (Note4)		1	10	
		EP1117-33	$V_{IN} = 4.75V$, $0 \leq I_{OUT} \leq 1A$ (Note4)		1	10	
		EP1117-50	$V_{IN} = 6.5V$, $0 \leq I_{OUT} \leq 1A$ (Note4)		1	15	
V _D	Dropout Voltage		$I_{OUT} = 100mA$ $I_{OUT} = 500mA$ (Note5) $I_{OUT} = 1A$		1 1.05 1.1	1.1 1.2 1.3	V
I _{LIMIT}	Current Limit		$(V_{IN} - V_{OUT}) = 5V$, $T_J = 25^\circ C$	1.1			A
I _{FB}	FB Pin Current		$(V_{IN} - V_{OUT}) = 3V$, $I_{OUT} = 10mA$		60	120	μA
ΔI_{FB}	FB Pin Current Change		$10mA \leq I_{OUT} \leq 1A$, $1.4V \leq (V_{IN} - V_{OUT}) \leq 10.75V$		0.2	5	μA
I _O	Minimum Load Current		$(V_{IN} - V_{OUT}) = 10.75V$ (Note6)		5	10	mA
PSRR	Ripple Rejection		$f_{RIPPLE} = 120Hz$, $V_{RIPPLE} = 1VP-P$, $(V_{IN} - V_{OUT}) = 3V$	60	75		dB
T _R	Thermal Regulation		$T_J = 25^\circ C$, 30ms Pulse		0.01	0.02	%/W
T _S	Temperature Stability				0.5		%
L _S	Long-Term Stability		$T_J = 125^\circ C$, 1000Hrs		0.3		%
V _N	RMS Output Noise		$T_J = 25^\circ C$, $10Hz \leq F \leq 10KHz$, (% of V _{OUT})		0.003		%
θ_{th}	Thermal Resistance		Junction to case, at Tab junction to ambient		15		$^\circ C/W$
θ_{JA}	Thermal Resistance	SOT-223	Junction-to-Ambient (No heat sink ;No air flow)		117		$^\circ C/W$
		TO-252			92		
OT	Over Temperature Point				150		$^\circ C$

Note 3: 100% production test at +25°C. Specifications over the temperature range are guaranteed by design and characterization.

Note 4: See thermal regulation specifications for changes in output voltage due to heating effects. Load line regulations are measured at a constant junction temperature by low duty cycle pulse testing.

Note 5: Dropout voltage is specified over the full output current range of the device. Dropout voltage is defined as the minimum input/output differential measured at the specified output current. Test points and limits are also shown on the Dropout Voltage Curve.

Note 6: Minimum load current is defined as the minimum output current required to maintain regulation.

Typical Performance Characteristics

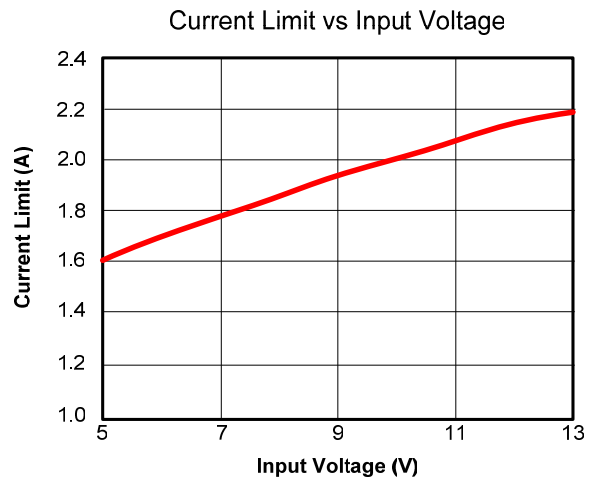
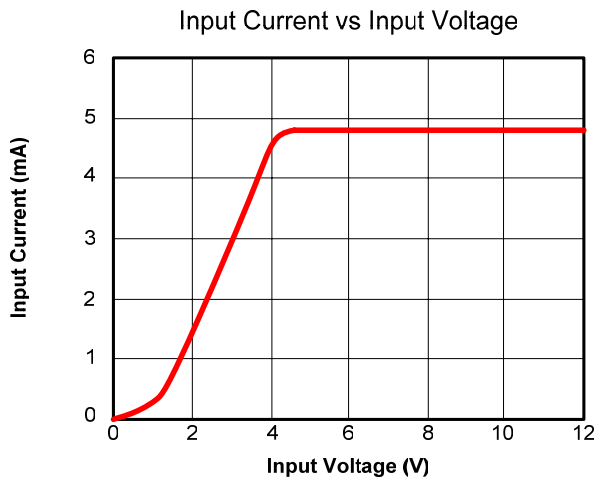
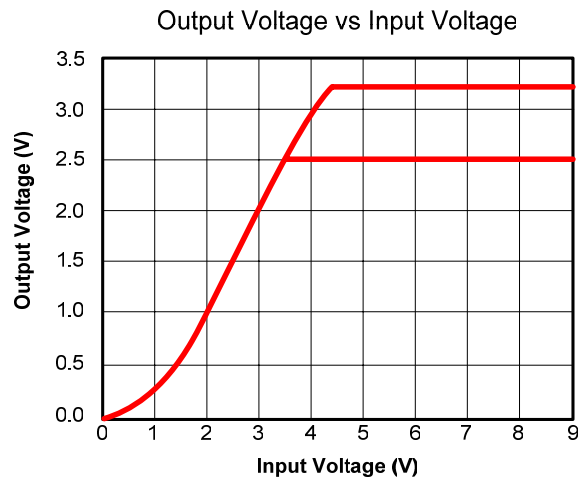
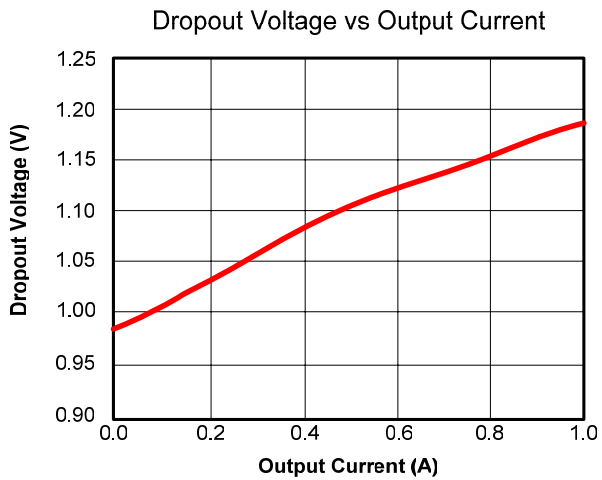

Functional Block Diagram

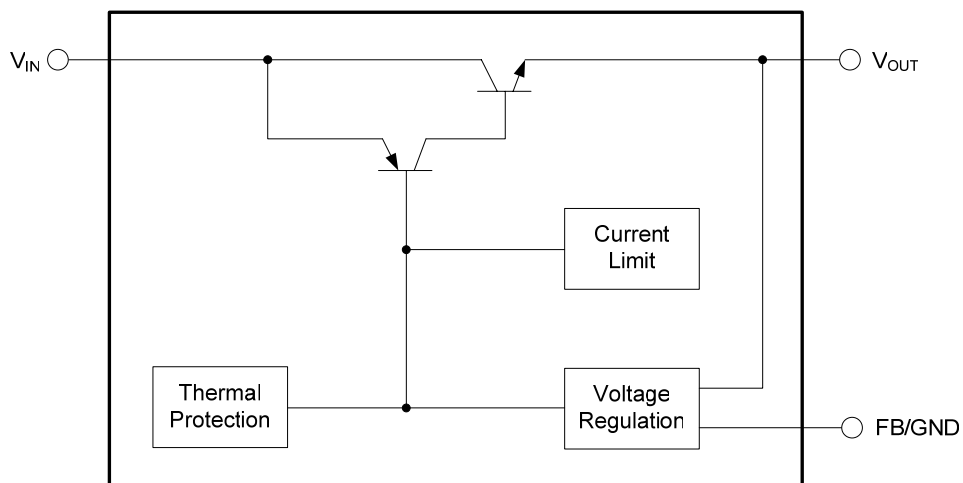

Output Voltage

The EP1117 develops a 1.25V reference voltage between the output and the FB terminal. By placing a resistor between these two terminals, a constant current is caused to flow through R1 and down through R2 to set the overall output voltage. Normally this current is chosen to be the specified minimum load current of 10mA. For fixed voltage devices R1 and R2 are included in the device.

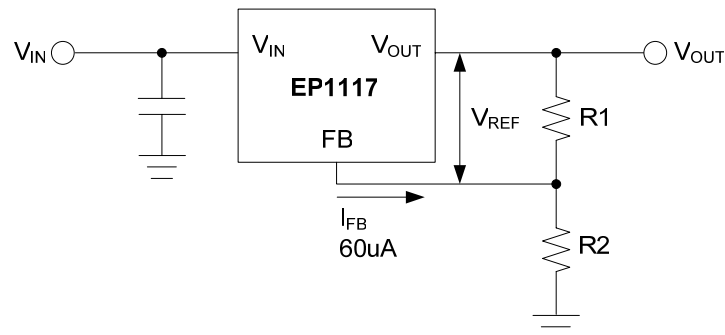

$$V_{OUT} = V_{REF} \times \left(1 + \frac{R2}{R1} \right) + I_{FB}R2$$

Figure 1-Basic Adjustable Regulator

Load Regulation

When the adjustable regulator is used, load regulation will be limited by the resistance of the wire connecting the regulator to the load. The datasheet specification for load regulation is measured at the output pin of the EP1117. Best load regulation is obtained when the top of the resistor divider (R1) is tied directly to the output pin of the device, not to the load. For fixed voltage devices, the top of R1 is internally connected to the output, and the ground pin can be connected to low side of the load. If R1 were connected to the load, R_p is multiplied by the divider ratio, the effective resistance between the regulator and the load would be: $R_p \times (1 + R2/R1)$, where R_p is Parasitic Line Resistance.

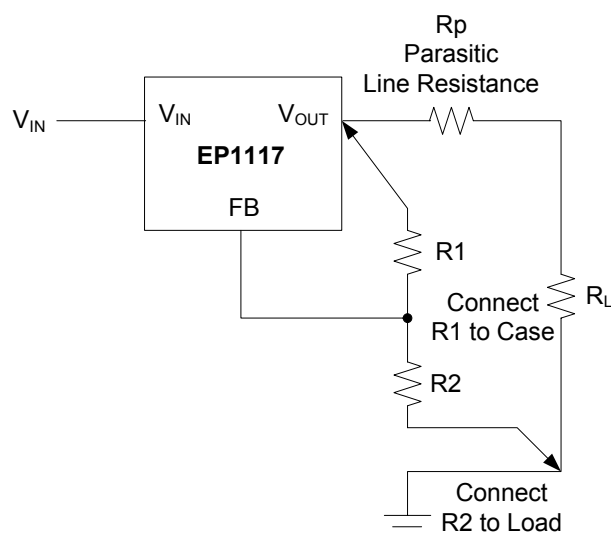

Figure 2-Connections for Best Load Regulation

Input Capacitor

An input capacitor of 10 μ F or greater is recommended. Tantalum or aluminum electrolytic capacitors can be used for bypassing. Larger Values will improve ripple rejection by bypassing the input to the regulator.

Output Capacitor

The EP1117 requires an output capacitor to maintain stability and improve transient response. The EP1117 output capacitor selection is dependent upon the ESR (equivalent series resistance) of the output capacitor to maintain stability. When the output capacitor is 10 μ F or greater, the output capacitor should have an ESR less than 1 Ω . This will improve transient response as well as promote stability. A low-ESR solid Tantalum capacitor works extremely well and provides good transient response and stability over temperature. Aluminum electrolytes can also be used, as long as the ESR of the capacitor is less than 1 Ω . The value of the output capacitor can be increased without limit. Higher capacitance values help to improve transient response and ripple rejection and reduce output noise.

Ripple Rejection

The curves for Ripple Rejection were generated using an adjustable device with the FB pin bypassed. With a 22 μ F bypassing capacitor 75dB ripple rejection is obtainable at any output level. The impedance of the FB pin capacitor, at the ripple frequency, should be <R1. R1 is normally in the range of 100 Ω -200 Ω . The size of the required FB pin capacitor is a function of the input ripple frequency. At 120Hz, with R1=100 Ω , the FB pin capacitor should be 13 μ F. For fixed voltage devices, and adjustable devices without a FB pin capacitor, the output ripple will increase as the ratio of the output voltage to the reference voltage (V_{OUT}/V_{REF}).

Thermal Considerations

The EP1117 regulators have thermal protection to limit junction temperature to 150 $^{\circ}$ C. However, device functionality is only guaranteed to a maximum junction temperature of +125 $^{\circ}$ C. A heat sink may be required depending on the maximum power dissipation and maximum ambient temperature of the application. Figure 3 and 4 show for the SOT-223 and TO-252 the measured values $\theta_{(JA)}$ for different copper area sizes using a 2 layers, 1.6mm, and 6Sq. cm FR-4 PCB with 2oz. copper and a ground plane layer on the backside area used for heat sinking. It can be used as a rough guideline in estimating thermal resistance. Both the SOT-223 and TO-252 packages use a copper plane on the PCB and the PCB itself as a heat sink. To optimize the heat sinking ability of the plane and PCB, solder the tab of the package to the plane.

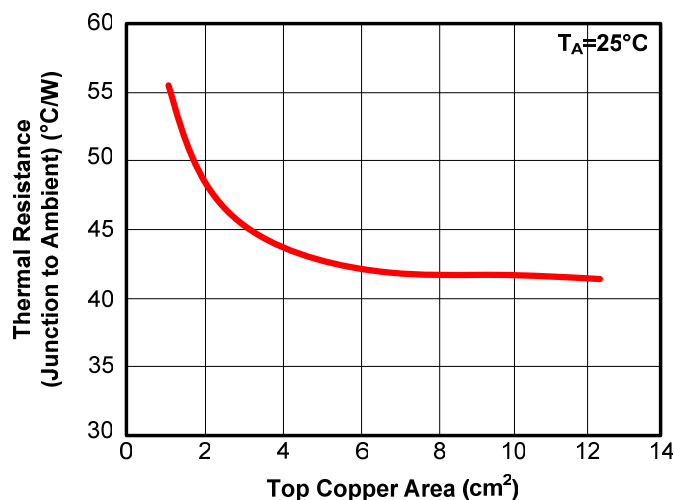

Figure 3- $\theta_{(JA)}$ vs copper area for SOT-223 package

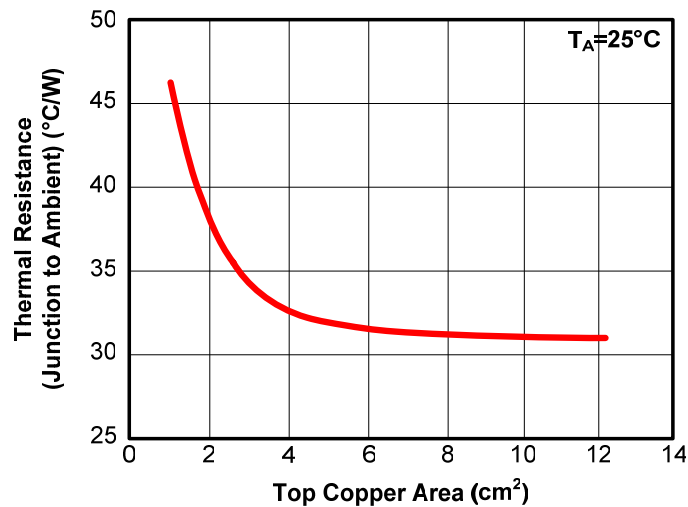

Figure 4- $\theta_{(JA)}$ vs copper area for TO-252 package

The thermal resistance for each application will be affected by thermal interactions with other components on the board. Some experimentation will be necessary to determine the actual value.

The power dissipation of EP1117 is equal to: $PD = (V_{IN} - V_{OUT}) \times I_{OUT}$

Maximum junction temperature is equal to: $T_{JUNCTION} = T_{AMBIENT} + (PD \times \theta_{(JA)})$

Note: $T_{JUNCTION}$ must not exceed 125°C

Safe Operation Area

Using the experiment result of previous Thermal Consideration (choose the one with 1.5cm*1.5cm polygene area) and $\theta_{(JA)}=50^{\circ}C/W$ spec, the safe operation area of EP1117 in SOT-223 and TO-252 packages can be obtained as Figure 5.

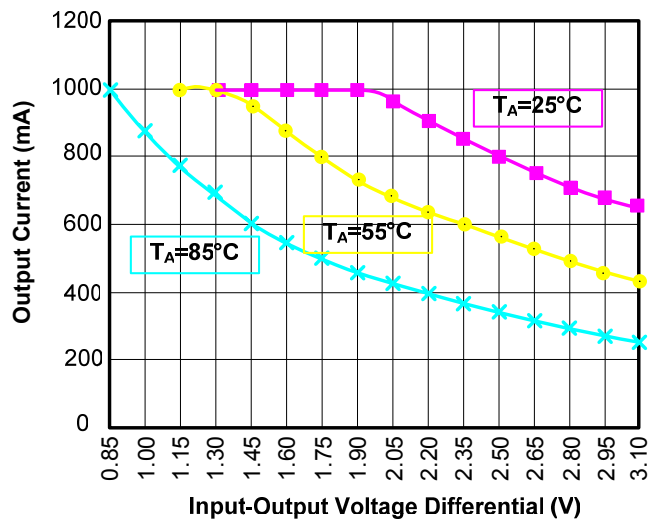
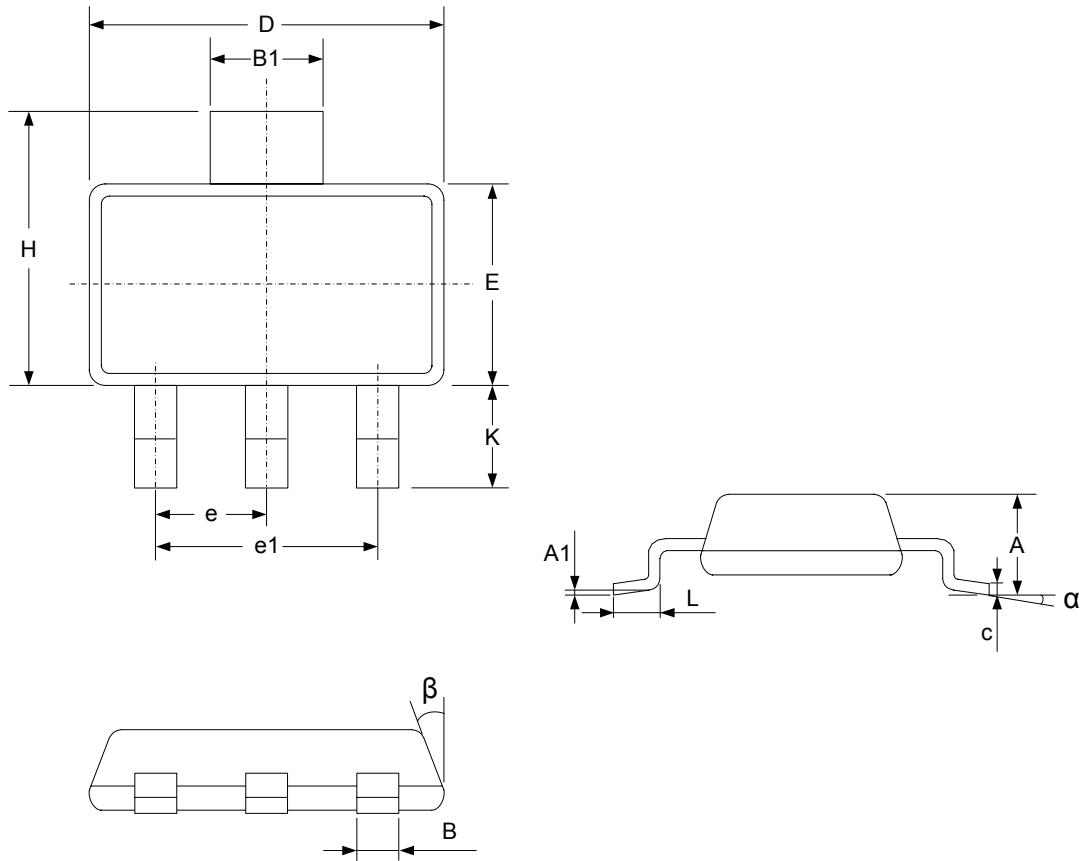

Figure 5-Safe Operation Area of EP1117 in SOT-223 and TO-252 packages (Limited by Power Dissipation with $T_{JUNCTION} < 125^{\circ}C$)

Package Description

SOT-223 (Reference JEDEC Registration SOT-223)



DIM	MILLIMETERS			INCHES		
	MIN.	NOM.	MAX.	MIN.	NOM.	MAX.
A	1.50	–	1.80	0.059	–	0.070
A1	0.02	–	0.08	0.001	–	0.003
B	0.60	–	0.80	0.023	–	0.031
B1	2.90	–	3.10	0.113	–	0.121
c	0.28	–	0.32	0.011	–	0.012
D	6.30	–	6.70	0.246	–	0.261
E	3.30	–	3.70	0.129	–	0.144
e	2.30 REF.			0.090 REF.		
e1	4.60 REF.			0.179 REF.		
H	6.70	–	7.30	0.261	–	0.285
L	0.91	–	1.10	0.035	–	0.043
K	1.50	–	2.00	0.059	–	0.078
α	0°	–	10°	0°	–	10°
β	13°			13°		

Package Description (Continued)

TO-252

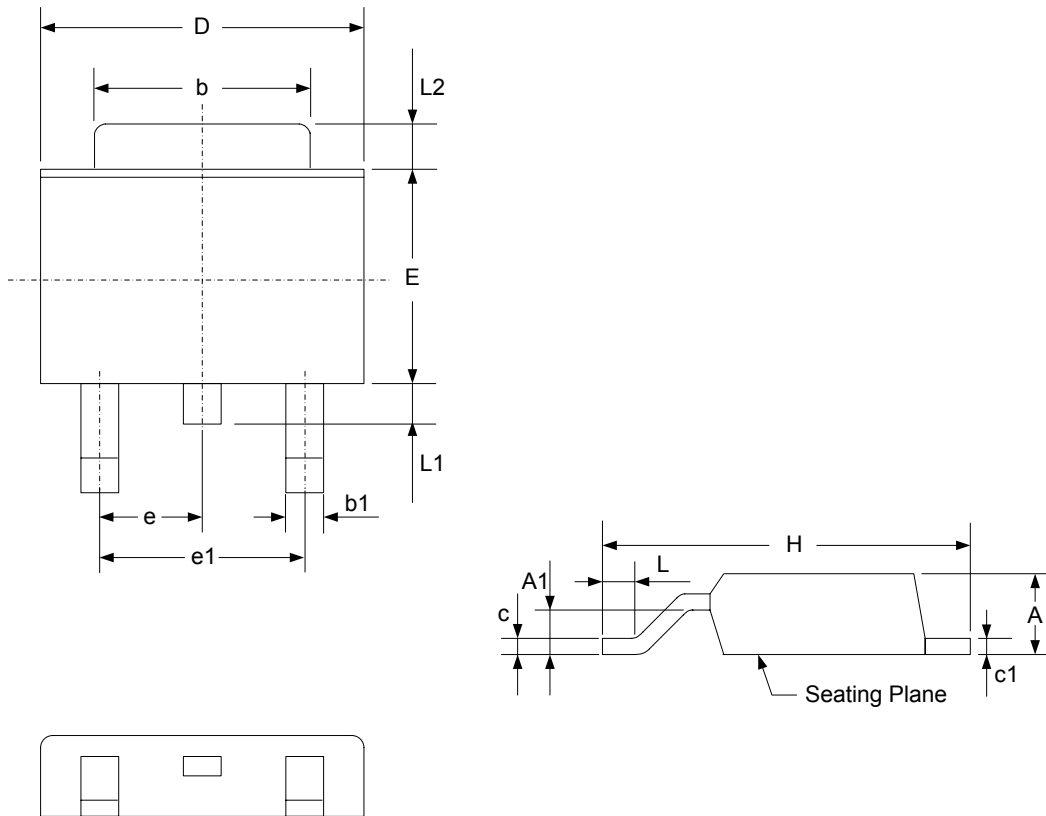

DIM	MILLIMETERS			INCHES		
	MIN.	NOM.	MAX.	MIN.	NOM.	MAX.
A	2.18	2.29	2.40	0.086	0.090	0.094
A1	0.89	-	1.14	0.035	-	0.045
b	5.20	5.35	5.50	0.205	0.211	0.217
b1	0.61 TYP.			0.024 TYP.		
c	0.45	0.52	0.58	0.018	0.020	0.023
c1	0.45	0.52	0.58	0.018	0.020	0.023
D	6.35	6.58	6.80	0.250	0.259	0.268
E	5.40	5.57	6.20	0.213	0.219	0.244
e	2.28 REF.			0.090 REF.		
e1	4.57 REF.			0.180 REF.		
H	9.00	9.70	10.40	0.354	0.382	0.409
L	0.51	-	-	0.020	-	-
L1	0.64	0.83	1.02	0.025	0.033	0.040
L2	0.88	-	1.27	0.035	-	0.050