



Triple Debounce Circuit

Description

The ELM410 provides all of the necessary circuitry to connect as many as three independent mechanical contacts to an electronic circuit.

All mechanical contacts, whether from switches, relays, etc. will have inherent 'bounce' when they make or break a connection. Depending on the type of switch, this fluctuation can be quite pronounced, often being interpreted as multiple inputs by high speed digital circuits.

This circuit provides all of the logic required to remove the bounce from most mechanical sources, without the use of additional components. As well, internal pull-up resistors have been provided so that the switch inputs can be directly connected to the 8 pin package.

The ELM410 provides three separate inverters which follow the input directly. No latching or 'memory action' is provided, as it is in the case of the ELM411.

Features

- Low power CMOS design - typically 1mA at 5V
- Wide supply range - 3.0 to 5.5 volt operation
- Simultaneous monitoring of three circuits
- Full 25msec debounce period on contact closure and opening, without external components
- Internal pullup resistors for contact monitoring
- High current drive outputs - up to 25 mA
- Can be cascaded to provide sequential outputs

Applications

- Pushbutton interface for logic circuits
- Limit switch monitoring
- Time delay generation

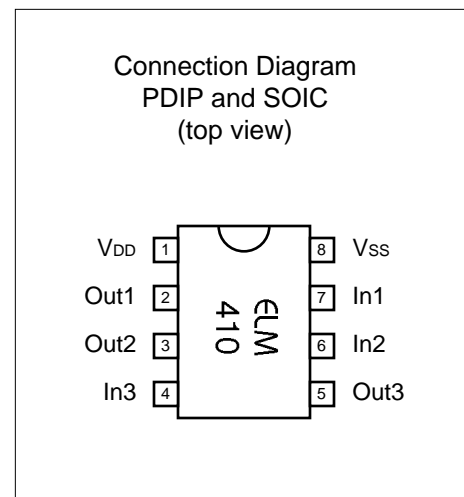

Block Diagram

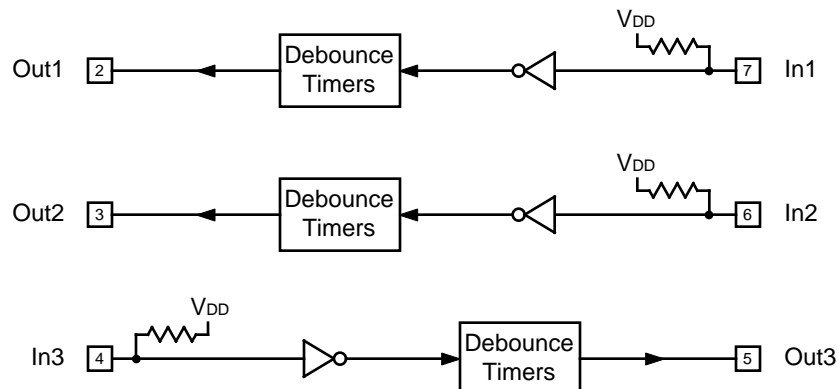



Pin Descriptions

V_{DD} (pin 1)

This pin is the positive supply pin, and should always be the most positive point in the circuit. Internal circuitry connected to this pin is used to provide power on reset of the microprocessor, so an external reset signal is not required. Refer to the Electrical Characteristics section for further information.

CMOS, not schmitt trigger, so the use of external delay capacitors, etc. is not recommended. An internal pullup resistor is provided to allow direct interface to mechanical contacts (refer to the specs for further information).

Out1 (pin 2)

This is the output pin for the first debounce circuit. A logic low applied to pin 7 will cause this pin to go to a logic high level, once the input is stable for the debounce period. Similarly, a logic high (or open circuit) at pin 7 will result in this pin being driven to a logic low level after the debounce period.

Out3 (pin 5)

This is the output pin for the third debounce circuit. Refer to the description for pin 2.

Out2 (pin 3)

This is the output pin for the second debounce circuit. Refer to the description for pin 2.

In2 (pin 6)

This is the input pin for the second debounce circuit. Refer to the description for pin 4.

In3 (pin 4)

This is the input for circuit 3. Levels are standard

In1 (pin 7)

This is the input pin for the first debounce circuit. Refer to the description for pin 4.

V_{SS} (pin 8)

Circuit common is connected to this pin. This is the most negative point in the circuit.

Ordering Information

These integrated circuits are available in either the 300 mil plastic DIP format, or in the 200 mil SOIC surface mount type of package. To order, add the appropriate suffix to the part number:

300 mil Plastic DIP..... ELM410P

200 mil SOIC..... ELM410SM

All rights reserved. Copyright ©1999 Elm Electronics.

Every effort is made to verify the accuracy of information provided in this document, but no representation or warranty can be given and no liability assumed by Elm Electronics with respect to the accuracy and/or use of any products or information described in this document. Elm Electronics will not be responsible for any patent infringements arising from the use of these products or information, and does not authorize or warrant the use of any Elm Electronics product in life support devices and/or systems. Elm Electronics reserves the right to make changes to the device(s) described in this document in order to improve reliability, function, or design.



Absolute Maximum Ratings

Storage Temperature..... -65°C to +150°C
 Ambient Temperature with
 Power Applied.....-40°C to +85°C
 Voltage on V_{DD} with respect to V_{SS}..... 0 to +7.5V
 Voltage on any other pin with
 respect to V_{SS}..... -0.6V to (V_{DD} + 0.6V)

Note:

Stresses beyond those listed here will likely damage the device. These values are given as a design guideline only. The ability to operate to these levels is neither inferred nor recommended.

Electrical Characteristics

All values are for operation at 25°C and a 5V supply, unless otherwise noted. For further information, refer to note 1 below.

Characteristic	Minimum	Typical	Maximum	Units	Conditions
Supply Voltage, V _{DD}	3.0	5.0	5.5	V	
V _{DD} rate of rise	0.05			V/ms	see note 2
Average Supply Current, I _{DD}		1.0	2.4	mA	V _{DD} = 5V, see note 3
Internal pullup resistances (see note 4)	300 20	500 30	600 50	KΩ KΩ	Pin 4 - Input 3 Pins 6 & 7 - Inputs 1 & 2
Debounce Period		25		msec	see note 5
Input low voltage	V _{SS}		0.15 V _{DD}	V	
Input high voltage	0.85 V _{DD}		V _{DD}	V	
Output low voltage			0.6	V	Current (sink) = 8.7mA
Output high voltage	V _{DD} - 0.7			V	Current (source) = 5.4mA

Notes:

1. This integrated circuit is produced with a Microchip Technology Inc.'s PIC12C5XX as the core embedded microcontroller. For further device specifications, and possibly clarification of those given, please refer to the appropriate Microchip documentation.
2. This spec must be met in order to ensure that a correct power on reset occurs. It is quite easily achieved using most common types of supplies, but may be violated if one uses a slowly varying supply voltage, as may be obtained through direct connection to solar cells, or some charge pump circuits.
3. Pullup resistor currents are not included in this figure.
4. The value of the internal pullup resistance is both supply and temperature dependent.
5. Time is approximate. The input must remain stable for this period before the output is allowed to change.

Example Application

Figure 1 shows the ELM410 used to interface two momentary action normally open pushbutton switches to an ELM310 in a manually controlled stepping motor circuit. For simplicity, the stepper motor and its drive transistors are not shown on this diagram.

Using the ELM310 to control a stepper motor has many advantages - low cost, low power, ease of use, etc. There is one disadvantage however, in that the integrated circuit is capable of responding quite quickly to inputs. This would result in multiple steps of the motor, and perceived erratic operation, if the input were connected directly to a switch, and not debounced by a circuit such as the ELM410.

The circuit below shows how easily two control switches can be debounced and used to control the ELM310. The two switches are simply connected between V_{SS} and their respective inputs, allowing the internal pullup resistors to detect the state of the switch. Power is obtained from the circuit being connected to, providing the correct logic drive levels. Finally, the unused debounce circuit is simply left with no

connection to it. This is acceptable in this case, as the internal pullup resistor will prevent the input to circuit 3 from floating.

Another variation on this circuit would have been to invert the direction control input by connecting pin 3 to pin 4 on the ELM410, then use pin 5 to drive pin 3 of the ELM310. This would have resulted in the direction pushbutton causing a counter-clockwise rotation when pressed due to the double inversion from the two debounce circuits connected in series.

For more permanent installations, consideration should be given to protecting the ELM410 from electrostatic discharges, etc. by providing series current limiting resistors, and additional pullup resistors. For typical usage in prototyping and experimenter circuits, however, nothing more than is shown below would normally be required.

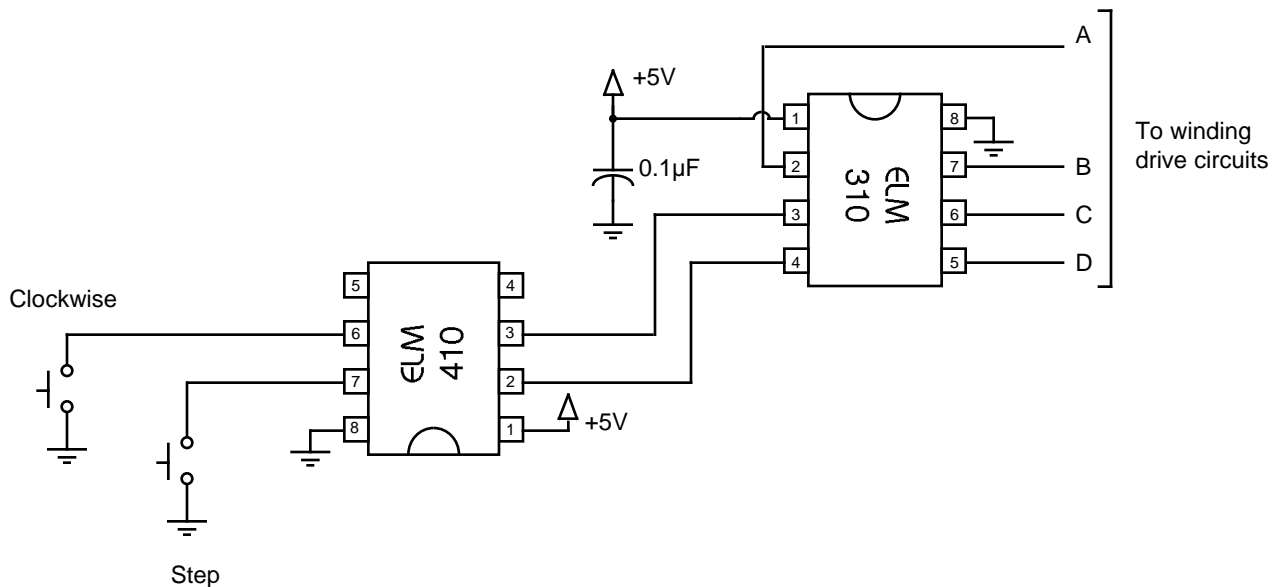

Figure 1. Manual Control of a Stepper Motor