



VG-PD6729

PCI-to-PC Card (PCMCIA) Controller

Datasheet

The VG-PD6729 is a single-chip PC Card (PCMCIA) controller solution capable of controlling two fully independent PCMCIA sockets. The chip is fully PCMCIA-2.1 and JEIDA-4.1 compliant and is optimized for use in embedded applications and notebook/handheld/mobile computer systems where reduced form factor and low power consumption are critical design objectives. With the VG-PD6729, a complete dual-socket PCMCIA solution with power-control logic can occupy less than 2 square inches (excluding connectors).

The VG-PD6729 chip employs energy-efficient, mixed-voltage technology that can reduce system power consumption by over 50 percent. The chip also provides a Suspend mode, which stops the internal clock, and an automatic Low-power Dynamic mode, which stops transactions on the PCMCIA bus, stops internal clock distribution, and turns off much of the internal circuitry.

PC applications typically access PC cards through the socket/card-services software interface. To assure full compatibility with existing socket/card-services software and PC-card applications, the register set in the VG-PD6729 is a superset of the Intel® 82365SL register set.

The chip provides fully buffered PCMCIA interfaces, meaning that no external logic is required for buffering signals to/from the interface, and power consumption can be controlled by limiting signal transitions on the PCMCIA bus.

Lead-Free (RoHS compliant) version is also available.



PCI-to-PC Card (PCMCIA) Host Controller – VG-PD6729

Information in this document is provided in connection with Amphus® products. No license, express or implied, by estoppel or otherwise, to any intellectual property rights is granted by this document. Except as provided in Amphus' Terms and Conditions of Sale for such products, Amphus assumes no liability whatsoever, and Amphus disclaims any express or implied warranty, relating to sale and/or use of Amphus products including liability or warranties relating to fitness for a particular purpose, merchantability, or infringement of any patent, copyright or other intellectual property right. Amphus products are not intended for use in medical, life saving, or life sustaining applications.

Amphus may make changes to specifications and product descriptions at any time, without notice.

Designers must not rely on the absence or characteristics of any features or instructions marked "reserved" or "undefined." Amphus reserves these for future definition and shall have no responsibility whatsoever for conflicts or incompatibilities arising from future changes to them. The VG-PD6729 may contain design defects or errors known as errata which may cause the product to deviate from published specifications. Current characterized errata are available on request.

Contact your local Amphus sales office or your distributor to obtain the latest specifications and before placing your product order.

Copies of documents which have an ordering number and are referenced in this document, or other Amphus literature may be obtained by calling (408) 850-1159 (main phone/fax), (408) 850-1179 (sales), by visiting Amphus' website at <http://www.amphus.com>, or by sending email to Amphus.Sales@amphus.com.

Copyright © Amphus Corporation, 2006

*Third-party brands and names are the property of their respective owners.



Contents

1.0	General Conventions	11
2.0	Pin Information	12
2.1	Pin Diagram.....	13
2.2	Pin Description Conventions	13
2.3	Pin Descriptions.....	15
3.0	Introduction to the VG-PD6729	23
3.1	System Architecture	23
3.1.1	PCMCIA Basics.....	23
3.1.2	VG-PD6729 Windowing Capabilities	23
3.1.3	Zoomed Video Port	26
3.1.4	Interrupts	27
3.1.5	VG-PD6729 Power Management	29
3.1.6	Socket Power Management Features	30
3.1.7	Write FIFO.....	31
3.1.8	Bus Sizing	31
3.1.9	Programmable PCMCIA Timing	31
3.1.10	ATA Mode Operation.....	31
3.1.11	VS1 and VS2.....	31
3.2	Host Access to Registers	31
3.3	Power-On Setup.....	33
4.0	Register Description Conventions	34
5.0	PCI-Configuration Registers	36
5.1	Vendor ID and Device ID.....	36
5.2	Command and Status.....	37
5.3	Revision ID and Class Code	39
5.4	Cache Line Size, Latency Timer, Header Type, and BIST.....	40
5.5	Base Address 0	41
5.6	Interrupt Line, Interrupt Pin, Min_Gnt, and Max_Lat	42
6.0	Operation Registers	43
6.1	Index.....	43
6.2	Data.....	47
7.0	Device Control Registers	48
7.1	Chip Revision	48
7.2	Interface Status	49
7.3	Power Control.....	50
7.4	Interrupt and General Control.....	52
7.5	Card Status Change.....	54
7.6	Management Interrupt Configuration.....	55
7.7	Mapping Enable	57
8.0	I/O Window Mapping Registers	60
8.1	I/O Window Control	60



8.2	System I/O Map 0-1 Start Address Low	61
8.3	System I/O Map 0-1 Start Address High	62
8.4	System I/O Map 0-1 End Address Low	62
8.5	System I/O Map 0-1 End Address High	63
8.6	Card I/O Map 0-1 Offset Address Low	63
8.7	Card I/O Map 0-1 Offset Address High	64
9.0	Memory Window Mapping Registers	65
9.1	System Memory Map 0-4 Start Address Low.....	65
9.2	System Memory Map 0-4 Start Address High.....	66
9.3	System Memory Map 0-4 End Address Low.....	67
9.4	System Memory Map 0-4 End Address High.....	67
9.5	Card Memory Map 0-4 Offset Address Low.....	68
9.6	Card Memory Map 0-4 Offset Address High.....	69
10.0	Extension Registers.....	70
10.1	Misc Control 1	70
10.2	FIFO Control	71
10.3	Misc Control 2	72
10.4	Chip Information.....	74
10.5	ATA Control.....	74
10.6	Extended Index	76
10.7	Extended Data	77
	10.7.1 Extension Control 1	77
	10.7.2 System Memory Map 0-4 Upper Address	78
	10.7.3 Misc Control 3	79
10.8	Device Identification and Implementation Scheme	79
	10.8.1 Mask Revision Byte.....	80
	10.8.2 Product ID Byte	80
	10.8.3 .Device Capability Byte A.....	81
	10.8.4 Device Capability Byte B	82
	10.8.5 Device Implementation Byte A.....	82
	10.8.6 Device Implementation Byte B.....	83
	10.8.7 .Device Implementation Byte C.....	84
	10.8.8 Device Implementation Byte D.....	85
	10.8.9 External Data (Index 6Fh)	86
11.0	Timing Registers	87
11.1	Setup Timing 0-1	87
11.2	Command Timing 0-1.....	88
11.3	Recovery Timing 0-1	89
12.0	ATA Mode Operation	91
13.0	Electrical Specifications.....	93
13.1	Absolute Maximum Ratings	93
13.2	DC Specifications.....	93
13.3	AC Timing Specifications	96
	13.3.1 PCI Bus Timing	96
	13.3.2 System Interrupt Timing	100
	13.3.3 PCMCIA Bus Timing Calculations.....	101
	13.3.4 PCMCIA Bus Timing	102



14.0 Package Dimensions 108

14.1 208-Pin MQFP Package Outline Drawing 108

14.2 208-Pin LQFP Package Outline Drawing 109

15.0 Ordering Information 110

Bit Index 111

Figures

1 System Block Diagram 9

2 PC Card Controller Form Factor 10

3 VG-PD6729 Pin Diagram 13

4 Memory Window Organization 25

5 I/O Window Organization 26

6 A Typical ZV Port Implementation 27

7 A Common Mapping of VG-PD6729 Interrupt Pins to System Interrupt Signals 28

8 Indexed 8-Bit Register Structure 32

9 Indexed 8-Bit Register Example 32

10 Operation Registers as PCI Double-Word I/O Space at Base Address 0 Register (programmed at offset 10h) 43

11 Socket/Register Index Space 44

12 Pulse Mode Interrupts 71

13 FRAME#, AD[31:0], C/BE[3:0]#, and DEVSEL# (PCI™ Bus) 97

14 IDSEL Timing in a Configuration Cycle (PCI™ Bus) 99

15 PAR Timing (PCI™ Bus) 100

16 Pulse Mode Interrupt Timing 100

17 Memory Read/Write Timing 102

18 Word I/O Read/Write Timing 104

19 PCMCIA Read/Write Timing when System is 8 Bit (SBHE Tied High) 105

20 Normal Byte Read/Write Timing (that is, all other byte accesses, including odd I/O cycles where -IOIS16 is low) 106

21 16-Bit System to 8-Bit I/O Card: Odd Byte Timing 107

Tables

1 PCI Bus Interface Pins 15

2 Socket Interface Pins 18

3 Power Control and General Interface Pins 20

4 Power, Ground, and No-Connect Pins 21

5 Pin Usage Summary 22

6 VG-PD6729 Power-Management Modes 30

7 Index Registers 44

8 Enabling of Socket Power Controls 51

9 Enabling of Output Signals to Socket 51

10 Bit 5: Pull-Up Control 78



PCI-to-PC Card (PCMCIA) Host Controller – VG-PD6729

11	ATA Pin Cross-Reference	91
12	General DC Specifications	93
13	PCMCIA Bus Interface DC Specifications.....	93
14	PCI Bus Interface DC Specifications.....	94
15	Power Control Interface (+5V Powered) DC Specifications	95
16	Operating Current Specifications (3.3V)	95
17	Operating Current Specifications (5.0V)	95
18	Index of AC Timing Specifications	96
19	FRAME#, AD[31:0], C/BE[3:0]#, and DEVSEL#	96
20	TRDY# and STOP# Delay	98
21	TRDY# and STOP# Delay (PCI™ Bus)	98
22	IDSEL Timing in a Configuration Cycle	98
23	PAR Timing	99
24	Pulse Mode Interrupt Timing	100
25	Memory Read/Write Timing	102
26	Word I/O Read/Write Timing	103
27	PCMCIA Read/Write Timing when System is 8-Bit.....	104
28	Normal Byte Read/Write Timing.....	105
29	16-Bit System to 8-Bit I/O Card: Odd Byte Timing	106



Revision History

Revision	Date	Description
1.0	01/01/2006	Initial release.



Product Features

- Single-chip PC Card controller
- Direct connection to PCI bus
- Direct connection of two PCMCIA sockets ZV Port support for multimedia applications
- Compliant with PCI 2.1
- Compliant with PCMCIA 2.1 and JEIDA 4.1
- 82365SL-compatible register set, ExCA™-compatible
- Automatic Low-power Dynamic mode for lowest power consumption
- Programmable Suspend mode
- PCMCIA-ATA and true IDE disk interface support
- Five programmable memory windows per socket
- Two programmable I/O windows per socket
- Programmable card access cycle timing
- 8- or 16-bit PCMCIA card support
- ATA disk interface support
- Automatic flash memory timing support
- 3.3V, 5V, or mixed 3.3/5V operation supports PCMCIA low-voltage card specification
- Multiple VG-PD6729s can be used on the PCI bus without external hardware
- 208-pin MQFP

Figure 1. System Block Diagram

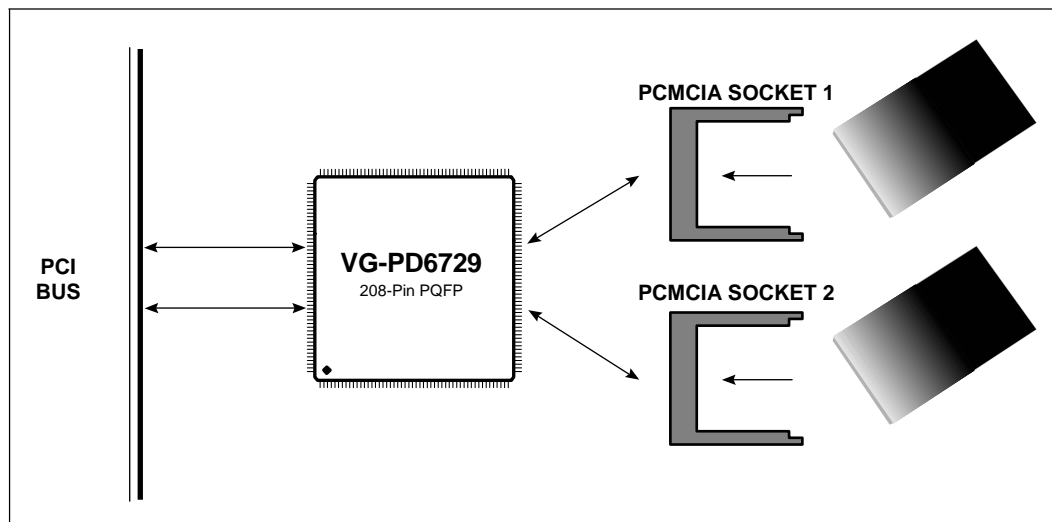

Embedded Systems Design Priorities	Supporting Features
<ul style="list-style-type: none"> • Small Form Factor 	Single-chip solution No external buffers for host or socket interfacing Efficient board layout

PCI-to-PC Card (PCMCIA) Host Controller – VG-PD6729

Embedded Systems Design Priorities	Supporting Features
<ul style="list-style-type: none"> • Minimum Power Consumption 	Automatic Low-power Dynamic mode Suspend mode Mixed-voltage operation
<ul style="list-style-type: none"> • High Performance 	Write FIFO Programmable timing supports more cards, faster reads and writes
<ul style="list-style-type: none"> • Hardware and Software Compatibility 	Compliant with PCMCIA 2.1 and JEIDA 4.1 Compliant with PCI 2.0 82365SL A-step register-compatible, ExCA™-compatible

Figure 2. PC Card Controller Form Factor

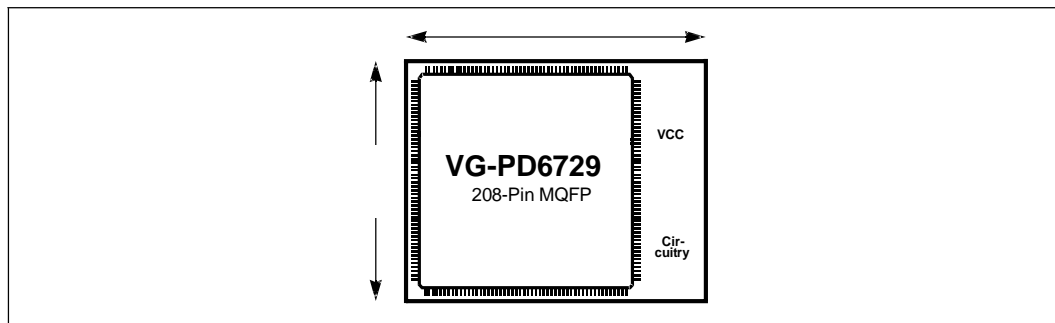



1.0 General Conventions

The following general conventions apply to this document.

Bits within words and words within various memory spaces are generally numbered with a 0 (zero) as the least-significant bit or word. For example, the least-significant bit of a byte is bit 0, while the most-significant bit is bit 7.

In addition, number ranges for bit fields and words are presented with the most-significant value first. Thus, when discussing a bit field within a register, the bit number of the most-significant bit is written first, followed by a hyphen (-) and then the bit number of the least-significant bit; as in, bits 7-0.

In this document, the names of the VG-PD6729 internal registers are bold-faced. For example, **Chip Revision** and **Power Control** are register names. The names of bit fields are written with initial upper-case letters. For example, Card Power On and Battery Voltage Detect are bit field names.

Numbers and Units

The unit *Kbyte* designates 1024 bytes (2^{10}). The unit *Mbyte* designates 1,048,576 bytes (2^{20}). The unit *Gbyte* designates 1,073,741,824 bytes (2^{30}). The unit *Hz* designates hertz. The unit *kHz* designates 1000 hertz. The unit *MHz* designates 1,000,000 Hz. The unit *ms* designates millisecond. The unit μ s designates microsecond. The unit *ns* designates nanosecond. The unit *mA* designates milliamper. The unit *V* immediately following a number designates volt.

Hexadecimal numbers are presented with all letters in uppercase and a lowercase *h* appended. For example, *14h* and *03CAh* are hexadecimal numbers.

Binary numbers have the letter *b* appended to them or are enclosed in single quotation marks. For example, *11b* and '*11*' are binary numbers.

Numbers not indicated by an *h* or *b* are decimal.

In addition, a capital letter *X* is used within numbers to indicate digits ignored by the VG-PD6729 within the current context. For example, *101XX01b* is a binary number with bits 3-2 ignored.



2.0 Pin Information

The VG-PD6729 device is packaged in a 208-pin MQFP (metric quad flat pack) or VQFP (very-tight-pitch quad flat pack) component package. The interface pins can be divided into four groups:

- PCI bus interface pins
- PCMCIA socket interface pins (two sets)
- Power control and general interface pins
- Power, ground, and no-connect pins

Refer to [Figure 3](#) for the VG-PD6729 pin diagram. The pin assignments for the groups of interface pins are shown in [Table 1](#) through [Table 4](#).

2.1 Pin Diagram

Figure 3. VG-PD6729 Pin

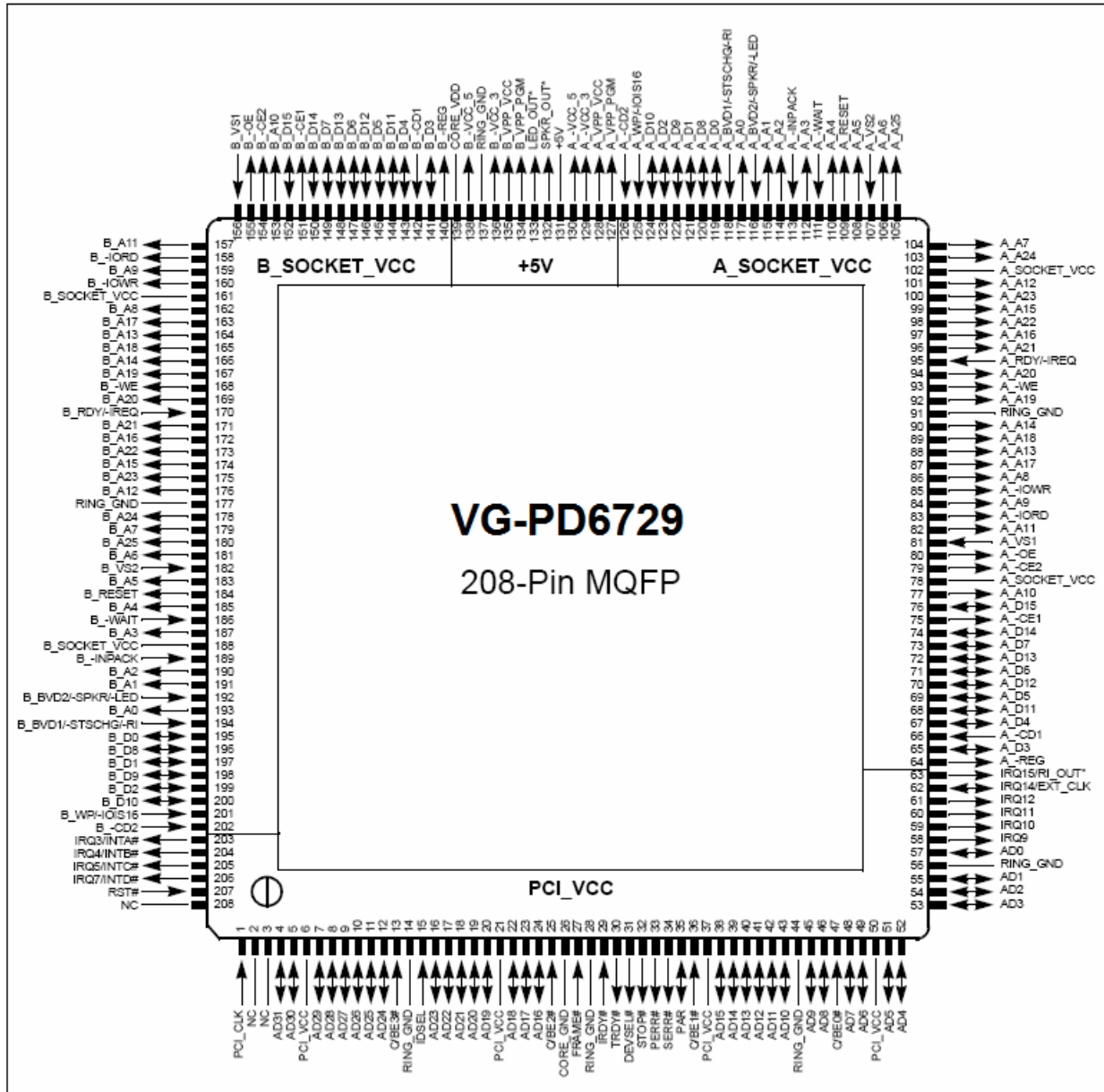

2.2 Pin Description Conventions

The following conventions apply to the pin description tables in “Pin Descriptions” on page 15:

- A pound sign (#) at the end of a pin name indicates an active-low signal for the PCI bus.
- A dash (-) at the beginning of a pin name indicates an active-low signal for the PCMCIA bus.



PCI-to-PC Card (PCMCIA) Host Controller – VG-PD6729

- An asterisk (*) at the end of a pin name indicates an active-low signal that is a general-interface for the VG-PD6729.
- Pins marked with a dagger (†) in the pin description tables can be switched between CMOS and TTL input levels when CORE_VDD is powered at 5 volts. All other pins use CMOS input levels when CORE_VDD is powered at 5 volts and TTL input levels when powered at 3.3 volts.
- A pin name ending in bracketed digits separated by a colon [n:n] indicates a multi-pin bus.
- The pin number (Pin Number) column indicates the package pin that carries the listed signal. Note that multi-pin buses are listed with the first pin number corresponding to the most-significant bit of the bus. For example, pin numbers 4-5, 7-12, 16-20, 22-24, 38-43, 45-46, 48-49, 51-55, and 57 associated with PCI Bus Address Input and Data Input/Output pins AD[31:0] indicate that:
 - AD[31] is pin 4
 - AD[1] is pin 55
 - AD[0] is pin 57
- The quantity (Qty.) column indicates the number of pins used (per socket where applicable).
- The I/O-type code (I/O) column indicates the input and output configurations of the pins on the VG-PD6729. The possible types are defined below.
- The power-type code (Pwr.) column indicates the output drive power source for an output pin or the pull-up power source for an input pin on the VG-PD6729. The possible types are defined below.

I/O Type	Description
I	Input pin
I-PU	Input pin with an internal pull-up resistor
O	Constant-driven, output pin
I/O	Input/output pin
OD	Open-drain output pin
TO	Three-state output pin
TO-PU	Three-state output pin with internal pull-up resistor
PW	Power or ground pin



Power Type	Output or Pull-up Power Source
1	+5V: powered from a 5-volt power supply (in most systems, see description of +5V pin in Table 4)
2	A_SOCKET_VCC: powered from the Socket A V _{CC} supply connecting to PCMCIA pins 17 and 51 of Socket A
3	B_SOCKET_VCC: powered from the Socket B V _{CC} supply connecting to PCMCIA pins 17 and 51 of Socket B
4	PCI_VCC: powered from the PCI bus power supply
5	available logic supply, which in most systems is 3.3 volts

Note: All pin inputs are referenced to CORE VDD, independently of their output supply voltage.

The drive-type (Drive) column describes the output drive-type of the pin (see DC specifications in “Electrical Specifications” on page 93 for more information). Note that the drive type listed for an input-only (I) pin is not applicable (-).

2.3 Pin Descriptions

Table 1. PCI Bus Interface Pins (Sheet 1 of 3)

Pin Name	Description	Pin Number	Qty.	I/O	Pwr.	Drive
AD[31:0]	PCI Bus Address Inputs / Data Input/Outputs: These pins connect to PCI bus signals AD[31:0].	4-5, 7-12, 16-20, 22-24, 38-43, 45-46, 48-49, 51-55, 57	32	I/O	4	PCI Spec.
C/BE[3:0]#	PCI Bus Command / Byte Enables: The command signalling and byte enables are multiplexed on the same pins. During the address phase of a transaction, C/BE[3:0]# are interpreted as the bus commands. During the data phase, C/BE[3:0]# are interpreted as byte enables. The byte enables are to be valid for the entirety of each data phase, and they indicate which bytes in the 32-bit data path are to carry meaningful data for the current data phase.	13, 25, 36, 47	4	I	-	-
FRAME#	Cycle Frame: This input indicates to the VG-PD6729 that a bus transaction is beginning. While FRAME# is asserted, data transfers continue. When FRAME# is deasserted, the transaction is at its final phase.	27	1	I	-	-
IRDY#	Initiator Ready: This input indicates the initiating agent's ability to complete the current data phase of the transaction. IRDY# is used in conjunction with TRDY#.	29	1	I	-	-



PCI-to-PC Card (PCMCIA) Host Controller – VG-PD6729

Table 1. PCI Bus Interface Pins (Sheet 2 of 3)

Pin Name	Description	Pin Number	Qty.	I/O	Pwr.	Drive
TRDY#	Target Ready: This output indicates the VG-PD6729's ability to complete the current data phase of the transaction. TRDY# is used in conjunction with IRDY#.	30	1	TO	4	PCI Spec.
STOP#	Stop: This output indicates the current target is requesting the master to stop the current transaction.	32	1	TO	4	PCI Spec.
IDSEL	Initialization Device Select: This input is used as a chip select during configuration read and write transactions. This is a point-to-point signal. The VG-PD6729 must be connected to its own unique IDSEL line (from the PCI bus arbiter or one of the high-order AD bus pins).	15	1	I	-	-
DEVSEL#	Device Select: The VG-PD6729 drives this output active (low) when it has decoded the PCI address as one that it is programmed to support, thereby acting as the target for the current PCI cycle.	31	1	TO	4	PCI Spec.
PERR#	Parity Error: The VG-PD6729 drives this output active (low) if it detects a data parity error during a write phase.	33	1	TO	4	PCI Spec.
SERR#	System Error: This output is pulsed by the VG-PD6729 to indicate an address parity error.	34	1	TO	4	PCI Spec.
PAR	Parity: This pin is sampled the clock cycle after completion of each corresponding address or write data phase. For read operations this pin is driven from the cycle after TRDY# is asserted until the cycle after completion of each data phase. It ensures even parity across AD[31:0] and C/BE[3:0]#.	35	1	TO	4	PCI Spec.
PCI_CLK	PCI Clock: This input provides timing for all transactions on the PCI bus to and from the VG-PD6729. All PCI bus interface signals described in this table (Table 1), except RST#, INTA#, INTB#, INTC#, and INTD#, are sampled on the rising edge of PCI_CLK; and all VG-PD6729 PCI bus interface timing parameters are defined with respect to this edge. This input can be operated at frequencies from 0 to 33 MHz.	1	1	I	-	-
RST#	Device Reset: This input is used to initialize all registers and internal logic to their reset states and place most VG-PD6729 pins in a high-impedance state.	207	1	I	-	-
IRQ15/ RI_OUT*	Interrupt Request 15 / Ring Indicate Out: This output can be used either as an interrupt output (usually the system's IRQ15 interrupt line), or if Misc Control 2 register bit 7 is a '1', as a ring indicate output from a socket's BVD1/-STSCHG/-RI input.	63	1	TO	4	2 mA
IRQ14/ EXT_CLK	Interrupt Request 14 / External Clock: This pin can be used either as an interrupt output (usually the system's IRQ14 interrupt line), or if Misc Control 2 register bit 0 is a '1', as an alternate external clock input that will provide the internal clock to the VG-PD6729 for PCMCIA cycle timing when the PCI bus is not active.	62	1	TO	4	2 mA



Table 1. PCI Bus Interface Pins (Sheet 3 of 3)

Pin Name	Description	Pin Number	Qty.	I/O	Pwr.	Drive
IRQ[12:9]	Interrupt Request: These outputs indicate programmable interrupt requests generated from any of a number of card actions. Although there is no specific mapping requirement for connecting interrupt lines from the VG-PD6729 to the system, a common use is to connect these pins to the corresponding signal name in the system.	61-58	4	O	4	2mA
IRQ3/INTA#	Interrupt Request 3 / PCI Bus Interrupt A: This output indicates a programmable interrupt request generated from any of a number of card actions. Although there is no specific mapping requirement for connecting interrupt lines from the VG-PD6729 to the system, a common use is to connect this pin to the system IRQ3 signal or to the PCI bus INTA# signal.	203	1	TO	4	PCI Spec.
IRQ4/INTB#	Interrupt Request 4 / PCI Bus Interrupt B: This output indicates a programmable interrupt request generated from any of a number of card actions. Although there is no specific mapping requirement for connecting interrupt lines from the VG-PD6729 to the system, a common use is to connect this pin to the system IRQ4 signal or to the PCI bus INTB# signal.	204	1	TO	4	PCI Spec.
IRQ5/INTC#	Interrupt Request 5 / PCI Bus Interrupt C: This output indicates a programmable interrupt request generated from any of a number of card actions. Although there is no specific mapping requirement for connecting interrupt lines from the VG-PD6729 to the system, a common use is to connect this pin to the system IRQ5 signal or to the PCI bus INTC# signal.	205	1	TO	4	PCI Spec.
IRQ7/INTD#	Interrupt Request 7 / PCI Bus Interrupt D: This output indicates a programmable interrupt request generated from any of a number of card actions. Although there is no specific mapping requirement for connecting interrupt lines from the VG-PD6729 to the system, a common use is to connect this pin to the system IRQ7 signal or to the PCI bus INTD# signal.	206	1	TO	4	PCI Spec.
PCI_VCC	PCI Bus V_{CC}: These pins can be connected to either a 3.3- or 5-volt power supply. The PCI bus interface pin outputs listed in this table (Table 1) will operate at the voltage applied to these pins, independent of the voltage applied to other VG-PD6729 pin groups.	6, 21, 37, 50	4	PW	-	-



PCI-to-PC Card (PCMCIA) Host Controller – VG-PD6729

Table 2. Socket Interface Pins (Sheet 1 of 3)

Pin Name	Description	Pin Number		Qty.	I/O	Pwr.	Drive
		Socket A	Socket B				
-REG	Register Access: In Memory Card Interface mode, this output chooses between attribute and common memory. In I/O Card Interface mode, this signal is active (low). In ATA mode this signal is always high.	64	104	1	TO	2 or 3	2 mA
A[25:0]	PCMCIA socket address outputs.	105, 103, 100, 98, 96, 94, 92, 89, 87, 97, 99, 90, 88, 101, 82, 77, 84, 86, 104, 106, 108, 110, 112, 114, 115, 117	180, 178, 175, 173, 171, 169, 167, 165, 163, 172, 174, 166, 164, 176, 157, 153, 159, 162, 179, 181, 183, 185, 187, 190, 191, 193	26	TO	2 or 3	2 mA
D[15:0] †	PCMCIA socket data I/O pins.	76, 74, 72, 70, 68, 124, 122, 120, 73, 71, 69, 67, 65, 123, 121, 119	152, 150, 148, 146, 144, 200, 198, 196, 149, 147, 145, 143, 141, 199, 197, 195	1	TO	2 or 3	2 mA
-OE	Output Enable: This output goes active (low) to indicate a memory read from the PCMCIA socket to the VG-PD6729.	80	155	1	TO	2 or 3	2 mA
-WE	Write Enable: This output goes active (low) to indicate a memory write from the VG-PD6729 to the PCMCIA socket.	93	168	1	TO	2 or 3	2 mA
-IORD	I/O Read: This output goes active (low) for I/O reads from the socket to the VG-PD6729.	83	158	1	TO	2 or 3	2 mA
-IOWR	I/O Write: This output goes active (low) for I/O writes from the VG-PD6729 to the socket.	85	160	1	TO	2 or 3	2 mA
WP/-IOIS16 †	Write Protect / I/O Is 16-Bit: In Memory Card Interface mode, this input is interpreted as the status of the write	125	201	1	I	-	-
-INPACK †	Input Acknowledge: The -INPACK function is not applicable in PCI bus environments. It is, however, advisable to connect this pin to the PC Card socket's - INPACK pin.	113	189	1	I-PU	2 or 3	-
NOTES:							
1. To differentiate the sockets, all socket-specific pins have either A_ or B_ prepended to the pin names indicated. For example, A_A[25:0] and B_A[25:0] are the independent address buses to the sockets.							
2. When a socket is configured as an ATA drive interface, socket interface pin functions change. See “ATA Mode Operation” on page 91.							



Table 2. Socket Interface Pins (Sheet 2 of 3)

Pin Name	Description	Pin Number		Qty.	I/O	Pwr.	Drive
		Socket A	Socket B				
RDY/-IREQ †	Ready / Interrupt Request: In Memory Card Interface mode, this input indicates to the VG-PD6729 that the card is either ready or busy. In I/O Card Interface mode, this input indicates a card interrupt request.	95	170	1	I-PU	2 or 3	-
-WAIT †	Wait: This input indicates a request by the card to the VG-PD6729 to halt the cycle in progress until this signal is deactivated.	111	186	1	I-PU	2 or 3	-
-CD[2:1]	Card Detect: These inputs indicate to the VG-PD6729 the presence of a card in the socket. They are internally pulled high to the voltage of the +5V power pin.	126, 66	202, 142	2	I-PU	1	-
-CE[2:1]	Card Enable: These outputs are driven low by the VG-PD6729 during card access cycles to control byte/word card access. -CE1 enables even-numbered address bytes, and -CE2 enables odd-numbered address bytes. When configured for 8-bit cards, only -CE1 is active and A0 is used to indicate access of odd- or even- numbered bytes.	79, 75	154, 151	2	TO	2 or 3	2 mA
RESET	Card Reset: This output is low for normal operation and goes high to reset the card. To prevent reset glitches to a card, this signal is high-impedance unless a card is seated in the socket, card power is applied, and the card's interface signals are enabled.	109	184	1	TO	2 or 3	2 mA
BVD2/-SPKR/ -LED †	Battery Voltage Detect 2 / Speaker / LED: In Memory Card Interface mode, this input serves as the BVD2 (battery warning status) input. In I/O Card Interface mode, this input can be configured as a card's - SPKR binary audio input. For ATA or non- ATA (SFF-68) disk-drive support, this input can also be configured as a drive-status LED input.	116	192	1	I-PU	2 or 3	-
BVD1/ -STSCHG/-RI †	Battery Voltage Detect 1 / Status Change / Ring Indicate: In Memory Card Interface mode, this input serves as the BVD1 (battery-dead status) input. In I/O Card Interface mode, this input is the - STSCHG input, which indicates to the VG-PD6729 that the card's internal status has changed. If bit 7 of the Interrupt and General Control register is set to a '1', this pin serves as the ring indicate input for wakeup-on-ring system power management support.	118	194	1	I-PU	2 or 3	-

NOTES:

1. To differentiate the sockets, all socket-specific pins have either A_ or B_ prepended to the pin names indicated. For example, A_A[25:0] and B_A[25:0] are the independent address buses to the sockets.
2. When a socket is configured as an ATA drive interface, socket interface pin functions change. See "ATA Mode Operation" on page 91.



PCI-to-PC Card (PCMCIA) Host Controller – VG-PD6729

Table 2. Socket Interface Pins (Sheet 3 of 3)

Pin Name	Description	Pin Number		Qty.	I/O	Pwr.	Drive
		Socket A	Socket B				
VS2	Voltage Sense 2: This pin is used in conjunction with VS1 to determine the operating voltage of the card. This pin is internally pulled high to the voltage of the +5V power pin. This pin should be connected to PCMCIA socket pin 57.	107	182	1	I	1	-
VS1	Voltage Sense 1: This pin is used in conjunction with VS2 to determine the operating voltage of the card. This pin is internally pulled high to the voltage of the +5V power pin. This pin should be connected to PCMCIA socket pin 43.	81	156	1	I	1	-
SOCKET_VCC	This pin can be connected to either a 3.3- or 5-volt power supply. The socket interface outputs (listed in this table, Table 2) will operate at the voltage applied to these pins, independent of the voltage applied to other VG-PD6729 pin groups. Connect these pins to the V _{CC} supply of the socket (pins 17 and 51 of the respective PCMCIA socket).	78, 102	161, 188	2	PW	-	-
NOTES:							
1. To differentiate the sockets, all socket-specific pins have either A_ or B_ prepended to the pin names indicated. For example, A_A[25:0] and B_A[25:0] are the independent address buses to the sockets.							
2. When a socket is configured as an ATA drive interface, socket interface pin functions change. See “ATA Mode Operation” on page 91.							

Table 3. Power Control and General Interface Pins (Sheet 1 of 2)

Pin Name	Description	Pin Number		Qty.	I/O	Pwr.	Drive
		Socket A	Socket B				
VPP_VCC	This active-high output controls the socket V _{CC} supply to the socket's V _{PP1} and V _{PP2} pins. The active-high level of this output is mutually exclusive with that of VPP_PGM.	128	135	1	O	1	12 mA
VPP_PGM	This active-high output controls the programming voltage supply to the socket's V _{PP1} and V _{PP2} pins. The active- high level of this output is mutually exclusive with that of VPP_VCC.	127	134	1	O	1	12 mA
-VCC_3	This active-low output controls the 3.3-volt supply to the socket's V _{CC} pins. The active-low level of this output is mutually	129	136	1	O	1	12 mA



Table 3. Power Control and General Interface Pins (Sheet 2 of 2)

Pin Name	Description	Pin Number		Qty.	I/O	Pwr.	Drive
		Socket A	Socket B				
-VCC_5	This active-low output controls the 5-volt supply to the socket's V _{CC} pins. The active-low level of this output is mutually exclusive with that of -VCC_3.	130	138	1	O	1	12 mA
SPKR_OUT*	Speaker Output: This output can be used as a digital output to a speaker to allow a system to support PCMCIA card fax/ modem/voice and audio sound output. This output is enabled by setting the socket's Misc Control 1 register bit 4 to a '1' (for the socket whose speaker signal is to be directed from BVD2/-SPKR/-LED to this pin).	132		1	TO-PU	4	12 mA
LED_OUT*	LED Output: This output can be used as an LED driver to indicate disk activity when a socket's BVD2/-SPKR/-LED pin has been programmed for LED support. The Extension Control 1 register bit 2 must be set to a '1' to enable this output as an LED indicator for the VG-PD6729, and a socket's ATA Control register bit 1 must be set to a '1' to allow the level of the particular socket's BVD2/-SPKR/-LED pin to pass through to the LED_OUT* pin, or a socket's Extension Control 1 bit 1 must be set to a '1' to allow card-cycle activity to cause the LED_OUT* pin to go active low.	133		1	O	4	12 mA

Table 4. Power, Ground, and No-Connect Pins

Pin Name	Description	Pin Number	Qty.	I/O	Pwr.	Drive
+5V	This pin is connected to the system's 5-volt power supply, unless 5 volts is not available. In systems where 5 volts is not available, this pin is connected to the system's 3.3-volt supply.	131	4	PW	-	-
CORE_VDD	This pin provides power to the core circuitry of the VG-PD6729. It can be connected to either a 3.3- or 5- volt power supply, independent of the operating voltage of other interfaces. For power conservation on a system with a 3.3-volt supply available, this pin should be connected to the 3.3- volt supply even if there is no intention of operating other interfaces on the device at less than 5 volts.	139	1	PW	-	-
CORE_GND	All VG-PD6729 ground lines should be connected to system ground.	26	1	PW	-	-
RING_GND	All VG-PD6729 ground lines should be connected to system ground.	14, 28, 44, 56, 91, 137, 177	7	PW	-	-
NC	can be left unconnected. Pin 2 is an output, and pins 3 and 208 are inputs. There is no need to tie input pins 3 and 208 to V _{DD} or ground.	2, 3, 208	3	-	-	-



PCI-to-PC Card (PCMCIA) Host Controller – VG-PD6729

Table 5. Pin Usage Summary

Pin Group	Pin Quantity
PCI bus interface pins	63
Socket interface pins	122
Power control and general interface pins	10
Power, ground, and no-connect pins	13
Total:	208



3.0 Introduction to the VG-PD6729

3.1 System Architecture

This section describes PCMCIA basics, windowing, socket power management features, interrupts, device power management, write FIFO usage, bus sizing, programmable PCMCIA timing, and ATA mode operation.

3.1.1 PCMCIA Basics

PCMCIA is an abbreviation for Personal Computer Memory Card International Association. PCMCIA 2.1 is a standard for using memory and I/O devices as insertable, exchangeable peripherals for PCs (personal computers) and handheld computers.

Note: The VG-PD6729 is backward-compatible with PCMCIA standards 1.0, 2.0, and 2.01. The VG-PD6729 is also compatible with JEIDA 4.1 and its earlier standards corresponding with the PCMCIA standards above.

For simpler end-user and vendor implementation of the standard, systems employing PCMCIA 2.1 should also be backward-compatible with industry-standard PC addressing.

For PCMCIA memory-type cards, the memory information must be mapped into the system memory address space. This is accomplished with a ‘windowing’ technique that is similar to expanded memory schemes already used in PC systems (for example, LIM 4.0 memory manager).

PCMCIA cards can have *attribute* and *common* memory. Attribute memory is used to indicate to host software the capabilities of the PCMCIA card, and it allows host software to change the configuration of the card. Common memory can be used by host software for any purpose (such as flash file system, system memory, and floppy emulation).

PCMCIA I/O-type cards, such as modem network cards, should also be directly addressable, as if the cards were I/O devices plugged into the PCI bus. For example, it would be highly desirable to have a PCMCIA modem accessible to standard communications software as if it were at a COM port. For COM1, this would require that the modem be accessed at system I/O address 3F8h–3FFh. The method of mapping a PCMCIA I/O address into anticipated areas of PCI I/O space is done similarly to memory windowing.

PCMCIA I/O-type cards usually have interrupts that need to be serviced by host software. For the example of a modem card accessed as if at COM1, software would expect the modem to generate interrupts on the IRQ4 line. To be sure all interrupts are routed as expected, the VG-PD6729 can steer the interrupt from the PCMCIA card to one of the four PCI-bus-defined interrupts or to one of several standard PC interrupts (see “Interrupts” on page 27 and “Interrupt and General Control” on page 52).

3.1.2 VG-PD6729 Windowing

For full compatibility with existing software, and to ensure compatibility with future memory cards and software, the VG-PD6729 provides five programmable memory windows per socket and two programmable I/O windows per socket. These windows can be used by an inserted PCMCIA card to access PCI memory and I/O space.



PCI-to-PC Card (PCMCIA) Host Controller – VG-PD6729

Having five memory windows per socket allows a memory-type card to be accessed through four memory windows programmed for common memory access, (allowing PC-type expanded-memory-style management), leaving the fifth memory window available to be programmed to access the card's attribute memory without disrupting the common memory in use.

Each memory window has several programming options, including:

Memory Window Option	Descriptions
Enable	Each of the five memory windows can be individually enabled. Disabled windows are not responded to.
Start Address	This is the start address of the memory window within the selected 16-Mbyte page of PCI memory. The start address can be programmed to reside on any 4-Kbyte boundary within the programmed page of PCI memory.
End Address	This is the end address of the memory window within the selected 16-Mbyte page of PCI memory. The end address can be programmed to reside on any 4-Kbyte boundary within the programmed page of PCI memory. Only memory accesses between the start and end address are responded to.
Offset Address	The offset address is added to the PCI address to determine the address for accessing the PCMCIA card. This allows the addresses in the PCMCIA address space to be different from the PCI address space.
Upper Address	The upper memory address specifies a 16-Mbyte page of PCI memory.
Timing	The timing of accesses (Setup/Command/Recovery) can be set by either of two timing register sets: Timer Set 0 or Timer Set 1.
Register Access Setting	The -REG pin can be enabled on a per-window basis so that any of the windows can be used for accessing attribute memory.
Write Protect	If the window is programmed to be write-protected, then writes to the memory window are ignored (reads are still performed normally).

Each I/O window also has several programming options, including:

I/O Window Option	Descriptions
Enable	Each of the two I/O windows can be individually enabled.
Start Address	The start address of the window is programmable on single-byte boundaries from 0 to 64 Kbytes.
End Address	The end address of the window is also programmable on single-byte boundaries from 0 to 64 Kbytes.
Offset Address	The offset address is added to the PCI address to determine the address for accessing the PCMCIA card
Auto Size	The size of accesses can be set automatically, based on the PCMCIA -IOIS16 signal
Data Size	The size of accesses can be set manually to either 8 or 16 bits, overriding the Auto Size option.
Timing	The timing of accesses (Setup/Command/Recovery) can be set by either of two timing register sets: Timer Set 0 or Timer Set 1.



Caution: The windows of the VG-PD6729 should never be allowed to overlap with each other or the other devices in the system. This would cause signal collisions, resulting in erratic behavior.

Figure 4. Memory Window Organization

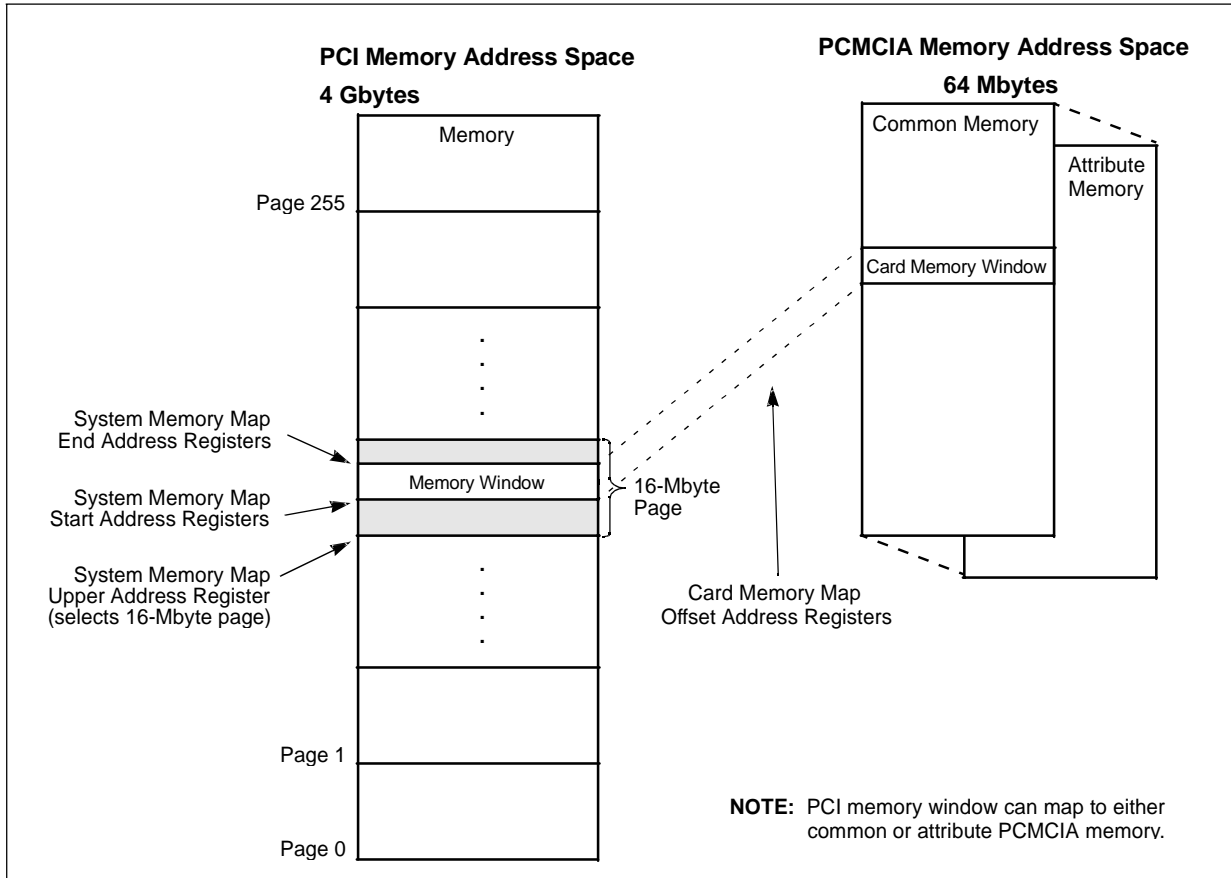
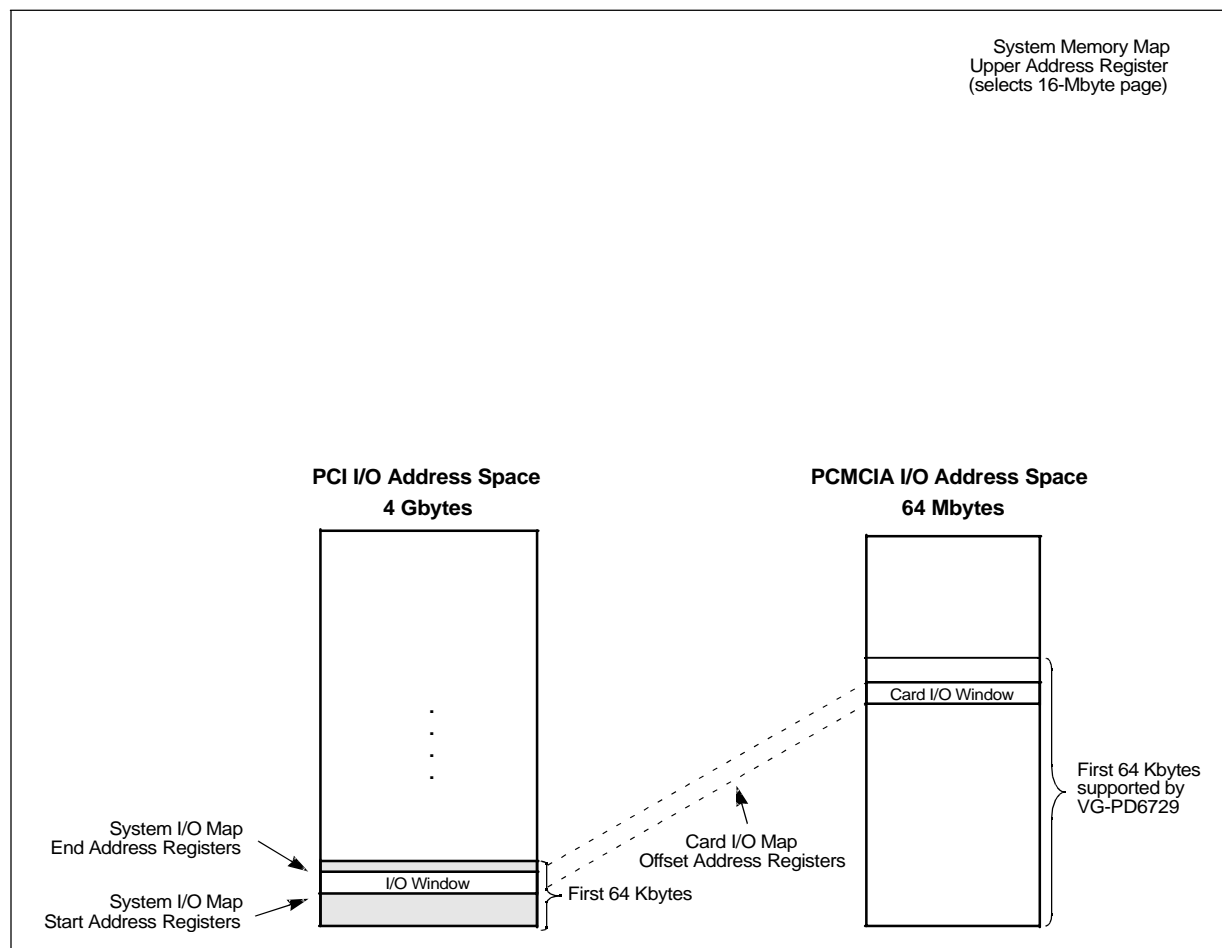

Figure 5. I/O Window Organization



3.1.3 Zoomed Video Port

The VG-PD6729 supports the implementation of the ZV (Zoomed Video) Port at the PC Card interface. The ZV Port provides a direct connection between a PC Card and VGA controller and an audio DAC. It allows the PC Card to directly write video data to an input port of a graphics controller and audio data to a digital-to-analog converter.

The VG-PD6729 supports the ZV Port in the “bypass” mode during which the signals are directly routed from the PC Card bus to the video port of the VGA controller. Rerouting is accomplished by tristating address lines A[25:4] from the VG-PD6729. The VG-PD6729 enters the ZV Port mode when the Multimedia Enable bit (bit 0 of the **Misc. Control 1** register at index 16h) and the Multimedia Arm bit (bit 7 of the **Misc. Control 3** register at extended index 25h) are set to a ‘1’.

Figure 6 shows an example of the ZV Port implementation using the VG-PD6729. For more details, refer to the application note *Zoomed Video (ZV) Port Implementation (AN-PD10)*.

Figure 6. A Typical ZV Port Implementation

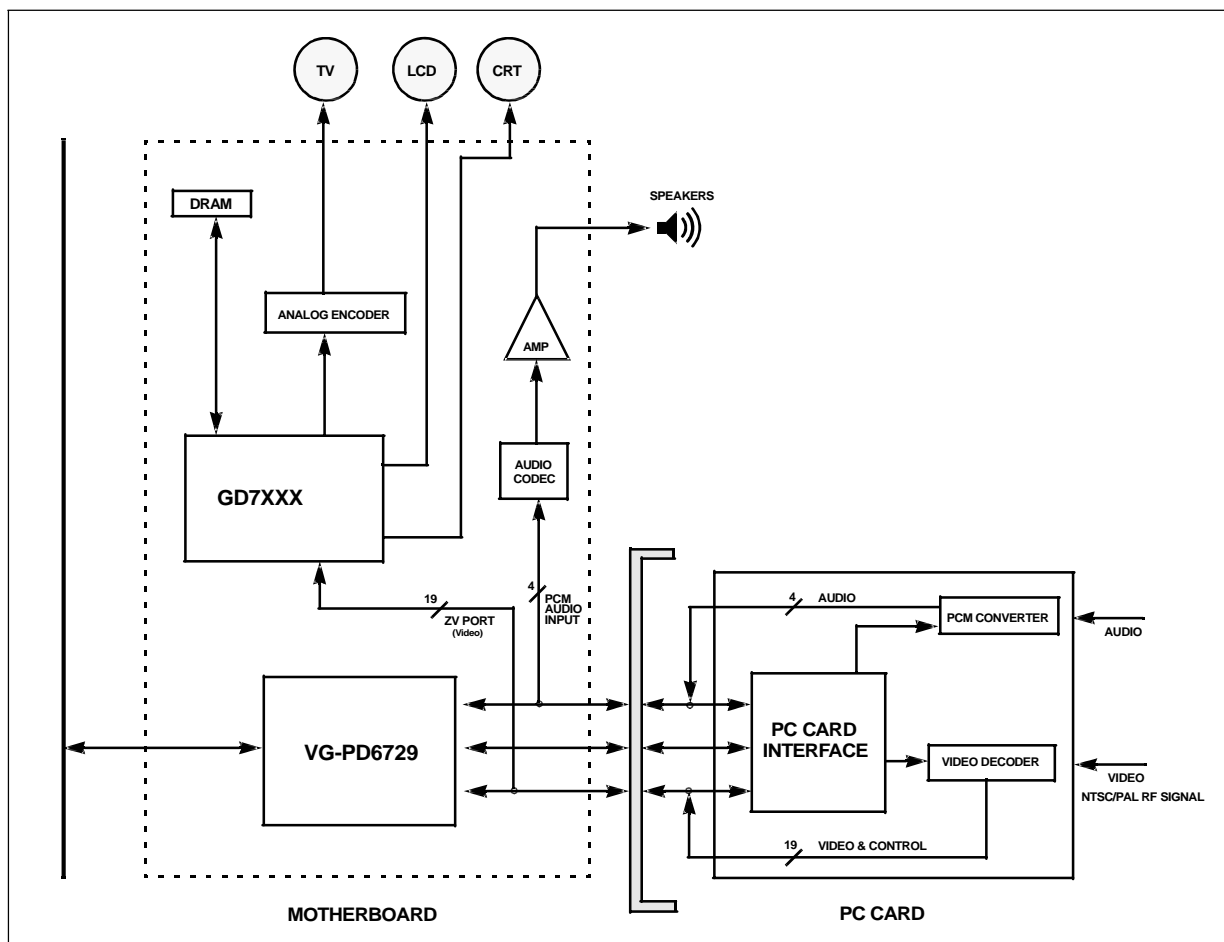

3.1.4 Interrupts

In a PC-compatible system with a PCI bus, there usually are two types of interrupts in use:

- Four PCI-defined, active-low, open-drain, shared interrupt lines INTA# through INTD#
- A number of ISA-architecture-defined, active-high, totem-pole IRQ output interrupts

The VG-PD6729 provides ten interrupt pins that are individually programmable to work as either PCI-type 'INT#' open-drain interrupts or ISA-type 'IRQ' totem-pole output interrupts. Bits 3 and 4 of the **Extension Control 1** register select PCI-bus or ISA-architecture-compatible interrupt programming.

The VG-PD6729 interrupt pins are labeled with names suggesting their mapping in a PCI-bus-based, ISA-architecture-compatible system, though there are no hard requirements specifying the exact mapping. Typically, all ten interrupt pins should be connected to system interrupt signals to allow maximum flexibility in programming interrupt routing from the VG-PD6729.



Figure 7. A Common Mapping of VG-PD6729 Interrupt Pins to System Interrupt Signals

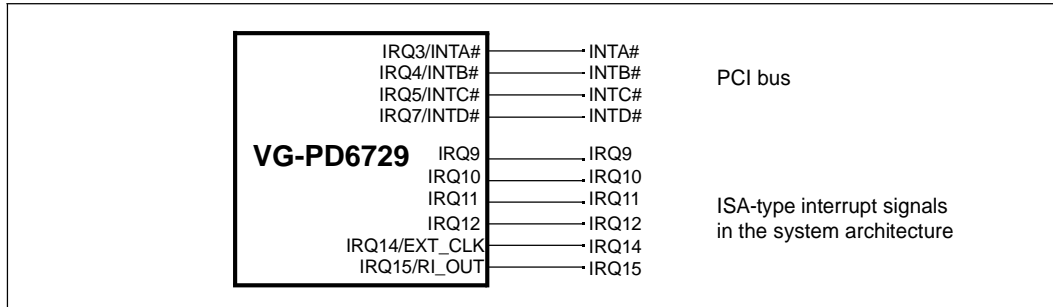

3.1.4.1 Classes of Interrupts

The VG-PD6729 supports two classes of interrupts:

- Socket or card interrupts initiated by a PCMCIA I/O-type card activating its RDY/-IREQ signal
- Management interrupts triggered by changes in PCMCIA card status

There are four card-status-change conditions that can be programmed to cause management interrupts:

- Card insertion or removal
- Battery warning indicator (BVD2) change on a memory-type card
- Battery dead indicator (BVD1) or I/O-type card status change (STSCHG)
- Ready (RDY) status change on a PCMCIA memory-type card

Either class of interrupts can be routed to any of the ten interrupt pins on the VG-

3.1.4.2 Connection of Interrupt Pins Programmed as PCI-Bus INT# Signals

Pins programmed as INT#-type interrupts can be connected to the correspondingly named signals on the PCI bus.

If the management interrupt is being routed to a pin connected to a PCI-bus INT# signal, bit 4 of the **Extension Control 1** register should be set to a '1'. If the card interrupt is being routed to a pin connected to a PCI-bus INT# signal, bit 3 of the **Extension Control 1** register should be set to a '1'.

Although four of the ten VG-PD6729 interrupt pins are labeled as INTA# through INTD#, any of the ten interrupt pins can be used as PCI-type INT# signals.

3.1.4.3 Connection of Interrupt Pins Programmed as ISA-Architecture-Compatible IRQ Signals

IRQ-type interrupts in PC-compatible systems are not generally shared by hardware. Therefore, each device in the system using IRQ-type interrupts must have a unique interrupt line. Additionally, many software applications assume that certain I/O devices use specific IRQ signals. To allow



PCMCIA cards with differing I/O functionalities to be connected to appropriate non-conflicting IRQ locations, the VG-PD6729 can steer the interrupt signal from a PCMCIA card to any one of the ten different hardware interrupt lines.

For some I/O-type cards, software is written so that IRQ interrupts can be shared. The VG-PD6729 contains unique logic that allows IRQ-type interrupts to be shared under software control. This is accomplished by programming the VG-PD6729 to alternately pulse and then three-state the desired interrupt pin, which has been programmed as an IRQ-type output. This unique IRQ interrupt sharing technique can be controlled through software so that systems incapable of IRQ sharing have no loss of functionality.

3.1.4.4 Alternate Functions of Interrupt Pins

The VG-PD6729 has two dual-function interrupt pins: IRQ14/EXT_CLK and IRQ15/RI_OUT*. In their default modes, these pins indicate interrupt requests IRQ14 and IRQ15.

IRQ14/EXT_CLK can alternately be configured as an external clock input (EXT_CLK). When configured in External Clock mode by programming **Misc Control 2** register bit 0 to a '1', IRQ14/EXT_CLK acts as a clock input, bringing in an external clock that drives the VG-PD6729 circuitry whenever the PCI bus is inactive.

Similarly, IRQ15/RI_OUT* can alternately be configured to function as a ring indicator output (RI_OUT*) to an 80360-type chip set's -RI input. When configured in Ring Indicate mode by programming **Misc Control 2** register bit 7 to a '1', outputs from a PCMCIA I/O card's -STSCHG pin are passed through to the IRQ15/RI_OUT* pin of the VG-PD6729.

Note: **Interrupt and General Control** register bits 5 and 7 must be set to '1's for a socket interface to accept an -RI input.

3.1.5 VG-PD6729 Power Management

To provide the longest possible battery life, the VG-PD6729 provides many power management features, including Low-power Dynamic mode, Suspend mode, and control of PCMCIA socket power.

Low-power Dynamic mode is transparent to the PCI bus. After reset, the VG-PD6729 is configured for Low-power Dynamic mode. This mode can be turned off by setting **Misc Control 2** register, bit 1 to a '0'. When in Low-power Dynamic mode, periods of inactivity (no activity on the PCMCIA bus and system accesses to chip registers or inserted cards are no longer being performed) cause the VG-PD6729 to enter a low-power state where the clock is turned off to most of the chip and the PCMCIA address and data lines are set to a static value. V_{CC} and V_{PP} power to the card is left unchanged. When there is activity present on the PCMCIA bus, or the system accesses VG-PD6729 registers, or PCMCIA cards are inserted or removed from the socket, the VG-PD6729 enters its active state, services the transaction, and then returns to its low-power state.

A Suspend mode can also be programmed. The VG-PD6729 Suspend mode is the chip's lowest power mode. The VG-PD6729 is put into Suspend mode by setting the **Misc Control 2** register, bit 2 to a '1'. In Suspend mode, all the internal clocks are turned off, and only read/write access to the PCI- Configuration registers, read/write access of the **Index** register, and write access to the **Misc Control 2** register is supported. All accesses to the PCMCIA cards are ignored when in Suspend mode. V_{CC} and V_{PP} power to the card is left unchanged (the system power management software is responsible for turning off power to the socket and entering Suspend mode). Interrupts are passed through to the processor when in Suspend mode. To exit Suspend mode, the **Misc Control 2** register bit 2 must be reset to a '0'.



PCI-to-PC Card (PCMCIA) Host Controller – VG-PD6729

The VG-PD6729 power can be further managed by controlling socket power as outlined in “[Socket Power Management Features](#)” on page 30. Socket power can be turned on and off through software or automatically when cards are inserted or removed. The VG-PD6729 provides six pins per socket for controlling external logic to switch V_{CC} and V_{PP} voltages on and off and for sensing a card’s operating voltage range. Cards can be turned off when they are not in use.

Table 6. VG-PD6729 Power-Management

Mode Name	RST# Level	Misc Control 2 Register		Functionality	Typical Power Consumption (PCI_VCC = 5.0V, PCI_K = 33 MHz, CORE_VDD = 3.3V, +5V = 5.0V)
		Suspend Mode (Bit 2)	Low-Power Dynamic Mode (Bit 1)		
Low-power Dynamic (default)	High	0	1	Full functionality	6.4 mW
Normal	High	0	0	Full functionality	14 mW
Suspend (software-controlled)	High	1	–	8-bit access to Misc Control 2 register. No other register access. No card in socket(s).	6.4 mW
Reset	Low	–	–	No register access. No card in socket(s). System bus signals disabled.	21 mW

3.1.6 Socket Power Management Features

Card Removal

When a card is removed from a socket, the VG-PD6729 by default automatically disables the V_{CC} and V_{PP} supplies to the socket. If **Extension Control 1** register bit 1 is a ‘1’, **Power Control** register bit 4 is prevented from being automatically cleared when a card is removed. The VG-PD6729 can also be configured to have management interrupts notify software of card removal.

Card Insertion

At reset, and whenever there is no card in a socket, power to the socket is off. When a card is detected (card detect input pins, -CD1 and -CD2, to the VG-PD6729 become asserted low), two independent actions can be programmed to occur.

If the VG-PD6729 has been set for automatic power-on (**Power Control** register bits 4 and 5 are both ‘1’s), the VG-PD6729 automatically enables the socket V_{CC} supply (and, if so programmed, V_{PP} supply).

If the VG-PD6729 has been programmed to cause management interrupts for card-detection events, assertion of -CD1 and -CD2 to the VG-PD6729 causes a management interrupt to be generated to inform system software that a card was inserted. In the case of manual power detection (**Power Control** register bits 5 is a ‘0’), system software can then determine the card’s operating voltage range and then power-up the socket and initialize the card, or if programmed for automatic power-on (**Power Control** register bits 5 is a ‘1’ and **Extension Control 1** register bit 1 is a ‘1’), simply initialize the card.



3.1.7 Write FIFO

To increase performance when writing to PCMCIA cards, two, independent, four-word-deep write FIFOs are used. Writes to PCMCIA cards will complete without holding off the PCI bus until the FIFO is full.

Note: Register states should only be changed when the write FIFO is empty.

3.1.8 Bus Sizing

The VG-PD6729 operates in 32-bit mode. All PCI transactions are 32-bit, even when supporting 8-bit- only or 16-bit PCMCIA cards.

3.1.9 Programmable PCMCIA Timing

The Setup, Command, and Recovery time for the PCMCIA bus is programmable (see “[Timing Registers](#)” on page 87). The VG-PD6729 can be programmed to match the timing requirements of any PCMCIA card. There are two sets of timing registers, Timer Set 0 and Timer Set 1, that can be selected on a per-window basis for both I/O and memory windows.

By setting one of the timing sets for a Recovery time equal to flash memory programming time and utilizing the write FIFO, algorithms can be created to relieve system software of the necessity of doing timing loops, and thus allow for flash programming in the background.

3.1.10 ATA Mode Operation

The VG-PD6729 supports direct connection to AT-attached-interface hard drives. ATA drives use an interface very similar to the IDE interface found on many popular portable computers. See “[ATAMode Operation](#)” on page 91 for more information.

3.1.11 VS1 and VS2

The pins VS1 and VS2 can be used to determine the voltage capabilities of an inserted card. The status of these pins, for both sockets, are indicated by bits 3:0 of the **External Data** register at extended index 0Ah of index 6Fh (this is true even though registers 40h–7Fh are generally for Socket B only).

3.2 Host Access to Registers

The VG-PD6729 registers are accessed through an 8-bit indexing mechanism. An index register scheme allows a large number of internal registers to be accessed by the CPU using only two I/O addresses.

The **Index** register (see “[Operation Registers](#)” on page 43) is used to specify which of the internal registers the CPU will access next. The value in the **Index** register is called the Register Index and is the number that specifies a unique internal register. The **Data** register is used by the CPU to read and write the internal register specified by the **Index** register.

Figure 8. Indexed 8-Bit Register Structure

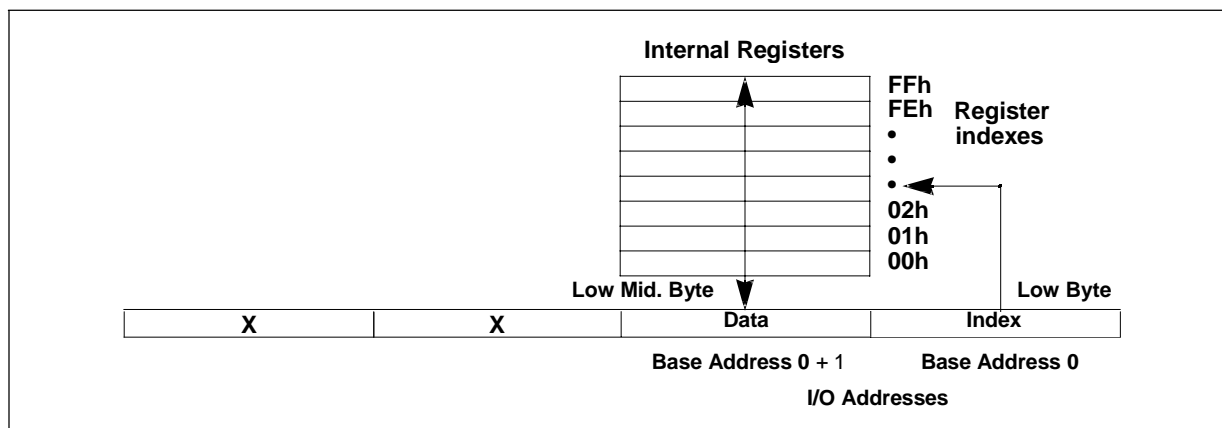
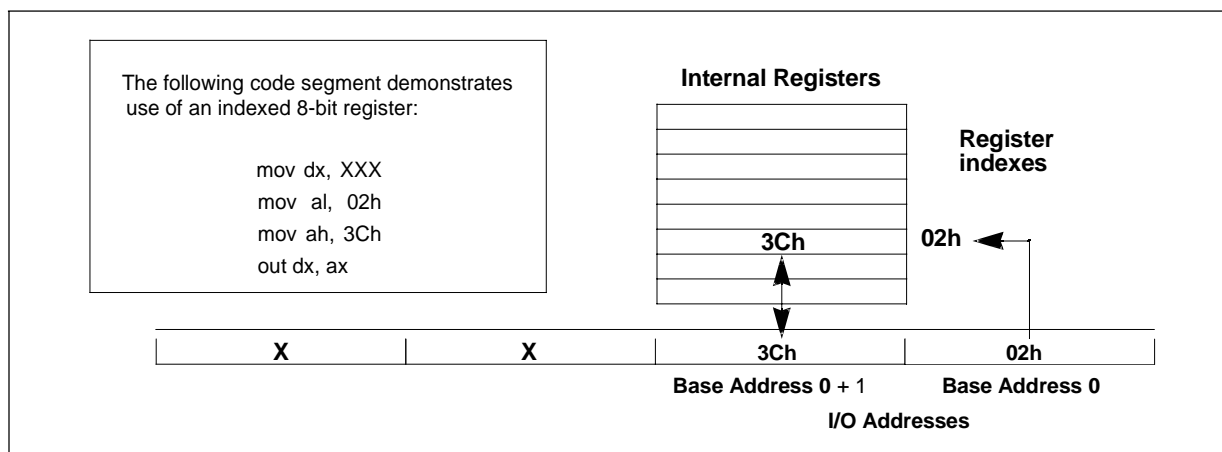

Figure 9. Indexed 8-Bit Register Example



The VG-PD6729 has Extension registers that add to the functionality of the 82365SL-compatible register set. Within the Extension registers is an **Extended Index** register and **Extended Data** register that provide access to more registers. The registers accessed through **Extended Index** and **Extended Data** are thus double indexed. The example below shows how to access the **Extension Control 1** register, one of the double-indexed registers.

```

;Write to Extension Control 1 register example

;Constants section
    Extended_Index      EQU 2Eh
    Index_Reg           EQU 2Fh
    Ext_Cntrl_1        EQU 03h
    Base_IO_Address

;Code section
    mov    dx, Base_IO_Address
    mov    al, Extended_Index
    mov    ah, Ext_Cntrl_1
    out    dx, ax
    mov    al, Index_Reg
    mov    ah, user data ;Desired data to be

```



```
out    dx, ax          ;written to
                          ;extended index 3

;Read from Extension Control 1 register example

;Code section
mov    dx, Base_IO_Address
mov    al, Extended_Index
mov    ah, Ext_Cntrl_1
out    dx, ax
mov    al, Index_Reg
out    dx, al
inc    dx              ;al has extended
in     al, dx          ;index 3 data
```

3.3 Power-On Setup

Following RST#-activated reset, the VG-PD6729 must be configured by host initialization or BIOS software. The application of the RST# signal on power-up causes initialization of all the VG-PD6729 register bits and fields to their reset values.



4.0 Register Description Conventions

Register Headings

The description of each register starts with a header containing the following information:

Header Field	Description
Register Name	This indicates the register name.
Offset	This is added to the base address to generate the total effective address. This field is for PCI-Configuration registers only.
Register Per	This indicates whether the register affects both sockets, marked chip, or an individual socket, marked socket. If socket is indicated, there are two registers being described, each with a separate Index value (one for each socket, A and B). ¹
Index ¹	This is the Index value through which an internal register in an indexed register set is accessed.
Register Compatibility Type	This indicates whether the register is 82365SL-compatible, marked 365 or a register extension, marked ext.
NOTE: 1. When the register is socket-specific, the Index value given in the register heading is for Socket A only. For the Socket B register, add 40h to the Index value of the Socket A register.	

Special Function Bits

Following is a description of bits with special functions:

Bit Type	Description
Reserved	These bits are Reserved and should not be changed.
Compatibility Bit	These bits have no function on the VG-PD6729 but are included for compatibility with the 82365SL register set.
0 or 1	These read-only bits are forced to either a '0' or '1' at reset and cannot be changed
Scratchpad Bit	These read/write bits are available for use as bits of memory.



Bit Naming Conventions

Keyword	Description
Enable	Indicates that the function described in the rest of the bit name is active when the bit is a '1'.
Disable	Indicates that the function described in the rest of the bit name is active when the bit is a '0'.
Mode	Indicates that the function of the bit alters the interpretation of the values in other registers
Input	Indicates a bit or field that is read from a pin
Output	Indicates a bit or field that is driven to a pin.
Select	Indicates that the bit or field selects between multiple alternatives. Fields that contain Select in their names have an indirect mapping between the value of the field and the effect.
Status	Indicates one of two types of bits: either Read-only bits used by the VG-PD6729 to report information to the system or bits set by the VG-PD6729 in response to an event, and can also be cleared by the system. The system cannot directly cause a Status bit to become a '1'.
Value	Indicates that the bit or field value is used as a number.

Bit Descriptions

When used to describe an action taken by the host system, the phrase “the system *sets* a bit” is the same as stating “the system writes the appropriate register with a ‘1’ (one) in the bit”.

Similarly, the phrase “the system *resets* a bit” or “the system *clears* a bit” is the same as stating “the system writes the appropriate register with a ‘0’ (zero) in the bit”.



5.0 PCI-Configuration Registers

These registers occupy offsets 00–3Fh. They control basic PCI bus functionality. PCMCIA Operation registers are accessed through the **Base Address 0** register. The registers in this section apply to the entire chip: they are not specific to either socket.

Caution: If bits indicated as read only (R:) are to be written to, they should be written to a ‘0’.

5.1 Vendor ID and Device ID

Configuration Register Name: Vendor ID and Device ID								Register Per: chip
Offset: 00h								
3 Device ID (high)	Bit 31	Bit 30	Bit 29	Bit 28	Bit 27	Bit 26	Bit 25	Bit 24
	Device ID (high) R:00010001							
2 Device ID (low)	Bit 23	Bit 22	Bit 21	Bit 20	Bit 19	Bit 18	Bit 17	Bit 16
	Device ID (low) R:00000000							
1 Vendor ID (high)	Bit 15	Bit 14	Bit 13	Bit 12	Bit 11	Bit 10	Bit 9	Bit 8
	Vendor ID (high) R:00010000							
0 Vendor ID (low)	Bit 7	Bit 6	Bit 5	Bit 4	Bit 3	Bit 2	Bit 1	Bit 0
	Vendor ID (low) R:00010011							

Bits 15-0: Vendor ID

This read-only field is the vendor identification assigned to Cirrus Logic¹ by the PCI Special Interest Group. This field always reads back 1013h.

Bits 31-16: Device ID

This read-only field is the device identification. This field always reads back 1100h for the VG-PD6729. Revision number identification for the VG-PD6729 part itself is indicated by the Mask Revision byte at extended index 39h.

1. Now supported by Amplus Inc..



5.2 Command and Status

Configuration Register Name: Command and Status								Register Per: chip
Offset: 04h								
3 Status (high)	Bit 31	Bit 30	Bit 29	Bit 28	Bit 27	Bit 26	Bit 25	Bit 24
	Address/ Data Parity Error Detected RW:0	System Error (SERR#) Generated RW:0	Reserved R:XXX			DEVSEL# Timing R:10		Master Data Parity Error Reported R:0
2 Status (low)	Bit 23	Bit 22	Bit 21	Bit 20	Bit 19	Bit 18	Bit 17	Bit 16
	Reserved R:XXXXXXXX							
1 Command (high)	Bit 15	Bit 14	Bit 13	Bit 12	Bit 11	Bit 10	Bit 9	Bit 8
	Reserved R:XXXXXXXX							System Error (SERR#) Enable RW:0
0 Command (low)	Bit 7	Bit 6	Bit 5	Bit 4	Bit 3	Bit 2	Bit 1	Bit 0
	Wait Cycle Enable R:1	Parity Error Check/ Report Enable RW:0	Reserved R:XXXX			PCI Memory Space Enable RW:0	PCI I/O Space Enable RW:0	

Bit 0: PCI I/O Space Enable

0	The I/O space for the VG-PD6729 is disabled. Any reads or writes to the I/O space will be ignored. This applies to both the I/O registers of the VG-PD6729 itself, as well as any I/O windows that might have been enabled to the PCMCIA sockets.
1	The I/O space for the VG-PD6729 is enabled and will respond to reads and writes to the I/O address range defined in Base Address 0 register as well as any I/O window addresses.

Bit 1: PCI Memory Space Enable

This bit must be set or the VG-PD6729 will not respond to memory

0	The memory space for the VG-PD6729 is disabled. Any reads or writes to the VG-PD6729 memory space will be ignored.
1	The memory space for the VG-PD6729 is enabled, allowing memory window access.



Bit 6: Parity Error Check/Report Enable

This bit enables all parity-reporting-related circuitry, except for bit 31 of this register.

0	Parity checking and reporting in the VG-PD6729 disabled.
1	Parity checking and reporting in the VG-PD6729 is enabled.

Bit 7: Wait Cycle Enable

This bit always reads a '1', indicating that the VG-PD6729 employs address

Bit 8: System Error (SERR#) Enable

This bit enables the VG-PD6729's reporting of system errors by assertion of the SERR# pin when address parity errors occur. Bit 6 must also be set to a '1' to allow detecting of conditions that allow SERR# activation. See also description of bit 30.

0	Activation of SERR# on address parity error is disabled.
1	SERR# is activated whenever an address parity error is internally detected (slave mode).

Bit 24: Master Data Parity Error Reported

This bit is Reserved and will always read a '0'.

Bits 26-25: DEVSEL# Timing

This field always reads back '10', identifying the VG-PD6729 as a slow-speed

Bits 29-27: Reserved

These bits are reserved for future use. On writes to this register, these bits should be written as '0'. The value of these bits should be considered as indeterminate on reads of this register.

Bit 30: System Error (SERR#) Generated

This bit is set whenever the VG-PD6729 asserts SERR# because of internal detection of a PCI address parity error. Bit 8 of this register must be set before system errors can be reported, and bit 6 must be set to allow address parity errors to be detected. The VG-PD6729 only asserts SERR# if address parity errors occur. No other chip or system actions will cause SERR# to be driven active.

0	SERR# was not asserted by this device.
1	SERR# was asserted by this device, indicating a PCI address parity error.

Bit 31: Address/Data Parity Error Detected

This bit indicates whether a parity error was detected, independently of whether bit 6 of this register is a '1'.



0	No data parity errors detected.
1	Address or data parity error detected.

5.3 Revision ID and Class Code

Configuration Register Name: Revision ID and Class Code								Register Per: chip
Offset: 08h								
3 Class Code (high)	Bit 31	Bit 30	Bit 29	Bit 28	Bit 27	Bit 26	Bit 25	Bit 24
	Class Code (high)							
	R:00000110							
2 Class Code (mid.)	Bit 23	Bit 22	Bit 21	Bit 20	Bit 19	Bit 18	Bit 17	Bit 16
	Class Code (mid.)							
R:00000101								
1 Class Code (low)	Bit 15	Bit 14	Bit 13	Bit 12	Bit 11	Bit 10	Bit 9	Bit 8
	Class Code (low)							
R:00000000								
0 Revision ID	Bit 7	Bit 6	Bit 5	Bit 4	Bit 3	Bit 2	Bit 1	Bit 0
	Revision ID							
R:nnnnnnnn ¹								
NOTE:								
1. This read-only value depends on the revision level of the VG-PD6729. For VG-PD6729 Revision E or later, these bits correspond to the value of the Mask Revision Byte register at extended index 34h.								

Bits 7-0: Revision ID

This read-only field identifies the revision level of the VG-PD6729

Bits 31-8: Class Code

This field always reads back 060500h, identifying the VG-PD6729 as a PCI-to-PCMCIA bridge device.



5.4 Cache Line Size, Latency Timer, Header Type, and BIST

Configuration Register Name: Cache Line Size, Latency Timer, Header Type, and BIST								Register Per: chip
Offset: 0Ch								
	Bit 31	Bit 30	Bit 29	Bit 28	Bit 27	Bit 26	Bit 25	Bit 24
3 BIST	Reserved							
	R:XXXXXXXX							
2 Header Type	Bit 23	Bit 22	Bit 21	Bit 20	Bit 19	Bit 18	Bit 17	Bit 16
	Header Type							
R:00000000								
1 Latency Timer	Bit 15	Bit 14	Bit 13	Bit 12	Bit 11	Bit 10	Bit 9	Bit 8
	Reserved							
R:XXXXXXXX								
0 Cache Line Size	Bit 7	Bit 6	Bit 5	Bit 4	Bit 3	Bit 2	Bit 1	Bit 0
	Reserved							
R:XXXXXXXX								

Bits 31:24 BIST Register

These bits will always read back 00h. The VG-PD6729 uses proprietary manufacturing test methods instead of BIST test features.

Bits 23:16 Header Type Register

These bits will always read back 00h and specifies that the VG-PD6729 uses the standard type 00 configuration space header register layout for configuration bytes 10h through 3Fh.

Bits 31:24 Latency Timer Register

Since the VG-PD6729 does not use bus mastering, this bit field is always 00h.

Bits 7:0 BIST Register

These bits will always read back 00h, indicating that the VG-PD6729 does not participate in PCI- defined caching algorithms.



5.5 Base Address 0

Configuration Register Name: Base Address 0								Register Per: chip
Offset: 10h								
Byte3	Bit 31	Bit 30	Bit 29	Bit 28	Bit 27	Bit 26	Bit 25	Bit 24
	I/O Base Address (high)							
RW:00000000								
Byte 2	Bit 23	Bit 22	Bit 21	Bit 20	Bit 19	Bit 18	Bit 17	Bit 16
	I/O Base Address (high mid.)							
RW:00000000								
Byte1	Bit 15	Bit 14	Bit 13	Bit 12	Bit 11	Bit 10	Bit 9	Bit 8
	I/O Base Address (low mid.)							
RW:00000000								
Byte 0	Bit 7	Bit 6	Bit 5	Bit 4	Bit 3	Bit 2	Bit 1	Bit 0
	I/O Base Address (low)							I/O Space Indicator
RW:000000							R:0	R:1

This is the PCI I/O address space base address for the Operation registers.

Bit 0: I/O Space Indicator

This bit always reads back a '1', indicating that this base address register defines a PCI I/O space.

Bit 1: Reserved

This bit always reads back a '1', indicating that this base address register defines a PCI I/O space.

Bits 31-2: I/O Base Address

This bit is a read-only '0' in accordance with the PCI specification for I/O base address configuration registers.



5.6 Interrupt Line, Interrupt Pin, Min_Gnt, and Max_Lat

Configuration Register Name: Interrupt Line, Interrupt Pin, Min_Gnt, and Max_Lat								Register Per: chip
Offset: 3Ch								
Byte 3 Max_Lat	Bit 31	Bit 30	Bit 29	Bit 28	Bit 27	Bit 26	Bit 25	Bit 24
	Max_Lat R:00000000							
Byte 2 Min_Gnt	Bit 23	Bit 22	Bit 21	Bit 20	Bit 19	Bit 18	Bit 17	Bit 16
	Reserved R:XXXXXXXX							
Byte 1 Interrupt Pin	Bit 15	Bit 14	Bit 13	Bit 12	Bit 11	Bit 10	Bit 9	Bit 8
	Interrupt Pin R:00000001							
Byte 0 Interrupt Line	Bit 7	Bit 6	Bit 5	Bit 4	Bit 3	Bit 2	Bit 1	Bit 0
	Interrupt Line RW:00000000							

Bits 7-0: Interrupt Line

For other than PCMCIA-controller-type PCI devices, this field indicates interrupt line routing. Although this register is read/write for PCI compatibility, no interrupt line routing is controlled by this register on the VG-PD6729. Because the VG-PD6729 must dynamically configure interrupt usage, the actual routing to the appropriate interrupt line is made by writing to interrupt-type-specific interrupt control bit settings in the Operation registers (see the **Interrupt and General Control** register).

Bits 15-8: Interrupt Pin

For other than PCMCIA-controller-type PCI devices, this read-only field indicates which interrupt pin the device uses. Because the VG-PD6729 must dynamically configure interrupt usage, the actual connection of interrupt pins is defined by interrupt control bit settings in the Operation registers (see the **Management Interrupt Configuration** register). This field always reads back 01h.

Bits 31-24: Max_Lat

This field indicates the maximum time that can occur between PCI bus accesses to the VG-PD6729 while still efficiently performing transfers to or from PCMCIA cards. The value programmed is in 250-ns increments, based on full-speed PCI_CLK operation. This field always reads back 00h, indicating that there are no major latency requirements.



6.0 Operation Registers

The VG-PD6729’s internal Device Control, Window Mapping, Extension, and Timing registers are accessed through a pair of Operation registers — an **Index** register and a **Data** register.

The **Index** register is accessed at the address programmed in the **Base Address 0** register, and the **Data** register (see “Data” on page 47) is accessed by adding 1 to the address programmed in **Base Address 0**.

Figure 10. Operation Registers as PCI Double-Word I/O Space at Base Address 0 Register (programmed at offset 10h)

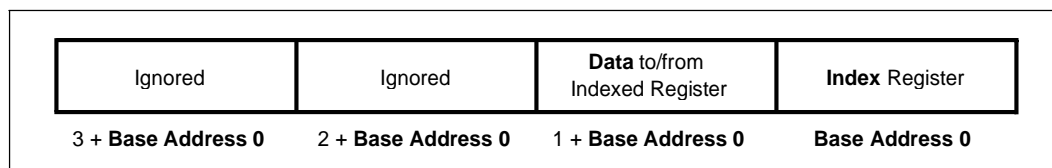

6.1 Index

Register Name: Index							Register Per: chip
Index: n/a							Register Compatibility Type: 365
Bit 7	Bit 6	Bit 5	Bit 4	Bit 3	Bit 2	Bit 1	Bit 0
Reserved	Socket Index	Register Index					
RW:0	RW:0	RW:000000					

Bits 5-0: Register Index

These bits determine which of the 64 possible socket-specific registers will be accessed when the **Data** register is next accessed by the processor. Note that some values of the Register Index field are reserved. see [Table 7](#).

Bit 6: Socket Index

This bit determines which set of socket-specific registers is currently selected. When this bit is a ‘0’, a Socket A register is selected; when this bit is a ‘1’, a Socket B register is selected.

The **Index** register value determines which internal register should be accessed (read or written) in response to each CPU access of the **Data** register. Each of the two possible PCMCIA sockets is allocated 64 of the 256 locations in the internal register index space.

Figure 11. Socket/Register Index Space

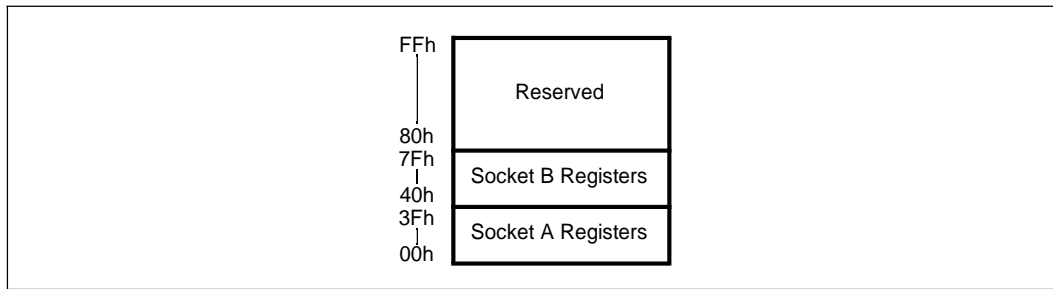

When viewed as a 7-bit value, the contents of this register completely specify a single internal-register byte. For example, when the value of this register is in the range 00h–3Fh, a Socket A register is selected (Socket Index bit is a ‘0’), and when the value of this register is in the range 40h–7Fh, a Socket B register is selected (Socket Index bit is a ‘1’).

The internal register that is accessed when the CPU reads or writes the **Data** register is determined by the current value of the **Index** register, as follows:

Table 7. Index Registers (Sheet 1 of 4)

Register Name	Index Value		Chapter	Page Number
	Socket A	Socket B		
Chip Revision	00h ¹		"Device Control Registers" on page 48	48
Interface Status	01h	41h		49
Power Control	02h	42h		50
Interrupt and General Control	03h	43h		52
Card Status Change	04h	44h		54
Management Interrupt Configuration	05h	45h		55
Mapping Enable	06h	46h		57
I/O Window Control	07h	47h	"I/O Window Mapping Registers" on page 60	60
System I/O Map 0 Start Address Low	08h	48h		61
System I/O Map 0 Start Address High	09h	49h		62
System I/O Map 0 End Address Low	0Ah	4Ah		62
System I/O Map 0 End Address High	0Bh	4Bh		63
System I/O Map 1 Start Address Low	0Ch	4Ch		61
System I/O Map 1 Start Address High	0Dh	4Dh		62
System I/O Map 1 End Address Low	0Eh	4Eh		62
System I/O Map 1 End Address High	0Fh	4Fh	63	
NOTES:				
1. This register affects both sockets (it is not specific to either socket).				
2. This register is only applicable for the extended index 6F register.				
3. This register is only applicable for the extended index 2F register.				



Table 7. Index Registers (Sheet 2 of 4)

Register Name	Index Value		Chapter	Page Number
	Socket A	Socket B		
System Memory Map 0 Start Address Low	10h	50h	"Memory Window Mapping Registers" on page 65	65
System Memory Map 0 Start Address High	11h	51h		66
System Memory Map 0 End Address Low	12h	52h		67
System Memory Map 0 End Address High	13h	53h		67
Card Memory Map 0 Offset Address Low	14h	54h		68
Card Memory Map 0 Offset Address High	15h	55h		64
Misc Control 1	16h	56h	"Extension Registers" on page 70n	70
FIFO Control	17h	57h		71
System Memory Map 1 Start Address Low	18h	58h	"Memory Window Mapping Registers" on page 65	66
System Memory Map 1 Start Address High	19h	59h		66
System Memory Map 1 End Address Low	1Ah	5Ah		67
System Memory Map 1 End Address High	1Bh	5Bh		67
Card Memory Map 1 Offset Address Low	1Ch	5Ch		68
Card Memory Map 1 Offset Address High	1Dh	5Dh		69
Misc Control 2	1Eh ¹		"Extension Registers" on page 70	72
Chip Information	1Fh ¹			74
System Memory Map 2 Start Address Low	20h	60h	"Memory Window Mapping Registers" on page 65	65
System Memory Map 2 Start Address High	21h	61h		66
System Memory Map 2 End Address Low	22h	62h		67
System Memory Map 2 End Address High	23h	63h	"Memory Window Mapping Registers" on page 65	67
Card Memory Map 2 Offset Address Low	24h	64h		68
Card Memory Map 2 Offset Address High	25h	65h		68
ATA Control	26h	66h	"Extension Registers" on page 70	74
Scratchpad	27h	67h	–	–
System Memory Map 3 Start Address Low	28h	68h	"Memory Window Mapping Registers" on page 65	65
System Memory Map 3 Start Address High	29h	69h		66
System Memory Map 3 End Address Low	2Ah	6Ah		67
System Memory Map 3 End Address High	2Bh	6Bh		67
Card Memory Map 3 Offset Address Low	2Ch	6Ch		68
Card Memory Map 3 Offset Address High	2Dh	6Dh		69
NOTES:				
1. This register affects both sockets (it is not specific to either socket).				
2. This register is only applicable for the extended index 6F register.				
3. This register is only applicable for the extended index 2F register.				



PCI-to-PC Card (PCMCIA) Host Controller – VG-PD6729

Table 7. Index Registers (Sheet 3 of 4)

Register Name	Index Value		Chapter	Page Number
	Socket A	Socket B		
Extended Index:	2Eh	6Eh	"Extension Registers" on page 70	76
Scratchpad	Extended index 00h			–
Reserved	Extended index 01h			–
Reserved	Extended index 02h			–
Extension Control 1	Extended index 03h			–
Reserved	Extended index 04h			77
	Extended index 05h			–
System Memory Map 0 Upper Address	Extended index 06h			78
System Memory Map 1 Upper Address	Extended index 07h			78
System Memory Map 2 Upper Address	Extended index 08h			78
System Memory Map 3 Upper Address	Extended index 09h			78
System Memory Map 4 Upper Address	Extended index 0Ah			78
External Data ²	Extended index 25h			78
	Extended index 34h			86
Misc. Control 3	Extended index 35h			79
Mask Revision Byte ³	Extended index 36h			80
Product ID Byte ³	Extended index 37h			80
Device Capability Byte A ³	Extended index 38h			80
Device Capability Byte B ³	Extended index 39h			81
Device Capability Byte C ³	Extended index 3Ah			81
Device Capability Byte D ³	Extended index 3Bh		82	
			82	
			83	
			84	
			85	
Extended Data	2Fh	6Fh		77
System Memory Map 4 Start Address Low	30h	70h	"Memory Window Mapping Registers" on page 65	65
System Memory Map 4 Start Address High	31h	71h		66
System Memory Map 4 End Address Low	32h	72h		67
System Memory Map 4 End Address High	33h	73h		67
Card Memory Map 4 Offset Address Low	34h	74h		68
Card Memory Map 4 Offset Address High	35h	75h		69
Card I/O Map 0 Offset Address Low	36h	76h	"I/O Window Mapping Registers" on page 60	63
Card I/O Map 0 Offset Address High	37h	77h		64
Card I/O Map 1 Offset Address Low	38h	78h		63
Card I/O Map 1 Offset Address High	39h	79h		64
NOTES:				
1. This register affects both sockets (it is not specific to either socket).				
2. This register is only applicable for the extended index 6F register.				
3. This register is only applicable for the extended index 2F register.				



Table 7. Index Registers (Sheet 4 of 4)

Register Name	Index Value		Chapter	Page Number
	Socket A	Socket B		
Setup Timing 0	3Ah	7Ah	"Timing Registers" on page 87	87
Command Timing 0	3Bh	7Bh		88
Recovery Timing 0	3Ch	7Ch		89
Setup Timing 1	3Dh	7Dh		87
Command Timing 1	3Eh	7Eh		88
Recovery Timing 1	3Fh	7Fh		89
Reserved	80h–FFh		–	–
NOTES: 1. This register affects both sockets (it is not specific to either socket). 2. This register is only applicable for the extended index 6F register. 3. This register is only applicable for the extended index 2F register.				

6.2 Data

Register Name: Data							Register Per: chip
Index: n/a							Register Compatibility Type: 365
Bit 7	Bit 6	Bit 5	Bit 4	Bit 3	Bit 2	Bit 1	Bit 0
Data							

The **Data** register is accessed at **Base Address 0 + 1**. This register indicates the contents of the register at the Socket/Register Index selected by the **Index** register.



7.0 Device Control Registers

7.1 Chip Revision

Register Name: Chip Revision						Register Per: chip	
Index: 00h						Register Compatibility Type: 365	
Bit 7	Bit 6	Bit 5	Bit 4	Bit 3	Bit 2	Bit 1	Bit 0
Interface ID		Reserved	Reserved	Revision			
R:10		R:0	R:0	R:0010 ¹			
NOTE:							
1. Value for the current stepping only.							

Bits 3-0: Revision

This field indicates the VG-PD6729’s compatibility with the 82365SL A-step.

Bits 5-4: Reserved

These bits will always read back as ‘0’.

Bits 7-6: Interface ID

00	I/O only.
01	Memory only.
10	Memory and I/O.
11	Reserved.

These bits identify what type of interface this controller supports. The VG-PD6729 supports both memory and I/O interface PCMCIA cards.



7.2 Interface Status

Register Name: Interface Status						Register Per: socket	
Index: 01h						Register Compatibility Type: 365	
Bit 7	Bit 6	Bit 5	Bit 4	Bit 3	Bit 2	Bit 1	Bit 0
1	Card Power On	RDY Ready/Busy*	WP Write Protect	-CD2	-CD1	BVD2	BVD1
R:1 ¹	R:0	R ²	R ³	R ⁴ Card Detect		R ⁵ Battery Voltage Detect	
NOTES: 1. Bit 7 always reads a '1' on the VG-PD6729. 2. Bit 5 indicates the value of the RDY/-IREQ pin (Table 2 on page 18). 3. Bit 4 indicates the value of the WP/-IOIS16 pin (Table 2). 4. Bits 3-2 indicate the inversion of the values of the -CD1 and -CD2 pins (Table 2). 5. Bits 1-0 indicate the values of the BVD1/-STSCHG/-RI and BVD2/-SPKR/-LED pins (Table 2).							

Bits 1-0: Battery Voltage Detect

BVD2 Level	BVD1 Level	Bit 1	Bit 0	PCMCIA Interpretation
Low	Low	0	0	Card data lost
Low	High	0	1	Battery low warning
High	Low	1	0	Card data lost
High	High	1	1	Battery/data okay

In Memory Card Interface mode, these bits are used by PCMCIA support software and firmware to indicate the remaining capacity of the battery in battery-backed cards. In I/O Card Interface mode, bit 0 indicates the state of the BVD1/-STSCHG/-RI pin (Table 2 on page 18). Bit 1 status is not valid in I/O Card Interface mode.

Bits 3-2: Card Detect

-CD2 Level	-CD1 Level	Bit 3	Bit 2	Card Detect Status
High	High	0	0	Either no card or card is not fully inserted
High	Low	0	1	Card is not fully inserted
Low	High	1	0	Card is not fully inserted
Low	Low	1	1	Card is fully inserted

These bits indicate the state of the -CD1 and -CD2 pins (Table 2).



PCI-to-PC Card (PCMCIA) Host Controller – VG-PD6729

Bit 4: Write Protect

0	Card is not write protected.
1	Card is write protected.

In Memory Card Interface mode, this bit indicates the state of the WP/-IOIS16 pin ([Table 2](#)) on the card. This bit is not valid in I/O Card Interface mode.

Bit 5: Ready/Busy*

0	Card is not ready.
1	Card is ready.

In Memory Card Interface mode, this bit indicates the state of the RDY/-IREQ pin ([Table 2](#)) on the card. This status bit is only defined for Memory Card Interface mode and is not valid in I/O Card Interface mode.

Bit 6: Card Power On

0	Power to the card is not on.
1	Power to the card is on.

This status bit indicates whether power to the card is on. Refer to [Table 8](#) for more details.

7.3 Power Control

Register Name: Power Control				Register Per: socket			
Index: 02h				Register Compatibility Type: 365			
Bit 7	Bit 6	Bit 5	Bit 4	Bit 3	Bit 2	Bit 1	Bit 0
Card Enable	Compatibility Bit	Auto-Power	V _{CC} Power	Compatibility Bits		V _{PP1} Power	
RW:0	RW:0	RW:0	RW:0	RW:00		RW:00	



Table 8. Enabling of Socket Power Controls

RST# Level	Both -CD1 and -CD2 are Active (Low)	Power Control Register		Interface Status Register (see page 49)	-VCC_3 and -VCC_5 Levels	VPP_PGM and VPP_VCC Levels
		V _{CC} Power (Bit 4)	Auto- Power (Bit 5)	Card Power On (Bit 6)		
Low	X	X	X	0	Inactive (high)	Inactive (low)
High	X	0	X	0	Inactive (high)	Inactive (low)
High	X	1	0	1	Activated per Misc Control 1 register, bit 1	Activated per Power Control register, bits 1 and 0
High	No	1	1	0	Inactive (high)	Inactive (low)
High	Yes	1	1	1	Activated per Misc Control 1 register, bit 1	Activated per Power Control register, bits 1 and 0

Table 9. Enabling of Output Signals to Socket

RST# Level	Both -CD1 and -CD2 are Active (Low)	Power Control Register		PD6729 Output Signals to Socket
		V _{CC} Power (Bit 4)	Card Enable (Bit 7)	
Low	X	X	X	High impedance
High	No	X	X	High impedance
High	Yes	0	0	High impedance
High	Yes	0	1	Enabled
High	Yes	1	0	High impedance
High	Yes	1	1	Enabled

Bits 1-0: V_{pp1} Power

Bit 1	Bit 0	VPP_PGM	VPP_VCC	PCMCIA Intended Socket Function
0	0	Inactive (low)	Inactive (low)	Zero volts to PCMCIA socket V _{pp1} pin
0	1	Inactive (low)	Active (high) ¹	Selected card V _{CC} to PCMCIA socket V _{pp1} pin
1	0	Active (high) ¹	Inactive (low)	+12V to PCMCIA socket V _{pp1} pin
1	1	Inactive (low)	Inactive (low)	Zero volts to PCMCIA socket V _{pp1} pin

NOTE:

1. Under conditions where V_{pp1} power is activated. See Table 8.

These bits control the power to the V_{pp1} pin of the PCMCIA card.



Bit 4: V_{CC} Power

0	Power is not applied to the card: the -VCC_3 and -VCC_5 socket power control pins are inactive (high).
1	Power is applied to the card: if bit 5 is a '0', or bit 5 is a '1' and -CD2 and -CD1 are active low,

Depending on the value of bit 5 below, setting this bit to a '1' applies power to the card. The V_{CC} 3.3V bit (see bit 1, "Misc Control 1" on page 70) determines whether 3.3V or 5V power is applied. Note that this bit is reset to a '0' when a card is removed from the socket unless the auto-power-off feature is disabled by setting **Extension Control 1** register bit 1 to a '1'; a write is required to reactivate power to the card.

Extension Control 1 register bit 0, when set to '1', prevents modification of the VCC Power bit by writes to the Power Control register.

Bit 5: Auto-Power

0	V _{CC} and V _{PP1} power control signals are activated independent of the socket's -CD2 and -CD1 input levels.
1	V _{CC} and V _{PP1} power control signals are only activated if the socket's -CD2 and -CD1 inputs are both active (low).

When this bit is set to a '1', the VG-PD6729 allows power to the card to be turned on and off automatically with the insertion and removal of a PCMCIA card.

Bit 7: Card Enable

0	Outputs to card socket are not enabled and are floating.
1	Outputs to card socket are enabled if -CD1 and -CD2 are active low and bit 4 is a '1'.

When this bit is a '1', the outputs to the PCMCIA card are enabled if a card is present and card power is being supplied. The pins affected include -CE2, -CE1, -IORD, -IOWR, -OE, -REG, RESET. A[25:0]. D[15:0]. and -WE.

7.4 Interrupt and General Control

Register Name: Interrupt and General Control				Register Per: socket			
Index: 03h				Register Compatibility Type: 365			
Bit 7	Bit 6	Bit 5	Bit 4	Bit 3	Bit 2	Bit 1	Bit 0
Ring Indicate Enable	Card Reset*	Card Is I/O	Manage Int Enable		IRQ Level		
RW:0	RW:0	RW:0	RW:0		RW:0000		



Bits 3-0: IRQ Level

0000	IRQ disabled
0001	Reserved
0010	Reserved
0011	IRQ3 (INTA#)
0100	IRQ4 (INTB#)
0101	IRQ5 (INTC#)
0110	Reserved
0111	IRQ7 (INTD#)
1000	Reserved
1001	IRQ9
1010	IRQ10
1011	IRQ11
1100	IRQ12
1101	Reserved
1110	IRQ14 (This output can alternately be used as external clock input.)
1111	IRQ15 (This output can alternately be used as ring indicate output.)

These bits determine which IRQ will occur when the card causes an interrupt through the RDY/-IREQ pin on the PCMCIA socket.

Bit 4: Manage Int Enable

0	Management IRQ (see “Bits 7-4: Management IRQ” on page 57) specifies management interrupt bits.
1	Reserved. No hardware function in the VG-PD6729.

This bit was created to determine how management interrupts occur on ISA-based systems. It is included for software compatibility. Because there is no -INTR pin on the PCI bus, setting this bit to a ‘1’ would cause management interrupts not to occur.

Bit 5: Card Is I/O

0	Sets Memory Card Interface mode. The card socket is configured to support memory-only-type cards. All dual-function socket interface pins are defined to perform memory-only-type interface functions.
1	Sets I/O Card Interface mode. The card socket is configured to support combined I/O-and-memory-type cards. All dual-function socket interface pins are defined to perform all I/O and basic memory type interface functions.

This bit determines how dual-function socket interface pins will be used. For more information on specific pins, refer to [Table 2 on page 18](#).



Bit 6: Card Reset*

0	The RESET signal to the card socket is set active (high for normal, low for ATA mode).
1	The RESET signal to the card socket is set inactive (low for normal, high for ATA mode).

This bit determines whether the RESET signal (Table 2) to the card is active or inactive. When the Card Enable bit (see “Bit 7: Card Enable” on page 52) is a ‘0’, the RESET signal to the card is high impedance. See “ATA Mode Operation” on page 91 for further description of ATA mode functions.

Bit 7: Ring Indicate Enable

0	BVD1/-STSCHG/-RI pin is status change function.
1	BVD1/-STSCHG/-RI pin is ring indicate input pin from card.

In I/O Card Interface mode, this bit determines whether the -STSCHG input pin is used to activate the IRQ15 pin in conjunction with the IRQ15 Is RI Out bit (Misc Control 2 bit 7, see “Bit 7: IRQ15/RI OUT* Is RI Out” on page 73). This bit is not valid in Memory Card Interface mode.

7.5 Card Status Change

Register Name: Card Status Change						Register Per: socket	
Index: 04h						Register Compatibility Type: 365	
Bit 7	Bit 6	Bit 5	Bit 4	Bit 3	Bit 2	Bit 1	Bit 0
				Card Detect Change	Ready Change	Battery Warning Change	Battery Dead Or Status Change
R:0	R:0	R:0	R:0	R:0	R:0	R:0	R:0

This register indicates the source of a management interrupt generated by the VG-PD6729.

Note: The corresponding bit in the **Management Interrupt Configuration** register must be set to a ‘1’ to enable each specific status change detection.

Bit 0: Battery Dead Or Status Change

0	A transition (from high to low in Memory Card Interface mode or either high to low or low to high in I/O Card Interface mode) on the BVD1/-STSCHG/-RI pin has not occurred since this register was last read.
1	A transition on the BVD1/-STSCHG/-RI pin has occurred.



In Memory Card Interface mode, this bit is set to a ‘1’ when the BVD1/-STSCHG/-RI pin (see Table 2) changes from high to low, indicating a battery dead condition. In I/O Card Interface mode, this bit is set to a ‘1’ when the BVD1/-STSCHG/-RI pin changes from either high to low or low to high. In I/O Card Interface mode, the function of this bit is not affected by bit 7 of the **Interrupt and General Control** register. This bit is reset to a ‘0’ whenever this register is read.

Bit 1: Battery Warning Change

0	A transition (from high to low) on the BVD2/-SPKR/-LED pin has not occurred since this register was last read.
1	A transition on the BVD2/-SPKR/-LED pin has occurred.

In Memory Card Interface mode, this bit is set to a ‘1’ when the BVD2/-SPKR/-LED pin changes from high to low, indicating a battery warning. This bit is not valid in I/O Card Interface mode. This bit is reset to a ‘0’ whenever this register is read.

Bit 2: Ready Change

0	A transition on the RDY/-IREQ pin has not occurred since this register was last read.
1	A transition on the RDY/-IREQ pin has occurred.

In Memory Card Interface mode, this bit is a ‘1’ when a change has occurred on the RDY/-IREQ pin (see Table 2). In I/O Card Interface mode, this bit always reads a ‘0’. This bit is reset to a ‘0’ whenever this register is read.

Bit 3: Card Detect Change

0	A transition on neither the -CD1 nor the -CD2 pin has occurred since this register was last read.
1	A transition on either the -CD1 or the -CD2 pin or both has occurred.

This bit is set to a ‘1’ when a change has occurred on the -CD1 or -CD2 pin (see Table 2). This bit is reset to a ‘0’ whenever this register is read.

7.6 Management Interrupt Configuration

Register Name: Management Interrupt Configuration				Register Per: socket			
Index: 05h				Register Compatibility Type: 365			
Bit 7	6	5	4	Bit 3	Bit 2	Bit 1	Bit 0
Management IRQ				Card Detect Enable	Ready Enable	Battery Warning Enable	Battery Dead Or Status Change Enable
RW:0000				RW:0	RW:0	RW:0	RW:0



This register controls which status changes cause management interrupts as well as at which pin the management interrupts will appear.

Bit 0: Battery Dead Or Status Change Enable

0	Battery Dead Or Status Change management interrupt disabled.
1	If Battery Dead Or Status Change bit is a '1', a management interrupt will occur.

When this bit is a '1', a management interrupt will occur when the **Card Status Change** register's Battery Dead Or Status Change bit (see "[Bit 0: Battery Dead Or Status Change](#)" on page 54) is a '1'. This allows management interrupts to be generated on changes in level of the BVD1/-STSCHG/-RI pin.

Bit 1: Battery Warning Enable

0	Battery Warning Change management interrupt disabled.
1	If Battery Warning Change bit is a '1', a management interrupt will occur.

When this bit is a '1', a management interrupt will occur when the **Card Status Change** register's Battery Warning Change bit (see "[Bit 1: Battery Warning Change](#)" on page 55) is a '1'. This allows management interrupts to be generated on changes in level of the BVD2/-SPKR/-LED pin. This bit is not valid in I/O Card Interface mode.

Bit 2: Ready Enable

0	Ready Change management interrupt disabled.
1	If Ready Change bit is a '1', a management interrupt will occur.

When this bit is a '1', a management interrupt will occur when the **Card Status Change** register's Ready Change bit (see "[Bit 1: Battery Warning Change](#)" on page 55) is a '1'. This allows management interrupts to be generated on changes in level of the RDY/-IREQ pin.

Bit 3: Card Detect Enable

0	Card Detect Change management interrupt disabled.
1	If Card Detect Change bit is a '1', a management interrupt will occur.

When this bit is a '1', a management interrupt will occur when the **Card Status Change** register's Card Detect Change bit (see "[Bit 3: Card Detect Change](#)" on page 55) is a '1'. This allows management interrupts to be generated on changes in level of the -CD1 and -CD2 pins.



Bits 7-4: Management IRQ

0000	IRQ disabled
0001	Reserved
0010	Reserved
0011	IRQ3 (INTA#)
0100	IRQ4 (INTB#)
0101	IRQ5 (INTC#)
0110	Reserved
0111	IRQ7 (INTD#)
1000	Reserved
1001	IRQ9
1010	IRQ10
1011	IRQ11
1100	IRQ12
1101	Reserved
1110	IRQ14 (This output can alternately be used as external clock input.)
1111	IRQ15 (This output can alternately be used as ring indicate output.)

These bits determine which interrupt pin will be used for card status change management interrupts.

7.7 Mapping Enable

Register Name: Mapping Enable							Register Per: socket
Index: 06h							Register Compatibility Type: 365
Bit 7	Bit 6	Bit 5	Bit 4	Bit 3	Bit 2	Bit 1	Bit 0
I/O Map 1 Enable	I/O Map 0 Enable	Compatibility Bit	Memory Map 4 Enable	Memory Map 3 Enable	Memory Map 2 Enable	Memory Map 1 Enable	Memory Map 0 Enable
RW:0	RW:0	R:0	RW:0	RW:0	RW:0	RW:0	RW:0

Bit 0: Memory Map 0 Enable

0	Memory Window Mapping registers for Memory Window 0 disabled.
1	Memory Window Mapping registers for Memory Window 0 enabled.

When this bit is a '1', the Memory Window Mapping registers for Memory Window 0 are enabled and the controller will respond to memory accesses in the memory space defined by those registers.



Bit 1: Memory Map 1 Enable

0	Memory Window Mapping registers for Memory Window 1 disabled.
1	Memory Window Mapping registers for Memory Window 1 enabled.

When this bit is a ‘1’, the Memory Window Mapping registers for Memory Window 1 are enabled and the controller will respond to memory accesses in the memory space defined by those registers.

Bit 2: Memory Map 2 Enable

0	Memory Window Mapping registers for Memory Window 2 disabled.
1	Memory Window Mapping registers for Memory Window 2 enabled.

When this bit is a ‘1’, the Memory Window Mapping registers for Memory Window 2 are enabled and the controller will respond to memory accesses in the memory space defined by those registers.

Bit 3: Memory Map 3 Enable

0	Memory Window Mapping registers for Memory Window 3 disabled.
1	Memory Window Mapping registers for Memory Window 3 enabled.

When this bit is a ‘1’, the Memory Window Mapping registers for Memory Window 3 are enabled and the controller will respond to memory accesses in the memory space defined by those registers.

Bit 4: Memory Map 4 Enable

0	Memory Window Mapping registers for Memory Window 4 disabled.
1	Memory Window Mapping registers for Memory Window 4 enabled.

When this bit is a ‘1’, the Memory Window Mapping registers for Memory Window 4 are enabled and the controller will respond to memory accesses in the memory space defined by those registers.

Bit 6: I/O Map 0 Enable

0	I/O Window Mapping registers for I/O Window 0 disabled.
1	I/O Window Mapping registers for I/O Window 0 enabled.

When this bit is a ‘1’, the I/O Window Mapping registers for I/O Window 0 are enabled and the controller will respond to I/O accesses in the I/O space defined by those registers.



Bit 7: I/O Map 1 Enable

0	I/O Window Mapping registers for I/O Window 1 disabled.
1	I/O Window Mapping registers for I/O Window 1 enabled.

When this bit is a '1', the I/O Window Mapping registers for I/O Window 1 are enabled and the controller will respond to I/O accesses in the I/O space defined by those registers.



8.0 I/O Window Mapping Registers

Caution: Be sure that the I/O windows do not map to the **Base Address 0** register programmed at offset 10h.

8.1 I/O Window Control

Register Name: I/O Window Control						Register Per: socket	
Index: 07h						Register Compatibility Type: 365	
Bit 7	Bit 6	Bit 5	Bit 4	Bit 3	Bit 2	Bit 1	Bit 0
Timing Register Select 1	Compatibility Bit	Auto-Size I/O Window 1	I/O Window 1 Size	Timing Register Select 0	Compatibility Bit	Auto-Size I/O Window 0	I/O Window 0 Size
RW:0	RW:0	RW:0	RW:0	RW:0	RW:0	RW:0	RW:0

Bit 0: I/O Window 0 Size

0	8-bit data path to I/O Window 0.
1	16-bit data path to I/O Window 0.

When bit 1 of this register is a '0', this bit determines the width of the data path for I/O Window 0 accesses to the card. When bit 1 is a '1', this bit is ignored.

Bit 1: Auto-Size I/O Window 0

0	I/O Window 0 Size (see bit 0 of this register) determines the data path for I/O Window 0 accesses.
1	The data path to I/O Window 0 is determined by the -IOIS16 level returned by the card.

This bit controls the method that the width of the data path for I/O Window 0 accesses to the card is determined. Note that when this bit is a '1', the -IOIS16 signal (see [Table 2](#)) determines the width of the data path to the card.

Bit 3: Timing Register Select 0

0	Accesses made with timing specified in Timer Set 0 registers.
1	Accesses made with timing specified in Timer Set 1 registers.

This bit determines the access timing specification (“[Timing Registers](#)” on page 87) for I/O Window 0.



Bit 4: I/O Window 1 Size

0	8-bit data path to I/O Window 1.
1	16-bit data path to I/O Window 1.

When bit 5 of this register is a ‘0’, this bit determines the width of the data path for I/O Window 1 accesses to the card. When bit 5 is a ‘1’, this bit is ignored.

Bit 5: Auto-Size I/O Window 1

0	I/O Window 1 Size (see bit 4 of this register) determines the data path for I/O Window 1 accesses.
1	The data path to I/O Window 1 will be determined based on -IOIS16 returned by the card.

This bit controls the method that the width of the data path for I/O Window 1 accesses to the card is determined. Note that when this bit is a ‘1’, the -IOIS16 signal (Table 2) determines the width of the data path to the card. This bit must be set to a ‘1’ for correct ATA mode operation (see “ATAMode Operation” on page 91).

Bit 7: Timing Register Select 1

0	Accesses made with timing specified in Timer Set 0.
1	Accesses made with timing specified in Timer Set 1.

This bit determines the access timing specification (see “Timing Registers” on page 87) for I/O Window 1.

8.2 System I/O Map 0-1 Start Address Low

Register Name: System I/O Map 0-1 Start Address Low							Register Per: socket
Index: 08h, 0Ch							Register Compatibility Type: 365
Bit 7	Bit 6	Bit 5	Bit 4	Bit 3	Bit 2	Bit 1	Bit 0
Start Address 7-0							
RW:00000000							

There are two separate System I/O Map Start Address Low registers, each with identical fields. These registers are located at the following indexes:

Index	(Socket A) System I/O Map Start Address Low
08h	System I/O Map 0 Start Address Low
0Ch	System I/O Map 1 Start Address Low



Bits 7-0: Start Address 7-0

This register contains the least-significant byte of the address that specifies where in the I/O space the corresponding I/O map will begin. I/O accesses that are equal or above this address and equal or below the corresponding System I/O Map End Address will be mapped into the I/O space of the corresponding PCMCIA card.

The most-significant byte is located in the **System I/O Map 0-1 Start Address High** register.

8.3 System I/O Map 0-1 Start Address High

Register Name: System I/O Map 0-1 Start Address High						Register Per: socket	
Index: 09h, 0Dh						Register Compatibility Type: 365	
Bit 7	Bit 6	Bit 5	Bit 4	Bit 3	Bit 2	Bit 1	Bit 0
Start Address 15-8							
RW:00000000							

There are two separate System I/O Map Start Address High registers, each with identical fields. These registers are located at the following indexes:

Index	(Socket A) System I/O Map Start Address High
09h	System I/O Map 0 Start Address High
0Dh	System I/O Map 1 Start Address High

Bits 15-8: Start Address 15-8

This register contains the most-significant byte of the Start Address. See the description of the Start Address field associated with bits 7-0 of the **System I/O Map 0-1 Start Address Low** register.

8.4 System I/O Map 0-1 End Address Low

Register Name: System I/O Map 0-1 End Address Low						Register Per: socket	
Index: 0Ah, 0Eh						Register Compatibility Type: 365	
Bit 7	Bit 6	Bit 5	Bit 4	Bit 3	Bit 2	Bit 1	Bit 0
End Address 7-0							
RW:00000000							

There are two separate System I/O Map End Address Low registers, each with identical fields. These registers are located at the following indexes:

Index	(Socket A) System I/O Map End Address Low
0Ah	System I/O Map 0 End Address Low
0Eh	System I/O Map 1 End Address Low



Bits 7-0: End Address 7-0

This register contains the least-significant byte of the address that specifies where in the I/O space the corresponding I/O map will end. I/O accesses that are equal or below this address and equal or above the corresponding System I/O Map Start Address will be mapped into the I/O space of the corresponding PCMCIA card.

The most-significant byte is located in the **System I/O Map 0-1 End Address High** register.

8.5 System I/O Map 0-1 End Address High

Register Name: System I/O Map 0-1 End Address High							Register Per: socket
Index: 0Bh, 0Fh							Register Compatibility Type: 365
Bit 7	Bit 6	Bit 5	Bit 4	Bit 3	Bit 2	Bit 1	Bit 0
End Address 15-8							
RW:00000000							

There are two separate System I/O Map End Address High registers, each with identical fields. These registers are located at the following indexes:

Index	(Socket A) System I/O Map End Address High
0Bh	System I/O Map 0 End Address High
0Fh	System I/O Map 1 End Address High

Bits 15-8: End Address 15-8

This register contains the most-significant byte of the End Address. See the description of the End Address field associated with bits 7-0 of the **System I/O Map 0-1 End Address Low** register.

8.6 Card I/O Map 0-1 Offset Address Low

Register Name: Card I/O Map 0-1 Offset Address Low							Register Per: socket
Index: 36h, 38h							Register Compatibility Type: ext.
Bit 7	Bit 6	Bit 5	Bit 4	Bit 3	Bit 2	Bit 1	Bit 0
Offset Address 7-1							0 ¹
RW:00000000							RW:0
NOTE:							
1. This bit must be programmed to '0'.							

There are two separate Card I/O Map Offset Address Low registers, each with identical fields. These registers are located at the following indexes:



PCI-to-PC Card (PCMCIA) Host Controller – VG-PD6729

Index	(Socket A) Card I/O Map Offset Address Low
36h	Card I/O Map 0 Offset Address Low
38h	Card I/O Map 1 Offset Address Low

Bits 7-1: Offset Address 7-1

This register contains the least-significant byte of the quantity that will be added to the system I/O address that determines where in the PCMCIA card's I/O map the I/O access will occur.

The most-significant byte is located in the **Card I/O Map 0-1 Offset Address High** register.

8.7 Card I/O Map 0-1 Offset Address High

Register Name: Card I/O Map 0-1 Offset Address High						Register Per: socket	
Index: 37h, 39h						Register Compatibility Type: ext.	
Bit 7	Bit 6	Bit 5	Bit 4	Bit 3	Bit 2	Bit 1	Bit 0
Offset Address 15-8							
RW:00000000							

There are two separate Card I/O Map Offset Address High registers, each with identical fields. These registers are located at the following indexes:

Index	(Socket A) Card I/O Map Offset Address High
37h	Card I/O Map 0 Offset Address High
39h	Card I/O Map 1 Offset Address High

Bits 15-8: Offset Address 15-8

This register contains the most-significant byte of the Offset Address. See the description of the End Address field associated with bits 7-1 of the **Card I/O Map 0-1 Offset Address Low** register.



9.0 Memory Window Mapping Registers

The following information about the memory map windows is important:

- The memory window mapping registers determine where in the PCI memory space and PC card memory space accesses will occur. There are five memory windows that can be used independently.
- The memory windows are enabled and disabled using the **Mapping Enable** register (see “[Mapping Enable](#)” on page 57).
 - To specify where in the PCI space a memory window is mapped, start and end addresses are specified. A memory window is selected whenever the appropriate Memory Map Enable bit (see “[Mapping Enable](#)”) is set and the following conditions are true:
 - The PCI address is greater than or equal to the appropriate **System Memory Map Start Address** register (see “[System Memory Map 0-4 Start Address Low](#)” on page 65).
 - The PCI address is less than or equal to the appropriate **System Memory Map End Address** register (see “[System Memory Map 0-4 End Address Low](#)”).
 - The **System Memory Map Upper Address** register (see “[System Memory Map 0-4 Upper Address](#)” on page 78) is equal to the upper PCI address.
- Start and end addresses are specified with PCI Address bits 31-12. This sets the minimum size of a memory window to 4K bytes. Memory windows are specified in the PCI memory address space.
- To ensure proper operation, none of the memory windows can overlap in the PCI address space.

9.1 System Memory Map 0-4 Start Address Low

Register Name: System Memory Map 0-4 Start Address Low							Register Per: socket
Index: 10h, 18h, 20h, 28h, 30h							Register Compatibility Type: 365
Bit 7	Bit 6	Bit 5	Bit 4	Bit 3	Bit 2	Bit 1	Bit 0
Start Address 19-12							
RW:00000000							

There are five separate System Memory Map Start Address Low registers, each with identical fields. These registers are located at the following indexes:

Index	(Socket A) System Memory Map Start Address Low
10h	System Memory Map 0 Start Address Low
18h	System Memory Map 1 Start Address Low
20h	System Memory Map 2 Start Address Low
28h	System Memory Map 3 Start Address Low
30h	System Memory Map 4 Start Address Low



Bits 7-0: Start Address 19-12

This register contains the least-significant byte of the address that specifies where in the memory space the corresponding memory map will begin. Memory accesses that are equal or above this address and equal or below the corresponding System Memory Map End Address will be mapped into the memory space of the corresponding PCMCIA card.

The most-significant four bits are located in the **System Memory Map 0-4 Start Address High** register.

9.2 System Memory Map 0-4 Start Address High

Register Name: System Memory Map 0-4 Start Address High				Register Per: socket			
Index: 11h, 19h, 21h, 29h, 31h				Register Compatibility Type: 365			
Bit 7	Bit 6	Bit 5	Bit 4	Bit 3	Bit 2	Bit 1	Bit 0
Window Data Size	Compatibility Bit	Scratchpad Bits		Start Address 23-20			
RW:0	RW:0	RW:00		RW:0000			

There are five separate System Memory Map Start Address High registers, each with identical fields. These registers are located at the following indexes:

Index	(Socket A) System Memory Map Start Address High
11h	System Memory Map 0 Start Address High
19h	System Memory Map 1 Start Address High
21h	System Memory Map 2 Start Address High
29h	System Memory Map 3 Start Address High
31h	System Memory Map 4 Start Address High

Bits 3-0: Start Address 23-20

This field contains the most-significant four bits of the Start Address. See the description of the Start Address field associated with bits 7-0 of the **System Memory Map 0-4 Start Address Low** register.

Bit 7: Window Data Size

0	8-bit data path to the card.
1	16-bit data path to the card.

This bit determines the data path size to the card.



9.3 System Memory Map 0-4 End Address Low

Register Name: System Memory Map 0-4 End Address Low						Register Per: socket	
Index: 12h, 1Ah, 22h, 2Ah, 32h						Register Compatibility Type: 365	
Bit 7	Bit 6	Bit 6	Bit 4	Bit 3	Bit 2	Bit 1	Bit 0
End Address 19-12							
RW:00000000							

There are five separate System Memory Map End Address Low registers, each with identical fields. These registers are located at the following indexes:

Index	(Socket A) System Memory Map End Address Low
12h	System Memory Map 0 End Address Low
1Ah	System Memory Map 1 End Address Low
22h	System Memory Map 2 End Address Low
2Ah	System Memory Map 3 End Address Low
32h	System Memory Map 4 End Address Low

Bits 7-0: End Address 19-12

This register contains the least-significant byte of the address that specifies where in the memory space the corresponding memory map will end. Memory accesses that are equal or below this address and equal or above the corresponding System Memory Map Start Address will be mapped into the memory space of the corresponding PCMCIA card.

The most-significant four bits are located in the **System Memory Map 0-4 End Address High** register.

9.4 System Memory Map 0-4 End Address High

Register Name: System Memory Map 0-4 End Address High						Register Per: socket	
Index: 13h, 1Bh, 23h, 2Bh, 33h						Register Compatibility Type: 365	
Bit 7	Bit 6	Bit 5	Bit 4	Bit 3	Bit 2	Bit 1	Bit 0
Card Timer Select		Scratchpad Bits		End Address 23-20			
RW:00		RW:00		RW:0000			

There are five separate System Memory Map End Address High registers, each with identical fields. These registers are located at the following indexes:

Index	(Socket A) System Memory Map End Address High
13h	System Memory Map 0 End Address High
1Bh	System Memory Map 1 End Address High



PCI-to-PC Card (PCMCIA) Host Controller – VG-PD6729

23h	System Memory Map 2 End Address High
2Bh	System Memory Map 3 End Address High
33h	System Memory Map 4 End Address High

Bits 3-0: End Address 23-20

This field contains the most-significant four bits of the End Address. See the description of the End Address field associated with bits 7-0 of the **System Memory Map 0-4 End Address Low** register. Note that the upper memory addresses are stored in the **System Memory Map Upper Address** register.

Bits 7-6: Card Timer Select

00	Selects Timer Set 0.
01	Selects Timer Set 1.
10	Selects Timer Set 1.
11	Selects Timer Set 1.

This field selects the timer set. Timer Set 0 and 1 reset to values compatible with standard PCI and three-wait-state cycles (see “[Setup Timing 0-1](#)” on page 87).

9.5 Card Memory Map 0-4 Offset Address Low

Register Name: Card Memory Map 0-4 Offset Address Low						Register Per: socket	
Index: 14h, 1Ch, 24h, 2Ch, 34h						Register Compatibility Type: 365	
Bit 7	Bit 6	Bit 5	Bit 4	Bit 3	Bit 2	Bit 1	Bit 0
Offset Address 19-12							
RW:00000000							

There are five separate Card Memory Map Offset Address Low registers, each with identical fields. These registers are located at the following indexes:

Index	(Socket A) Card Memory Map Offset address Low
14h	Card Memory Map 0 Offset Address Low
1Ch	Card Memory Map 1 Offset Address Low
24h	Card Memory Map 2 Offset Address Low
2Ch	Card Memory Map 3 Offset Address Low
34h	Card Memory Map 4 Offset Address Low

Bits 7-0: Offset Address 19-12

This register contains the least-significant byte of the quantity that will be added to the system memory address that determines where in the PCMCIA card’s memory map the memory access will occur.



The most-significant six bits are located in the **Card Memory Map 0-4 Offset Address High** register.

9.6 Card Memory Map 0-4 Offset Address High

Register Name: Card Memory Map 0-4 Offset Address High						Register Per: socket	
Index: 15h, 1Dh, 25h, 2Dh, 35h						Register Compatibility Type: 365	
Bit 7	Bit 6	Bit 5	Bit 4	Bit 3	Bit 2	Bit 1	Bit 0
Write Protect	REG Setting	Offset Address 25-20					
RW:0	RW:0	RW:000000					

There are five separate Card Memory Map Offset Address High registers, each with identical fields. These registers are located at the following indexes:

Index	(Socket A) Memory Map Address Offset High
15h	Card Memory Map 0 Offset Address High
1Dh	Card Memory Map 1 Offset Address High
25h	Card Memory Map 2 Offset Address High
2Dh	Card Memory Map 3 Offset Address High
35h	Card Memory Map 4 Offset Address High

Bits 5-0: Offset Address 25-20

This field contains the most-significant six bits of the Offset Address. See the description of the Offset Address field associated with bits 7-0 of the **Card Memory Map 0-4 Offset Address Low** register.

Bit 6: REG Setting

0	-REG (see Table 2 on page 18) is not active for accesses made through this window.
1	-REG is active for accesses made through this window.

This bit determines whether -REG ([Table 2](#)) is active for accesses made through this window. Card Information Structure (CIS) memory is accessed by setting this bit to a '1'.

Bit 7: Write Protect

0	Writes to the card through this window are allowed.
1	Writes to the card through this window are inhibited.

This bit determines whether writes to the card through this window are allowed.



10.0 Extension Registers

10.1 Misc Control 1

Register Name: Misc Control 1						Register Per: socket	
Index: 16h						Register Compatibility Type: ext.	
Bit 7	Bit 6	Bit 5	Bit 4	Bit 3	Bit 2	Bit 1	Bit 0
Inpack Enable	Scratchpad Bits		Speaker Enable	Pulse System IRQ	Pulse Management Interrupt	V _{CC} 3.3V	Multimedia Enable
RW:0	RW:00		RW:0	RW:0	RW:0	RW:0	RW:0

Bit 0: Multimedia Enable

0	Socket address lines are normal.
1	Socket address lines A[25:4] are high-impedance.

This bit tristates socket address lines A[25:4]. All other aspects of the socket are not affected by this bit.

Note: Bit 7 in the Extended register 25h, the **Misc Control 3** register must be set to a '1' for this bit to enable tristating of address lines [25-4].

Bit 1: V_{CC} 3.3V

0	-VCC_5 activated when card power is to be applied.
1	-VCC_3 activated when card power is to be applied.

This bit determines which output pin is used to enable V_{CC} power to the socket when card power is applied; this bit is used in conjunction with bits 5-4 of the **Power Control** register (see [“Power Control” on page 50](#)).

Bit 2: Pulse Management Interrupt

0	Interrupts are passed to the IRQ[XX] pin as level-sensitive.
1	When an interrupt occurs, the IRQ[XX] pin is driven with the pulse train shown in Table 12 and allows for interrupt sharing.

This bit selects Level or Pulse mode operation of the IRQ[XX] pin (see [Table 1 on page 15](#)). Note that a clock must be present on PCI_CLK or IRQ14/EXT_CLK for pulsed interrupts to work. Refer to [“System Interrupt Timing” on page 100](#) for more information on interrupt timing.

Figure 12. Pulse Mode Interrupts

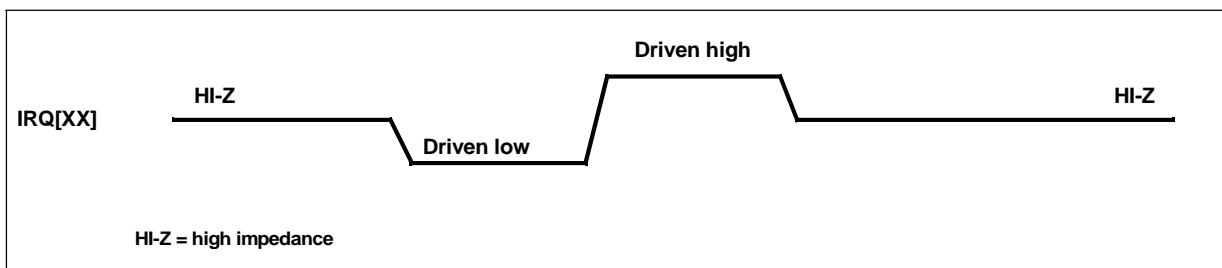

Bit 3: Pulse System IRQ

0	Interrupts are passed to the IRQ[XX] pin as level-sensitive.
1	When an interrupt occurs, the IRQ[XX] pin is driven with the pulse train shown in Figure 12 and allows for interrupt sharing.

This bit selects Level or Pulse mode operation of the IRQ[XX] pins (see Table 1 on page 15).

Bit 4: Speaker Enable

0	SPKR_OUT* is three-stated.
1	SPKR_OUT* is driven from the XOR of -SPKR from each enabled socket.

This bit determines whether the card -SPKR pin will drive SPKR_OUT* (see Table 3).

Bit 7: Inpack Enable

0	-INPACK pin (see Table 2) ignored.
1	-INPACK pin used to control data bus drivers during I/O read from the socket.

The -INPACK function is not applicable in PCI bus environments. This bit is provided for backward-compatibility. Its setting has no effect on operations of the VG-PD6729.

10.2 FIFO Control

Register Name: FIFO Control				Register Per: socket			
Index: 17h				Register Compatibility Type: ext.			
Bit 7	Bit 6	Bit 5	Bit 4	Bit 3	Bit 2	Bit 1	Bit 0
FIFO Status / Flush FIFO				Scratchpad Bits			
RW:1				RW:0000000			



Bit 7: FIFO Status / Flush FIFO

Value	I/O Read	I/O Write
0	FIFO not empty	No operation occurs (default at reset)
1	FIFO empty	Flush the FIFO

This bit controls FIFO operation and reports FIFO status. When this bit is set to a ‘1’ during write operations, all data in the FIFO is lost. During read operations, when this bit is a ‘1’, the FIFO is empty. During read operations when this bit is a ‘0’, the FIFO has valid data.

This bit is used to ensure the FIFO is empty before changing any registers; registers should not be modified while the write FIFO is not empty.

FIFO contents will be lost whenever any of the following occur:

- RST# pin (Table 1) is a ‘0’.
- The card is removed.
- V_{CC} Power bit (see “Bit 4: VCC Power” on page 52) is programmed to a ‘0’.

10.3 Misc Control 2

Register Name: Misc Control 2						Register Per: chip	
Index: 1Eh						Register Compatibility Type: ext.	
Bit 7	Bit 6	Bit 5	Bit 4	Bit 3	Bit 2	Bit 1	Bit 0
IRQ15/ RI_OUT* Is RI Out	Reserved		Reserved	5V Core	Suspend Mode	Low-Power Dynamic Mode	External Clock Enable
RW:0	RW:00		RW:0	RW:0	RW:0	RW:1	RW:0

Bit 0: External Clock Enable

0	External clock is disabled; clocking of socket interfaces provided by PCI_CLK
1	IRQ14/EXT_CLK pin will be used as an external clock input to provide clocking of socket interface.

This bit determines whether the external clock option is enabled. When set to a ‘1’, a clock supplied to IRQ14/EXT_CLK will be internally divided by two and used as the internal clock for the socket interfaces. This feature facilitates PCMCIA transfer cycles when the PCI bus clock is stopped to conserve power. When set to a ‘0’, the PCI_CLK input is divided by two and used as the internal clock, which drives the socket interfaces and specifies their timing.



Bit 1: Low-Power Dynamic Mode

0	Clock runs always.
1	Normal operation, stop clock when possible.

This bit determines whether Low-power Dynamic mode is enabled. Leaving this bit set to ‘1’ allows automatic reduction in power consumption during periods of inactivity.

Bit 2: Suspend Mode

0	Normal operation.
1	Stop internal clock, enable all Low-power modes, and disable socket access.

This bit enables Suspend mode. No registers other than this (index 1E) should be written when in Suspend mode should not be expected. Access cycles to cards in sockets are not allowed in Suspend mode.

Bit 3: 5V Core

0	Normal operation: use when CORE_VDD pin is connected to 3.3 volts.
1	Selects input thresholds for use when 5.0 volts is connected to the PD6729 CORE_VDD pin.

This bit selects input threshold circuits. This bit must be set to a ‘1’ when the CORE_VDD pin is connected to 5.0 volts to provide TTL-compatible input thresholds at card socket.

Bit 7: IRQ15/RI_OUT* Is RI Out

0	Normal IRQ15 operation on the IRQ15/RI_OUT* pin.
1	IRQ15/RI_OUT* is connected to ring indicate pin on the system logic.

This bit determines the function of the IRQ15/RI_OUT* pin. When this bit is set to a ‘1’, IRQ15/RI_OUT* can be used to trigger restoration of system activity when a high-to-low change is detected on the BVD1/-STSCHG/-RI pin.



10.4 Chip Information

Register Name: Chip Information							Register Per: chip
Index: 1Fh							Register Compatibility Type: ext.
Bit 7	Bit 6	Bit 5	Bit 4	Bit 3	Bit 2	Bit 1	Bit 0
VG-PD6729 PC Card Controller Identification Level		VG-PD6729 Revision					
R:11		R:nnnnnnn ¹					
NOTE:							
1. This read-only value depends on the revision level of the VG-PD6729 chip. A value of 21h/E1h indicates the chip uses extended registers 34h-3Bh to indicate chip revision and features.							

Bits 5-0: VG-PD6729 Revision

This field identifies the revision of the controller.

Bits 7-6: VG-PD6729 PC Card Controller

00	Second read after I/O write to this register.
11	First read after I/O write to this register.

This field identifies a VG-PD6729 device. After chip reset or doing an I/O write to this register, the first read of this register will return a 11b. On the next read, this field will be 00b. This pattern of toggling data on subsequent reads can be used by software to determine presence of a VG-PD6729 in a system or to determine occurrence of a device reset.

10.5 ATA Control

Register Name: ATA Control							Register Per: socket
Index: 26h							Register Compatibility Type: ext.
Bit 7	Bit 6	Bit 5	Bit 4	Bit 3	Bit 2	Bit 1	Bit 0
A25/CSEL	A24/M/S*	A23/VU	A22	A21	Scratchpad Bit	Speaker Is LED Input	ATA Mode
RW:0	RW:0	RW:0	RW:0	RW:0	RW:0	RW:0	RW:0

Bit 0: ATA Mode

0	Normal operation.
1	Configures the socket interface to handle ATA-type disk drives.



This bit reconfigures the particular socket as an ATA drive interface. Refer to [Table 11 on page 91](#) for PCMCIA socket pin definitions in ATA mode.

Bit 1: Speaker Is LED Input

0	Normal operation.
1	The PCMCIA -SPKR pin will be used to drive LED_OUT* if Drive LED Activity Enable (see Extension Control 1” on page 77) is set.

This bit changes the function of the BVD2/-SPKR/-LED pin ([Table 2](#)) from digital speaker input to disk status LED input. When in I/O Card Interface mode or ATA mode, setting this bit to a ‘1’ reconfigures the BVD2/-SPKR/-LED input pin to serve as a -LED input from the socket.

Note: This bit should be set to a ‘0’ if in Memory Card Interface mode.

Bit 3: A21

In ATA mode, the value in this bit is applied to the ATA A21 pin and is vendor-specific. Certain ATA drive vendor-specific performance enhancements beyond the PCMCIA 2.1 standard can be controlled through use of this bit. This bit has no hardware control function when not in ATA mode.

Bit 4: A22

In ATA mode, the value in this bit is applied to the ATA A22 pin and is vendor-specific. Certain ATA drive vendor-specific performance enhancements beyond the PCMCIA 2.1 standard can be controlled through use of this bit. This bit has no hardware control function when not in ATA mode.

Bit 5: A23/VU

In ATA mode, the value in this bit is applied to the ATA A23 pin and is vendor-specific. Certain ATA drive vendor-specific performance enhancements beyond the PCMCIA 2.1 standard can be controlled through use of this bit. This bit has no hardware control function when not in ATA mode.

Bit 6: A24/M/S*

In ATA mode, the value in this bit is applied to the ATA A24 pin and is vendor-specific. Certain ATA drive vendor-specific performance enhancements beyond the PCMCIA 2.1 standard can be controlled through use of this bit. This bit has no hardware control function when not in ATA mode.

Bit 7: A25/CSEL

In ATA mode, the value in this bit is applied to the ATA A25 pin and is vendor-specific. Certain ATA drive vendor-specific performance enhancements beyond the PCMCIA 2.1 standard can be controlled through use of this bit. This bit has no hardware control function when not in ATA mode.



10.6 Extended Index

Register Name: Extended Index						Register Per: socket	
Index: 2Eh						Register Compatibility Type: ext.	
Bit 7	Bit 6	Bit 5	Bit 4	Bit 3	Bit 2	Bit 1	Bit 0
Extended Index							
RW:00000000							

This register controls which of the following registers at index 2Fh can be accessed:

Register Name at Index 2Fh	Extended Index
Scratchpad	00h
Reserved	01h
Reserved	02h
Extension Control 1	03h
Reserved	04h
System Memory Map 0 Upper Address	05h
System Memory Map 1 Upper Address	06h
System Memory Map 2 Upper Address	07h
System Memory Map 3 Upper Address	08h
System Memory Map 4 Upper Address	09h
Reserved	0Ah
Misc. Control 3	25h
Mask Revision Byte	34h
Product ID Byte	35h
Device Capability Byte A	36h
Device Capability Byte B	37h
Device Implementation Byte A	38h
Device Implementation Byte B	39h
Device Implementation Byte C	3Ah
Device Implementation Byte D	3Bh

For information on how to access these registers, see “Host Access to Registers” on page 31.



10.7 Extended Data

Register Name: Extended Data						Register Per: socket	
Index: 2Fh						Register Compatibility Type: ext.	
Bit 7	Bit 6	Bit 5	Bit 4	Bit 3	Bit 2	Bit 1	Bit 0
Extended Data							

The data in this register allows the registers indicated by the **Extended Index** register to be read and written. The value of this register is the value of the register selected by the **Extended Index** register.

10.7.1 Extension Control 1

Register Name: Extension Control 1				Register Per: socket			
Index: 2Fh				Extended Index: 03h		Register Compatibility Type: ext.	
Bit 7	Bit 6	Bit 5	Bit 4	Bit 3	Bit 2	Bit 1	Bit 0
Reserved		Pull-Up Control	Invert Management IRQ Output	Invert Card IRQ Output	LED Activity Enable	Auto Power Clear	V _{CC} Power Lock
RW:00		RW:0	RW:0	RW:0	RW:0	RW:0	RW:0

Bit 0: V_{CC} Power Lock

0	The V _{CC} Power bit (bit 4 of Power Control register) is not locked.
1	The V _{CC} Power bit (bit 4 of Power Control register) cannot be changed by software.

This bit can be used to prevent card drivers from overriding the Socket Services' task of controlling power to the card, thus preventing situations where cards are powered incorrectly.

Bit 1: Auto Power Clear

0	The V _{CC} Power bit (bit 4 of Power Control register) is reset to '0' when the card is removed.
1	The V _{CC} Power bit (bit 4 of Power Control register) is not affected by card removal.

Bit 2: LED Activity Enable

0	LED activity disabled.
1	LED activity enabled.



PCI-to-PC Card (PCMCIA) Host Controller – VG-PD6729

This bit allows the LED_OUT* pin to reflect any activity in the card. Whenever PCMCIA cycles are in process to or from a card in either socket, LED_OUT* will be active low.

Bit 3: Invert Card IRQ Output

0	The card IRQ is active-high.
1	The card IRQ is active-low and open-drain.

This bit changes the active-high, ISA-type card IRQ level to an active-low, open-collector output that complies with PCI bus requirements.

Bit 4: Invert Management IRQ Output

0	The management IRQ is active-high.
1	The management IRQ is active-low and open-drain.

This bit changes the active-high, ISA-type management IRQ level to an active-low, open-collector output that complies with PCI bus requirements.

Table 10. Bit 5: Pull-Up Control

0	Pull-ups on VS2, VS1, CD2, and CD1 are in use.
1	Pull-ups on VS2, VS1, CD2, and CD1 are turned off.

This bit turns off the pull-ups on VS2, VS1, CD2, and CD1. Turning off these pull-ups can be used in addition to Suspend mode to even further reduce power when cards are inserted but no card accessibility is required. Even though power may or may not still be applied, all pull-ups and their associated inputs will be disabled.

Note: Insertion or removal of a card cannot be determined when this bit is set to a '1'. Also, when a card is already in the socket, a card detect interrupt will be generated when this bit is changed from a '0' to '1'.

10.7.2 System Memory Map 0-4 Upper Address

Register Name: System Memory Map 0-4						Register Per: socket	
Upper Address						Register Compatibility Type: ext.	
Index: 2Fh		Extended Index: 05h–09h					
Bit 7	Bit 6	Bit 5	Bit 4	Bit 3	Bit 2	Bit 1	v0
Upper Address							
RW:00000000							



These bits are used in comparing PCI Address bits 31-24 for each memory window (0-4). These bits are used in conjunction with the **System Memory Map 0-4 Start Address** and **System Memory Map 0-4 End Address** registers.

10.7.3 Misc Control 3

Register Name: Misc Control 3							Register Per: socket
Index: 2Fh Extended Index: 25h							Register Compatibility Type: ext.
Bit 7	Bit 6	Bit 5	Bit 4	Bit 3	Bit 2	Bit 1	Bit 0
Multimedia Arm	Multimedia Expand	Reserved					
R/W:0	R/W:0						

Bit 6 — Multimedia Expand

0	Multimedia expand disabled.
1	Multimedia expand enabled.

This bit allows 24-bit video from the PC Card. If the Multimedia Arm bit and Multimedia Enable bit are both set to '1', this bit causes CE2 and D[15:8] to be tristated on the 16-bit PC Card bus, and also tristates A[25:4].

10.7.3.1 Bit 7 — Multimedia Arm

0	Multimedia Arm disabled.
1	Multimedia Arm enabled.

No multimedia operation can take place without first setting this bit to '1'; the bit provides an overriding control mechanism. By setting only bit 0 of index 16h, the Multimedia Arm bit ensures that multimedia operation is not inadvertently set by software or point enablers.

10.8 Device Identification and Implementation Scheme

There are four byte-wide registers with read-only device information, and four byte-wide read/write registers that contain specific system-implementation information. These registers are found in revisions of the VG-PD6729 that have the value 21h/E1h in the Chip Information register (index 1Fh).



10.8.1 Mask Revision Byte

Register Name: Mask Revision Byte							Register Per: chip
Index: 2Fh			Extended Index: 34h		Register Compatibility Type: ext.		
Bit 7	Bit 6	Bit 5	Bit 4	Bit 3	Bit 2	Bit 1	v0
Mask Revision							
R:nnnnnnnn							

Bits 7:0 — Mask Revision

These bits indicate the mask revision of the device.

10.8.2 Product ID Byte

Register Name: Product ID Byte							Register Per: chip
Index: 2Fh			Extended Index: 35h		Register Compatibility Type: ext.		
Bit 15	Bit 14	Bit 13	Bit 12	Bit 11	Bit 10	Bit 9	Bit 8
Family Code				Product Code			
R:0	R:0	R:1	R:0	R:0	R:0	R:0	R:0

Bits 15:12 — Family Code

A value of '2h' indicates the VG-PD6729 family.

Bits 11:8 — Product Code

These bits indicate the product code of the device within its family.

- Product Codes — VG-PD6729 Family (Family Code 2h)

0h	VG-PD6729 PCI/PCMCIA Controller, dual isolated sockets, 208 pin
1h-Fh	Reserved for future use for VG-PD6729 devices



10.8.3 .Device Capability Byte A

Register Name: Device Capability Byte A						Register Per: chip	
Index: 2Fh		Extended Index: 36h				Register Compatibility Type: ext.	
Bit 23	Bit 22	Bit 21	Bit 20	Bit 19	Bit 18	Bit 17	Bit 16
Per Skt LED	RFU	GPSTB Capable	RFU	Slave DMA	IDE Interface	# Sockets 1	# Sockets 0
R:0	R:0	R:1	R:0	R:0	R:0	R:0	R:1

Bit 23: Per-Socket LED

A '0' indicates that the VG-PD6729 uses a single LED output to indicate status on both sockets.

Bit 22: RFU (Reserved for Future Use)

Reserved for future use.

Bit 21: GPSTB Capable

A value of '1' in this field is intended to indicate that the VG-PD6729 device supports general-purpose strobe.

Bit 20: RFU (Reserved for Future Use)

Reserved for future use.

Bit 19: Slave DMA

A '0' at this bit indicates that the VG-PD6729 does not act as an DMA slave.

Bit 18: IDE Interface

A value of '0' indicates that this device does not provide a separate IDE interface. Note that PCMCIA-ATA drives are supported through the PC Card interfaces on the VG-PD6729.

Bit 17:16: Number of Sockets Supportable By Device

This bit field is '0', indicating the VG-PD6729 supports two PC Card sockets.



10.8.4 Device Capability Byte B

Register Name: Device Capability Byte B						Register Per: chip	
Index: 2Fh		Extended Index: 37h				Register Compatibility Type: ext.	
Bit 31 Extended Def'n	Bit 30 RFU (ZV)	Bit 29 RFU (ZV)	Bit 28 RFU (ZV)	Bit 27 RFU (CB)	Bit 26 CLKRUN Support	Bit 25 LOCK# Support	Bit 24 CardBus Capable
R:0	R:0	R:0	R:0	R:0	R:0	R:0	R:0

Bit 31: Extended Definitions

A value of '0' indicates that there is no extended definition. Description of device capabilities and implementations stops at extended register 3Bh.

Bits 30:27: RFU (Reserved for Future Use)

Reserved for future use.

Bit 26: CLKRUN Support

A '0' indicates that the VG-PD6729 does not output a CLKRUN signal for the PCI Mobile Spec signaling for control of system clock turn on/turn off.

Bit 25: LOCK# Support

A '0' indicates that the VG-PD6729 does not support operations involving the LOCK#

Bit 24: Cardbus Capable

A '0' in this bit indicates that the VG-PD6729 does not support Cardbus transfer cycles on PC Cards.

10.8.5 Device Implementation Byte A

Register Name: Device Implementation Byte A						Register Per: chip	
Index: 2Fh		Extended Index: 38h				Register Compatibility Type: ext.	
Bit 39 RI_OUT Wired	Bit 38 H/W Sus.Wired	Bit 37 GPSTB B Wired	Bit 36 GPSTB A Wired	Bit 35 VS1/VS2 Wired	Bit 34 Slv. DMA Wired	Bit 33 Sockets Present 1	Bit 32 Sockets Present 0
R/W:0	R/W:0	R/W:0	R/W:0	R/W:1	R/W:0	R/W:0	R/W:1

All bits of this byte are read/write.

Device reset defaults are specific to each device. It is intended that a BIOS write to this byte before launching socket services would set these bits to reflect which features are supported in the system implementation.



Bit 39: RI_OUT Wired

A '1' indicates that in the system implementation, a pin on the device designated as 'RI_OUT' has been connected to ring indicate circuitry. Socket services must set register 1E bit 7 to a '1', thereby enabling this alternate pin definition as it has been wired.

A value of '1' implies that in the system implementation, the RI_OUT*/IRQ15 pin is not connected to the ISA bus IRQ15 line, but is instead connected to an SMI-type system function designed to wake up a system on modem ring.

Bit 38: Hardware Suspend Wired

A '1' indicates that in the system implementation, a pin on the device designated as a hardware control of suspend for deep power saving has been connected to system circuitry designed for power management. Since the VG-PD6729 has no hardware suspend pin, this bit should remain cleared to '0'.

10.8.6 Device Implementation Byte B

Register Name: Device Implementation							Register Per: chip	
Byte B				Extended Index: 39h				Register Compatibility Type: ext.
Index: 2Fh								
Bit 47	Bit 46	Bit 45	Bit 44	Bit 43	Bit 42	Bit 41	Bit 40	
RFU	RF Rated Sockets	VPP_VCC 1A	VPP 12V Avail	X.V Capable	Y.V Capable	5.0V VCC Capable	3.3V VCC Capable	
R/W:0	R/W:1	R/W:0	R/W:1	R/W:0	R/W:0	R/W:1	R/W:1	

Bit 47: RFU (Reserved for future use)

Reserved for future use.

Bit 46: RF Rated Sockets

A value of '1' indicates that in the system implementation, the sockets in this systems are designed to handle cards that operate at radio frequencies like cellular fax/modem, pagers, etc. A value of '0' indicates that the sockets in these systems are not designed to handle cards that operate at radio frequencies like cellular fax/modem, pagers, etc.

Bit 45: VPP_VCC 1A

A value of '1' indicates that, in this implementation, the socket can deliver 1 A to each socket's VPP and VPP2 pins when the VPP voltage is set to VCC.

Bit 44: VPP 12 V available

A value of '1' indicates that a VPP of 12 V is supported in this system. A value of '0' indicates that a VPP of 12 V is not supported in this system, meaning VPP voltages of 'VCC' and 0V are the only programming voltages available.



Bit 43: X.V capable

A value of ‘1’ indicates that X.X V voltage source is available for the powering of PC cards in this system. A value of ‘0’ indicates that X.X V voltage source is not available for the powering of PC cards in this system.

Bit 42: Y.V capable

A value of ‘1’ indicates that Y.Y V voltage source is available for the powering of PC cards in this system. A value of ‘0’ indicates that Y.Y V voltage source is not available for the powering of PC cards in this system.

Bit 41: 5.0V capable

A value of ‘1’ indicates that 5.0 V voltage source is available for the powering of PC cards in this system. A value of ‘0’ indicates that 5.0 V voltage source is not available in this system, and that the PC card sockets only operate at other available voltages indicated by bits 43:41. Systems that only supported 5 V cards set bit 41 to ‘1’ and clear bits 43, 42, and 40 to ‘0’.

Bit 40: 3.3V capable

A value of ‘1’ indicates that 3.3 V voltage source is available for the powering of PC cards in this system. A value of ‘0’ indicates that 3.3 V voltage source is not available for the powering of PC cards in this system. System designs that support both 3.3 and 5.0 V cards set bits to ‘1’ and clear bits 43 and 42 to ‘0’.

10.8.7 .Device Implementation Byte C

Register Name: Device Implementation					Register Per: chip		
Byte C		Extended Index: 3Ah				Register Compatibility Type: ext.	
Index: 2Fh							
Bit 55	Bit 54	Bit 53	Bit 52	Bit 51	Bit 50	Bit 49	Bit 48
RFU	RFU (ZV)	RFU (ZV)	Port B Wired	ZV Port A Wired	SPKR Wired	Per Skt LED	LED Wired
R/W:0	R/W:0	R/W:0	R/W:0	R/W:0	R/W:1	R/W:0	R/W:0

Bits 55:53 — RFU (Reserved for future use)

Reserved for future use.

Bit 52 — ZV Port B Wired

A value of ‘1’ indicates that in the particular system implementation Socket B is wired for ZV operation. A value of ‘0’ indicates that Socket B is not wired for ZV operation.

Bit 51 — ZV Port A Wired

A value of ‘1’ indicates that in the particular system implementation Socket A is wired for ZV operation. A value of ‘0’ indicates that Socket A is not wired for ZV operation.



Bit 50 — SPKR Wired

A value of ‘1’ indicates that in the particular system implementation a speaker is connected to the SPKR_OUT pin. A value of ‘0’ indicates that a speaker is not connected to the SPKR_OUT pin.

Bit 49 — Per Skt LED

A value of ‘1’ indicates that in the particular system implementation there are separate status LEDs for each socket being controlled by the device. This bit should remain cleared to ‘0’ as the VG-PD6729 supports a single status LED.

Bit 48 — LED Wired

A value of ‘1’ indicates that in the particular system implementation a status LED has been connected to the LED_OUT# pin. A value of ‘0’ indicates that a status LED is not connected in this system implementation.

10.8.8 Device Implementation Byte D

Register Name: Device Implementation				Register Per: chip			
Byte D				Register Compatibility Type: ext.			
Index: 2Fh		Extended Index: 3Bh					
Bit 63	Bit 62	Bit 61	Bit 60	Bit 59	Bit 58	Bit 57	Bit 56
RFU	Clk Opt. Wired	RFU	RFU	RFU	RFU	LOCK# Wired	CLKRUN Wired
R/W:0	R/W:0	R/W:0	R/W:0	R/W:0	R/W:0	R/W:0	R/W:0

10.8.8.1 Bit 63 — RFU (Reserved for future use)

Reserved for future use.

Bit 62 — Clk Opt. Wired

A value of ‘1’ indicates that in the particular system implementation an external clock has been wired to the VG-PD6729 EXT_CLK pin. A value of ‘0’ indicates that an external clock being connected.

Bits 61:58 — RFU (Reserved for future use)

Reserved for future use.

Bit 57 — LOCK# Wired

A value of ‘1’ indicates that the system the system implementation provides a LOCK# signal to a device. Since the VG-PD6729 does not implement LOCK#, this bit should remain cleared to ‘0’.



PCI-to-PC Card (PCMCIA) Host Controller – VG-PD6729

Bit 56 — CLKRUN Wired

A value of '1' indicates that the system implementation wires a CLKRUN signal to a device's CLKRUN pin. supports CLKRUN protocol. Since the VG-PD6729 does not have a CLKRUN pin, this bit should remain cleared to '0'.

10.8.9 External Data (Index 6Fh)

Register Name: External Data				Register Per: chip			
Index: 6Fh				Extended Index: 0Ah			
				Register Compatibility Type: ext.			
Bit 7	Bit 6	Bit 5	Bit 4	Bit 3	Bit 2	Bit 1	Bit 0
Reserved				Socket B VS2 Input	Socket B VS1 Input	Socket A VS2 Input	Socket A VS1 Input
RW:0000				R:0	R:0	R:0	R:0

10.8.9.1 Bits 3-0: Socket A/B VS1/VS2 Input

These bits indicate the values of the four voltage sense pins (two for each socket). These values are used to determine the operating voltage capabilities of an inserted card.



11.0 Timing Registers

The following information about the timing registers is important:

- All timing registers take effect immediately and should only be changed when the FIFO is empty (see “FIFO Control” on page 71).
- Selection of Timer Set 0 or Timer Set 1 register sets is controlled by **I/O Window Control**, bits 3 and 7 (see “Bit 3: Timing Register Select 0” on page 60).

11.1 Setup Timing 0-1

Register Name: Setup Timing 0-1						Register Per: socket	
Index: 3Ah, 3Dh						Register Compatibility Type: 365	
Bit 7	Bit 6	Bit 5	Bit 4	Bit 3	Bit 2	Bit 1	Bit 0
Setup Prescalar Select		Setup Multiplier Value					
RW:00		RW:000001					

There are two separate Setup Timing registers, each with identical fields. These registers are located at the following indexes:

Index	(Socket A) Setup Timing
3Ah	Setup Timing 0
3Dh	Setup Timing 1

The Setup Timing register for each timer set controls how long a PCMCIA cycle’s command (that is, -OE, -WE, -IORD, -IOWR; see Table 2 on page 18) setup time will be, in terms of the number of internal clock cycles.

The overall command setup timing length *S* is programmed by selecting a 2-bit prescaling value (bits 7-6 of this register) representing weights of 1, 16, 256, or 4096, and then selecting a multiplier value (bits 5-0) to which that prescalar is multiplied to produce the overall command setup timing length according to the following formula:

$$S = (N_{pres} \times N_{val}) + 1$$

The value of *S*, representing the number of clock cycles for command setup, is then multiplied by the clock period of the internal clock driving the PC card socket interface to determine the actual command setup time (see “PCMCIA Bus Timing Calculations” on page 101 for further discussion).

Bits 5-0: Setup Multiplier Value

This field indicates an integer value N_{val} from 0 to 63; it is combined with a prescalar value (bits 7-6) to control the length of setup time before a command becomes active.



Bits 7-6: Setup Prescalar Select

00	$N_{pres} = 1$
01	$N_{pres} = 16$
10	$N_{pres} = 256$
11	$N_{pres} = 4096$

This field chooses one of four prescalar values N_{pres} that are combined with the value of the Setup Multiplier Value (bits 5-0) to control the length of setup time before a command becomes active.

11.2 Command Timing 0-1

Register Name: Command Timing 0-1						Register Per: socket	
Index: 3Bh, 3Eh						Register Compatibility Type: 365	
Bit 7	Bit 6	Bit 5	Bit 4	Bit 3	Bit 2	Bit 1	Bit 0
Command Prescalar Select		Command Multiplier Value					
RW:00		RW:000101/010100 ¹					
NOTE:							
1. Timing set 0 (index 3Bh) resets to 5h, providing a 300-ns nominal PC card command width useable for support of '250-ns' PC cards. Timing set 1 (3Eh) resets to 14h, providing a 900 ns nominal PC card command width.							

There are two separate Command Timing registers, each with identical fields. These registers are located at the following indexes:

Index	(Socket A) Command Timing
3Bh	Command Timing 0
3Eh	Command Timing 1

The Command Timing register for each timer set controls how long a PCMCIA cycle's command (that is, -OE, -WE, -IORD, -IOWR; see [Table 2 on page 18](#)) active time will be, in terms of the number of internal clock cycles.

The overall command timing length C is programmed by selecting a 2-bit prescaling value (bits 7-6 of this register) representing weights of 1, 16, 256, or 4096, and then selecting a multiplier value (bits 5-0) to which that prescalar is multiplied to produce the overall command timing length according to the following formula:

$$C = (N_{pres} \times N_{val}) + 1$$

The value of C, representing the number of clock cycles for a command, is then multiplied by the clock period of the internal clock driving the PC card interface to determine the actual command active time (see "[PCMCIA Bus Timing Calculations](#)" on [page 101](#) for further discussion).



11.2.0.1 Bits 5-0: Command Multiplier Value

This field indicates an integer value N_{val} from 0 to 63; it is combined with a prescalar value (bits 7-6) to control the length that a command is active.

Bits 7-6: Command Prescalar Select

00	$N_{pres} = 1$
01	$N_{pres} = 16$
10	$N_{pres} = 256$
11	$N_{pres} = 4096$

This field chooses one of four prescalar values N_{pres} that are combined with the value of the Command Multiplier Value (bits 5-0) to control the length that a command is active.

11.3 Recovery Timing 0-1

Register Name: Recovery Timing 0-1						Register Per: socket	
Index: 3Ch, 3Fh						Register Compatibility Type: 365	
Bit 7	Bit 6	Bit 5	Bit 4	Bit 3	Bit 2	Bit 1	Bit 0
Recovery Prescalar Select		Recovery Multiplier Value					
RW:00		RW:000000					

There are two separate Recover Timing registers, each with identical fields. These registers are located at the following indexes:

Index	(Socket A) Recovery Timing
3Ch	Recovery Timing 0
3Fh	Recovery Timing 1

The Recovery Timing register for each timer set controls how long a PCMCIA cycle's command (that is, -OE, -WE, -IORD, -IOWR; see [Table 2](#)) recovery time will be, in terms of the number of internal clock cycles.

The overall command recovery timing length R is programmed by selecting a 2-bit prescaling value (bits 7-6 of this register) representing weights of 1, 16, 256, or 4096, and then selecting a multiplier value (bits 5-0) to which that prescalar is multiplied to produce the overall command recovery timing length according to the following formula:

$$R = (N_{pres} \times N_{val}) + 1$$

The value of R, representing the number of clock cycles for command recovery, is then multiplied by the clock period of the internal clock driving the PC card interface to determine the actual command recovery time (see "PCMCIA Bus Timing Calculations" on page 101 for further discussion).



Bits 5-0: Recovery Multiplier Value

This field indicates an integer value N_{val} from 0 to 63; it is combined with a prescalar value (bits 7-6) to control the length of recovery time after a command is active.

Bits 7-6: Recovery Prescalar Select

00	$N_{pres} = 1$
01	$N_{pres} = 16$
10	$N_{pres} = 256$
11	$N_{pres} = 4096$

This field chooses one of four prescalar values N_{pres} that are combined with the value of the Recovery Multiplier Value (bits 5-0) to control the length of recovery time after a command is active.



12.0 ATA Mode Operation

The VG-PD6729 card interfaces can be dynamically configured to support a PCMCIA-compatible ATA disk interface (commonly known as ‘IDE’) instead of the standard PCMCIA card interface. Disk drives that can be made mechanically-compatible with PCMCIA card dimensions can thus operate through the socket using the ATA electrical interface.

Configuring a socket to support ATA operation changes the function of certain card socket signals to support the needs of the ATA disk interface. [Table 11 on page 91](#) lists each interface pin and its function when a VG-PD6729 card socket is operating in ATA mode.

All register functions of the VG-PD6729 are available in ATA mode, including socket power control, interface signal disabling, and card window control. No memory operations are allowed in NATA mode.

Table 11. ATA Pin Cross-Reference (Sheet 1 of 2)

PCMCIA Socket Pin Number	PCMCIA Card Interface Function	ATA Interface Function	PCMCIA Socket Pin Number	PCMCIA Card Interface Function	ATA Interface Function
1	Ground	Ground	35	Ground	Ground
2	D3	D3	36	-CD1	-CD1
3	D4	D4	37	D11	D11
4	D5	D5	38	D12	D12
5	D6	D6	39	D13	D13
6	D7	D7	40	D14	D14
7	-CE1	CS0*	41	D15	D15
8	A10	n/c	42	-CE2	CS1*
9	-OE	Always low	43	VS1	VS1
10	A11	n/c	44	-IORD	-IORD
11	A9	CS1*	45	-IOWR	-IOWR
12	A8	n/c	46	A17	n/c
13	A13	n/c	47	A18	n/c
14	A14	n/c	48	A19	n/c
15	-WE	n/c	49	A20	n/c
16	-IREQ	IREQ	50	A21	n/c
17	VCC	VCC	51	VCC	VCC
18	VPP1	n/c	52	VPP2	n/c
19	A16	n/c	53	A22	n/c
20	A15	n/c	54	A23	VU
21	A12	n/c	55	A24	M/S*
22	A7	n/c	56	A25	CSEL
23	A6	n/c	57	VS2	VS2

NOTE:
1. Not supported by the PD6729.



PCI-to-PC Card (PCMCIA) Host Controller – VG-PD6729

Table 11. ATA Pin Cross-Reference (Sheet 2 of 2)

PCMCIA Socket Pin Number	PCMCIA Card Interface Function	ATA Interface Function	PCMCIA Socket Pin Number	PCMCIA Card Interface Function	ATA Interface Function
24	A5	n/c	58	RESET	RESET*
25	A4	n/c	59	-WAIT	IOCHRDY
26	A3	n/c	60	-INPACK	DREQ ¹
27	A2	A2	61	-REG	DACK* ¹
28	A1	A1	62	-SPKR	LED*
29	A0	A0	63	-STSCHG	PDIAG* ¹
30	D0	D0	64	D8	D8
31	D1	D1	65	D9	D9
32	D2	D2	66	D10	D10
33	-IOIS16	-IOIS16	67	-CD2	-CD2
34	Ground	Ground	68	Ground	Ground

NOTE:
1. Not supported by the VG-PD6729.



13.0 Electrical Specifications

13.1 Absolute Maximum Ratings

Description	Absolute Maximum Rating
Ambient temperature under bias	0°C to 70°C
Storage temperature	-65°C to 150°C
Voltage on any pin (with respect to ground)	-0.3 volts to 0.3 volts greater than voltage of the +5V pin, respective to ground
Operating power dissipation	500 mW
Power dissipation during Suspend mode	10 mW
Power supply voltage ¹	7 volts
Injection current (latch up) ¹	25 mA
NOTE: Stresses above those listed may cause permanent damage to system components. These are stress ratings only; functional operation at these or any conditions above those indicated in the operational sections of this specification is not implied. Exposure to absolute maximum rating conditions for extended periods of time may affect system reliability.	

13.2 DC Specifications

Table 12. General DC Specifications

Symbol	Parameter	MIN	MAX	Unit	Conditions
C _{IN}	Input capacitance		10.0	pF	
C _{OUT}	Output capacitance		10.0	pF	
I _{IL}	Input leakage	-10.0	10.0	μA	0 < V _{IN} < respective V _{CC} supply pin
I _{PU}	Internal pull-up current	-30	-400	μA	

Table 13. PCMCIA Bus Interface DC Specifications (Sheet 1 of 2)

Symbol	Parameter	MIN	MAX	Unit	Conditions
SOCKET_VCC _{5V}	Power supply voltage	4.5	5.5	V	Normal operation
SOCKET_VCC _{3V}		3.0	3.6	V	
V _{IH}	Input high voltage	2.0	3.6	V	V _{DD} core voltage = 3.0V, Misc Control 2 register, bit 3 = '0'
		2.0	-400	V	V _{DD} core voltage = 4.5V, Misc Control 2 register, bit 3 = '1'

Table 13. PCMCIA Bus Interface DC Specifications (Sheet 2 of 2)

Symbol	Parameter	MIN	MAX	Unit	Conditions
V _{IL}	Input low voltage		0.8	V	V _{DD} core voltage = 3.6V, Misc Control 2 register, bit 3 = '0'
			0.8	V	V _{DD} core voltage = 5.5V, Misc Control 2 register, bit 3 = '1'
V _{IHC}	Input high voltage CMOS	0.7 V _{DD}		V	V _{DD} core voltage = 3.6V, Misc Control 2 register, bit 3 = '0'
V _{ILC}	Input low voltage CMOS		0.2 V _{DD}	V	V _{DD} core voltage = 5.5V, Misc Control 2 register, bit 3 = '1'
V _{OH}	Output high voltage	2.4		V	At rated I _{OH} , respective SOCKET_VCC = 3.0V
V _{OHC}	Output high voltage CMOS	SOCKET_VCC – 0.5		V	At rated I _{OHC} , respective SOCKET_VCC = 3.0V
V _{OL}	Output low voltage		0.4	V	At rated I _{OL}
I _{OH}	Output high current	-2		mA	Respective SOCKET_VCC = 3.0V V _{OH} = 2.4V
I _{OHC}	Output high current CMOS	-1		mA	Respective SOCKET_VCC = 3.0V V _{OHC} = SOCKET_VCC - 0.5V
I _{OL}	Output low current	2		mA	Respective SOCKET_VCC = 3.0V V _{OL} = 0.4V

Table 14. PCI Bus Interface DC Specifications

Symbol	Parameter	MIN	MAX	Unit	Conditions
PCI_VCC _{5V}	Power supply voltage	4.5	5.5	V	Normal operation
PCI_VCC _{3V}		3.0	3.6	V	
V _{IH} ¹	Input high voltage	2.0		V	V _{DD} core voltage = 3.0V
V _{IL} ¹	Input low voltage		0.8	V	V _{DD} core voltage = 3.6V
V _{IHC} ¹	Input high voltage CMOS	0.7 V _{DD} ²		V	V _{DD} core voltage = 4.5V
V _{ILC} ¹	Input low voltage CMOS		0.2 V _{DD} ²	V	V _{DD} core voltage = 5.5V
V _{OH}	Output high voltage	2.4		V	At rated I _{OH} , PCI_VCC = 3.0V
V _{OHC}	Output high voltage CMOS	PCI_VCC – 0.5		V	At rated I _{OHC} , PCI_VCC = 3.0V
V _{OL}	Output low voltage		0.5	V	At rated I _{OL}
I _{OH}	Output current high	-5		mA	PCI_VCC = 3.0V; V _{OH} = 2.4V
I _{OHC}	Output current high CMOS	-1		mA	PCI_VCC = 3.0V; V _{OHC} = PCI_VCC – 0.5V
I _{OL}	Output current low	16		mA	PCI_VCC = 3.0V; V _{OH} = 2.4V

NOTES:

- When CORE_VDD is 3.3V, input thresholds are TTL-compatible; when CORE_VDD is 5V, input thresholds are CMOS-compatible.
- The value of the input threshold level is dependent on the voltage applied to the CORE_VDD pin of the VG-PD6729.



Table 15. Power Control Interface (+5V Powered) DC Specifications

Symbol	Parameter	MIN	MAX	Unit	Conditions
+5V	+5V supply voltage	Highest V_{CC} -0.3			
V_{IH}	Input high voltage	2.0		V	+5V pin voltage = 4.5V
V_{IL}	Input low voltage		0.8	V	+5V pin voltage = 5.5V
V_{OH}	Output high voltage	2.4		V	+5V pin voltage = 4.5V, $I_{OH} = -5$ mA
V_{OHC}	Output high voltage CMOS	+5V voltage - 0.5		V	+5V pin voltage = 4.5V, $I_{OH} = -1$ mA
V_{OL}	Output low voltage		0.4	V	
I_{OH}	Output current high	-5		mA	Respective +5V pin voltage = 4.5V,, $V_{OH} = 2.4V$
I_{OHC}	Output current high CMOS	-1		mA	Respective +5V pin voltage = 4.5V, $V_{OHC} = +5V$ pin voltage -0.5V
I_{OL}	Output current low	16		mA	Respective +5V pin voltage = 4.5V, $V_{OL} = 0.4V$

Table 16. Operating Current Specifications (3.3V)

Symbol	Parameter	MIN	TYP	MAX	Unit	Conditions
$I_{cc_{tot(1)}}$	Power supply current operating	<6	8	>20	mA	CORE_VDD = 3.3V; +5V, SOCKET_VCC, and PCI_VCC = 5.0V
$I_{cc_{tot(2)}}$	Power supply current, Suspend mode (Misc Control 2, bit 2 = '1')		6		mA	CORE_VDD = 3.3V; +5V, SOCKET_VCC, and PCI_VCC = 5.0V
$I_{cc_{tot(3)}}$	Power supply current, RST# active, no clocks		<250		μ A	CORE_VDD = 3.3V; +5V, SOCKET_VCC, and PCI_VCC = 5.0V

Table 17. Operating Current Specifications (5.0V)

Symbol	Parameter	MIN	TYP	MAX	Unit	Conditions
$I_{cc_{tot(1)}}$	Power supply current, operating	<8	12	>20	mA	CORE_VDD, +5V, SOCKET_VCC, and PCI_VCC = 5.0V
$I_{cc_{tot(2)}}$	Power supply current, Suspend mode (Misc Control 2, bit 2 = '1')		2.5		mA	CORE_VDD, +5V, SOCKET_VCC, and PCI_VCC = 5.0V
$I_{cc_{tot(3)}}$	Power supply current, RST# active, no clocks		<250		μ A	CORE_VDD, +5V, SOCKET_VCC, and PCI_VCC = 5.0V



13.3 AC Timing Specifications

This section includes system timing requirements for the VG-PD6729. Unless otherwise specified, timings are provided in nanoseconds (ns), at TTL input levels, with the ambient temperature varying from 0°C to 70°C, and V_{CC} varying from 3.0V to 3.6V or 4.5V to 5.5V DC. The PCI bus speed is 33 MHz unless otherwise specified. Note the following conventions:

- A pound sign (#) at the end of a pin name indicates an active-low signal for the PCI bus.
- A dash (-) at the beginning of a pin name indicates an active-low signal for the PCMCIA bus.
- An asterisk (*) at the end of a pin name indicates an active-low signal that is a general-interface for the VG-PD6729.

Additionally, the following statements are true for all timing information:

- All timings assume a load of 50 pF.
- TTL signals are measured at TTL threshold; CMOS signals are measured at CMOS threshold.

Table 18. Index of AC Timing Specifications

Title	Page Number
Table 19, "FRAME#, AD[31:0], C/BE[3:0]#, and DEVSEL#"	96
Table 20 "TRDY# and STOP# Delay"	98
Table 22 "IDSEL Timing in a Configuration Cycle"	98
Table 23 "PAR Timing"	99
Table 24 "Pulse Mode Interrupt Timing"	100
Table 25 "Memory Read/Write Timing"	102
Table 26 "Word I/O Read/Write Timing"	103
Table 27 "PCMCIA Read/Write Timing when System is 8-Bit"	104
Table 28 "Normal Byte Read/Write Timing"	105
Table 29 "16-Bit System to 8-Bit I/O Card: Odd Byte Timing"	106

13.3.1 PCI Bus Timing

Table 19. FRAME#, AD[31:0], C/BE[3:0]#, and DEVSEL# (Sheet 1 of 2)

Symbol	Parameter	PCI_VCC = 3.3 V		PCI_VCC = 5.0 V		Units
		MIN	MAX	MIN	MAX	
t ₁	FRAME# setup to PCI_CLK	7	–	7	–	ns
t ₂	AD[31:0] (address) setup to PCI_CLK	7	–	7	–	ns
t ₃	AD[31:0] (address) hold from PCI_CLK	0	–	0	–	ns
t ₄	AD[31:0] (data) setup to PCI_CLK	7	–	7	–	ns
t ₅	AD[31:0] (data) active to HI-Z from PCI_CLK	0	28	0	28	ns
t ₆	C/BE[3:0]# (bus command) setup to PCI_CLK	7	–	7	–	ns
t ₇	C/BE[3:0]# (bus command) hold from PCI_CLK	0	–	0	–	ns



Table 19. FRAME#, AD[31:0], C/BE[3:0]#, and DEVSEL# (Sheet 2 of 2)

Symbol	Parameter	PCI_VCC = 3.3 V		PCI_VCC = 5.0 V		Units
		MIN	MAX	MIN	MAX	
t_8	C/BE[3:0]# (byte enable) setup to PCI_CLK	7	-	7	-	ns
t_9	DEVSEL# delay from PCI_CLK		11		11	
t_{10}	DEVSEL# high before HI-Z	1	-	1	-	PCI_CLK

Figure 13. FRAME#, AD[31:0], C/BE[3:0]#, and DEVSEL# (PCI™ Bus)

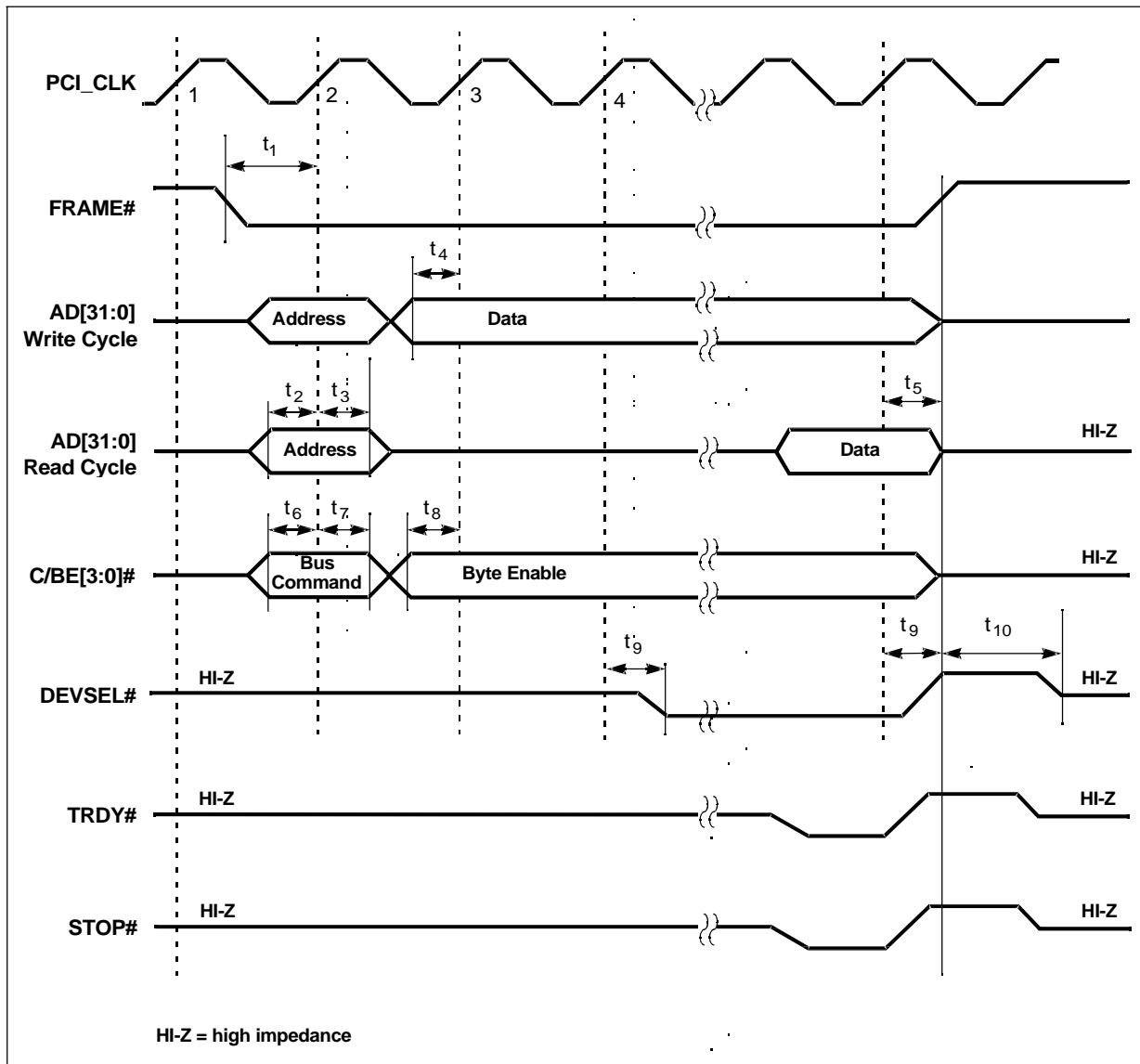



PCI-to-PC Card (PCMCIA) Host Controller – VG-PD6729

Table 20. TRDY# and STOP# Delay

Symbol	Parameter	PCI_VCC = 3.3 V		PCI_VCC = 5.0 V		Units
		MIN	MAX	MIN	MAX	
t ₁	TRDY# active delay from PCI_CLK	-	11	-	11	ns
t ₂	TRDY# inactive delay from PCI_CLK	-	11	-	11	ns
t ₃	TRDY# high before HI-Z	1	-	1	-	PCI_CLK
t ₄	STOP# active delay from PCI_CLK	-	11	-	11	ns
t ₅	STOP# inactive delay from PCI_CLK	-	11	-	11	ns
t ₆	STOP# high before HI-Z	1	-	1	-	PCI_CLK

Table 21. TRDY# and STOP# Delay (PCI™ Bus)

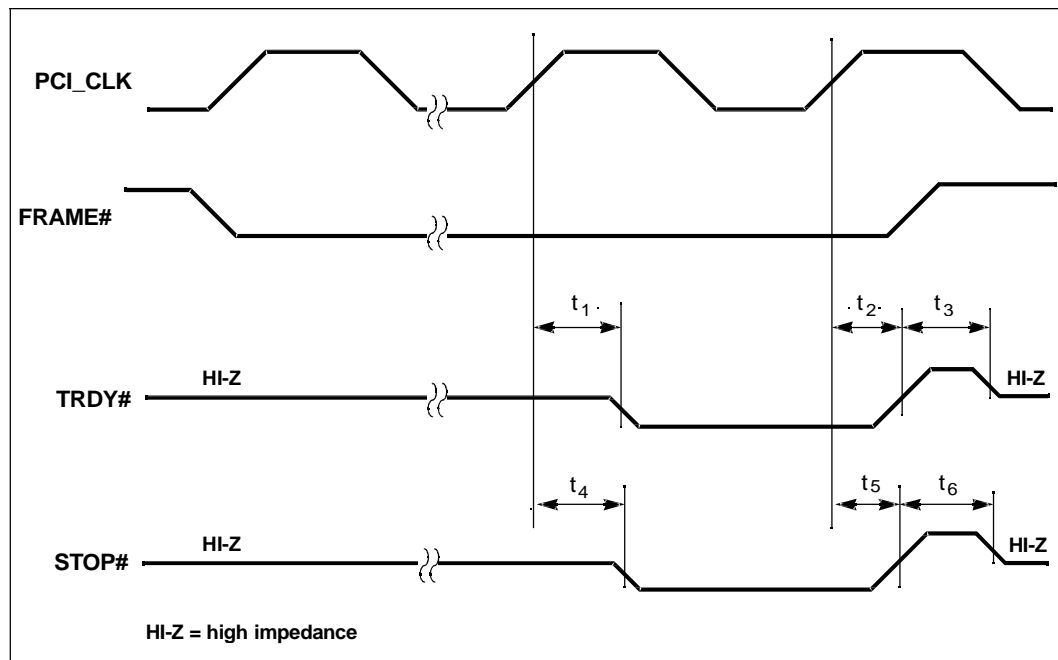

Table 22. IDSEL Timing in a Configuration Cycle

Symbol	Parameter	MIN	MAX	Units
t ₁	IDSEL setup to PCI_CLK	7	-	ns
t ₂	IDSEL hold from PCI_CLK	0	-	ns

Figure 14. IDSEL Timing in a Configuration Cycle (PCI™ Bus)

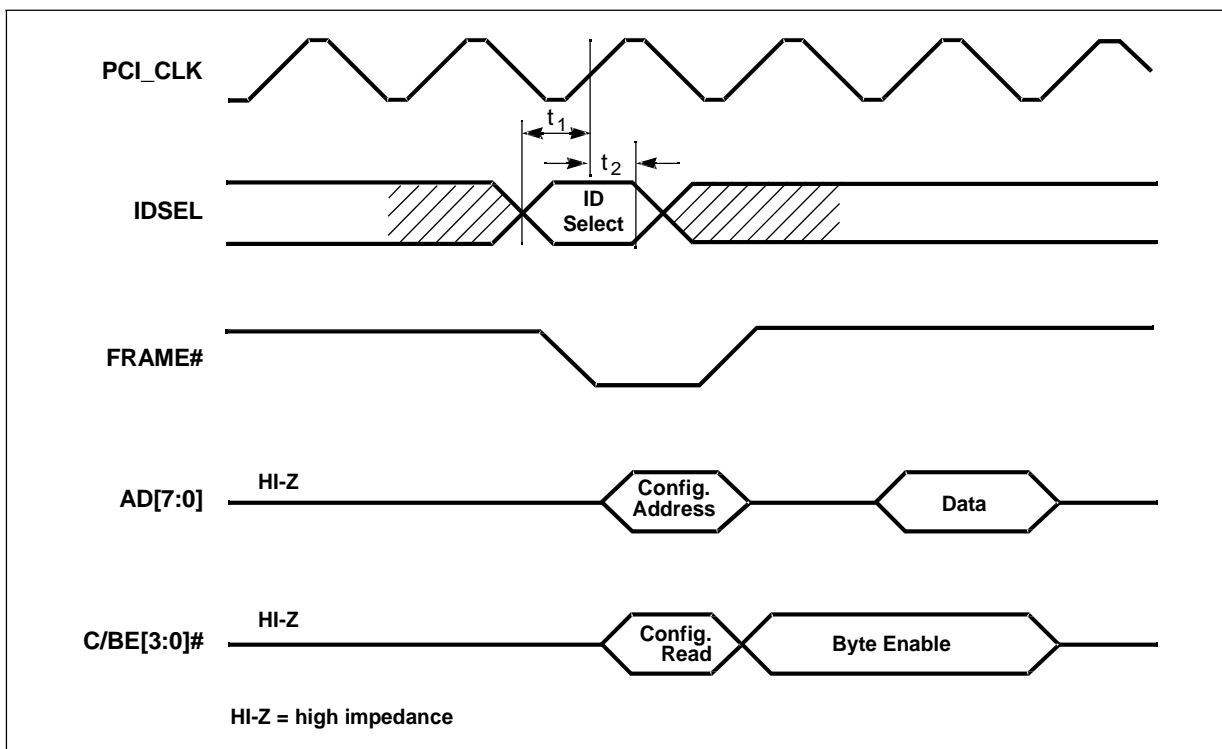
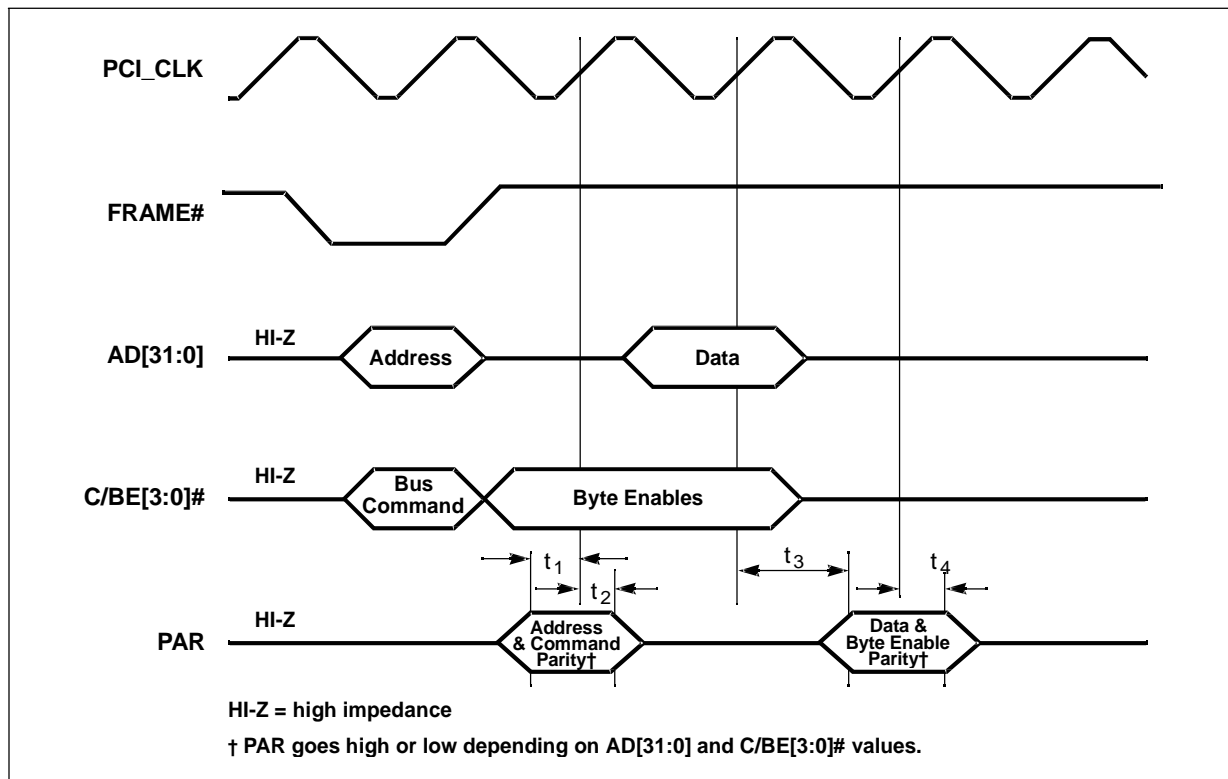

Table 23. PAR Timing

Symbol	Parameter	MIN	MAX	Units
t_1	PAR setup to PCI_CLK (input to VG-PD6729)	7	–	ns
t_2	PAR hold from PCI_CLK (input to VG-PD6729)	0	–	ns
t_3	PAR valid delay from PCI_CLK (output from VG-PD6729)	–	11	ns
t_4	PAR hold from PCI_CLK (output from VG-PD6729)	0	–	ns

Figure 15. PAR Timing (PCI™ Bus)



13.3.2 System Interrupt Timing

Table 24. Pulse Mode Interrupt Timing

Symbol	Parameter	MIN	MAX	Units
t ₁	IRQ[XX] low or high	4	4	PCI_CLK

Figure 16. Pulse Mode Interrupt Timing

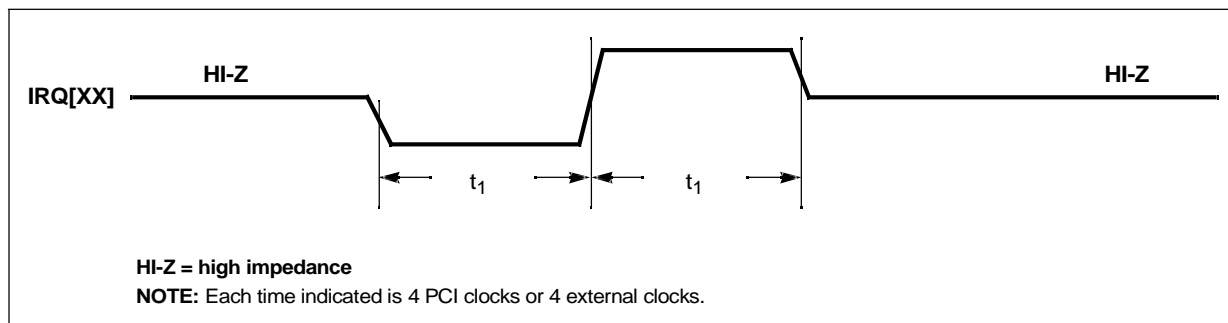



13.3.3 PCMCIA Bus Timing Calculations

Calculations for minimum PCMCIA cycle Setup, Command, and Recovery timings are made by first calculating factors derived from the applicable timer set’s timing registers and then by applying the factor to an equation relating it to the internal clock period.

The PCMCIA cycle timing factors, in terms of the number of internal clocks, are calculated as follows:

$$S = (N_{pres} \times N_{val}) + 1$$

$$C = (N_{pres} \times N_{val}) + 1$$

$$R = (N_{pres} \times N_{val}) + 1$$

N_{pres} and N_{val} are the specific selected prescaler and multiplier value from the timer set’s Setup, Command, and Recovery Timing registers (see “Timing Registers” on page 87 for description of these registers).

From this, a PCMCIA cycle’s Setup, Command, and Recovery time for the selected timer set are calculated as follows:

$$\text{Minimum Setup time} = (S \times T_{cp}) - 20 \text{ ns}$$

$$\text{Minimum Command time} = (C \times T_{cp}) - 20 \text{ ns}$$

$$\text{Minimum Recovery time} = (R \times T_{cp}) - 20 \text{ ns}$$

T_{cp} is two times the period of the PCI bus clock connected to the VG-PD6729 PCI_CLK pin.

If PCI_CLK operates at 33 MHz, then:

$$T_{cp} = 60 \text{ ns}$$

The timing diagrams that follow were derived for a VG-PD6729 using the PCI clock at 33 MHz. The examples are for the default values of the Timing registers for Timer Set 0, as follows:

Timing Register Name (Timer Set 0)	Index	Value (Default)	Resultant N	Resultant N_{val}
Setup Timing 0	3Ah	01h	1	1
Command Timing 0	3Bh	05h	1	5
Recovery Timing 0	3Ch	00h	1	0

Thus the minimum times for the default values are as follows:

$$\text{Minimum Setup time} = (S \times T_{cp}) - 20 \text{ ns} = \{[(1 \times 1) + 1] \times 60 \text{ ns}\} - 20 \text{ ns} = \mathbf{100 \text{ ns}}$$

$$\text{Minimum Command time} = (C \times T_{cp}) - 20 \text{ ns} = \{[(1 \times 5) + 1] \times 60 \text{ ns}\} - 20 \text{ ns} = \mathbf{340 \text{ ns}}$$

$$\text{Minimum Recovery time} = (R \times T_{cp}) - 20 \text{ ns} = \{[(1 \times 0) + 1] \times 60 \text{ ns}\} - 20 \text{ ns} = \mathbf{30 \text{ ns}}$$

13.3.4 PCMCIA Bus Timing

Table 25. Memory Read/Write Timing

Symbol	Parameter	MIN	MAX	Units
t_1	-REG, -CE[2:1], Address, and Write Data setup to Command active ¹	$(S \times T_{cp}) - 20$	-	ns
t_2	Command pulse width ²	$(C \times T_{cp}) - 20$	-	ns
t_3	Address hold and Write Data valid from Command inactive ³	$(R \times T_{cp}) - 30$	-	ns
t_4	-WAIT active from Command active	-	$(C - 2)T_{cp} - 30$	ns
t_5	Command hold from -WAIT inactive	$2 T_{cp}$	-	ns
t_6	Data setup before -OE inactive	$(2 T_{cp}) + 20$	-	ns
t_7	Data hold after -OE inactive	0	-	ns
t_8	Data valid from -WAIT inactive	-	$T_{cp} + 2$	ns

NOTES:

1. The Setup time is determined by the value programmed into the **Setup Timing** register, index 3Ah/3Dh. Using the Timer Set 0 default value of 01h, the setup time would be 100 ns. $S = (N_{pres} \times N_{val} + 1)$, see "PCMCIA Bus Timing Calculations" on page 101.
2. The Command time is determined by the value programmed into the **Command Timing** register, index 3Bh/3Eh. Using the Timer Set 0 default value of 05h, the Command time would be 340 ns. $C = (N_{pres} \times N_{val} + 1)$, see page 101.
3. The Recovery time is determined by the value programmed into the **Recovery Timing** register, index 3Ch/3Fh. Using the Timer Set 0 default value of 00h, the hold (Recovery) time would be 30 ns. $R = (N_{pres} \times N_{val} + 1)$, see page 101.

Figure 17. Memory Read/Write Timing

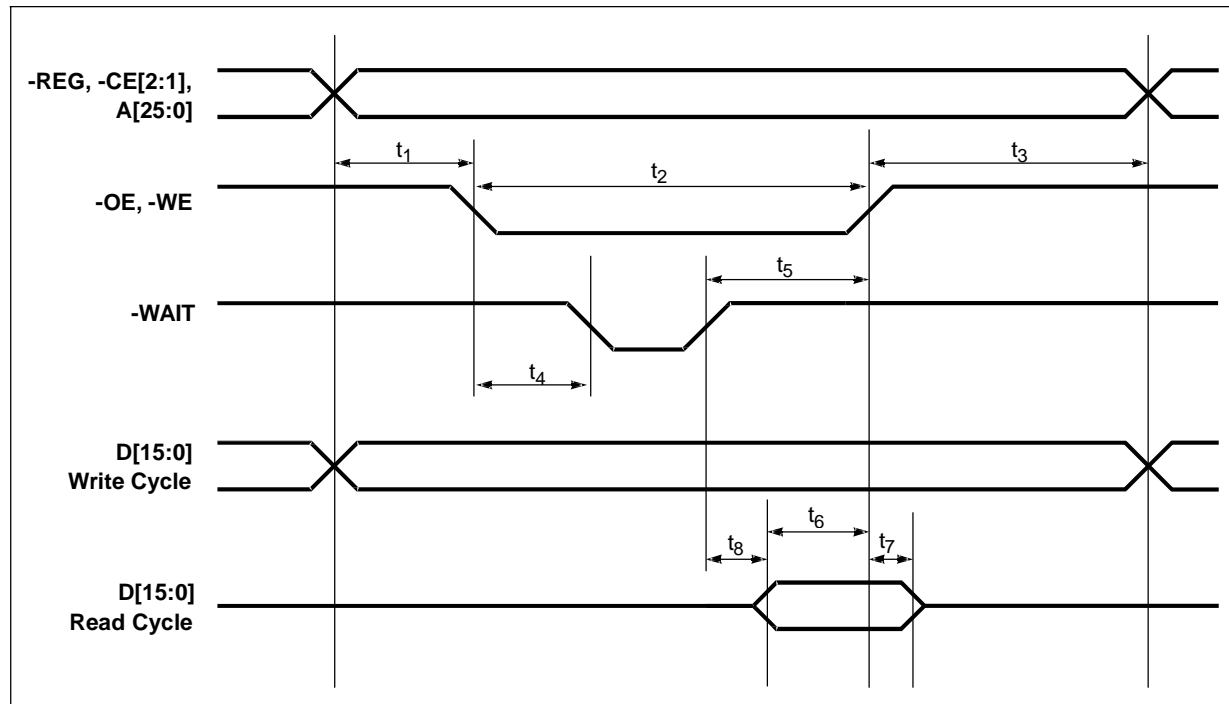



Table 26. Word I/O Read/Write Timing

Symbol	Parameter	MIN	MAX	Units
t ₁	-REG or Address setup to Command active ¹	(S × Tcp) – 20		ns
t ₂	Command pulse width ²	(C × Tcp) – 20		ns
t ₃	Address hold and Write Data valid from Command inactive ³	(R × Tcp) – 20		ns
t ₄	-WAIT active from Command active ⁴		(C – 2) Tcp – 30	ns
t ₅	Command hold from -WAIT inactive	(2 Tcp) + 20		
t _{ref}	Card -IOIS16 delay from valid Address (PCMCIA card specification)		35	ns
t ₆	-IOIS16 setup time before Command end	(3 Tcp) + 20		ns
t ₇	-CE2 delay from -IOIS16 active ⁴	Tcp – 20		ns
t ₈	Data valid from -WAIT inactive		Tcp + 20	ns
t ₉	Data setup before -IORD inactive	(2 Tcp) + 20		ns
t ₇	Data hold after -IORD inactive	0		ns

NOTES:

1. The Setup time is determined by the value programmed into the **Setup Timing** register, index 3Ah/3Dh. Using the Timer Set 0 default value of 01h, the setup time would be 100 ns. $S = (N_{pres} \times N_{val} + 1)$, see [“PCMCIA Bus Timing Calculations” on page 101](#).
2. The Command time is determined by the value programmed into the **Command Timing** register, index 3Bh/3Eh. Using the Timer Set 0 default value of 05h, the Command time would be 340 ns. $C = (N_{pres} \times N_{val} + 1)$, see page 101.
3. The Recovery time is determined by the value programmed into the **Recovery Timing** register, index 3Ch/3Fh. Using the Timer Set 0 default value of 00h, the hold (Recovery) time would be 30 ns. $R = (N_{pres} \times N_{val} + 1)$, see page 101.
4. For typical active timing programmed at 340 ns, maximum -WAIT timing is 200 ns after Command active.
5. -IOIS16 must go low within 3Tcp + 20 ns of the cycle beginning or -IOIS16 will be ignored and -CE will not be activated.

Figure 18. Word I/O Read/Write Timing

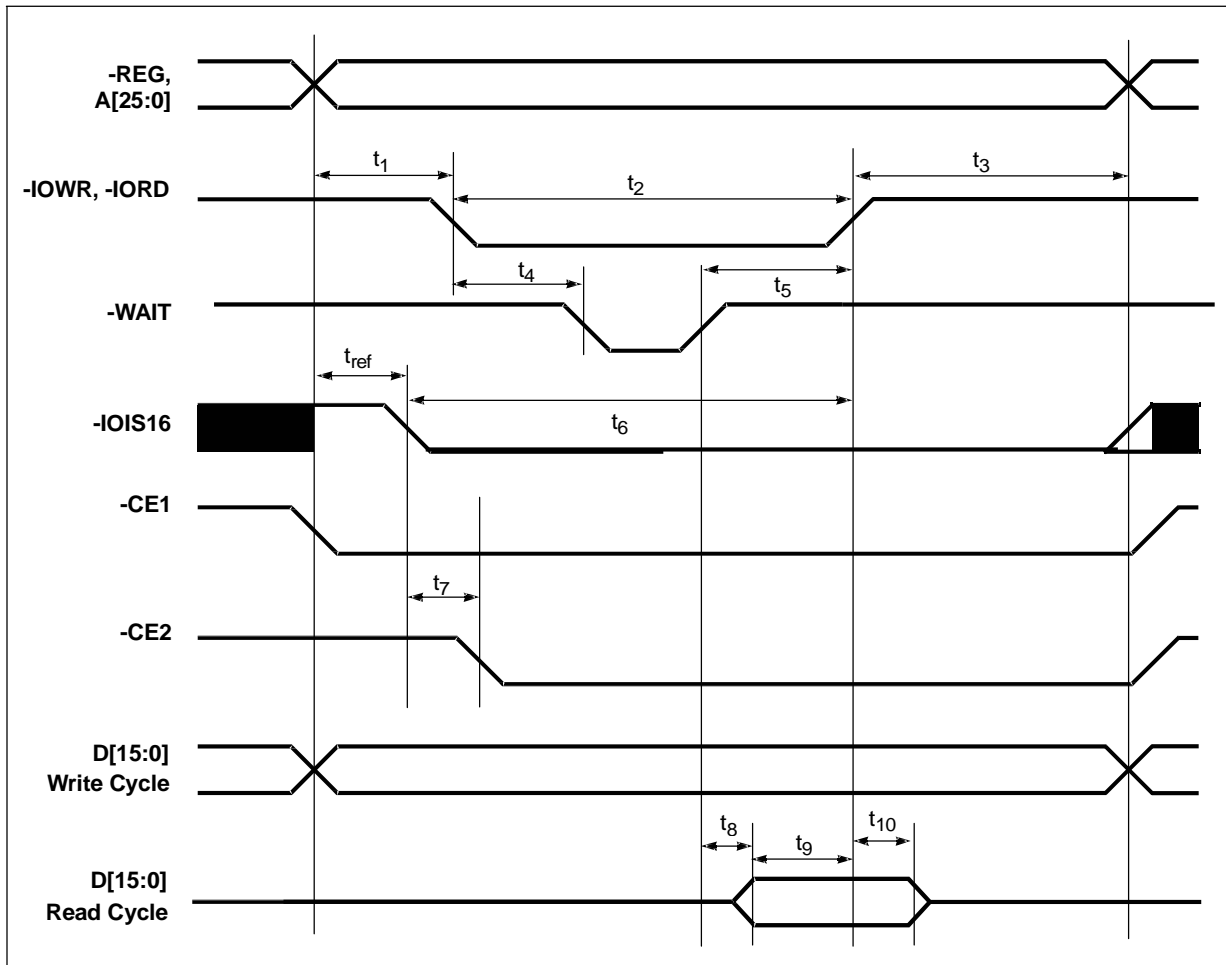

Table 27. PCMCIA Read/Write Timing when System is 8-Bit

Symbol	Parameter	MIN	MAX	Units
t ₁	-REG or Address setup to Command active ¹	(S × T _{cp}) – 10	-	ns
t ₂	Command pulse width ²	(C × T _{cp}) – 10	-	ns
t ₃	Address hold from Command inactive ³	(R × T _{cp}) – 10	-	ns
t ₄	Data setup before Command inactive	(2 T _{cp}) + 10	-	ns
t ₅	Data hold after command inactive	0	-	ns

NOTES:

1. The Setup time is determined by the value programmed into the **Setup Timing** register, index 3Ah/3Dh. Using the Timer Set0 default value of 01h, the setup time would be 100 ns. S = (N_{pres} × N_{val} + 1), see “PCMCIA Bus Timing Calculations” on page 101.
2. The Command time is determined by the value programmed into the **Command Timing** register, index 3Bh/3Eh. Using the Timer Set 0 default value of 05h, the Command time would be 340 ns. C = (N_{pres} × N_{val} + 1), see page 101.
3. The Recovery time is determined by the value programmed into the **Recovery Timing** register, index 3Ch/3Fh. Using the Timer Set 0 default value of 00h, the hold (Recovery) time would be 30 ns. R = (N_{pres} × N_{val} + 1), see page 101.

Figure 19. PCMCIA Read/Write Timing when System is 8 Bit (SBHE Tied High)

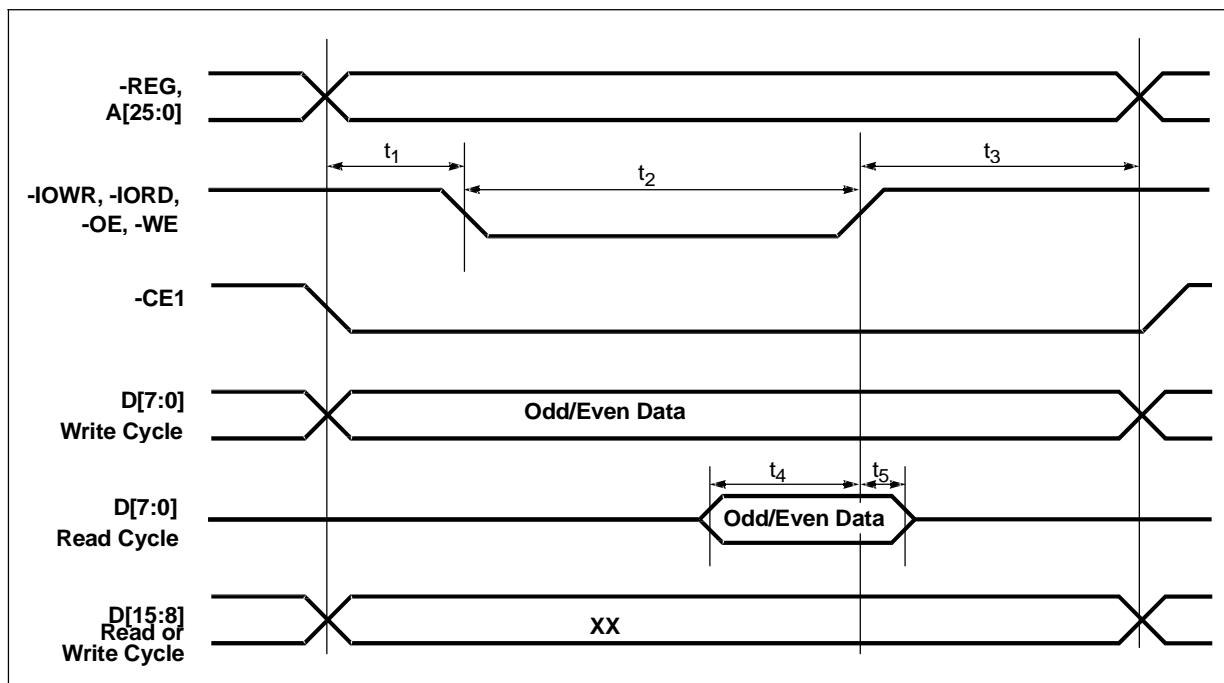

Table 28. Normal Byte Read/Write Timing

Symbol	Parameter	MIN	MAX	Units
t ₁	Address setup to Command active ¹	(S × Tcp) – 20	-	ns
t ₂	Command pulse width ²	(C × Tcp) – 20	-	ns
t ₃	Address hold from Command inactive ³	(R × Tcp) – 20	-	ns

NOTES:

- The Setup time is determined by the value programmed into the **Setup Timing** register, index 3Ah/3Dh. Using the Timer Set 0 default value of 01h, the setup time would be 100 ns. $S = (N_{pres} \times N_{val} + 1)$, see “PCMCIA Bus Timing Calculations” on page 101.
- The Command time is determined by the value programmed into the **Command Timing** register, index 3Bh/3Eh. Using the Timer Set 0 default value of 05h, the Command time would be 340 ns. $C = (N_{pres} \times N_{val} + 1)$, see page 101.
- The Recovery time is determined by the value programmed into the **Recovery Timing** register, index 3Ch/3Fh. Using the Timer Set 0 default value of 00h, the hold (Recovery) time would be 30 ns. $R = (N_{pres} \times N_{val} + 1)$, see page 101.

Figure 20. Normal Byte Read/Write Timing (that is, all other byte accesses, including odd I/O cycles where -IOIS16 is low)

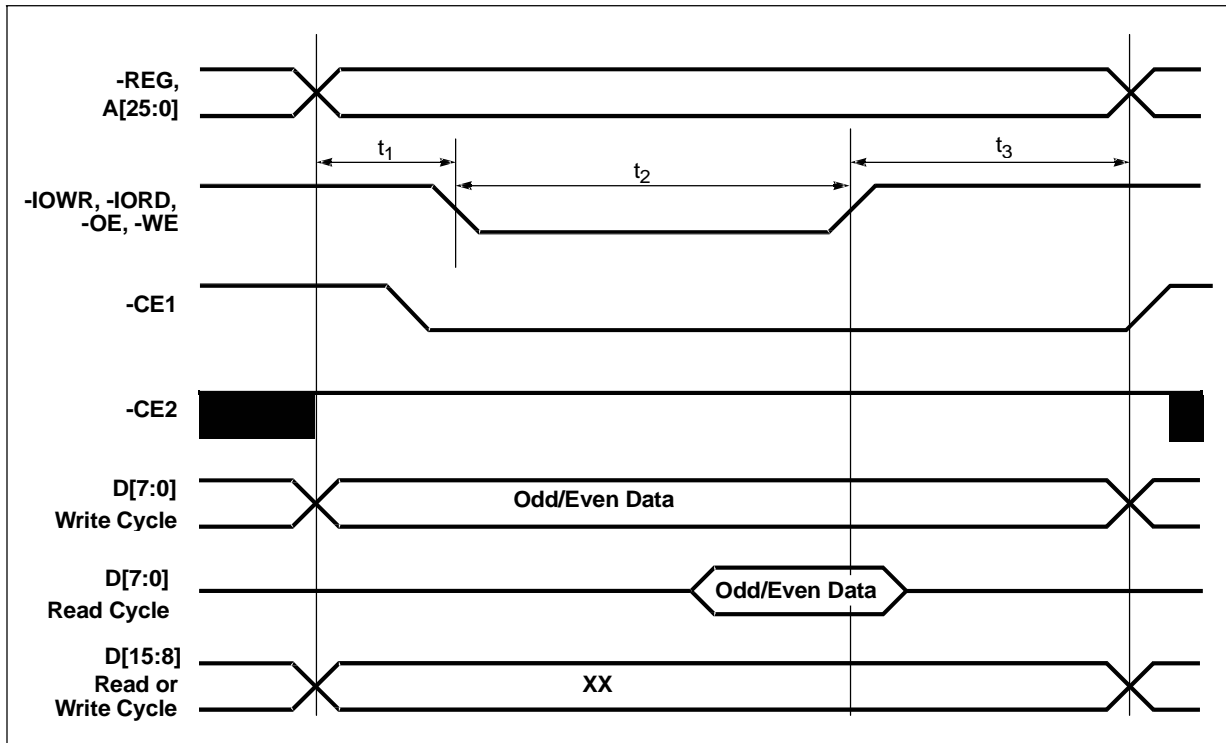

Table 29. 16-Bit System to 8-Bit I/O Card: Odd Byte Timing

Symbol	Parameter	MIN	MAX	Units
t_1	Address change to -IOIS16 inactive ⁴		$(3T_{cp}) + 20$	ns
t_2	-IOIS16 inactive to -CE2 inactive		20	ns
t_3	-IOIS16 inactive to -CE1 active		20	ns
t_4	Address setup to Command active ¹	$(S \times T_{cp}) - 20$		ns
t_5	Command pulse width ²	$(C \times T_{cp}) - 20$		ns
t_6	Address hold from Command inactive ³	$(R \times T_{cp}) - 20$		ns

NOTES:

1. The Setup time is determined by the value programmed into the **Setup Timing** register, index 3Ah/3Dh. Using the Timer Set 0 default value of 01h, the setup time would be 100 ns. $S = (N_{pres} \times N_{val} + 1)$, see "PCMCIA Bus Timing Calculations" on page 101.
2. The Command time is determined by the value programmed into the **Command Timing** register, index 3Bh/3Eh. Using the Timer Set 0 default value of 05h, the Command time would be 340 ns. $C = (N_{pres} \times N_{val} + 1)$, see page 101.
3. The Recovery time is determined by the value programmed into the **Recovery Timing** register, index 3Ch/3Fh. Using the Timer Set 0 default value of 00h, the hold (Recovery) time would be 30 ns. $R = (N_{pres} \times N_{val} + 1)$, see page 101.
4. -IOIS16 level from card must be valid within 3 clocks of an address change to the card.

Figure 21. 16-Bit System to 8-Bit I/O Card: Odd Byte Timing

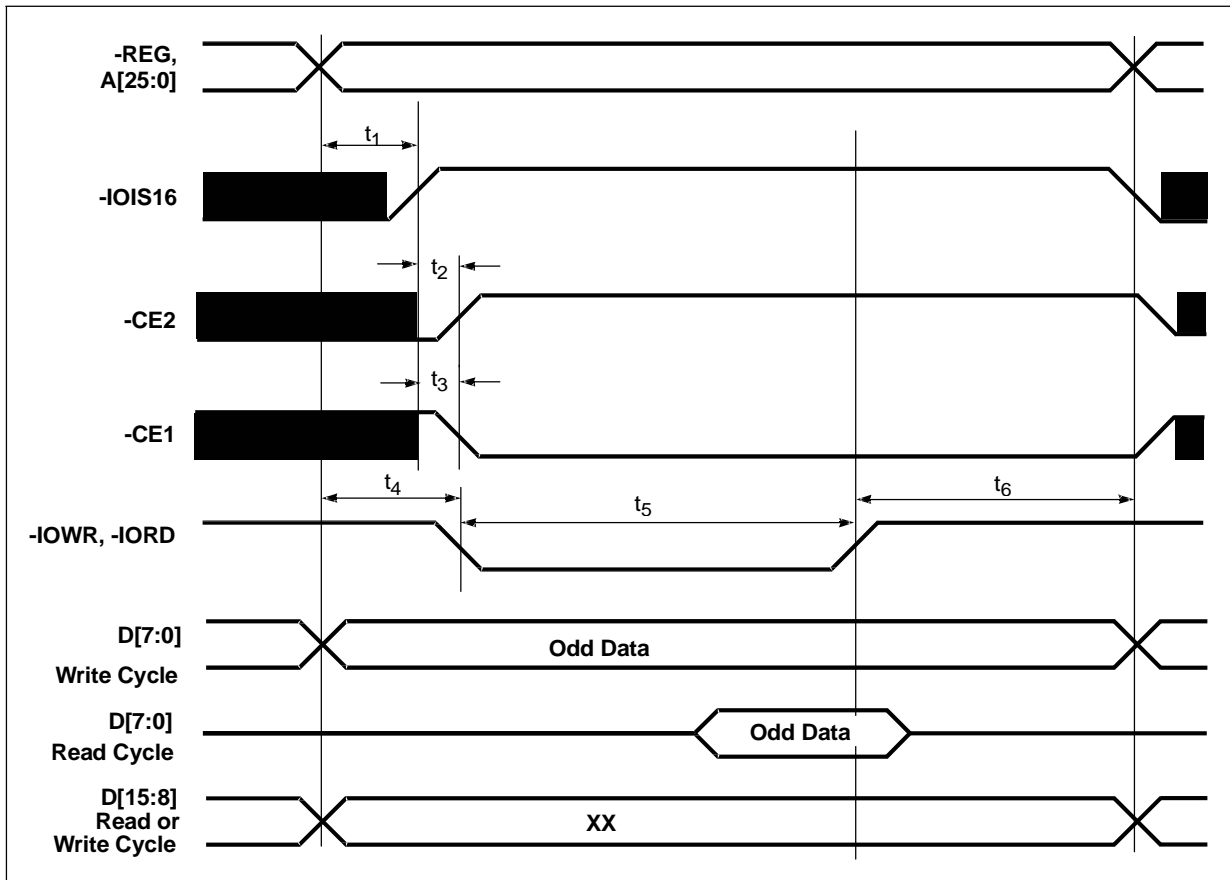



14.0 Package Dimensions

14.1 208-Pin MQFP Package Outline Drawing

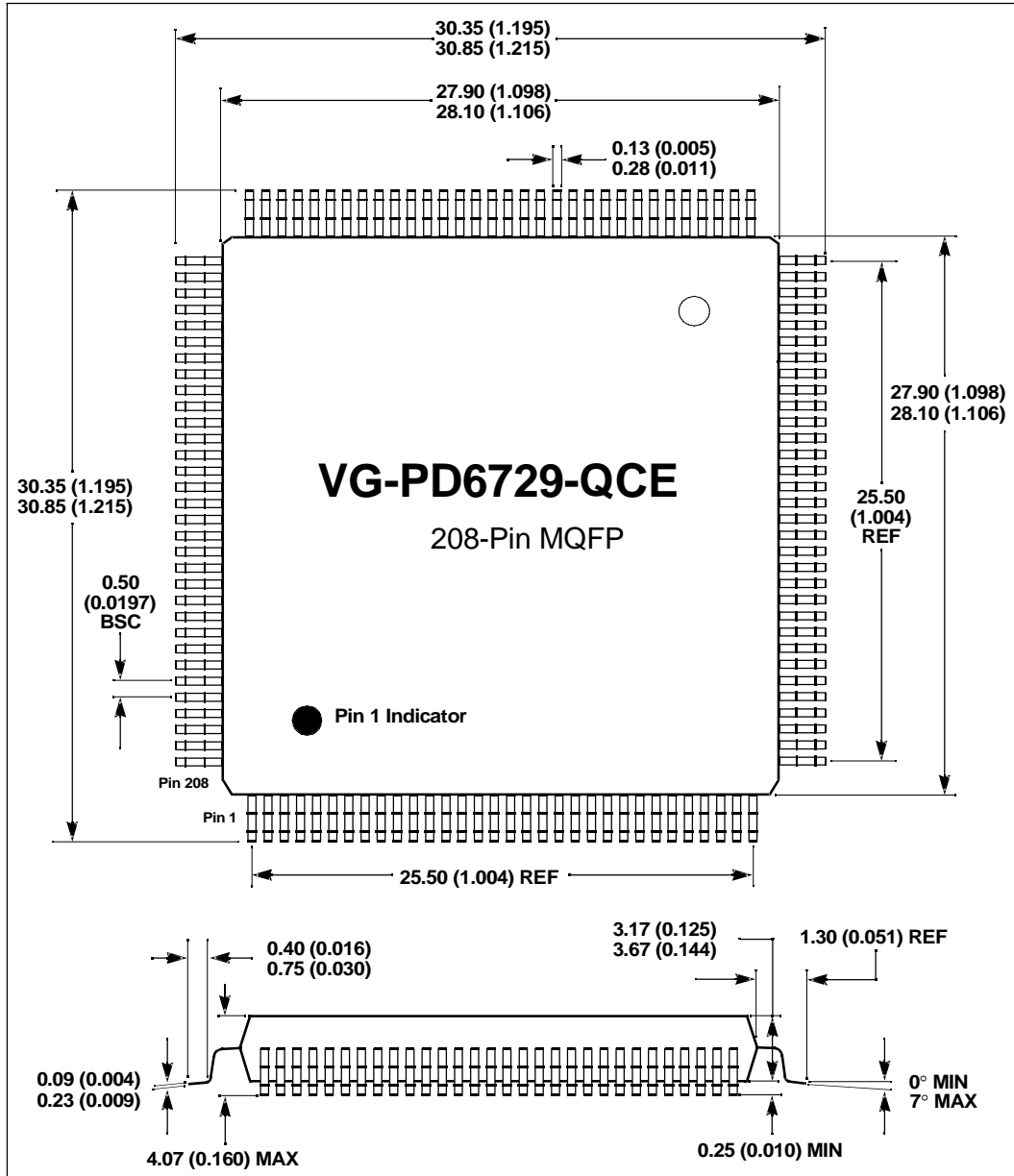

NOTES:

1. Dimensions are in millimeters (inches), and the controlling dimension is millimeter.
2. Drawing above does not reflect exact package pin count.
3. Before beginning any new design with this device, please contact Amplus for the latest package

14.2 208-Pin LQFP Package Outline Drawing

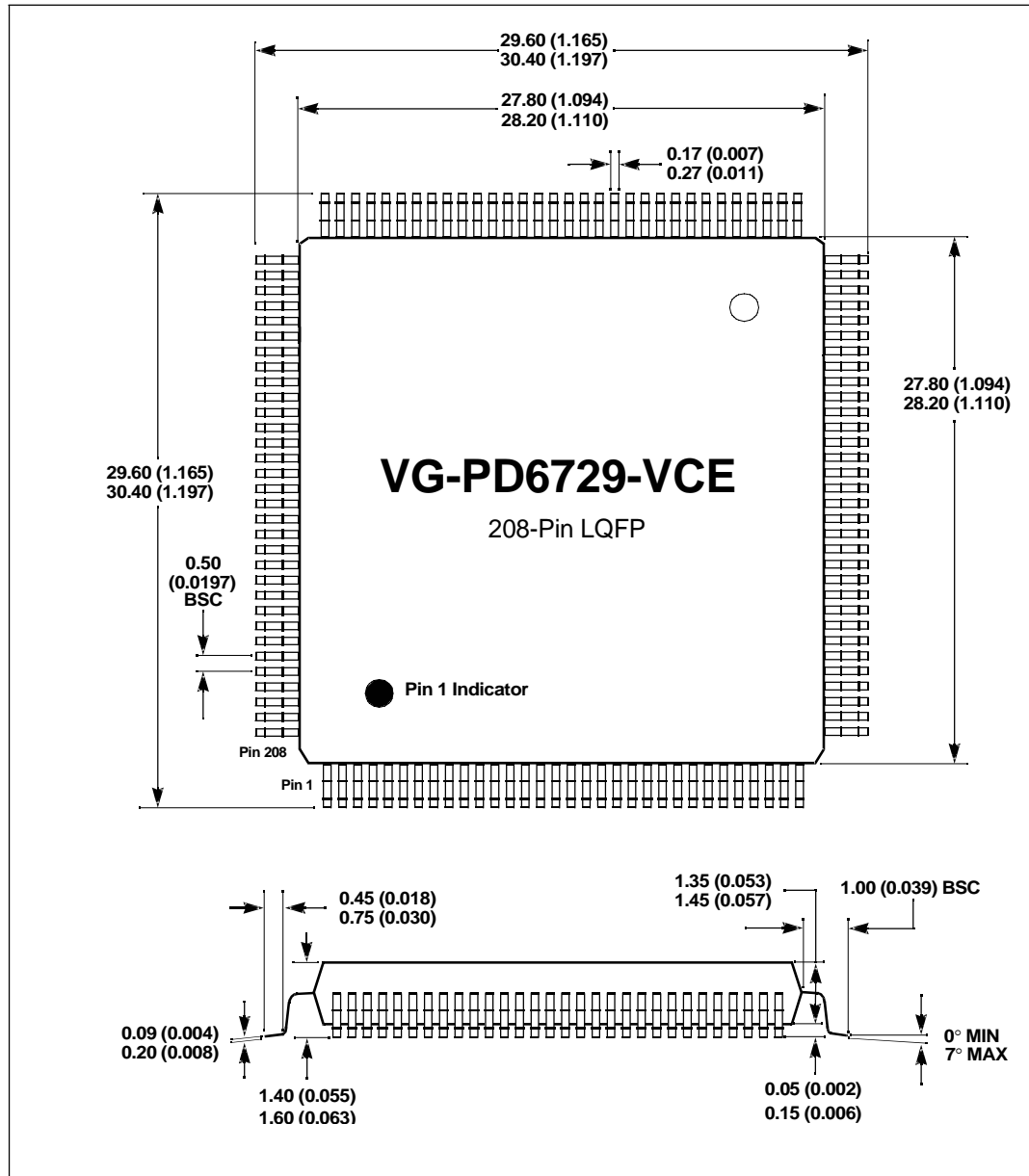

NOTES:

1. Dimensions are in millimeters (inches), and controlling dimension is millimeter.
2. Drawing above does not reflect exact package pin count.
3. Before beginning any new design with this device, please contact Amphus for the latest package

15.0 Ordering Information

The order number for the part is:

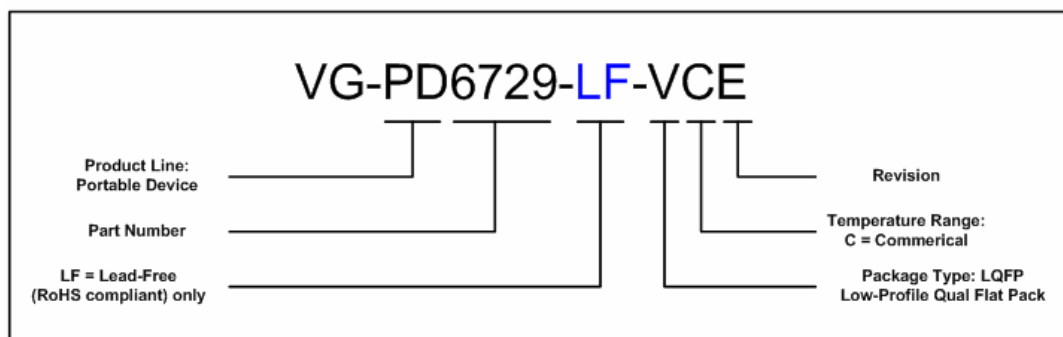
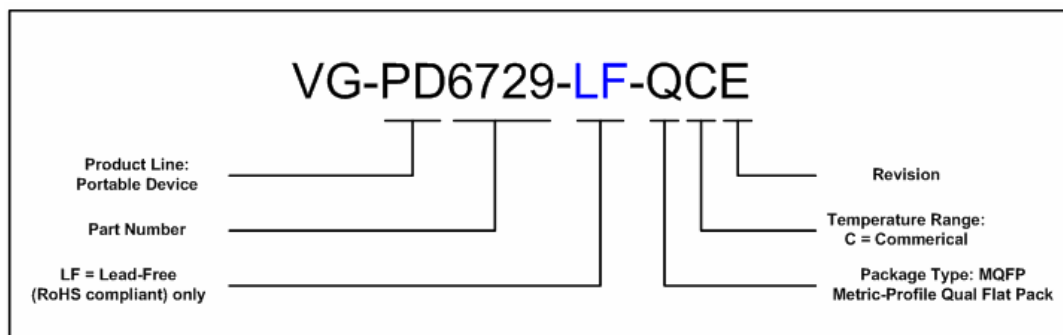

Leaded and lead-free (RoHS compliant) versions are both available.

Ordering Part Numbers:

Leaded version:

- VG-PD6729-QCE (MQFP);
- VG-PD6729-VCE (LQFP);

Lead-Free version (RoHS compliant):

- VG-PD6729-LF-QCE (MQFP);
- VG-PD6729-LF-VCE (LQFP).



Bit Index

Symbols

+5V 21

Numerics

5V Core bit 73

A

A[25:0] 18

A_pin name 18

A21 bit 75

A22 bit 75

A23/VU bit 75

A24/M/S* bit 75

A25/CSEL bit 75

AC specifications 96–107

AD[31:0] 15

Address/Data Parity Error Detected bit 38

ATA Control register 74

ATA mode

 operation of 31, 91

 pin cross reference 91

ATA Mode bit 74

Auto Power Clear bit 77

Auto-Power bit 52

Auto-Size I/O Window 0 bit 60

Auto-Size I/O Window 1 bit 61

B

B_pin name 18

Base Address 0 register 41

Battery Dead Or Status Change bit 54

Battery Dead Or Status Change Enable bit 56

Battery Voltage Detect bits 49

Battery Warning Change bit 55

Battery Warning Enable bit 56

bus sizing 31

BVD1/-STSCHG/-RI 19

BVD2/-SPKR/-LED 19

C

C/BE[3:0]# 15

Cache Line Size, Latency Timer, Header Type, and BIST register 40

Card Detect bits 49

Card Detect Change bit 55

Card Detect Enable bit 56

Card Enable bit 52

Card I/O Map 0-1 Offset Address High registers 64

Card I/O Map 0-1 Offset Address Low registers 64

Card Is I/O bit 53

Card Memory Map 0-4 Offset Address High registers 69

Card Memory Map 0-4 Offset Address Low registers 68

Card Power On bit 50

Card Reset* bit 54

Card Status Change register 54

Card Timer Select bits 68

-CD[2:1] 19

-CE[2:1] 19

Chip Information register 74

Chip Revision register 48

Class Code bits 39

Command and Status register 37

Command Multiplier Value bits 89

Command Prescalar Select bits 89

Command Timing 0-1 registers 88

conventions

 bit descriptions 35

 general 11

 numbers and units 11

 pin naming 13

 register headings 34



CORE_GND 21
CORE_VDD 21

D

D[15:0] 18
Data register 47
DC specifications 93–95
Device Control registers 48–59
Device ID bits 36
DEVSEL# 16
DEVSEL# Timing bits 38

E

End Address 15-8 bits 63
End Address 19-12 bits 67
End Address 23-20 bits 68
End Address 7-0 bits 63
EXT_CLK 16
Extended Data register 77
Extended Index bits 76
Extended Index register 76
Extension Control 1 register 77
Extension registers 70–??
External Clock Enable bit 72

F

FIFO Control register 71
FIFO Status / Flush FIFO bit 72
form factor 1, 108
FRAME# 15

G

general interface pins 20
GPSTB1 20
GPSTB2 20
ground pins 21

H

Header Type bits 40
host access to registers 31

I/O Base Address bits 41
I/O Map 0 Enable bit 58
I/O Map 1 Enable bit 59
I/O Space Indicator bit 41
I/O Window 0 Size bit 60
I/O Window 1 Size bit 61
I/O Window Control register 60
I/O Window Mapping registers 60–64
IDE 91
IDSEL 16
Index register 43
-INPACK 18
Inpack Enable bit 71
INTA# 17
INTB# 17
INTC# 17
INTD# 17
Interface ID bits 48
Interface Status register 49
Interrupt and General Control register 52
Interrupt Line bits 42
Interrupt Line, Interrupt Pin, Min_Gnt, and Max_Lat register 42
Interrupt Pin bits 42
interrupts 27
Inverted Card IRQ Output bit 78
Inverted Management IRQ Output bit 78
-IOIS16 18
-IORD 18
-IOWR 18
-IREQ 19
IRQ Level bits 53
IRQ[12:9] 17
IRQ14/EXT_CLK 16
IRQ15/RI_OUT* 16
IRQ15/RI_OUT* Is RI Out bit 73
IRQ3/INTA# 17
IRQ4/INTB# 17
IRQ5/INTC# 17
IRQ7/INTD# 17



L

- LED 19
- LED Activity Enable bit 77, 79
- LED_OUT* 21
- Low-Power Dynamic Mode bit 73
- Low-power Dynamic mode, description 29

M

- Manage Int Enable bit 53
- Management Interrupt Configuration register 55
- Management IRQ bits 57
- Mapping Enable register 57
- Master Data Parity Error Reported bit 38
- Max_Lat bits 42
- Memory Map 0 Enable bit 57
- Memory Map 1 Enable bit 58
- Memory Map 2 Enable bit 58
- Memory Map 3 Enable bit 58
- Memory Map 4 Enable bit 58
- Memory Window Mapping registers 65–69
- Misc Control 1 register 70
- Misc Control 2 register 72, 79

N

- NC 21
- no-connect pins 21

O

- OE 18
- Offset Address 15-8 bits 64
- Offset Address 19-12 bits 68
- Offset Address 25-20 bits 69
- Offset Address 7-1 bits 64
- Operation registers 43–47

P

- package 108
- PAR 16
- Parity Error Check/Report Enable bit 38
- PCI bus interface pins 15–17
- PCI I/O Space Enable bit 37
- PCI Memory Space Enable bit 37

- PCI_CLK 16
- PCI_VCC 17
- PCI-Configuration registers 36–42
- PCMCIA basics 23
- VG-PD6729 Revision Level bits 74
- PERR# 16
- pin diagram 13
- power control pins 20
- Power Control register 50
- power management
 - device 29
 - socket 30
- power pins 21
- power-on setup 33
- Pull-Up Control bit 78
- Pulse Management Interrupt bit 70
- Pulse System IRQ bit 71

R

- RDY/-IREQ 19
- Ready Change bit 55
- Ready Enable bit 56
- Ready/Busy* bit 50
- Recovery Multiplier Value bits 90
- Recovery Prescalar Select bits 90
- Recovery Timing 0-1 registers 89
- REG 18
- REG Setting bit 69
- Register Index bits 43
- RESET 19
- revision 110
- Revision bits 48
- Revision ID and Class Code register 39
- Revision ID bits 39
- RI 19
- RI_OUT* 16
- Ring Indicate Enable bit 54
- RING_GND 21
- RST# 16

S

- SERR# 16



Setup Multiplier Value bits 87
Setup Prescalar Select bits 88
Setup Timing 0-1 registers 87
socket
 accessing specific registers 44
 interface pins 18–20
 register per 34
Socket A/B VS1/VS2 Input bits 86
Socket Index bit 43
SOCKET_VCC 20
Speaker Enable bit 71
Speaker Is LED Input bit 75
-SPKR 19
SPKR_OUT* 21
Start Address 15-8 bits 62
Start Address 19-12 bits 66
Start Address 23-20 bits 66
Start Address 7-0 bits 62
STOP# 16
-STSCHG 19
Suspend Mode bit 73
Suspend mode, description 29
System Error (SERR#) Enable bit 38
System Error (SERR#) Generated bit 38
System I/O Map 0-1 End Address High registers 63
System I/O Map 0-1 End Address Low registers 62
System I/O Map 0-1 Start Address High registers 62
System I/O Map 0-1 Start Address Low registers 61
System Memory Map 0-4 End Address High registers 67
System Memory Map 0-4 End Address Low registers 67
System Memory Map 0-4 Start Address High registers 66
System Memory Map 0-4 Start Address Low registers 65
System Memory Map 0-4 Upper Address registers 78

T

Timer Set 60, 61, 87
Timer Set 0 68
Timer Set 1 68
timing
 16-bit system to 8-bit I/O card: odd byte timing 107
 FRAME#, AD[31:0], C/BE[3:0]#, and DEVSEL# 96
 IDSEL timing 98
 IRQ pulse mode timing 100
 memory read/write timing 102
 normal byte read/write timing 106
 PAR timing 99
 PCMCIA read/write timing when host is 8 bit 105
 PCMCIA, description 31
 STOP# delay 98
 TRDY# delay 98
 word I/O read/write timing 104
Timing Register Select 0 bit 60
Timing Register Select 1 bit 61
Timing registers 87–90
TRDY# 15, 16

U

Upper Address bits 78

V

V_{CC} 3.3V bit 70
V_{CC} Power bit 52
V_{CC} Power Lock bit 77
-VCC_3 20
-VCC_5 21
Vendor ID and Device ID register 36
Vendor ID bits 36
VPP_PGM 20
VPP_VCC 20
V_{pp1} Power bits 51
VS1/GPSTB1 20
VS2/GPSTB2 20



W

-WAIT 19

Wait Cycle Enable bit 38
waveform. *See* timing

-WE 18

Window Data Size bit 66
windowing 23

WP/-IOIS16 18

write FIFO 31

Write Protect bit 50, 69

Z

Zoomed Video Port 26