

DATA SHEET



**Cologne
Chip
Designs**

HFC - U 2BD

**ISDN HDLC FIFO controller
for U interface**

Copyright 1994, 1995, 1996 Cologne Chip Designs
All Rights Reserved

The information presented can not be considered as
assured characteristics. Data can change without notice.
Parts of the information presented may be protected by
patent or other rights.

March 1997

Contents

1 General description	4
1.1 Applications	5
1.2 Mode description	5
1.2.1 ISA-PC mode	5
1.2.2 Processor interface modes	6
2 Pin description	7
2.1 ISA-PC bus and microprocessor interface	7
2.2 SRAM Interface	8
2.3 Oscillator	9
2.4 GCI/IOM bus interface	10
2.5 Slot enable signals	10
2.6 Interrupt outputs	11
2.7 Reset	11
2.8 Miscellaneous pins	11
2.9 Power supply	12
2.10 RESET characteristics	12
3 Functional description.....	13
3.1 ISA-PC mode	13
3.1.1 Programming of I/O addresses	13
3.1.2 ISA-PC bus interface	14
3.2 Processor mode	15
3.3 Register description	16
3.3.1 FIFO control registers	16
3.3.2 Registers of the GCI/IOM bus section	17
3.3.3 Interrupt and status register	18
3.4 Watchdog / timer	18
3.5 FIFOs	19
3.5.1 FIFO channel operation	20
3.5.1.1 Send channels (B1, B2 and D transmit)	20
3.5.1.2 FIFO full condition in send channels	21
3.5.1.3 Receive Channels (B1, B2 and D receive)	21
3.5.1.4 FIFO full condition in receive channels	22
3.5.1.5 FIFO initialisation	23
3.5.2 Transparent mode of HFC-U	24
3.6 External SRAM	25
3.7 Busy synchronisation	26
3.7.1 Busy synchronisation with status read	26
3.7.2 Busy synchronisation with IOCHRDY	27
4 Register bit description	28
4.1 Register bit description of GCI/IOM bus section	28
4.2 Register bit description of interrupt, status and control registers	30
5 Electrical characteristics	35
6 Timing characteristics.....	37
6.1 ISA-PC bus or processor access	37
6.2 SRAM access	38
6.3 GCI/IOM timing	39
7 GCI frame structure.....	41
8 HFC-U package dimensions	42

Figures

Figure 1: HFC-U block diagram..... 5
Figure 2: Pin Connection..... 7
Figure 3: FIFO Organisation (shown for B-channel, similar for D-channel) 20
Figure 4: FIFO Data Organisation..... 22
Figure 5: Timing relations and delayed BUSY..... 26
Figure 6: Function of IOCHRDY..... 27
Figure 7: Single channel GCI format..... 41
Figure 8: HFC-U package dimensions..... 42

Tables

Table 1: Selected I/O address after reset 13
Table 2: SRAM size and FIFO depth..... 25

Timing Diagrams

Timing Diagram 1: ISA-PC bus or processor access..... 37
Timing Diagram 2: SRAM access 38
Timing Diagram 3: GCI/IOM timing 39

Features

- Independent Read and Write HDLC-Channels f or 2 ISDN B-channels and one ISDN D-channel
- B1 and B2 transparent mode independently selectable
- FIFO-depth: 4x 7.5 KByte (B-channel) and 2x 512 Byte (D-channel)
- max. 31 HDLC frames (B-channel) and 15 HDLC frames (D-channel) per channel and direction in FIFO
- 56 kbit/s restricted mode for U.S. ISDN lines selectable
- PCM30 interface configurable to interface MITEL ST™ bus (MVIP™), Siemens IOM2™ or GCI™ for interface to U-chip
- direct 8 bit ISA-PC bus interface with buffers for ISA-databus
- One of 6 interrupt channels on ISA-PC bus selectable by software
- Only 2 I/O-addresses used on ISA-PC bus
- programmable ISA-I/O-addresses
- microprocessor interface compatible to Motorola bus and Siemens/Intel bus
- Timer with interrupt and watchdog capability in processor mode
- 3-5V supply voltage
- rectangular QFP 100 case

1 General description

The HFC-U is an ISDN HDLC basic rate controller for so called „passive“ ISDN PC cards with integrated interface to U-chip. It only needs a U-chip and an external SRAM to form a high performance ISDN PC card. Most problems with passive ISDN PC cards as small FIFOs and massive interrupt load for the host CPU are overcome by the HFC-U. So we call ISDN cards with the HFC-U „semi-active“.

Additionally the HFC-U can be used as a microprocessor peripheral in non-PC applications.

The FIFOs of the HFC-U are realized with an external SRAM. Also an industrial standard serial interface for telecom peripheral ICs is implemented. A U-chip is normally connected to this interface.

1.1 Applications

- ISDN PC card
- ISDN terminal adapter
- ISDN PABX
- ISDN modems

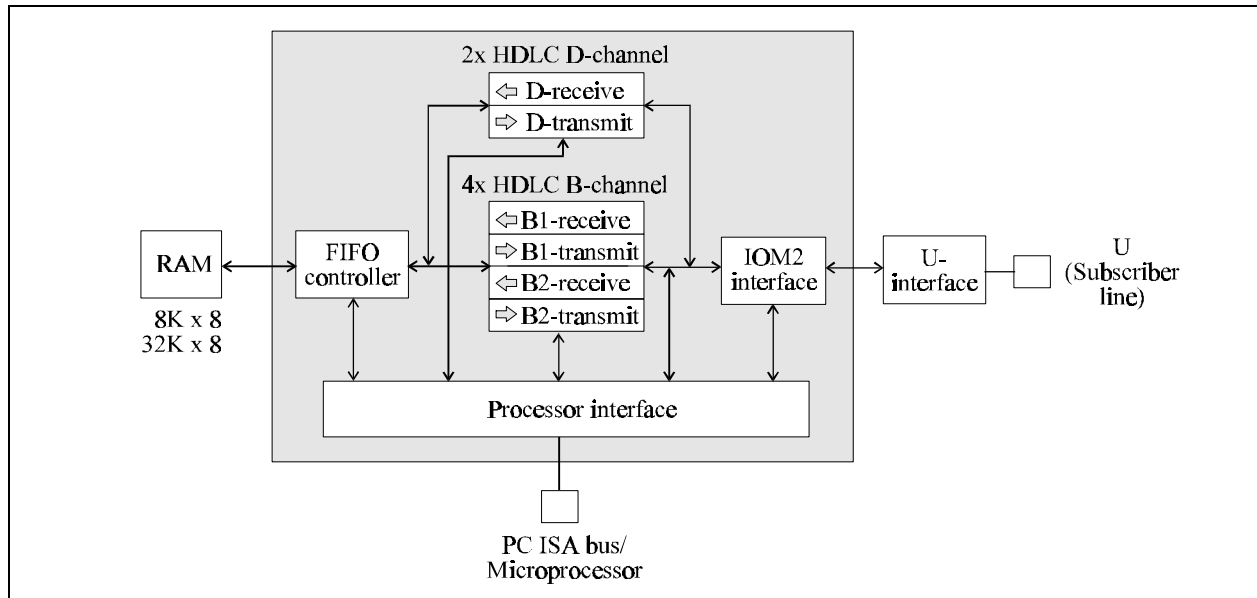

Figure 1: HFC-U block diagram

1.2 Mode description

The HFC-U has 4 different bus modes, which can be selected by the lines ALE and IIOSEL0-IIOSEL3.

Depending on the selected mode the function of several pins is different (see: Pin description).

1.2.1 ISA-PC mode

Mode 1: ALE to GND, IIOSEL3-0 from 0001 to 1111

In mode 1 the HFC-U is addressed by two successive port addresses on the ISA-PC bus. The port address is selected by the lines SA0 - SA9.

The address with SA0='1' is for register selection and the address with SA0='0' is used for data read/write (see also: 3.1).

1.2.2 Processor interface modes

The processor modes are selected by IIOSEL3-0 = '0000' (see also 3.2).

- Mode 2: Motorola bus with control signals /CS, R/W, /DS is selected by setting ALE to VDD.
- Mode 3: Siemens/Intel bus with separated address bus and databus and control signals /CS, /WR, /RD is selected by setting ALE to GND.
- Mode 4: Intel bus with multiplexed address and databus with control signals /CS, /WR, /RD, ALE.
ALE latches the address. The addresslines SA0-SA7 must be connected to the datalines BD0-BD7.

The lines SA0-SA7 are used for direct addressing the internal registers of the HFC-U.

2 Pin description

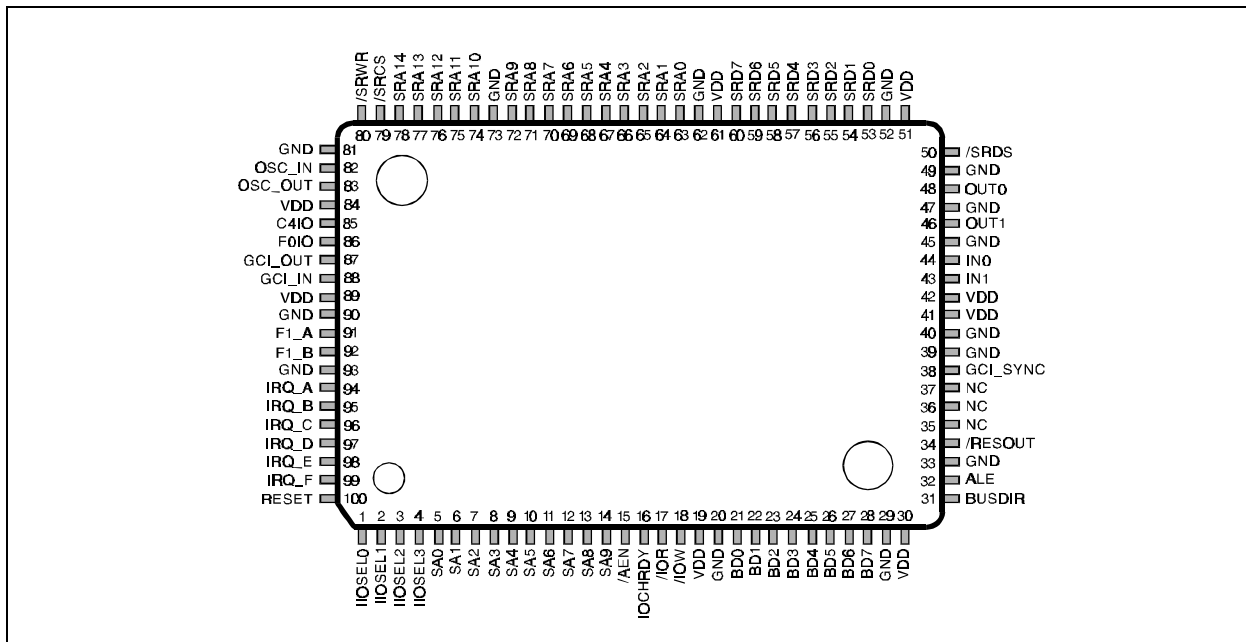

Figure 2: Pin Connection

2.1 ISA-PC bus and microprocessor interface

Pin No.	Pin Name	Input Output Tristate	Mode	Function
1	IIOSEL0	I ^{u)}	all	Mode/initial I/O address select bit 0
2	IIOSEL1	I ^{u)}	all	bit 1
3	IIOSEL2	I ^{u)}	all	bit 2
4	IIOSEL3	I ^{u)}	all	bit 3
5	SA0	I	all	Regsiter/ISA-PC address bus Address bit 0
6	SA1	I	all	Address bit 1
7	SA2	I	all	Address bit 2
8	SA3	I	all	Address bit 3
9	SA4	I	all	Address bit 4
10	SA5	I	all	Address bit 5
11	SA6	I	all	Address bit 6
12	SA7	I	all	Address bit 7
13	SA8	I	1	Address bit 8
14	SA9	I	2,3,4	must be connected to GND or VDD
		I	1	Address bit 9
		I	2,3,4	must be connected to GND or VDD

^{u)} internal pull up

Pin No.	Pin Name	Input Output Tristate	Mode	Function
15	/AEN /CS	I I	1 2,3,4	PC bus address enable chipselect low active
16	IOCHRDY	OT ¹⁾ OT ¹⁾	1 2,3,4	I/O channel ready low active wait signal for external processor
17	/IOR /DS	I I	1,3,4 2	I/O read enable I/O data strobe
18	/IOW R/W	I I	1,3,4 2	I/O write enable Read/Write select (WR='0')
21	BD0	I/O	all	Databus bit 0 (LSB)
22	BD1	I/O	all	Databus bit 1
23	BD2	I/O	all	Databus bit 2
24	BD3	I/O	all	Databus bit 3
25	BD4	I/O	all	Databus bit 4
26	BD5	I/O	all	Databus bit 5
27	BD6	I/O	all	Databus bit 6
28	BD7	I/O	all	Databus bit 7 (MSB)
31	BUSDIR	O	all	Databus direction signal for external busdriver '0' BD0-BD7 are outputs
32	ALE	I		Address latch enable ALE to GND and IIOSEL0-3 ≠0000: mode 1 ALE to VDD and IIOSEL0-3=0000: mode 2 ALE to GND and IIOSEL0-3=0000: mode 3 pulse on ALE and IIOSEL0-3=0000: mode 4

¹⁾ open drain, external pull up resistor required

2.2 SRAM Interface

Pin No.	Pin Name	Input Output Tristate	Function
53	SRD0	I/O	SRAM data bus SRAM data bit 0 (LSB)
54	SRD1	I/O	SRAM data bit 1
55	SRD2	I/O	SRAM data bit 2
56	SRD3	I/O	SRAM data bit 3
57	SRD4	I/O	SRAM data bit 4
58	SRD5	I/O	SRAM data bit 5
59	SRD6	I/O	SRAM data bit 6
60	SRD7	I/O	SRAM data bit 7 (MSB)
63	SRA0	O	SRAM address bus SRAM address bus bit 0 (LSB)
64	SRA1	O	SRAM address bus bit 1

Pin No.	Pin Name	<u>I</u> <u>O</u> <u>Tristate</u>	Function
65	SRA2	O	SRAM address bus bit 2
66	SRA3	O	SRAM address bus bit 3
67	SRA4	O	SRAM address bus bit 4
68	SRA5	O	SRAM address bus bit 5
69	SRA6	O	SRAM address bus bit 6
70	SRA7	O	SRAM address bus bit 7
71	SRA8	O	SRAM address bus bit 8
72	SRA9	O	SRAM address bus bit 9
74	SRA10	O	SRAM address bus bit 10
75	SRA11	O	SRAM address bus bit 11
76	SRA12	O	SRAM address bus bit 12
77	SRA13	O	SRAM address bus bit 13
78	SRA14	O	SRAM address bus bit 14 (MSB)
			SRAM control signals
50	/SRDS	O	Data strobe to external device
79	/SRCS	O	SRAM chip select
80	/SRWR	O	SRAM write enable

2.3 Oscillator

82	OSC_IN	I	Oscillator input or quartz connection 12.288 Mhz for HFC-U with PCM30 bus function
83	OSC_OUT	O	Oscillator output or quartz connection

2.4 GCI/IOM bus interface

Pin No.	Pin Name	Input Output Tristate	Mode	Function
85	C4IO	I/O ^{u)}	all	double bit clock GCI/IOM bus clock master output GCI/IOM bus clock slave input (reset default)
86	F0IO	I/O ^{u)}	all	Frame synchronisation, 8kHz pulse for GCI/IOM bus frame synchronisation GCI/IOM bus master output GCI/IOM bus slave input (reset default)
87	GCI_OUT	I/OT ^{u)}	all	GCI/IOM bus data II output B1/B2 slot programmable as input or output
88	GCI_IN	I/OT ^{u)}	all	GCI/IOM bus data I input B1/B2 slot programmable as input or output
38	GCI_SYNC	I ^{u)}	all	synchronisation input for GCI in master mode Must be feed with 8 kHz signal or left open.

^{u)} internal pull up

2.5 Slot enable signals

(e. g. for PCM codecs)

91	F1_A	O	all	enable signal for external CODEC A Programmable as positive (reset default) or negative pulse.
92	F1_B	O	all	enable signal for external CODEC B or 2nd HFC- U Programmable as positive (reset default) or negative pulse.

2.6 Interrupt outputs

Pin No.	Pin Name	Input Output Tristate	Mode	Function
94	IRQ_A /IRQ_P	OT OT ¹⁾	1 2,3,4	PC bus interrupt request A processor interrupt request low active
95	IRQ_B IRQ_P	OT OT ²⁾	1 2,3,4	PC bus interrupt request B processor interrupt request high active
96	IRQ_C /WD_RES	OT OT ¹⁾	1 2,3,4	PC bus interrupt request C Watchdog expired, external reset low active
97	IRQ_D WD_RES	OT OT ²⁾	1 2,3,4	PC bus interrupt request D Watchdog expired, external reset high active
98	IRQ_E	OT	1	PC bus interrupt request E
99	IRQ_F	OT	1	PC bus interrupt request F

1) open drain, external pull up resistor required

2) open source, external pull down resistor required

2.7 Reset

34	/RESOUT	O	all	Reset output for external device (low active) /RESOUT becomes active when RESET is active or soft reset is active
100	RESET	I	all	Reset for HFC-U (high active)

2.8 Miscellaneous pins

35, 36, 37	NC			No connection (leave pins open)
44	IN0	I	all	input pin 0, e. g. for power U-line detect
43	IN1	I	all	input pin 1, e. g. for power U-line detect
48	OUT0	O	all	output pin 0, e. g. for external LEDs
46	OUT1	O	all	output pin 1, e. g. for external LED

2.9 Power supply

Pin No.	Pin Name	Function
19, 30, 41, 42, 51, 61, 84, 89	VDD	VDD (+3V to +5V)
20, 29, 33, 39, 40, 45, 47, 49, 52, 62, 73, 81, 90, 93	GND	GND

 **important!**

All power supply pins VDD and GND must be directly connected to each other.

To keep VDD and GND bounce to a minimum a bypass capacitor (10 nF to 100 nF) should be placed between each pair of VDD/GND pins.

2.10 RESET characteristics

C4IO and F0IO are inputs are reset.

The lines F1_A and F1_B are '0'.

Registers which are cleared are explained in the register section of this data sheet.

3 Functional description

3.1 ISA-PC mode

3.1.1 Programming of I/O addresses

The HFC-U occupies two consecutive addresses in the I/O map of a PC if it is in ISA-PC mode. It decodes only the 10 lower address lines as most slot cards do on the ISA-PC bus. On the lower of both addresses SA0 = 0; on the higher SA0=1.

After every Master Reset (RESET = 1) the I/O address select circuit inside the HFC-U is in hardware mode. In this mode the HFC-U can not be accessed until it is initialised to an I/O address.

At first one of 15 different I/O addresses must be selected by the 4 inputs IIOSEL0 .. IIOSEL3 as Table 1 shows:

IIOSEL 3 2 1 0	Selected I/O address
0 0 0 0	processor mode
0 0 0 1	2E0h
0 0 1 0	2D0h
0 0 1 1	210h
0 1 0 0	2C0h
0 1 0 1	200h
0 1 1 0	2F8h
0 1 1 1	2E8h
1 0 0 0	2B0h
1 0 0 1	3E0h
1 0 1 0	320h
1 0 1 1	278h
1 1 0 0	310h
1 1 0 1	330h
1 1 1 0	300h
1 1 1 1	3E8h

Table 1: Selected I/O address after reset

The hardware selected I/O address might have an address collision with another I/O device in the PC.

After a hardware reset (RESET = 1) you must first write an I/O address into the HFC-U to set the I/O address for every further access to the device.

The procedure is as follows:

First you must write the lower 8 bits of the new I/O address you want into the lower address (SA0 = 0) of the hardware selected I/O address. The LSB of the new address is a don't care bit because the HFC-U always occupies two I/O addresses.

The HFC-U has no memory or DMA access to any component on the ISA-PC bus.

Because of its power drive characteristic it needs no external driver for the ISA-PC bus data lines.

If necessary you can add an external bus driver. In this case the output BUSDIR determines the driver direction.

BUSDIR = 1 means that data is driven into the HFC-U;

BUSDIR = 0 means that the HFC-U is read and data is driven to the external bus.

3.2 Processor mode

In the microprocessor mode the HFC-U uses 256 I/O addresses (SA0 - SA7).

/IOR /DS	/IOW R/W	/CS	ALE	Operation	Mode
X	X	1	X	no access	all
1	1	X	X	no access	all
0	1	0	1	read data	2
0	0	0	1	write data	2
0	1	0	0	read data	3
1	0	0	0	write data	3
0	1	0	0 ^{*)}	read data	4
1	0	0	0 ^{*)}	write data	4

X = don't care

^{*)} 1-pulse latches I/O address.

All registers are directly accessible by their I/O address (see register description).

Except in mode 4 ALE is assumed to be stable after a RESET.

3.3 Register description

In ISA-PC mode all registers are selected by first writing the address into the Control Internal Pointer (CIP) register. This is done by writing the HFC-U on the higher address SA0 = 1.

All consecutive read or write data accesses (SA0 = 0) are done with the selected register until the CIP register is changed.

In processor mode all registers can be directly accessed. The registers are selected by SA0 - SA7.

3.3.1 FIFO control registers

The FIFO control registers are used to select and control the FIFOs of the HFC-U. In processor mode the value is the address which directly selects the corresponding register.

CIP / I/O-address

10zzzzzd **z**: 5 bits for D-channel FIFO register control

10yyyyff **y**: 4 bits for B-channel FIFO register control

yyyy	zzzz		
0000	01000	FIFO input counter (Z1) low byte	r)
0001	01010	FIFO input counter (Z1) high byte	r)
0010	01100	FIFO output counter (Z2) low byte	r)
0011	01110	FIFO output counter (Z2) high byte	r)

HDLC mode:

1010	01001	dummy for increment of frame counter (F1)	r)
1011	01011	data write into FIFO and increment Z1	w)
1100	01101	FIFO input HDLC frame counter (F1)	r)
1101	01111	FIFO output HDLC frame counter (F2)	r)
1110	10001	dummy for increment of frame counter (F2)	r)
1111	10011	data read out of FIFO and increment Z2	r)

Transparent mode (only selectable for B-channels):

1010		data write into FIFO upside down and increment Z1	w)
1011		data write into FIFO and increment Z1	w)
1100		FIFO input HDLC frame counter (F1)	r)
1101		FIFO output HDLC frame counter (F2)	r)
1110		data read out of FIFO upside down and increment Z2	r)
1111		data read out of FIFO and increment Z2	r)

f: B-channel FIFO-No.:

00	channel B1 transmit	10	channel B2 transmit
01	channel B1 receive	11	channel B2 receive

d: D-channel FIFO-No.:

0	D-channel transmit direction
1	D-channel receive direction

r) corresponding data register is read only

w) corresponding data register is write only

👉 important!

FIFO change

Changing the FIFO must be the last FIFO operation in a non BUSY phase. The new FIFO is selected after one busy phase.

To select a new FIFO in processor mode a dummy value must be written to the Z1 register address of this FIFO. The Z1 register is not changed by this operation.

Incrementation of the frame counters (F1, F2)

If the frame counters (F1, F2) are changed it must be in a separate non BUSY period. That means writing data to the FIFO or reading data from the FIFO is not allowed during this period. Also selecting a new FIFO is not allowed. Reading the counters Z1, Z2, F1 and F2 is allowed before incrementing the frame counter.

Accessibility of registers

All operations on the FIFOs and on FIFO control registers and on B- and D-channel data registers of the GCI/IOM bus part are only allowed in the non BUSY period of the HFC-U.

Status, interrupt and control registers can be read/written at any time.

3.3.2 Registers of the GCI/IOM bus section

GCI/IOM bus timeslot selection registers

CIP / I/O-address	Name	r/w	Function
00100000 20h	B1_SL	w	B1-slot mode register
00100001 21h	B2_SL	w	B2-slot mode register
00100010 22h	C/I	r/w	C/I command/indication register
00100011 23h	TRxR	r	Monitor Tx and Rx ready handshake

GCI/IOM bus data registers

CIP / I/O-address	Name	r/w	Function
00101000 28h	B1_D ^{*)}	r/w	B1 channel data register (slot #0 data)
00101001 29h	B2_D ^{*)}	r/w	B2 channel data register (slot #1 data)
00101010 2Ah	MON1_D	r/w	first monitor byte (slot #2 data)
00101011 2Bh	MON2_D	r/w	second monitor byte (slot #2 data)
00101100 2Ch	D_D ^{*)}	w	
00101110 2Eh	MST_MODE	w	mode register for GCI/IOM bus

^{*)} These registers are read/written automatically by the HDLC FIFO controller (HFC).

3.3.3 Interrupt and status register

CIP / I/O address	Name	r/w	Function
00011000 18h	CIRM	w	interrupt selection and softreset register
00011001 19h	CTMT	w	transparent mode and time control register
00011010 1Ah	INT_M1	w	interrupt mask register 1
00011011 1Bh	INT_M2	w	interrupt mask register 2 and B-channel mode register (64 kbit/s or 56 kbit/s)
00011110 1Eh	INT_S1	r	interrupt status register
00011100 1Ch	STATUS	r	common status register
00011101 1Dh	STATUS_DISBUSY		same as STATUS register but also locks busy-nobusy transition (see also 3.7.1)

3.4 Watchdog / timer

The watchdog function of the HFC-U has two different modes which can be selected by bit 5 of the CTMT register.

In the first mode the watchdog timer expires after the selected time if the timer has been reset and the INT_S1 register is not read during the watchdog timer period.

In the second mode the watchdog timer expires after the selected time if no HFC-U register is accessed during the watchdog timer period. In this mode every access to the HFC-U resets the watchdog **and** the timer.

3.5 FIFOs

There are 6 FIFOs with 6 HDLC-Controllers in the HFC-U. The HDLC circuits are located on the GCI/IOM side of the HFC-U. So always plain data is stored in the FIFO. Zero insertion and deletion is done:

- if the data goes to GCI/IOM interface in send FIFOs and
- when the HDLC data comes from GCI/IOM interface in receive operation.

There are a send and a receive FIFO for each of the two B-channels and for the D-channel.

The FIFOs are realized as ring buffers in the external SRAM. To control them there are some counters.

	B-channel	D-channel
Z1: FIFO input counter	13 Bit	9 Bit
Z2: FIFO output counter	13 Bit	9 Bit

Each counter points to a byte position in the SRAM. On a FIFO input operation Z1 is incremented. On an output operation Z2 is incremented.

After every pulse on the F0IO signal the HFC-U goes into busy cycle and two HDLC-bytes are written into the GCI/IOM interface (FIFOs No. 0 and 2) and two HDLC-bytes are read from the GCI/IOM interface (FIFOs No. 1 and 3).

D-channel data is handled in a similar way.

If $Z1 = Z2$ the FIFO is empty.

Additionally there are two counters F1 and F2 for every FIFO channel (5Bit for B-channel, 4Bit for D-channel). They count the HDLC-frames in the FIFOs and form a ring buffer as Z1 and Z2 do, too.

Again F1 is incremented when a complete frame has been received and stored in the FIFO. F2 is incremented when a complete frame has been read from the FIFO.

If $F1 = F2$ there is no complete frame in the FIFO.

When the RESET line is active or software reset is active Z1, Z2, F1 and F2 are all initialized to all 1s.

👉 important!

The counter state 0200h of the Z-counters follows counter state 1FFFh in the B-channel FIFOs.
The counter state 000h of the Z-counters follows counter state 1FFh in the D-channel FIFOs.

The counter state 00h of the F-counters follows counter state 1Fh in the B-channel FIFOs.
The counter state 10h of the F-counters follows counter state 1Fh in the D-channel FIFOs.

3.5.1 FIFO channel operation

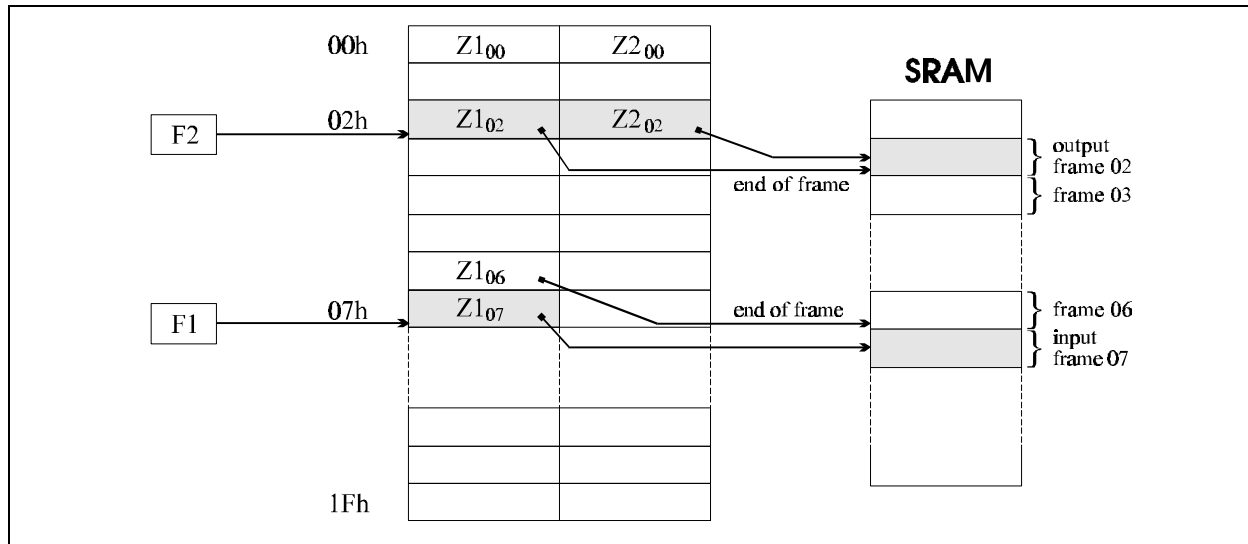

Figure 3: FIFO Organisation (shown for B-channel, similar for D-channel)

3.5.1.1 Send channels (B1, B2 and D transmit)

The send channels send data from the ISA-PC/processor bus interface to the FIFO and the HFC-U converts the data into HDLC code and transfers it from the FIFO into the GCI/IOM interface write registers.

The HFC-U checks Z1 and Z2. If $Z1=Z2$ (FIFO empty) the HFC-U generates a HDLC-Flag (0111 1110) and sends it to the GCI/IOM interface. In this case Z2 is not incremented. If also $F1=F2$ only HDLC flags are sent to the GCI/IOM interface and all counters remain unchanged. If the frame counters are unequal F2 is incremented and the HFC-U tries to send the next frame to the output device. After the end of a frame (Z2 reaches Z1) it automatically generates the 16 bit CRC checksum and adds the ending flag. If there is another frame in the FIFO ($F1 \neq F2$) the F2 counter is incremented.

With every byte you send to the FIFO via the ISA-PC bus interface Z1 is incremented automatically. If a complete frame has been send F1 must be incremented to send the next frame. If the frame counter F1 is incremented also the Z-counters may change because Z1 and Z2 are functions of F1 and F2. So there are $Z1(F1)$, $Z2(F1)$, $Z1(F2)$ and $Z2(F2)$ (see Figure 3).

$Z1(F1)$ is used for the frame which is just written from the PC-bus side. $Z2(F2)$ is used for the frame which is just being transmitted to the GCI/IOM side of the HFC-U. $Z1(F2)$ is the end of frame pointer of the current output frame.

In the send channels F1 is only changed from the PC interface side if the software driver wants to say „end of send frame“. Then the current value of Z1 is stored, F1 is incremented and Z1 is used as start address of the next frame. $Z1(F2)$ and $Z2(F2)$ can not be accessed.

👉 important!

At the start of the first frame when the FIFO is totally empty at least two bytes must be put into the FIFO before a BUSY condition is initialized by the HFC-U. This is necessary to avoid the initialisation of a CRC sequence after a one-byte frame. To satisfy this condition you should wait for a BUSY / NOBUSY status transition. In this case there is enough time to write more than one byte into the FIFO.

3.5.1.2 FIFO full condition in send channels

Due to the limited number of registers in the HFC-U the driver software must maintain a list of frame start and end addresses to calculate actual FIFO depth and check FIFO full condition. Because there are a maximum of 32 frame counter values and the start address of a frame is the incremented value of the last frame end address the memory table must have only 32 values of 16 bits (13 bits) instead of 64.

Remember that an increment of Z-value 1FFFh is 0200h in the B-channels!

There are two different FIFO full conditions. The first one is met when the FIFO contents comes up to 31 frames (B-channel) or 15 frames (D-channel). There is no possibility for the HFC-U to manage more frames even if the frames are very small.

The second limitation is the depth of the FIFO which is 512 byte for the D-channel and 7.5 KByte for the B-channel (32KByte external RAM).

3.5.1.3 Receive Channels (B1, B2 and D receive)

The receive channels receive data from the GCI/IOM bus interface read registers. The data is converted from HDLC into plain data and send to the FIFO. The data can then be read via the processor interface.

The HFC-U checks the HDLC data coming in. If it finds a flag or more than 5 consecutive 1s it does not generate any output data. In this case Z1 is not incremented. Proper HDLC data being received is converted by the HFC-U into plain data. After the ending flag of a frame the HFC-U checks the HDLC CRC checksum. If it is correct one byte with all 0s is inserted behind the CRC data in the FIFO named STAT. This last byte of a frame in the FIFO is different from all 0s if there is no correct CRC field at the end of the frame.

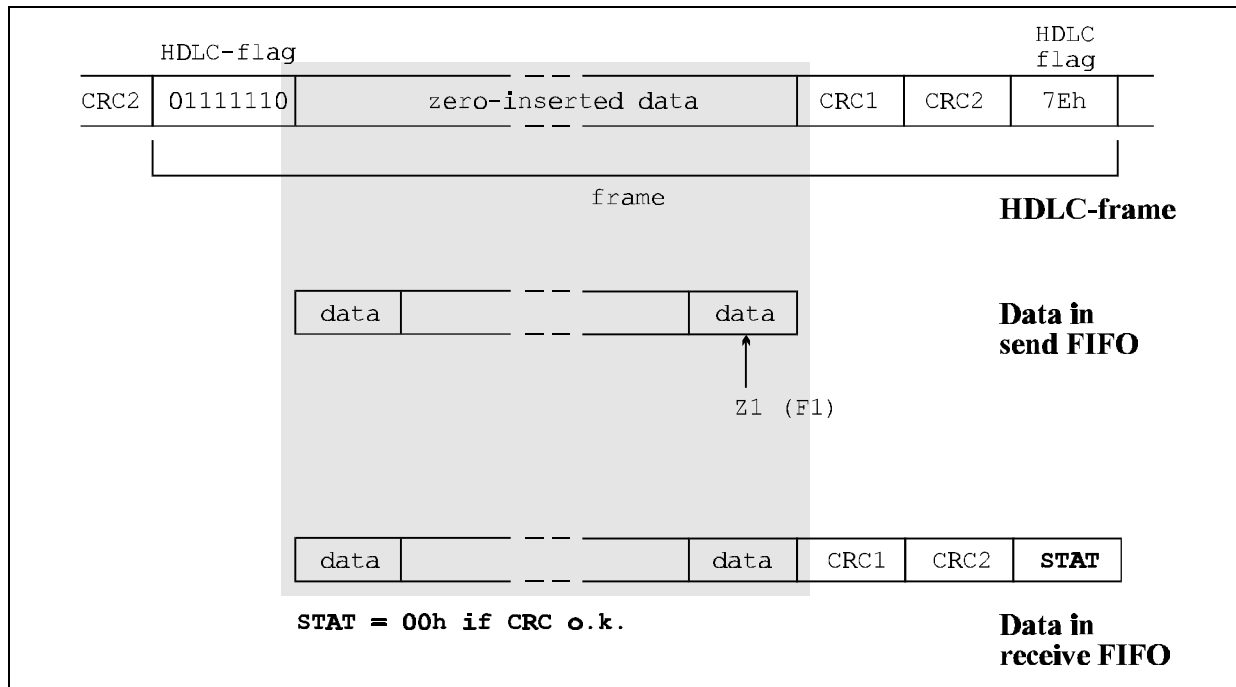

Figure 4: FIFO Data Organisation

The ending flag of a HDLC-frame can also be the starting flag of the next frame.

After a frame is received completely F1 is incremented by the HFC-U automatically and the next frame can be received.

After reading a frame via the processor bus interface F2 must be incremented. If the frame counter F2 is incremented also the Z-counters may change because Z1 and Z2 are functions of F1 and F2. So there are Z1(F1), Z2(F1), Z1(F2) and Z2(F2) (see Figure 3).

Z1(F1) is used for the frame which is just received from the GCI/IOM side of the HFC. Z2(F2) is used for the frame which is just being transmitted to the ISA-PC bus interface. Z1(F2) is the end of frame pointer of the current output frame.

To calculate the length of the current receive frame the software has to evaluate Z1-Z2. When Z2 reaches Z1 the complete frame has been read.

In the receive channels F2 must be incremented from the PC interface side after the software detects an end of receive frame (Z1=Z2) and F1 ≠ F2. Then the current value of Z2 is stored, F2 is incremented and Z2 is copied as start address of the next frame. If Z1 = Z2 and F1 = F2 the FIFO is totally empty. Z1(F1) can not be accessed.

3.5.1.4 FIFO full condition in receive channels

Because the ISDN-B-channels and the ISDN-D-channels have no hardware based flow control there is no possibility to stop input data if a receive FIFO is full.

So there is no FIFO full condition implemented in the HFC-U. The HFC-U assumes that the FIFOs are so deep that the host processor hardware is able to avoid any overflow of the receive FIFOs. Overflow conditions are again more than 31 input frames (15 frames for D-channel) or a real overflow of the FIFO because of excessive data.

Because HDLC procedures only know a window size of 7 frames no more than 7 frames are send without software intervention. Due to the great depth of the FIFOs of the HFC-U it is easy to poll the HFC-U even in large time intervalls without having to fear a FIFO overflow condition.

However to avoid any undetected FIFO overflows the software driver should check the number of frames in the FIFO which is F1-F2. An overflow exists if the number (F1-F2) is less than the number in the last reading even if there was no reading of a frame in between.

After a detected FIFO overflow condition the HFC-U must be reset via the software or hardware RESET!

3.5.1.5 FIFO initialisation

All counters Z1, Z2, F1 and F2 of all FIFOs are initialized to all 1s after a RESET.

Then the result is $Z1 = Z2 = 1FFF_h$ and $F1 = F2 = 1F_h$ for the B-channels and $Z1 = Z2 = 1FFh$ and $F1 = F2 = 1Fh$ for the D-channel.

Please mask bit 4 of D-channel from counter F1, F2.

The same initialisation is done if the bit 3 in the CIRM register is set (soft reset).

3.5.2 Transparent mode of HFC-U

You can switch off HDLC operation for each B-channel independently. There is one bit for each B-channel in the CTMT control register. If this bit is set data in the FIFO is send directly to the GCI/IOM bus interface and data from the GCI/IOM bus interface is send directly to the FIFO.

Be sure to switch into transparent mode only if $F1=F2$. Being in transparent mode the F_x counters remain unchanged. $Z1$ and $Z2$ are the input and output pointers respectively. Because $F1=F2$ both Z -counters are always accessable and have valid data.

If a send FIFO channel changes to FIFO empty condition no CRC is generated and the last data byte written into the FIFO is repeated until there is new data.

In receive channels there is no check on flags or correct CRCs and no status byte is added.

The byte bounderies are not arbitrary like in HDLC mode where byte synchronisation is achieved with HDLC-flags. The data is just the same as it comes from the GCI/IOM bus interface or is send to this.

Because F_x incrementation dummy registers are not used you can send and receive transparent data in two shapes. The normal and first shape is tranporting B-channel data with the LSB first as it is usual in HDLC mode. The second shape is sending the bytes upside down as it is normal for PWM data. So the first bit is the MSB.

3.6 External SRAM

For the FIFO data an 32K x 8 external SRAM is used. A 8K x 8 external RAM is also possible but not recommended.

The required access time is 80 ns or below at 12MHz clock.

1024 Byte of the external SRAM are reserved for internal HFC-U use.

external SRAM	B-channel FIFO depth per channel and direction	D-channel FIFO depth per direction
8K x 8	1536 Byte	512 Byte
32K x 8	7680 Byte	512 Byte

Table 2: SRAM size and FIFO depth

To initialise the HFC-U for 8K x 8 SRAM use:

- write 18h to the CIRM register
- write 10h to the CIRM register

For all further accesses to the CIRM register bit 4 must be set.

👉 hint!

If you connect the HFC-U with the SRAM you can simplify PCB layout if you permutate address lines and data lines. If you connect data lines of the SRAM with data lines of the HFC-U and SR-address lines of the HFC-U with address lines of the SRAM you can do this in any order.

3.7 Busy synchronisation

For internal processing of the data channels and HDLC the HFC-U enters a busy phase every 125µs on a falling F0IO edge. During this BUSY phase most of the registers must not be accessed (all FIFO registers, B1_D, B2_D and D_D).

The minimum BUSY phase time is 280 clock cycles and the maximum BUSY phase time is 630 clock cycles.

3.7.1 Busy synchronisation with status read

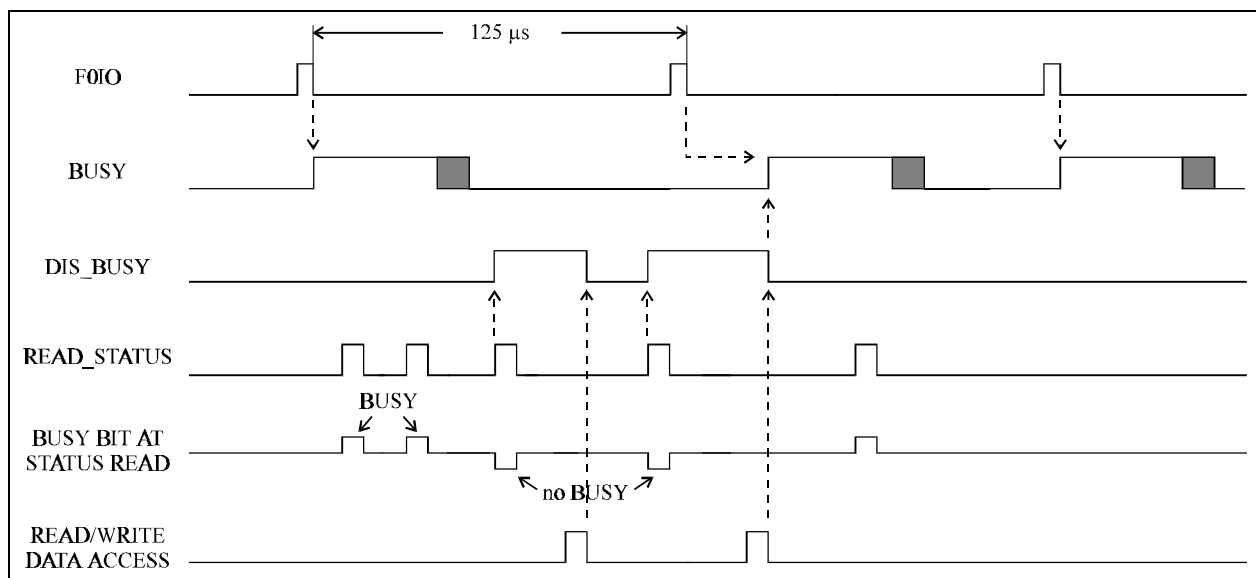

Figure 5: Timing relations and delayed BUSY

The lines BUSY and DIS_BUSY are internal signals of the HFC-U. If BUSY is high the HFC-U is in a phase when busy critical registers must not be accessed. The signal DIS_BUSY disables the start of the internal BUSY phase until the next read/write data operation is finished. To avoid loss of data the DIS_BUSY signal must not disable the BUSY so that the end of BUSY comes after the next F0IO signal (see also: STATUS register bit description).

READ_STATUS symbolizes a status read operation. The high signal means the status is read. BUSY BIT AT STATUS READ is the value returned from a read status operation (bit 0 in STATUS register). READ/WRITE DATA ACCESS symbolizes a data read/write operation.

3.7.2 Busy synchronisation with IOCHRDY

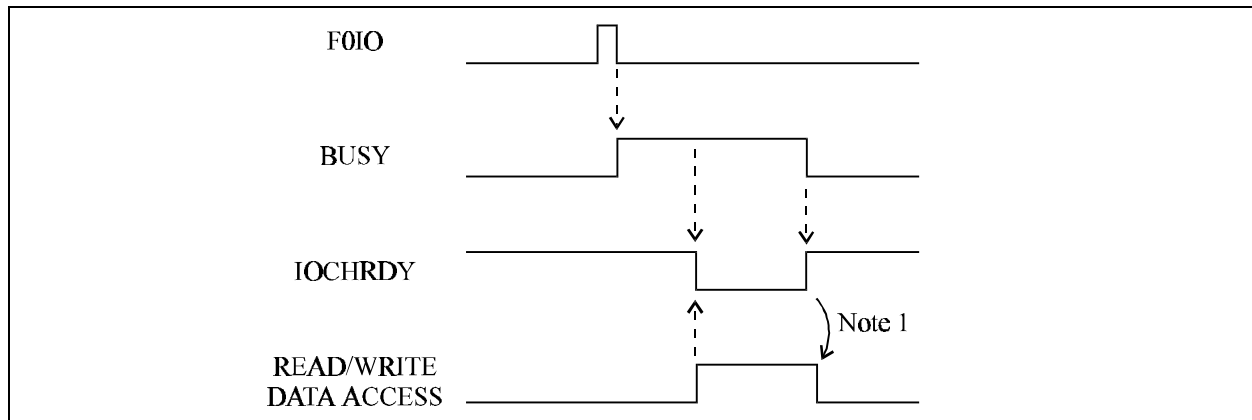

Figure 6: Function of IOCHRDY

Note 1: The read/write data access is finished by an external processor after release of IOCHRDY.

Repeated status read can be avoided if the IOCHRDY output of the HFC-U is connected to the /WAIT line of the external processor. If the HFC-U is accessed during a BUSY phase the processor waits until the end of the BUSY phase.

4 Register bit description

4.1 Register bit description of GCI/IOM bus section

Timeslots for transmit direction

Name	Addr.	Bits	r/w	Function
B1_SL	(20h)	5..0	w	unused
		6	w	select ST bus data lines '0' GCI_IN is input GCI_OUT is output '1' GCI_OUT is input GCI_IN is output
		7	w	transmit channel enable for ST bus '0' disable (default) '1' enable
B2_SL	(21h)			see B1_SL
C/I	(22h)	3..0	r/w	on read: indication on write: command
		7..4		unused
TRxR	(23h)	0	r	'1' Monitor receiver ready (2 bytes received) bit is reset after read of second Monitor byte (MON2_D)
		1		'1' Monitor transmitter ready write on MON2_D starts transmit and resets this bit
		6		data on input pin IN0
		7		data on input pin IN1
B1_D	(28h)	0..7	r/w	read/write register for B1 timeslot data
B2_D	(29h)	0..7	r/w	read/write register for B2 timeslot data
MON1_D	(2Ah)	0..7	r/w	1st monitor data byte
MON2_D	(2Bh)	0..7	r/w	2nd monitor data byte

Name	Bits	r/w	Function
D_D	(2Ch) 6,7	w	write data for D timeslot data only bit 6 and 7 valid
MST_MODE (2Eh)	0	w	GCI mode '0' slave (default) C4O and F0O are inputs '1' master C4O and F0O are outputs
	1	w	polarity of C4O clock '0' bit cell starts with falling clock (default) '1' bit cell starts with rising clock
	2	w	polarity of F0 frame sync. '0' positive pulse on F0 (default) '1' negative pulse on F0
	3	w	duration of F0 signal '0' F0 active for one C4 clock (244ns) (default) '1' F0 active for two C4 clocks (488ns)
	5, 4	w	select time slot for codec-A signal F1_A '00' slot 0 (B1) '01' slot 1 (B2) '10' signal C2O (2.048MHz) to F1_A '11' disable, no pulse
	7, 6	w	select time slot for codec-B signal F1_B '00' slot 0 (B1) '01' slot 1 (B2) '10' slot 4 (ability to cascade HFC-U) '11' disable, no pulse

The pulseshape of the codec signals is the same as the pulseshape of the F0 signals.
The polarity of C2O can be changed by bit 1.

RESET sets register MST_MODE to '0's.

4.2 Register bit description of interrupt, status and control registers

Name	Bits	r/w	Function		
CIRM	(18h)	2..0	w	select IRQ channel in PC mode '000' IRQ disable (reset default) '001' IRQ_A '010' IRQ_B '011' IRQ_C '100' IRQ_D '101' IRQ_E '110' IRQ_F '111' IRQ disable	
			3	w	soft reset, similar as hardware reset; the registers CIP, CIRM and CTMT are not changed so selected I/O address is kept in ISA-PC mode. The reset is active until the bit is cleared. '1' activate reset '0' deactivate reset (reset default)
			4	w	select memory '0' 32k x 8 external RAM (reset default) '1' 8k x 8 external RAM
			5	w	D-channel idle mode '0' flags are send in D-channel if no data is send (reset default) '1' continous ones are send in D-channel if no data is send
			6	w	clock divider '0' normal clock mode (reset default) '1' master clock is divided by 2 This bit should only be changed during soft reset.
			7	w	GCI/IOM test loop '0' normal operation '1' GCI input data is received from GCI output data GCI output data is not changed
			CTMT	(19h)	0
1	w	HDLC/transparent mode for channel B2 '0' HDLC mode (reset default) '1' transparent mode			

Name	Bits	r/w	Function										
CTMT (19h)	2	w	data output to pin OUT0 '0' (reset default)										
	4, 3	w	select timer and watchdog <table border="1"> <thead> <tr> <th>timer</th> <th>watchdog</th> </tr> </thead> <tbody> <tr> <td>'00'</td> <td>25ms 50ms (reset default)</td> </tr> <tr> <td>'01'</td> <td>50ms 100ms</td> </tr> <tr> <td>'10'</td> <td>400ms 800ms</td> </tr> <tr> <td>'11'</td> <td>800ms 1600ms</td> </tr> </tbody> </table>	timer	watchdog	'00'	25ms 50ms (reset default)	'01'	50ms 100ms	'10'	400ms 800ms	'11'	800ms 1600ms
	timer	watchdog											
	'00'	25ms 50ms (reset default)											
	'01'	50ms 100ms											
'10'	400ms 800ms												
'11'	800ms 1600ms												
5	w	timer/watchdog reset mode '0' reset timer/WD by CTMT bit 7 (reset default) '1' automatically reset timer/WD at each access to HFC-U											
6	w	data output to pin OUT1 '0' (reset default)											
7	w	reset timer/WD '1' reset timer/WD The bit is automatically cleared.											
INT_M1 (1Ah)	0	w	interrupt mask for channel B1 in transmit direction										
	1	w	interrupt mask for channel B2 in transmit direction										
	2	w	interrupt mask for channel D in transmit direction										
	3	w	interrupt mask for channel B1 in receive direction										
	4	w	interrupt mask for channel B2 in receive direction										
	5	w	interrupt mask for channel D in receive direction										
	6	w	interrupt mask for receive ready (RxR) of monitor channel										
	7	w	interrupt mask for timer										

For mask bits a '1' enables and a '0' disables interrupt. RESET clears all bits to '0'.

Name	Bits	r/w	Function
INT_M2 (1Bh)	0	w	interrupt mask for BUSY/NOBUSY transition
	1	w	interrupt mask for GCI I-change interrupt
	2	w	in 64 kbit/s mode: must be '0' in 56 kbit/s mode: value of the LSB in 7-bit mode
	3	w	enable for interrupt output '0' disable (reset default) '1' enable
	4	w	56 kbit/s mode selection bit for B1-channel '0' 64 kbit/s mode (reset default) '1' 56 kbit/s mode
	5	w	56 kbit/s mode selection bit for B2-channel '0' 64 kbit/s mode (reset default) '1' 56 kbit/s mode
	6	w	'0' Data not inverted for B1-channel (reset default) '1' Data inverted for B1-channel
	7	w	'0' Data not inverted for B2-channel (reset default) '1' Data inverted for B2-channel

For mask bits a '1' enables and a '0' disables interrupt. RESET clears all bits to '0'.

Name	Bits	r/w	Function
INT_S1 (1Eh)	0	r	B1-channel interrupt status in transmit direction
	1	r	B2-channel interrupt status in transmit direction in HDLC mode: '1' a complete frame was transmitted, the frame counter F2 was incremented in transparent mode, external RAM 32K x 8: '1' bit12 in Z2 counter changed from '0' to '1' in transparent mode, external RAM 8K x 8: '1' bit10 in Z2 counter changed from '0' to '1'
	2	r	D-channel interrupt status in transmit direction '1' a complete frame was transmitted, the framecounter F2 was incremented
	3	r	B1-channel interrupt status in receive direction
	4	r	B2-channel interrupt status in receive direction in HDLC mode: '1' a complete frame was transmitted, the frame counter F1 was incremented in transparent mode, external RAM 32K x 8: '1' bit12 in Z1 counter changed from '0' to '1' in transparent mode, external RAM 8K x 8: '1' bit10 in Z1 counter changed from '0' to '1'
	5	r	D-channel interrupt status in receive direction '1' a complete frame was received, the frame counter F1 was incremented
	6	r	receiver ready (RxR) of monitor channel '1' 2 monitor bytes have been received
	7	r	timer interrupt status '1' timer is elapsed

👉 important!

Reading the INT_S1 register resets all active read interrupts. New interrupts may occur during read. These interrupts are reported at the next read of INT_S1.

The interrupt output goes inactive during the read of INT_S1. If interrupts occur during this read the interrupt line goes active immediately after the read is finished. So processors with level or transition triggered interrupt inputs can be connected.

Name	Bits	r/w	Function
STATUS (1Ch)	0	r	BUSY/NOBUSY status '1' the HFC-U is in BUSY state '0' the HFC-U is in NOBUSY state, access on all FIFO functions is now possible
	1	r	unused, '0'
	2	r	BUSY/NOBUSY transition interrupt status '1' the HFC-U has changed from BUSY to NOBUSY state, access on all FIFO functions is now possible This bit is reset by a read of INT_S1.
	3	r	GCI I-change interrupt '1' a different I-value on GCI was detected
	4	r	timer status '0' timer not elapsed '1' timer elapsed
	5	r	receiver ready (RxR) of monitor channel '1' 2 monitor bytes have been received
	6	r	FRAME interrupt has occurred (any data channel interrupt) all masked D-channel and B-channel interrupts are "ored"
	7	r	ANY interrupt all masked interrupts are "ored"

Reading the STATUS register clears no bit.

STATUS_DISBUSY (1Dh) r see STATUS register
All bits are the same as in the STATUS register.

All processor modes:

Reading STATUS_DISBUSY register delays the transition from nobusy to busy until any other register of the HFC-U is accessed (see Figure 5 on page 26).

This register should be checked for nobusy before accessing any busy-critical register to avoid a transition from nobusy to busy during a FIFO register access, which may destroy register values.

Busy-critical register are all FIFO registers, the B-channel data register B1_D, B2_D and D_D of the GCI/IOM bus part.

ISA-PC mode:

It is possible to read the STATUS_DISBUSY register in ISA-PC mode directly by a READ operation to the port address with SA0='1', but it is necessary to enable the HFC-U going into busy cycle again after a data port access with SA0='0'.

5 Electrical characteristics

Absolute maximum ratings

Parameter	Symbol	Rating
Supply voltage	V_{CC}	-0.3V to +7.0V
Input voltage	V_I	-0.3V to $V_{CC} + 0.3V$
Output voltage	V_O	-0.3V to $V_{CC} + 0.3V$
Operating temperature	T_{opr}	-40°C to +85°C
Storage temperature	T_{stg}	-55°C to +150°C

Recommended operating conditions for TTL and CMOS interface

Parameter	Symbol	Condition	MIN.	TYP.	MAX.
Supply voltage	V_{CC}		3.0V	5.0V	5.25V
Supply current	I_{CC}	$f_{CLK}=12MHz$		18 mA	
Operating temperature	T_{opr}		0°C		+70°C

Electrical characteristics

$V_{CC} = 4.75V$ to $5.25V$ (TTL), $V_{CC} = 4.5V$ to $5.5V$ (CMOS), $T_{opr} = -10°C$ to $+70°C$

Parameter	Symbol	Condition	TTL level			CMOS level		
			MIN.	TYP.	MAX.	MIN.	TYP.	MAX.
Input LOW voltage	V_{IL}	Schmitt input buffer			0.8V			1.5V
Input HIGH voltage	V_{IH}		2.0V			3.5V		
Input HIGH threshold voltage	V_{T+}				2.2V			3.7V
Input LOW threshold voltage	V_{T-}		0.5V			1.0V		
Hysteresis voltage	V_H		0.2V			0.4V		
Output LOW voltage	V_{OL}				0.4V			0.4V
Output HIGH voltage	V_{OH}		4.0V			4.0V		
Output leakage current	$ I_{OZ} $	High Z			10 μA			10 μA
Pull-up resistor input current	$ I_{IL} $	$V_I = 0V$	8.0 μA		60 μA	8.0 μA		60 μA

I/O Characteristics

Input	Interface Level
IIOSSEL0-3	TTL, internal pull-up resistor
SA0-9	TTL
/AEN	TTL
/IOR	TTL
/IOW	TTL
BD0-7	TTL
ALE	TTL
SRD0-7	TTL
C4IO	TTL, internal pull-up resistor
F0IO	TTL, internal pull-up resistor
GCI_IN	TTL, internal pull-up resistor
GCI_OUT	TTL, internal pull-up resistor
/IRQ_P	open drain, external pull up resistor required
IRQ_P	open source, external pull down resistor required
/WD_RES	open drain, external pull up resistor required
WD_RES	open source, external pull down resistor required
RESET	CMOS Schmitt Trigger

Output	Driver Capability		
	Low		High
	0.4V	0.6V	V_{CC} - 0.4V
IOCHRDY	12mA		
BD0-7	18mA	24mA	8mA
BUSDIR	4mA		2mA
SRD0-7	2mA		1mA
SRA0-14	2mA		1mA
/SRCS	4mA		2mA
/SRWE	4mA		2mA
C4IO	6mA		3mA
F0IO	6mA		3mA
GCI_IN	6mA		3mA
GCI_OUT	6mA		3mA
F1_A-B	6mA		3mA
IRQA-F	12mA		6mA

6 Timing characteristics

6.1 ISA-PC bus or processor access

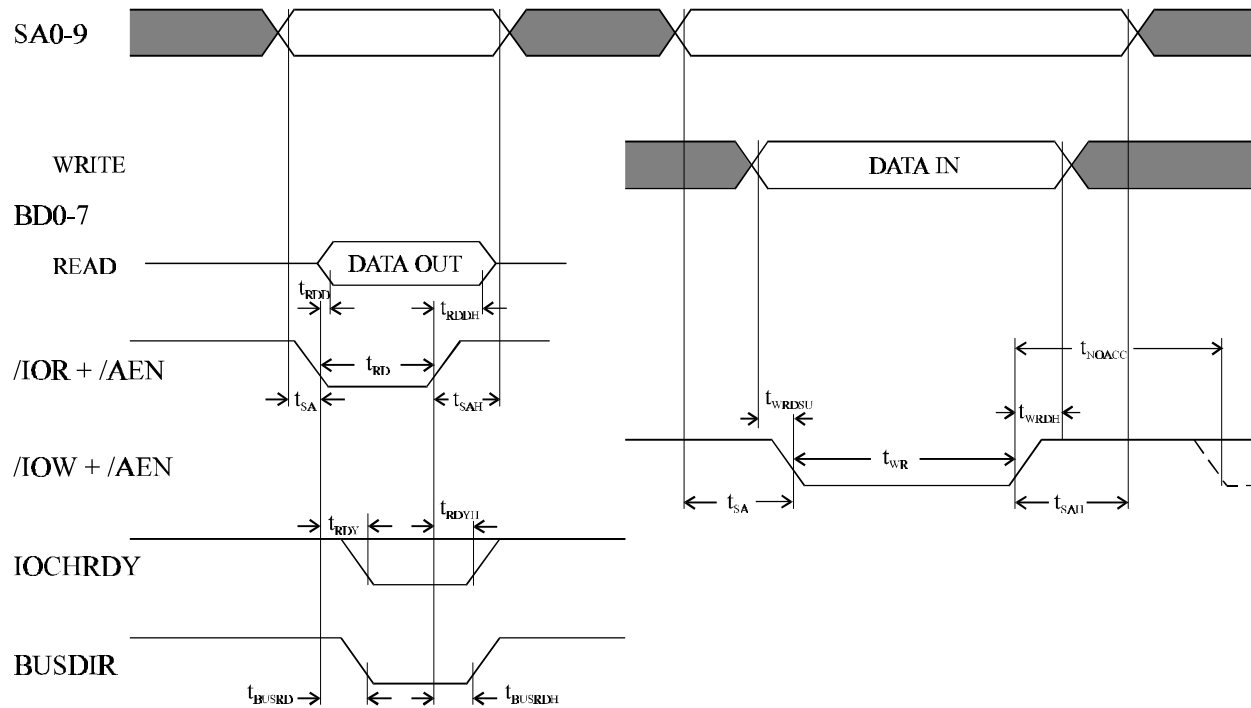

Timing Diagram 1: ISA-PC bus or processor access

SYMBOL	CHARACTERISTICS	MIN.	MAX.
t_{RDD}	/IOR Low to Read Data Out Time	3ns	25ns
t_{RDDH}	/IOR High to Data Buffer Turn Off Time	2ns	15ns
t_{SA}	Address to /IOR or /IOW Low Setup Time	20ns	–
t_{SAH}	Address Hold Time after /IOR or /IOW High	20ns	–
t_{RD}	Read Time	$2 \times t_{CLK}$	∞
t_{WR}	Write Time	$2 \times t_{CLK}$	∞
t_{WRDSU}	Write Data Setup Time to /IOW Low	25ns	∞
t_{WRDH}	Write Data Hold Time from /IOW High	10ns	–
t_{RDY}	Delay Time from /IOR or /IOW Low to IOCHRDY Low	3ns	30ns
t_{RDYH}	Delay Time from /IOR Low or /IOW High to IOCHRDY High	3ns	30ns
t_{BUSRD}	Delay Time from /IOR Low to BUSDIR Low	3ns	25ns

SYMBOL	CHARACTERISTICS	MIN.	MAX.
t_{SRDH}	Data Out Stable Hold Time after Clock \uparrow	5ns	–
t_{SRDSU}	Data In Setup Time to Clock \uparrow	20ns	–
t_{SRDHR}	Data In Hold Time after Clock \uparrow	0ns	–
t_{SRWR}	Delay Time Clock \uparrow to /SRWR Low	2ns	40ns
t_{SRWRH}	Delay Time Clock \uparrow to /SRWR High	5ns	40ns
t_{SRWRA}	Data and Address Hold Time after /SRWR \uparrow	1ns	–

*) Clock should be symmetrical so $t_{LOW} = t_{HIGH}$

6.3 GCI/IOM timing

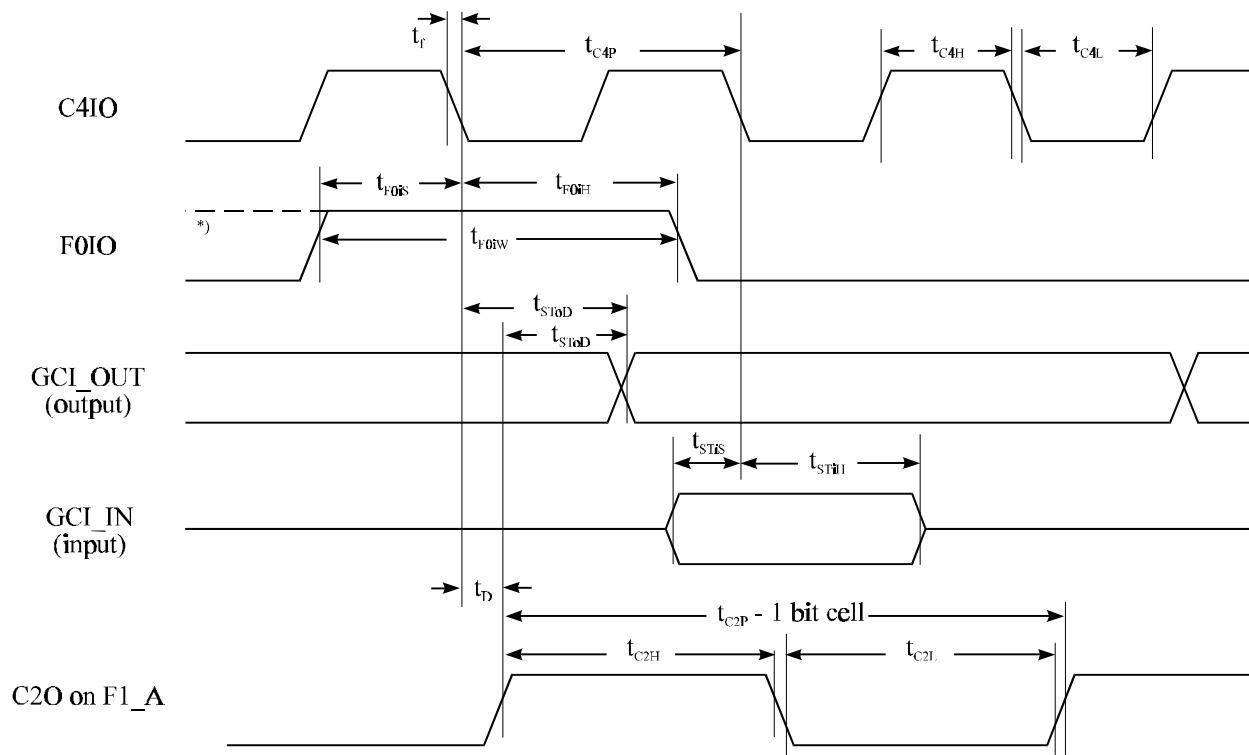

Timing Diagram 3: GCI/IOM timing

*) F0IO starts one C4IO clock earlier if bit 3 in MST_MODE register is set. If this bit is set F0IO is also awaited one C4IO clock cycle earlier.

SYMBOL	CHARACTERISTICS	MIN.	MAX
t _{C4P}	Clock C4IO period (4.096 MHz)	243.9 ns	244.4 ns
t _{C4H}	Clock C4IO High Width	110 ns	134 ns
t _{C4L}	Clock C4IO Low Width	110 ns	134 ns
t _{C2P}	Clock C2O Period	487.8 ns	488.8 ns
t _{C2H}	Clock C2O High Width	220 ns	268 ns
t _{F0iS}	F0IO Setup Time	50 ns	150 ns
t _{F0iH}	F0IO Hold Time	50 ns	150 ns
t _{F0iW}	F0IO Width	200 ns	300 ns
t _{SToD}	GCI_IN Delay Level 1 Output	20 ns	125 ns
t _{SToD}	GCI_IN Delay Level 2 Output	20 ns	125 ns
t _{STiS}	GCI_OUT Set Up Time	30 ns	
t _{STiH}	GCI_OUT Hold Time	2 ns	30ns

All specifications are for 2.048 Mb/s Streams and $f_{CLK} = 12.288$ Mhz.

7 GCI frame structure

The binary organisation of a single GCI channel frame is described below.

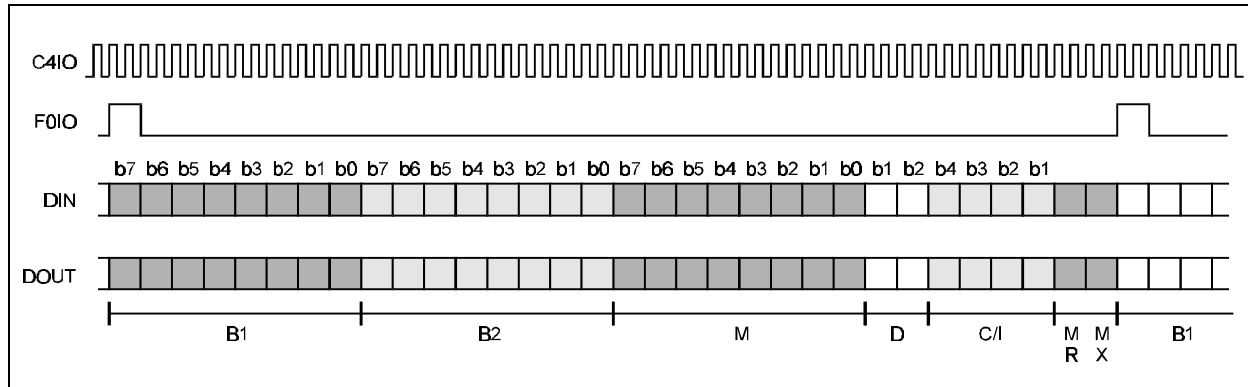

Figure 7: Single channel GCI format

- B1 B-channel 1 data
- B2 B-channel 2 data
- M Monitor channel data
- D D-channel data
- C/I Command/indication bits for controlling activation/deactivation and for additional control functions
- MR Handshake bit for monitor channel
- MX Handshake bit for monitor channel

8 HFC-U package dimensions

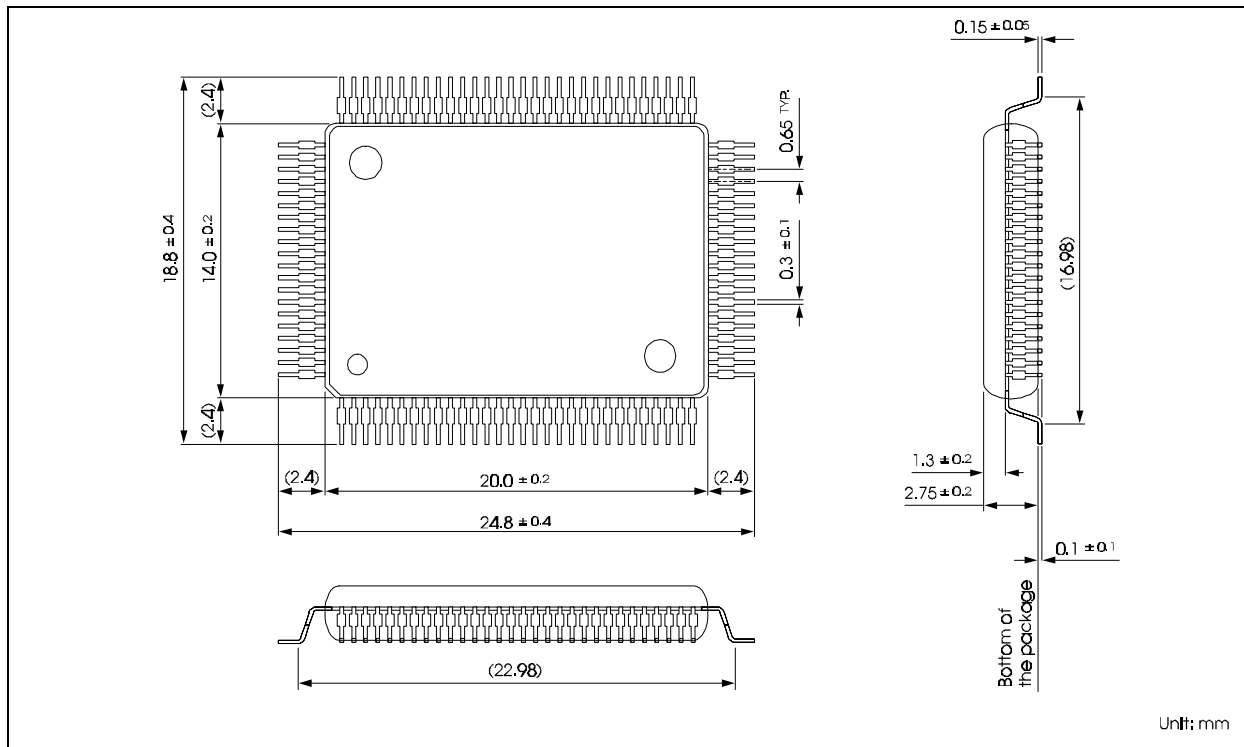
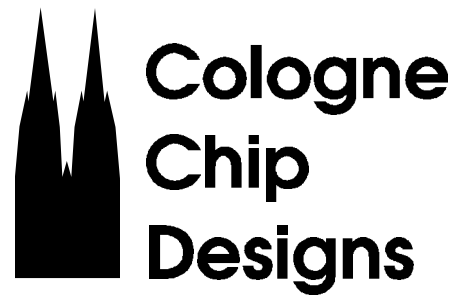

Figure 8: HFC-U package dimensions



**Eintrachtstrasse 113
D-50668 Köln
Germany**

**Tel.: +49 (0) 221 / 912 96 04
Fax: +49 (0) 221 / 912 90 98
<http://www.ccd.kud.com>
colognechip@t-online.de**