

## 1°C Triple Temperature Sensor with Resistance Error Correction & Hotter of Two Zones

### PRODUCT FEATURES

Datasheet

#### General Description

The EMC1053 is a System Management Bus (SMBus) temperature sensor that monitors three temperature zones, one internal diode and two externally connected diodes, for PC and embedded environments. The EMC1053 includes resistance error correction and ideality factor configuration to eliminate major sources of temperature measurement error.<sup>1</sup>

An added feature to the EMC1053 is a function that automatically compares the two external temperature zones and reports the hotter of the two temperatures. Selectable conversion rates and standby mode support low-power operation. The temperature measurement ranges support two data ranges (and formats), -64°C to +127°C and -64°C to +191°C.

#### Applications

- Desktop and Notebook Computers
- Hardware Management
- Servers
- Embedded Applications

#### Features

- Supports two External Temperature Diodes
  - ±1°C Accuracy (40°C to 80°C)
  - 0.125°C Resolution
  - Ideality Factor Configuration
  - Accepts 2200pF Cap Across External Diodes for Noise Suppression
  - Optional Resistive Error Correction on External Diode 2
  - Resistance Error Correction (up to 100 Ohms)
  - Selectable Beta Compensation for Substrate Diodes
- Internal Temperature Diode
  - ±3°C Accuracy (0°C to 85°C)
  - 0.125°C Resolution
- Low Power Operation
  - 4uA Standby Current
- 3.0V to 3.6V Supply
- Programmable Conversion Rate
- SMBus 2.0 Compliant
- Reports Hotter of Two Diodes with Dual-core CPU

1. Patents pending.

#### Simplified Block Diagram

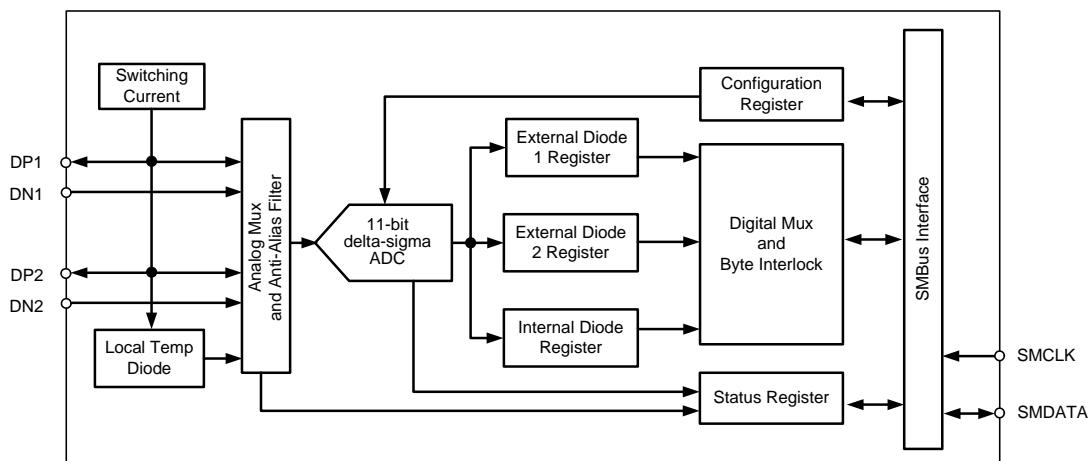

**ORDERING INFORMATION**

ORDERING NUMBER	PACKAGE	FEATURES	SMBUS ADDRESS
EMC1053-1-ACZL-TR	8 pinMSOP package (Lead Free ROHS compliant)	Two external diodes with REC	1001_100x
EMC1053-2-ACZL-TR			1001_101x
EMC1053-3-ACZL-TR			1001_000x
EMC1053-4-ACZL-TR			1001_001x

Reel size is 4,000 pieces.

Evaluation Boards available upon request. (EVB-EMC1053, EVB-EMC1053C)



80 ARKAY DRIVE, HAUPPAUGE, NY 11788 (631) 435-6000, FAX (631) 273-3123

Copyright © 2008 SMSC or its subsidiaries. All rights reserved.

Circuit diagrams and other information relating to SMSC products are included as a means of illustrating typical applications. Consequently, complete information sufficient for construction purposes is not necessarily given. Although the information has been checked and is believed to be accurate, no responsibility is assumed for inaccuracies. SMSC reserves the right to make changes to specifications and product descriptions at any time without notice. Contact your local SMSC sales office to obtain the latest specifications before placing your product order. The provision of this information does not convey to the purchaser of the described semiconductor devices any licenses under any patent rights or other intellectual property rights of SMSC or others. All sales are expressly conditional on your agreement to the terms and conditions of the most recently dated version of SMSC's standard Terms of Sale Agreement dated before the date of your order (the "Terms of Sale Agreement"). The product may contain design defects or errors known as anomalies which may cause the product's functions to deviate from published specifications. Anomaly sheets are available upon request. SMSC products are not designed, intended, authorized or warranted for use in any life support or other application where product failure could cause or contribute to personal injury or severe property damage. Any and all such uses without prior written approval of an Officer of SMSC and further testing and/or modification will be fully at the risk of the customer. Copies of this document or other SMSC literature, as well as the Terms of Sale Agreement, may be obtained by visiting SMSC's website at <http://www.smisc.com>. SMSC is a registered trademark of Standard Microsystems Corporation ("SMSC"). Product names and company names are the trademarks of their respective holders.

**SMSC DISCLAIMS AND EXCLUDES ANY AND ALL WARRANTIES, INCLUDING WITHOUT LIMITATION ANY AND ALL IMPLIED WARRANTIES OF MERCHANTABILITY, FITNESS FOR A PARTICULAR PURPOSE, TITLE, AND AGAINST INFRINGEMENT AND THE LIKE, AND ANY AND ALL WARRANTIES ARISING FROM ANY COURSE OF DEALING OR USAGE OF TRADE. IN NO EVENT SHALL SMSC BE LIABLE FOR ANY DIRECT, INCIDENTAL, INDIRECT, SPECIAL, PUNITIVE, OR CONSEQUENTIAL DAMAGES; OR FOR LOST DATA, PROFITS, SAVINGS OR REVENUES OF ANY KIND; REGARDLESS OF THE FORM OF ACTION, WHETHER BASED ON CONTRACT; TORT; NEGLIGENCE OF SMSC OR OTHERS; STRICT LIABILITY; BREACH OF WARRANTY; OR OTHERWISE; WHETHER OR NOT ANY REMEDY OF BUYER IS HELD TO HAVE FAILED OF ITS ESSENTIAL PURPOSE, AND WHETHER OR NOT SMSC HAS BEEN ADVISED OF THE POSSIBILITY OF SUCH DAMAGES.**

## Table of Contents

<b>Chapter 1</b>	<b>Pin Function</b>	<b>6</b>
<b>Chapter 2</b>	<b>Electrical Specifications</b>	<b>7</b>
2.1	Absolute Maximum Ratings	7
2.2	Electrical Specifications	7
2.3	System Management Bus Interface Protocol	9
2.3.1	Write Byte	9
2.3.2	Read Byte	9
2.3.3	Send Byte	10
2.3.4	Receive Byte	10
2.3.5	SMBus Timing Diagram	10
2.4	SMBus Addresses	10
2.5	SMBus Timeout	10
<b>Chapter 3</b>	<b>Product Description</b>	<b>11</b>
3.1	Power Modes	11
3.2	One Shot During Standby Mode	11
3.3	Operation During Run Mode	11
3.3.1	Conversion Rates	12
3.3.2	Dynamic Averaging	12
3.4	Temperature Monitors	12
3.5	Temperature Measurement Results and Data	14
3.6	Resistance Error Correction (REC)	14
3.7	Beta Compensation	15
3.8	Programmable Ideality Factor	15
3.9	Diode Faults	15
<b>Chapter 4</b>	<b>Register Set and Description</b>	<b>16</b>
4.1	Legacy Temperature Data Registers (00h, 23h, 01h, 10h, F8h, F9h)	18
4.2	Extended Format Temperature Registers (FAh-FDh)	18
4.3	Status Register - 02h	19
4.4	Configuration Register (03h Read, 09h Write)	19
4.5	Configuration 2 Register - (04h)	20
4.6	One Shot Register - (0Fh)	21
4.7	Ideality Configuration Registers (27h - 28h)	21
4.8	Beta Configuration Registers (29h - 2Ah)	23
4.9	Product ID Register (EDh)	24
4.10	Manufacturer ID Register (FEh)	24
4.11	Revision Register (FFh)	24
<b>Chapter 5</b>	<b>Typical Operating Curves</b>	<b>25</b>
<b>Chapter 6</b>	<b>Package Outline</b>	<b>27</b>
6.1	Package Markings	28

## List of Figures

Figure 1.1	EMC1053 Pin Diagram	6
Figure 2.1	System Management Bus Timing Diagram	9
Figure 3.1	EMC1053 Diode System	11
Figure 3.2	Block Diagram of Temperature Monitoring Circuit	13
Figure 3.3	External Diode Configurations	13
Figure 6.1	8-Pin MSOP Package Outline - 3x3mm Body 0.65mm Pitch	27

## List of Tables

Table 1.1	EMC1053 Pin Description	6
Table 2.1	Absolute Maximum Ratings	7
Table 2.2	Electrical Characteristics	7
Table 2.3	Write Byte Protocol	9
Table 2.4	Read Byte Protocol	9
Table 2.5	Send Byte Protocol	10
Table 2.6	Receive Byte Protocol	10
Table 3.1	Supply Current vs. Conversion Rate and ADC Averaging Factor	12
Table 3.2	EMC1053 Temperature Data Format	14
Table 4.1	EMC1053 Register Set	16
Table 4.2	Status Register	19
Table 4.3	Configuration Register	19
Table 4.4	Conversion Rate	20
Table 4.5	Configuration 2 Register	20
Table 4.6	One Shot Registers	21
Table 4.7	Ideality Configuration Registers	21
Table 4.8	Ideality Factor Look Up Table	22
Table 4.9	Substrate Diode Ideality Factor Look-Up Table (BJT Model)	22
Table 4.10	Beta Configuration Registers	23
Table 4.11	Beta Configuration Look Up Table	23
Table 4.12	Product ID Register	24
Table 4.13	Manufacturer ID Register	24
Table 4.14	Revision Register	24
Table 6.1	8-Pin MSOP Package Parameters	27

## Chapter 1 Pin Function

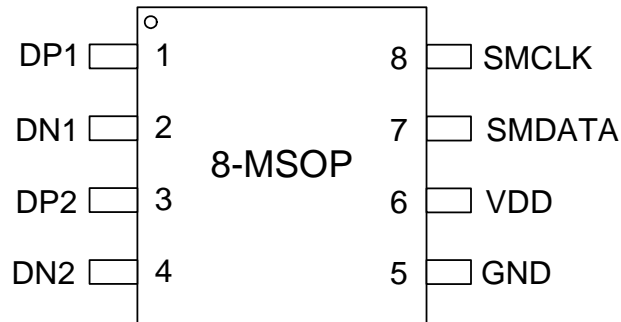

**Figure 1.1 EMC1053 Pin Diagram**

**Table 1.1 EMC1053 Pin Description**

PIN	PIN NO.	DESCRIPTION
DP1	1	External Diode 1 Positive (anode) Connection
DN1	2	External Diode 1 Negative (cathode) Connection
DP2	3	External Diode 2 Positive (anode) Connection
DN2	4	External Diode 2 Negative (cathode) Connection
GND	5	Ground
VDD	6	Supply Voltage
SMDATA	7	System Management Bus Data - bi-directional data, open drain output
SMCLK	8	System Management Bus Clock Input

## Chapter 2 Electrical Specifications

### 2.1 Absolute Maximum Ratings

Table 2.1 Absolute Maximum Ratings

DESCRIPTION	RATING	UNIT
Supply Voltage $V_{DD}$	-0.3 to 5.0	V
Voltage on SMDATA and SMCLK pins	-0.3 to 5.5	V
Voltage on any other pin	-0.3 to $V_{DD}+0.3$	V
Operating Temperature Range	-40 to 125	°C
Storage Temperature Range	-55 to 150	°C
Lead Temperature Range	Refer to JEDEC Spec. J-STD-020	
Package Thermal Characteristics for MSOP-8		
Thermal Resistance $T_{JA}$ (at 0 air flow)	135.9	°C/W
ESD Rating, All Pins Human Body Model	2000	V

**Note:** Stresses above those listed could cause damage to the device. This is a stress rating only and functional operation of the device at any other condition above those indicated in the operation sections of this specification is not implied. When powering this device from laboratory or system power supplies, it is important that the Absolute Maximum Ratings not be exceeded or device failure can result. Some power supplies exhibit voltage spikes on their outputs when the AC power is switched on or off. In addition, voltage transients on the AC power line may appear on the DC output. If this possibility exists, it is suggested that a clamp circuit be used.

### 2.2 Electrical Specifications

Table 2.2 Electrical Characteristics

$V_{DD}=3.0V$ to $3.6V$ , $T_A = -20^\circ C$ to $+85^\circ C$ , Typical values at $T_A = 27^\circ C$ unless otherwise noted						
PARAMETER	SYMBOL	MIN	TYP	MAX	UNITS	CONDITIONS
<b>DC Power</b>						
Supply Voltage	$V_{DD}$	3.0	3.3	3.6	V	
Average Operating Current	$I_{DD}$		340	400	$\mu A$	4 conversions/s See <a href="#">Table 4.4</a> .
	$I_{STBY}$		2	4	$\mu A$	Standby mode
<b>Internal Temperature Monitor</b>						
Temperature Accuracy			$\pm 1$	$\pm 3$	°C	$-20^\circ C \leq T_A \leq 85^\circ C$
				$\pm 1.5$	°C	$0^\circ C < T_A \leq 85^\circ C$
Temperature Resolution			0.125		°C	

**Table 2.2 Electrical Characteristics (continued)**

V <sub>DD</sub> =3.0V to 3.6V, T <sub>A</sub> = -20°C to +85°C, Typical values at T <sub>A</sub> = 27°C unless otherwise noted						
PARAMETER	SYMBOL	MIN	TYP	MAX	UNITS	CONDITIONS
<b>External Temperature Monitor</b>						
Temperature Accuracy Remote Diode 40°C to 80°C Remote Diode -20°C to 125°C Remote Diode -64°C to 192°C				± 1 ± 3 ± 5	°C °C °C	15°C ≤ T <sub>A</sub> ≤ 70°C -20°C ≤ T <sub>A</sub> ≤ 85°C -20°C ≤ T <sub>A</sub> ≤ 85°C
Temperature Resolution			0.125		°C	
Filter Capacitor	C <sub>FILTER</sub>			2.2	nF	Connected across external diode <a href="#">Note 2.2</a>
<b>Voltage Tolerance</b>						
Voltage at pin ( SMDATA,SMCLK)	V <sub>TOL</sub>	-0.3		5.5	V	
<b>SMBus Interface (SMDATA,SMCLK)</b>						
Input High Level	V <sub>IH</sub>	2.0			V	
Input Low Level	V <sub>IL</sub>			0.8	V	
Input High/Low Current	I <sub>IH</sub> /I <sub>IL</sub>	-1		1	μA	
Hysteresis			500		mV	
Input Capacitance			5		pF	
Output Low Sink Current		6			mA	SMDATA = 0.6V
<b>SMBus Timing</b>						
Clock Frequency	F <sub>SMB</sub>	10		400	kHz	
Spike Suppression				50	ns	
Bus free time Start to Stop	T <sub>BUF</sub>	1.3			μs	
Hold time Start	T <sub>HD:STA</sub>	0.6			μs	
Setup time Start	T <sub>SU:STA</sub>	0.6			μs	
Setup time Stop	T <sub>SU:STO</sub>	0.6			μs	
Data Hold Time	T <sub>HD:DAT</sub>	0.3			μs	
Data Setup Time	T <sub>SU:DAT</sub>	100			ns	
Clock Low Period	T <sub>LOW</sub>	1.3			μs	
Clock High Period	T <sub>HIGH</sub>	0.6			μs	
Clock/Data Fall Time	T <sub>F</sub>	*		300	ns	*Min = 20+0.1C <sub>b</sub> ns
Clock/Data Rise Time	T <sub>R</sub>	*		300 <a href="#">Note 2.1</a>	ns	*Min = 20+0.1C <sub>b</sub> ns
Capacitive Load (each bus line)	C <sub>b</sub>	0.6		400	pF	

Datasheet

- Note 2.1** 300nS rise time max is required for 400kHz bus operation. For lower clock frequencies, the maximum rise time is  $(0.1/F_{SMB})+50nS$
- Note 2.2** See SMSC Applications for Application Notes and Guidelines when measuring GPU processor diodes and CPU processor diodes.

## 2.3 System Management Bus Interface Protocol

A host controller, such as an SMSC I/O controller, communicates with the EMC1053 via the two wire serial interface named SMBus. The SMBus interface is used to read and write registers in the EMC1053, which is a slave-only device. A detailed timing diagram is shown in [Figure 2.1](#).

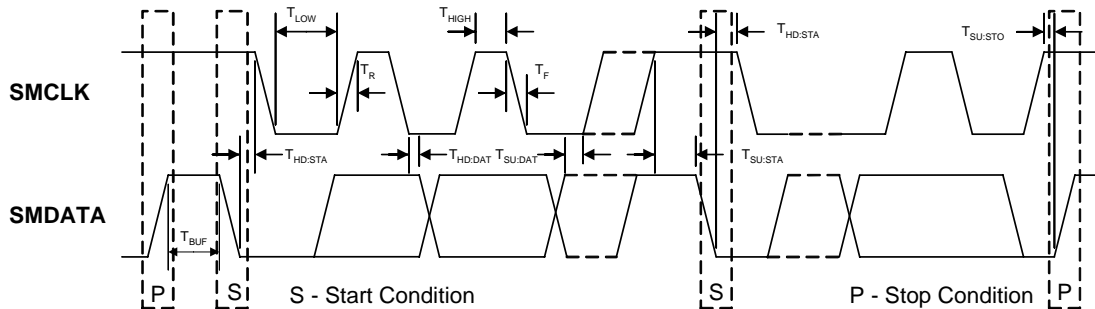

**Figure 2.1 System Management Bus Timing Diagram**

The EMC1053 implements a subset of the SMBus specification and supports Write Byte, Read Byte, Send Byte, and Receive Byte protocols as shown. In the tables that describe the protocol, the “gray” columns indicate that the slave is driving the bus.

All of the below protocols use the following convention:

DATA SENT TO DEVICE	DATA SENT TO THE HOST
# of bits sent	# of bits sent

### 2.3.1 Write Byte

The Write Byte is used to write one byte of data to the registers as shown in [Table 2.3](#).

**Table 2.3 Write Byte Protocol**

START	SLAVE ADDRESS	WR	ACK	COMMAND	ACK	DATA	ACK	STOP
1	7	1	1	8	1	8	1	1

### 2.3.2 Read Byte

The Read Byte protocol is used to read one byte of data from the registers as shown in [Table 2.4](#).

**Table 2.4 Read Byte Protocol**

START	SLAVE ADDRESS	WR	ACK	COMMAND	ACK	START	SLAVE ADDRESS	RD	ACK	DATA	NACK	STOP

**Table 2.4 Read Byte Protocol**

1	7	1	1	8	1	1	7	1	1	8	1	1
---	---	---	---	---	---	---	---	---	---	---	---	---

### 2.3.3 Send Byte

The Send Byte protocol is used to set the Internal Address Register to the correct Address as shown in [Table 2.5](#). The Send Byte can be followed by the Receive Byte protocol described in [Table 2.6](#) to read data from the register. The send byte protocol cannot be used to write data - if data is to be written to a register then the write byte protocol must be used as described in [Section 2.3.1](#).

**Table 2.5 Send Byte Protocol**

START	SLAVE ADDR	WR	ACK	REG. ADDR	ACK	STOP
1	7	1	1	8	1	1

### 2.3.4 Receive Byte

The Receive Byte protocol is used to read data from a register when the internal register address pointer is known to be at the right location (e.g. set via Send Byte). This can be used for consecutive reads of the same register as shown in [Table 2.6](#).

**Table 2.6 Receive Byte Protocol**

START	SLAVE ADDR	RD	ACK	REG. DATA	NACK	STOP
1	7	1	1	8	1	1

### 2.3.5 SMBus Timing Diagram

The Timing for the SMBus is shown in [Figure 2.1](#).

## 2.4 SMBus Addresses

The EMC1053 may be ordered with one of four slave addresses as shown in [Ordering Information](#). Attempting to communicate with the EMC1053 SMBus interface with an invalid slave address or invalid protocol results in no response from the device and does not affect its register contents. The EMC1053 supports stretching of the SMCLK signal by other devices on the SMBus but will not perform this operation itself.

## 2.5 SMBus Timeout

The EMC1053 includes an SMBus time-out feature. Following a 25 ms period of inactivity on the SMBus, the device will time-out and reset the SMBus interface.

## Chapter 3 Product Description

The EMC1053 is an SMBus sensor that monitors three temperature zones for use in a personal computer or embedded environment. The part may be used as a companion to one of SMSC's broad line of SIO host devices to perform fan control and thermal management.

A typical system drawing of the EMC1053 is shown in [Figure 3.1](#).

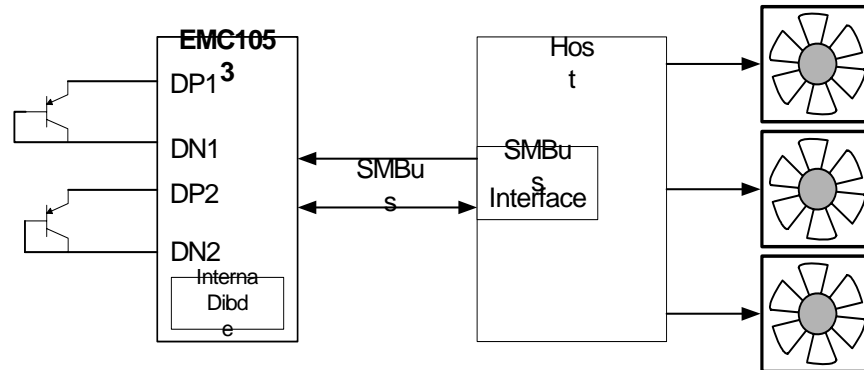

Figure 3.1 EMC1053 Diode System

### 3.1 Power Modes

The EMC1053 has two power modes.

- Run Mode - In this mode, the temperature monitors are active and converting at the programmed conversion rate. The average power dissipation will depend on the conversion rate. When the EMC1053 is not actively converting a channel, it goes into a lower power wait state.
- Standby Mode (power-up default) - in this mode, the EMC1053 is put into a low power state. In the standby mode, temperature monitoring is disabled. The device will still respond to SMBus commands.

### 3.2 One Shot During Standby Mode

The EMC1053 supports a One-Shot command when it is in Standby Mode. Writing to the One-Shot register will cause the device to power up, perform 1 full set of temperature conversions, then return to Standby Mode.

### 3.3 Operation During Run Mode

When the device is active, there are two modes of operation available.

- Normal Mode (power-up default) - In this mode of operation, the EMC1053 continuously samples and updates all of its temperature channels.
- Hotter of Two Mode - In this mode, the EMC1053 continuously samples and then compares the two remote zones. The hotter of the two remote zones is loaded into the External Diode 2 Data Registers. In addition, the HOTTER bit in the Status register is set or cleared to indicate which external diode zone is hotter. If the two remote zones are exactly equal to each other, then the HOTTER bit is cleared (set to '0'), and the results of the two remote zones are stored in their respective registers.

### 3.3.1 Conversion Rates

The EMC1053 may be configured for different conversion rates based on the system requirements. The available rates are 1 full set of conversions per second to 16 full sets of conversions per second. The conversion rate is configured as described in [Section 4.4](#). The available conversion rates are shown in [Table 4.4](#).

### 3.3.2 Dynamic Averaging

The EMC1053 temperature channels support a new feature that measures the external diode channels for an extended time based on the selected conversion rate. This functionality can be disabled as described in [Section 4.5](#) for increased power savings at the lower conversion rates. When Dynamic Averaging is enabled, the device will automatically adjust the sampling and measurement time for both external diode channels. This allows the device to average 2x or 4x longer than the normal 11 bit operation while still maintaining the selected conversion rate. The benefits of Dynamic Averaging are improved noise rejection due to the longer integration time as well as less random variation on the temperature measurement.

The Dynamic Averaging applies when a One-Shot command is issued. The device will perform the desired averaging during the one-shot operation according to the selected conversion rate.

The Dynamic Averaging will affect the average supply current based on the chosen conversion rate as shown in [Table 3.1](#).

**Table 3.1 Supply Current vs. Conversion Rate and ADC Averaging Factor**

CONVERSION RATE	ADC AVERAGING FACTOR		
	4X (MAX_RES = 1) (DA_N = 0)	2X (MAX_RES = 0) (DA_N = 0)	1X (DA_N = 1)
1 / sec	190uA	132uA	105uA
2 / sec	315uA	205uA	150uA
4 / sec	580uA	350uA	235uA
8 / sec	N/A	640uA	405uA
16 / sec	N/A	N/A	750uA

## 3.4 Temperature Monitors

In general, thermal diode temperature measurements are based on the change in forward bias voltage of a diode when operated at two different currents. This  $\Delta V_{BE}$  is then proportional to absolute temperature as shown in the following equation:

$$\Delta V_{BE} = V_{BE\_HIGH} - V_{BE\_LOW} = \frac{\eta k T}{q} \ln \left( \frac{I_{HIGH}}{I_{LOW}} \right)$$

where:

$k$  = Boltzmann's constant

$T$  = absolute temperature in Kelvin [1]

$q$  = electron charge

$\eta$  = diode ideality factor

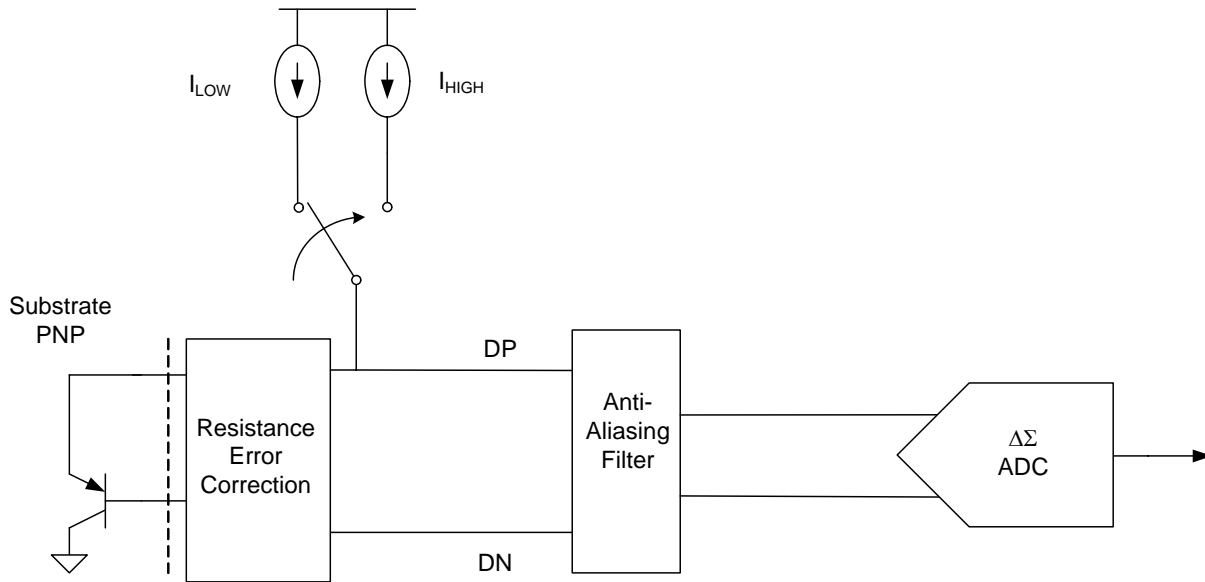

**Figure 3.2 Block Diagram of Temperature Monitoring Circuit**

Figure 3.2 shows a block diagram of the temperature measurement circuit. The negative terminal for the remote temperature diode, DN, is internally biased with a forward diode voltage referenced to ground.

The external diodes in the EMC1053 are compatible with a broad range of thermal diodes that may be connected as shown in Figure 3.3.

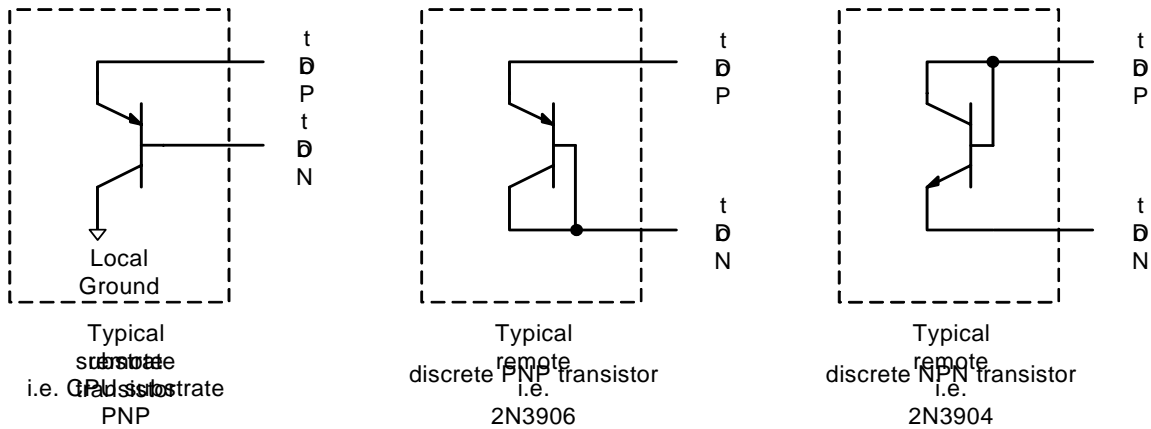

**Figure 3.3 External Diode Configurations**

### 3.5 Temperature Measurement Results and Data

Each temperature result for each zone is available in two byte wide data registers. As shown in [Section 4.1](#), the 11-bit format has the 8 most significant bits stored in the high byte register and the 3 least significant bits stored in the three MSB positions of the low byte register. The delta-sigma ADC may be operated with more than 11 bits of resolution for improved averaging as described in [Section 4.5](#), but the temperature result is reported at 11-bit resolution.

The temperature results for the two remote zones are also stored in extended format with a range from -64°C to +191°C. The data format is a 2's complement number offset by 64°C as shown in [Section 4.2](#). The data for each of the remote zones in both legacy and extended format is stored in separate data registers so that both data formats are always available. [Table 3.2](#) shows the default and extended range formats.

**Table 3.2 EMC1053 Temperature Data Format**

TEMPERATURE (°C)	RANGE -64°C TO 127°C	RANGE -64°C TO 191°C
	BINARY	OFFSET BINARY
Diode Fault	100 0000 0000	100 0000 0000
<= -64	110 0000 0000	100 0000 0000
-63.875	110 0000 0001	100 0000 0001
-63	110 0000 1000	100 0000 1000
-1	111 1111 1000	101 1111 1000
0	000 0000 0000	110 0000 0000
0.125	000 0000 0001	110 0000 0001
1	000 0000 1000	110 0000 1000
64	010 0000 0000	000 0000 0000
65	010 0000 1000	000 0000 1000
127	011 1111 1000	001 1111 1000
127.875	011 1111 1111	001 1111 1111
128	011 1111 1111	010 0000 0000
191	011 1111 1111	011 1111 1000
>= 191.875	011 1111 1111	011 1111 1111

### 3.6 Resistance Error Correction (REC)

Resistance error correction is an automatic feature that eliminates the need to characterize and compensate for series resistance in the external diode lines. The EMC1053 corrects for as much as 100 ohms of series resistance.

When using a temperature sensor that does not include resistance error correction, voltage developed across the parasitic resistance in the external diode path produces an error in the reported temperature. The error introduced by this resistance is approximately +0.7°C per ohm. Sources of series resistance are PCB trace resistance, on die (i.e. on the processor) metal resistance, bulk resistance in the base and emitter of the temperature transistor.

## Datasheet

When monitoring the thermal diode of an AMD K8 processor, the Resistance Error Correction must be disabled for accurate temperature measurements. This is accomplished by clearing the REC bit in the configuration 2 register (see [Section 4.5](#)). Please see Application note “13.16 - Using the EMC1043 with AMD Processors” for more details.

### 3.7 Beta Compensation

The Beta Compensation function can be programmed to eliminate temperature errors caused by beta variation in modern, low beta transistors used for monitoring processor temperatures. Changes in beta as differing currents are applied to temperature transistors can cause significant temperature errors in monitoring devices. As modern processor geometries shrink the trend is for transistor betas to decrease, which exacerbates temperature errors.

By default, this functionality is disabled. It can be enabled by writing any value other than 07h in the Beta Configuration Registers (see [Section 4.11](#)).

Discrete transistors, with collector connected to base to form a diode, are generally immune to these temperature errors because of high (>100) betas. A beta variation of 10% from low current to high current, when beta equals 100, induces approximately 0.12° error at 100°C. However for a low beta (1.0) substrate transistor used for processor temperature measurement, a beta variation of 10% from low to high current induces approximately 6.12° error at 100°C.

When measuring an AMD K8 processor, the Beta Compensation circuitry must be disabled. See [Section 4.8](#). Please see SMSC Application note “13.16 - Using the EMC1043 with AMD Processors” for more details.

### 3.8 Programmable Ideality Factor

The EMC1053 default is for a diode ideality factor of 1.008 which is common for a 2N3904 diode and for many processor transistors. When a diode or transistor is used that has a different ideality factor value than 1.008 a temperature error is induced that is a linear function of temperature. Previous solutions for this mismatch in ideality factor has been to supply a programmable offset to the temperature reading which corrects the error at a single temperature but causes a residual error at all other temperatures. The EMC1053 ideality factor register corrects this mismatch error at all temperatures (see [Section 4.7](#)).

**APPLICATION NOTE:** When monitoring a substrate transistor or CPU diode and beta compensation is enabled, the Ideality Factor should not be adjusted. Beta Compensation automatically corrects for most ideality errors.

### 3.9 Diode Faults

The EMC1053 detects a fault if the DP pin is left floating or is shorted to VDD. In the case of a diode fault, the corresponding status bit will be set and the output data will be set at 400h.

## Chapter 4 Register Set and Description

The following registers are accessible through the SMBus Interface.

**Table 4.1 EMC1053 Register Set**

REGISTER ADDRESS		R/W	REGISTER NAME	SYMBOL	B7	B6	B5	B4	B3	B2	B1	B0	DEFAULT VALUE
READ	WRITE												
00h	N/A	R	Internal Temperature High Byte - Legacy Format	INTHBL	Sign	64	32	16	8	4	2	1	00h
23h	N/A	R	Internal Temperature Low Byte - Legacy Format	INTLBL	0.5	0.25	0.125						00h
01h	N/A	R	External Diode 1 High Byte - Legacy Format	ET1HBL	Sign	64	32	16	8	4	2	1	00h
10h	N/A	R	External Diode 1 Low Byte - Legacy Format	ET1LBL	0.5	0.25	0.125						00h
F8h	N/A	R	External Diode 2 High Byte - Legacy Format	ET2HBL	Sign	64	32	16	8	4	2	1	00h
F9h	N/A	R	External Diode 2 Low Byte - Legacy Format	ET2LBL	0.5	0.25	0.125						00h
FAh	N/A	R	External Diode 1 High Byte - Extended Format	ET1HBE	128	64	32	16	8	4	2	1	00h
FBh	N/A	R	External Diode 1 Low Byte - Extended Format	ET1LBE	0.5	0.25	0.125						00h
FCh	N/A	R	External Diode 2 High Byte - Extended Format	ET2HBE	128	64	32	16	8	4	2	1	00h

**Table 4.1 EMC1053 Register Set (continued)**

REGISTER ADDRESS		R/W	REGISTER NAME	SYMBOL	B7	B6	B5	B4	B3	B2	B1	B0	DEFAULT VALUE
READ	WRITE												
FDh	N/A	R	External Diode 2 Low Byte - Extended Format	ET2LBE	0.5	0.25	0.125						00h
Status and Control													
02h	N/A	R	Status	STS	Busy	-	-	HOTTER	-	-	D2	D1	00h
03h	09h	R/W	Configuration	CFG	-	ADC_STOP	-	-	-	CR<2:0>			45h
04h	04h	R/W	Configuration 2	CFG2	-	-	-	-	MAX_RES	DA_n	COMP	REC	09h
One Shot													
N/A	0Fh	W	One Shot Conversion	Shot	The data written to this register is irrelevant and will not be stored							00h	
Ideality													
27h	27h	R/W	External Diode 1 Ideality Correction Factor	IDCF1	-	-	B5	B4	B3	B2	B1	B0	12h (1.008)
28h	28h	R/W	External Diode 2 Ideality Correction Factor	IDCF2	-	-	B5	B4	B3	B2	B1	B0	12h (1.008)
29h	29h	R/W	External Diode 1 Beta Configuration	BCF1	-	-	-	-	-	BETA<2:0>			07h

Table 4.1 EMC1053 Register Set (continued)

REGISTER ADDRESS		R/W	REGISTER NAME	SYMBOL	B7	B6	B5	B4	B3	B2	B1	B0	DEFAULT VALUE
READ	WRITE												
2Ah	2Ah	R/W	External Diode 2 Beta Configuration	BCF2	-	-	-	-	-	BETA<2:0>			07h
EDh	EDh	R	Product ID	PID	0	0	1	1	1	1	0	0	3Ch (-1)
					0	0	1	1	1	1	0	1	3Dh (-2)
					0	0	1	1	1	1	1	0	3Eh (-3)
					0	0	1	1	1	1	1	1	3Fh (-4)
FEh	FEh	R	Manufacturer ID	SMSC	0	1	0	1	1	1	0	1	5Dh
FFh	FFh	R	Revision Register	REV	-	-	-	-	0	0	0	1	01h

During Power on Reset (POR), the default values are stored in the registers. A POR is initiated when power is first applied to the part and the voltage on the VDD supply surpasses the POR level as specified in the electrical characteristics. Any reads to undefined registers will return 00h. Writes to undefined registers will not have an effect.

The EMC1053 uses an interlock mechanism that will update the Low byte of a particular monitor when the High Byte is read. This prevents changes in register content when the ADC updates between successive reads.

## 4.1 Legacy Temperature Data Registers (00h, 23h, 01h, 10h, F8h, F9h)

As shown in [Table 4.1](#), each temperature monitor has two data registers. The 11 bit temperature data is stored aligned to the left resulting in the High Byte containing temperature in 1°C steps and the Low Byte containing fractions of a degree.

## 4.2 Extended Format Temperature Registers (FAh-FDh)

The Extended Format Temperature Registers store only the external diode temperatures in the extended data format. This is because, due to the operating range limitations of the EMC1053, the internal temperature could not benefit from the extended temperature range. Like the Legacy data formatting, the data is stored in two registers per temperature channel.

## 4.3 Status Register - 02h

Table 4.2 Status Register

ADDR	REGISTER	B7	B6	B5	B4	B3	B2	B1	B0	DEFAULT
02h	Status	Busy	-	-	HOTTER	-	-	D2	D1	00h

The Status Register is a read only register and returns the operational status of the part. External diode faults are indicated by bits 1 and 0. If either bit is set to '1', then a diode fault has occurred. When a diode fault occurs, the D1 or D2 status bit is set, but otherwise the data remains unchanged.

Bit 7 - Busy - indicates that the ADC is currently converting a temperature.

Bit 4 - HOTTER - during Hotter of Two mode, this bit indicates which of the external diode channels is hotter. If this bit is '0', then External Diode 1 is hotter or equal to External Diode 2. If this bit is '1', then External Diode 2 is hotter than External Diode 1. During normal operation, this bit will always read a '0'.

Bit 1 - D2 - indicates that a diode fault has occurred on External Diode 2.

Bit 0 - D1 - indicates that a diode fault has occurred on External Diode 1.

## 4.4 Configuration Register (03h Read, 09h Write)

Table 4.3 Configuration Register

ADDR	REGISTER	B7	B6	B5	B4	B3	B2	B1	B0	DEFAULT
03h Read, 09h Write	Config	-	STANDBY	-	-	-	CR<2:0>			45h

The Configuration Register controls the basic functionality of the EMC1053. The bits are described below:

Bit 6 - STANDBY- controls the ADC conversions and power modes of the part.

- '0' - The device is in the run operating mode. The ADC is converting at the user-programmed conversion rate.
- '1' - (default) The device is in the standby operating mode (see [Section 3.1](#)).

Bit 2-0 - CR<2:0> - determines the conversion rate for the temperature monitoring per [Table 4.4](#).

**Table 4.4 Conversion Rate**

CR<2:0>			CONVERSIONS / SECOND (CONVERSION TIME)
2	1	0	
0	0	0	Reserved
0	0	1	Reserved
0	1	0	Reserved
0	1	1	1 Conversion / sec
1	0	0	2 Conversions / sec
1	0	1	4 Conversions / sec (default)
1	1	0	8 Conversions / sec
1	1	1	16 Conversions / sec

## 4.5 Configuration 2 Register - (04h)

**Table 4.5 Configuration 2 Register**

ADDR	REGISTER	B7	B6	B5	B4	B3	B2	B1	B0	DEFAULT
04h	CFG2	-	-	-	-	MAX_RES	DA_n	COMP	REC	09h

The Configuration 2 Register controls the basic functionality of the EMC1053 that is NOT compatible with the EMC1023.

Bit 3 - MAX\_RES - controls the external diode conversion time during dynamic averaging. Although the dynamic averaging may be used to increase the ADC resolution, only 11 bits of data are available in the temperature registers.

- '0' - the dynamic averaging will set the ADC averaging factor at 1x when the conversion rate is set at 16 conversions per second and 2x at conversion rates lower than 16 per second.
- '1' (default) - the dynamic averaging will set the ADC averaging factor at 1x when the conversion rate is set at 16 conversions per second, 2x at 8 conversions / second and 4x at conversion rates lower than 8 per second.

Bit 2 - DA\_n - controls the dynamic digital averaging circuitry. See [Section 3.3.2](#).

- '0' (default) - dynamic averaging is enabled. Depending on the selected conversion rate, the ADC averaging factor is increased for the external diodes.
- '1' - dynamic averaging is disabled. The ADC averaging factor will remain fixed at 1x for all conversion rates and will allow increased power savings at the slower conversion rates.

Bit 1 - COMP - configures the device to perform a comparison for the Hotter of Two mode (see [Section 3.3, "Operation During Run Mode," on page 11.](#))

- '0' (default) - the device is in normal mode
- '1' - the device is in Hotter of Two mode. In this mode, the two external diode channels are measured and compared against each other. The hotter of the two channels has its data loaded

## Datasheet

into the External Diode 2 Data Registers. The Internal Diode and External Diode 1 Data Registers remain unaffected.

Bit 0 - REC - controls the Resistance Error Correction circuitry

- '0' - The Resistance Error Correction circuitry is disabled.
- '1' (default) - The Resistance Error Correction circuitry is active and will automatically correct for up to 100 ohms of series resistance in the diode lines for both External Diode 1 and External Diode 2 channels.

## 4.6 One Shot Register - (0Fh)

Table 4.6 One Shot Registers

ADDR	REGISTER	B7	B6	B5	B4	B3	B2	B1	B0	DEFAULT
0Fh	One Shot Conversion	Writing to this register address initiates the one-shot. The data is not important and is not stored								00h

The One Shot Register is an address place holder for the one-shot command. Writing to the address initiates the command. The data written is not important and is not stored. Reading from the one-shot registers will always return 00h.

## 4.7 Ideality Configuration Registers (27h - 28h)

Table 4.7 Ideality Configuration Registers

ADDR	REGISTER	B7	B6	B5	B4	B3	B2	B1	B0	DEFAULT
27h	Diode 1 Ideality Correction Factor	-	-	B5	B4	B3	B2	B1	B0	12h (1.008)
28h	Diode 2 Ideality Correction Factor	-	-	B5	B4	B3	B2	B1	B0	12h (1.008)

The Ideality Configuration Registers store the ideality correction factor that is applied to each external diode.

The table below shows the ideality factor settings for the Ideality Configuration registers. Shading indicates power-up default. All codes that are not listed are reserved and should not be used.

Beta Compensation and Resistance Error Correction automatically correct for most diode ideality errors, therefore it is not recommended that these settings be updated without consulting SMSC.

**Table 4.8 Ideality Factor Look Up Table**

SETTING	FACTOR	SETTING	FACTOR	SETTING	FACTOR
001000	0.9951	011000	1.0159	101000	1.0377
001001	0.9964	011001	1.0173	101001	1.0391
001010	0.9976	011010	1.0186	101010	1.0404
001011	0.9989	011011	1.0199	101011	1.0418
001100	1.0002	011100	1.0213	101100	1.0432
001101	1.0015	011101	1.0226	101101	1.0446
001110	1.0028	011110	1.0240	101110	1.0460
001111	1.0041	011111	1.0253	101111	1.0475
010000	1.0054	100000	1.0267	110000	1.0489
010001	1.0067	100001	1.0280	110001	1.0503
010010	1.0080	100010	1.0294		
010011	1.0093	100011	1.0308		
010100	1.0106	100100	1.0321		
010101	1.0119	100101	1.0335		
010110	1.0133	100110	1.0349		
010111	1.0146	100111	1.0363		

For CPU substrate transistors that require the BJT transistor model, the ideality factor behaves slightly differently than for discrete diode-connected transistors. Refer to [Table 4.9](#) when using a CPU substrate transistor.

**Table 4.9 Substrate Diode Ideality Factor Look-Up Table (BJT Model)**

SETTING	FACTOR	SETTING	FACTOR	SETTING	FACTOR
001000	0.9869	011000	1.0079	101000	1.0291
001001	0.9882	011001	1.0092	101001	1.0304
001010	0.9895	011010	1.0105	101010	1.0317
001011	0.9908	011011	1.0120	101011	1.0330
001100	0.9921	011100	1.0132	101100	1.0343
001101	0.9934	011101	1.0146	101101	1.0356
001110	0.9947	011110	1.0159	101110	1.0369
001111	0.9960	011111	1.0173	101111	1.0382
010000	0.9973	100000	1.0187	110000	1.0395

**Table 4.9 Substrate Diode Ideality Factor Look-Up Table (BJT Model) (continued)**

SETTING	FACTOR	SETTING	FACTOR	SETTING	FACTOR
010001	0.9986	100001	1.0200	110001	1.0408
010010	1.0000	100010	1.0213		
010011	1.0013	100011	1.0226		
010100	1.0026	100100	1.0239		
010101	1.0039	100101	1.0252		
010110	1.0053	100110	1.0265		
010111	1.0066	100111	1.0278		

**APPLICATION NOTE:** When measuring a 65nm Intel CPUs, the Ideality Setting should be the default 12h. When measuring 45nm Intel CPUs, the Ideality Setting should be 15h.

## 4.8 Beta Configuration Registers (29h - 2Ah)

**Table 4.10 Beta Configuration Registers**

ADDR	REGISTER	B7	B6	B5	B4	B3	B2	B1	B0	DEFAULT
29h	Diode 1 Beta Configuration	-	-	-	-	-	BETA<2:0>			07h
2Ah	Diode 2 Beta Configuration	-	-	-	-	-	BETA<2:0>			07h

By default, the beta compensation circuitry is disabled and the EMC1053 is configured to measure discrete diode-connected transistors. Writing to the Beta Configuration Registers will enable the beta compensation circuitry and should be used if measuring a CPU substrate diode.

The beta compensation circuit is able to compensate for beta variation within a given range. The beta configuration register is configured to the proper range to match the CPU to be monitored. The beta values should be set so that the minimum expected beta is not below the threshold indicated in [Table 4.11](#). Beta compensation is activated if the BETA<2:0> bits are set to any value other than 07h.

**Table 4.11 Beta Configuration Look Up Table**

BETA<2:0>			MINIMUM BETA
2	1	0	
0	0	0	0.11
0	0	1	0.18
0	1	0	0.25
0	1	1	0.33
1	0	0	0.43
1	0	1	1.00

**Table 4.11 Beta Configuration Look Up Table (continued)**

BETA<2:0>			MINIMUM BETA
2	1	0	
1	1	0	2.33
1	1	1	Disabled (default)

## 4.9 Product ID Register (EDh)

**Table 4.12 Product ID Register**

ADDR	REGISTER	B7	B6	B5	B4	B3	B2	B1	B0	DEFAULT
EDh	PID	0	0	1	1	1	1	X	X	3Ch (-1) 3Dh (-2) 3Eh (-3) 3Fh (-4)

The Product ID Register holds the unique product ID for identifying SMSC EMC products. See [Table 4.1](#) for a list of the product ID number for each version of the EMC1053.

## 4.10 Manufacturer ID Register (FEh)

**Table 4.13 Manufacturer ID Register**

ADDR	REGISTER	B7	B6	B5	B4	B3	B2	B1	B0	DEFAULT
FEh	SMSC	0	1	0	1	1	1	0	1	5Dh

The Manufacturer ID register contains an 8 bit word that identifies the manufacturer of the EMC1053 (SMSC = 5Dh).

## 4.11 Revision Register (FFh)

**Table 4.14 Revision Register**

ADDR	REGISTER	B7	B6	B5	B4	B3	B2	B1	B0	DEFAULT
FFh	REV	-	-	-	-	0	0	0	1	01h

The Revision register contains a 4 bit word that identifies the die revision.

# Chapter 5 Typical Operating Curves

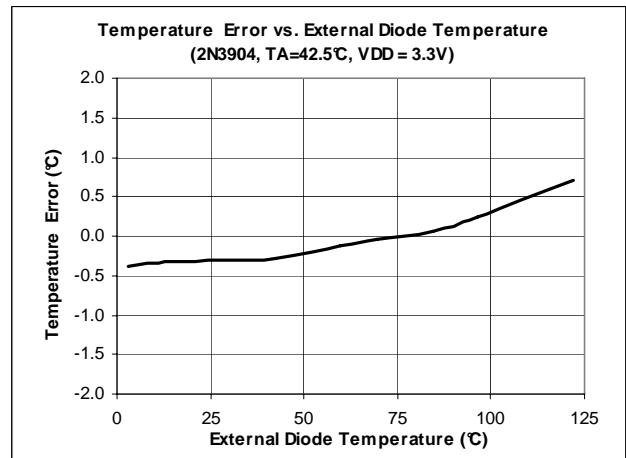
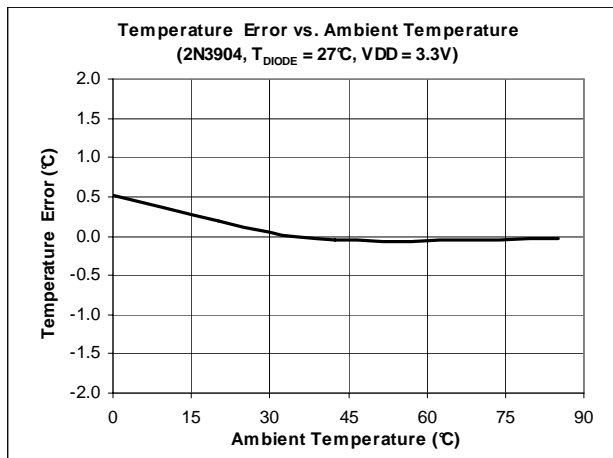
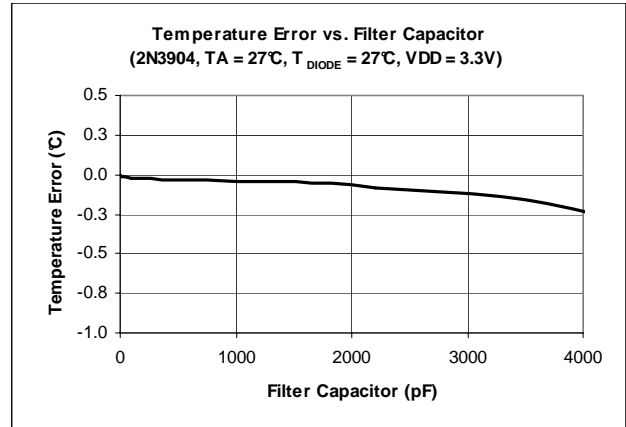
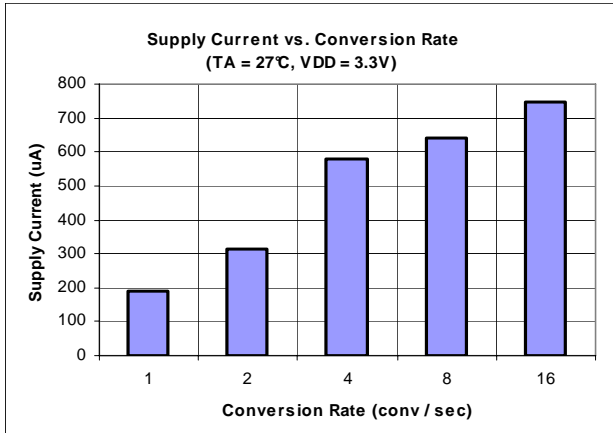

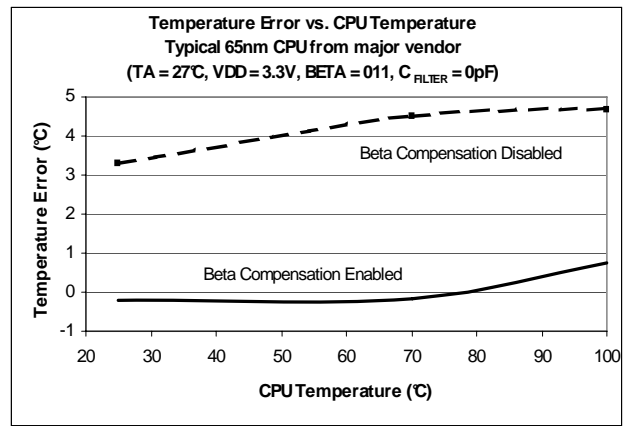
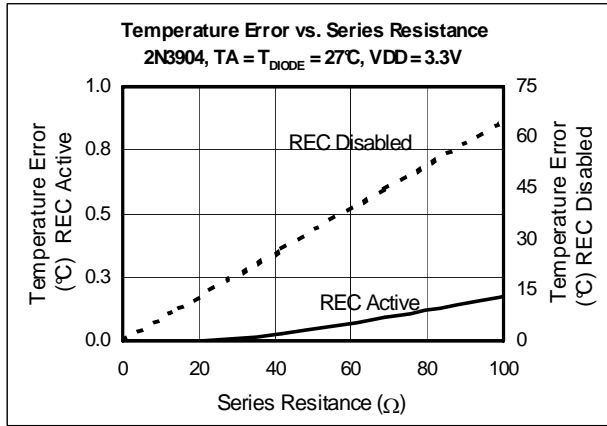
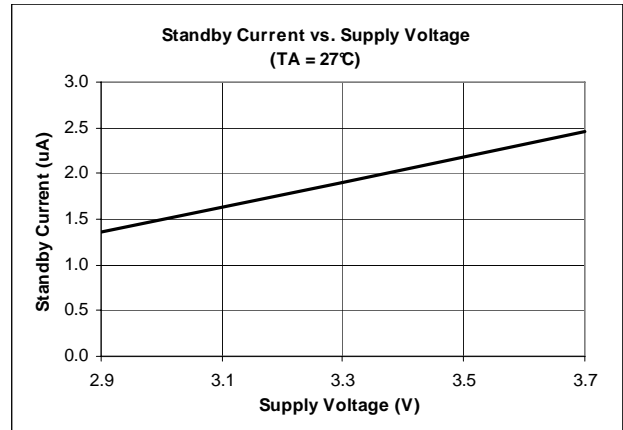
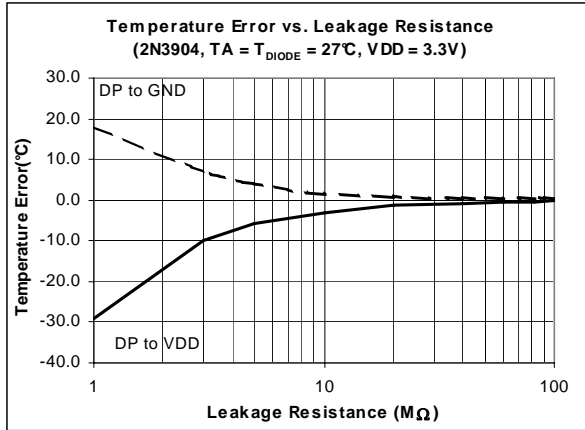

## Chapter 6 Package Outline

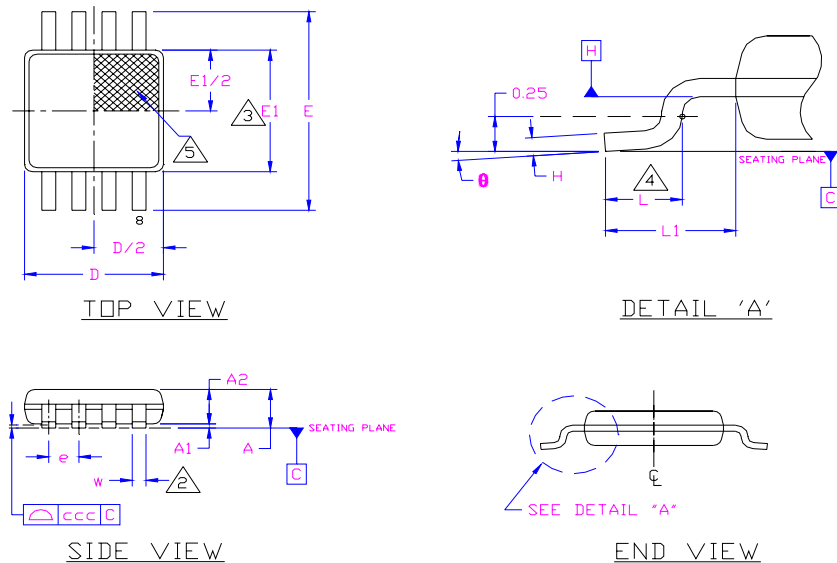

Figure 6.1 8-Pin MSOP Package Outline - 3x3mm Body 0.65mm Pitch

Table 6.1 8-Pin MSOP Package Parameters

	MIN	NOMINAL	MAX	REMARKS
A	0.80	~	1.10	Overall Package Height
A1	0.05	~	0.15	Standoff
A2	0.75	0.85	0.95	Body Thickness
D	2.80	3.00	3.20	X Body Size
E	4.65	4.90	5.15	Y Span
E1	2.80	~	3.20	Y body Size
H	0.08	~	0.23	Lead Foot Thickness
L	0.40	~	0.80	Lead Foot Length
L1	0.95 REF			Lead Length
e	0.65 BSC			Lead Pitch
$\theta$	0°	~	8°	Lead Foot Angle
W	0.22	~	0.38	Lead Width
ccc	~	~	0.10	Coplanarity

### Notes:

1. Controlling Unit: millimeters.
2. Tolerance on the true position of the leads is  $\pm 0.065$  mm maximum.
3. Package body dimensions D and E1 do not include mold protrusion or flash. Dimensions D and E1 to be determined at datum plane H. Maximum mold protrusion or flash is 0.15mm (0.006 inches) per end, and 0.15mm (0.006 inches) per side.
4. Dimension for foot length L measured at the gauge plane 0.25 mm above the seating plane.
5. Details of pin 1 identifier are optional but must be located within the zone indicated.



## 6.1 Package Markings

All devices will be marked on the first line of the top side with “1053”. On the second line, they will be marked with the appropriate -X number (-1, -2, etc), the Functional Revision “B” and Country Code (CC) .