

LAN88730



MII/RMII 10/100 Ethernet Transceiver for Automotive Applications

Features

- Designed, fabricated, tested, characterized and qualified for automotive applications
- TrueAuto™ design, service and support
- High-performance, low-power, single-chip Ethernet Physical Layer Transceiver (PHY)
- IEEE802.3/802.3u standards (Fast Ethernet) compliant
- ISO 802-3/IEEE 802.3 (10-BASE-T) compliant
- 10BASE-T/100BASE-TX and HP Auto-MDIX support
- Comprehensive flexPWR® technology
 - Flexible power management architecture
 - Up to 40% power savings from existing SMSC solutions
 - LVC MOS variable I/O voltage range: +1.6 V to +3.6 V
 - Integrated 1.2 V regulator with disable feature
- 32-pin (5 x 5 mm²) QFN lead-free, RoHS-compliant package with Media Independent Interface (MII) and Reduced Media Independent Interface (RMII™)
- Temperature range: -40 °C to +85 °C (LAN88730AM)
- Temperature range: -40 °C to +105 °C (LAN88730BM)

Applications

- Diagnostic interface for dealership service bay
- Fast software download interface with an On-board Diagnostic (OBD) connector
- Gateway service interface for dealership, aftermarket and repair shop
- In-vehicle engineering development interface
- Vehicle manufacturing test interface for production plant assembly line
- Legislated emissions check and/or safety inspections



Ordering Information

The LAN88730 is available as:

LAN88730AM Tray

Order No. B10364

LAN88730AM Tape & Reel

Order No. B10363

LAN88730BM Tray

Order No. B10366

LAN88730BM Tape & Reel

Order No. B10365

Description

The LAN88730 is a high-performance, low-power 10/100 Ethernet controller which incorporates the essential protocol requirements for operating an IEEE 802.3 10BASE-T and 802.3u 100BASE-TX compliant Ethernet node. It is specifically designed to meet the high reliability standards required by automotive applications, including on-board diagnostics and fast software download interfaces for central gateway and telematics modules, navigation systems, radio head units and connectivity devices. The LAN88730 offers increased access speed for diagnostics and software downloads when compared with the more traditional, slower speed interfaces that are typically used.

The LAN88730 provides a simple, digital interface via MII (IEEE 802.3u) to a standard MAC layer integrated in an embedded microcontroller. When built into an embedded device within the car, the chip can function as a network branch to the outside world, connecting the car to a personal computer, diagnostic tool or a complex Ethernet network in the repair shop.

The LAN88730 can be configured for either 10 or 100 Mbps Ethernet operation in full and half-duplex mode. To determine the best possible speed and duplex mode of operation, it automatically implements Auto-Negotiation.

HP Auto-MDIX is also supported and provides detection and correction of both direct connection and crossed Ethernet cabling.

TrueAuto

TrueAuto is SMSC's automotive quality process. It has proven its ability to deliver leading-edge quality and services for IC device products to fulfill the needs of the most demanding automotive customers. TrueAuto is a proven total automotive-grade quality approach. TrueAuto IC device robustness begins with SMSC's design for reliability techniques within the silicon IC itself: automotive-grade robustness and testability are designed into the IC. Once available in silicon, the IC is fully-characterized and qualified over a multitude of operating parameters to prove quality under the harshest conditions. In this, SMSC's TrueAuto approach significantly exceeds the usual automotive reliability standards and customer-specific requirements and goes far beyond the stress tests prescribed by the AEC-Q100 specifications. During the fabrication of TrueAuto products, extensive technologies and processes, such as enhanced monitors are used in order to continuously drive improvements in accordance with SMSC's zero Defects per Million (DPM) goals.

System Block Diagram

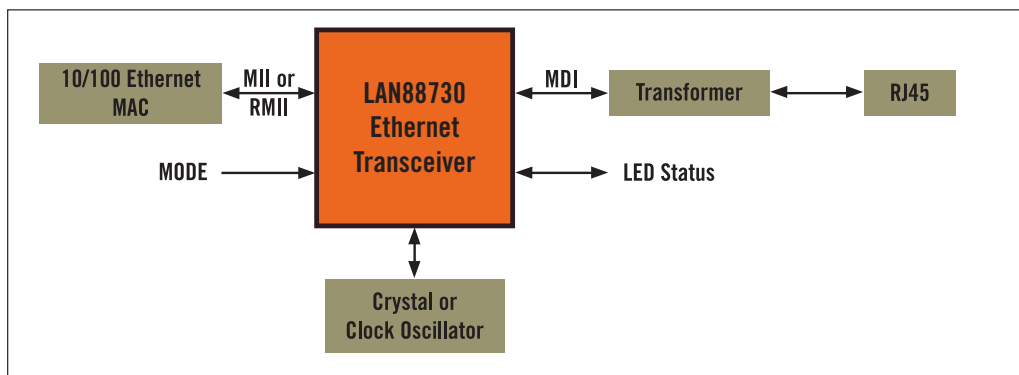

SMSC is committed to working toward a sustainable environment. We endeavor to make continual improvements in natural resource conservation through efficient product design and global operations thereby reducing greenhouse gas emissions generated by our products and facilities. Our environmental life cycle process seeks to reduce our carbon footprint through product life and recyclability and efficient use of materials, energy and transportation. We remain committed to promoting smart energy policies across our global organization.

Copyright © 2012 SMSC or its subsidiaries. All rights reserved. Although the information in this document has been checked and is believed to be accurate, no responsibility is assumed for inaccuracies. SMSC reserves the right to make changes to product descriptions and specifications at any time without notice. Contact your local SMSC sales office to obtain the latest product descriptions and specifications before placing your product order. The provision of this information does not convey any licenses under any patent rights or other intellectual property rights of SMSC or others. All sales are expressly conditional on your agreement to the terms and conditions of the most recently dated version of SMSC's standard Terms of Sale Agreement dated before the date of your order. Products may contain design defects or errors which may cause a product's functions to deviate from published product descriptions or specifications. Errata, listing these design defects or errors are available

upon request. SMSC products are not designed, intended, authorized or warranted for use in any life support or other application where product failure could cause or contribute to personal injury or severe property damage. Any and all such uses without prior written approval of an Officer of SMSC and further testing and/or modification will be fully at the risk of the customer. Copies of this document or other SMSC literature, as well as the Terms of Sale Agreement, may be obtained by visiting SMSC's website at <http://www.smisc.com>. SMSC, flexPWR, the SMSC logo and the TrueAuto logo are registered trademarks and TrueAuto is a trademark of Standard Microsystems Corporation ("SMSC"). Other names mentioned may be trademarks of their respective holders. All claims made herein speak as of the date of this material. The company does not undertake to update such statements. (03/12)

WEEE-Reg.-No. DE55114090