

DATA SHEET

PIMH9; PUMH9; PEMH9
NPN/NPN resistor-equipped
transistors; R1 = 10 k Ω , R2 = 47 k Ω

Product data sheet
Supersedes data of 2003 Sep 15

2004 Apr 14

NPN/NPN resistor-equipped transistors;
R1 = 10 kΩ, R2 = 47 kΩ

PIMH9; PUMH9;
PEMH9

FEATURES

- Built-in bias resistors
- Simplifies circuit design
- Reduces component count
- Reduces pick and place costs.

APPLICATIONS

- General purpose switching and amplification
- Inverter and interface circuits
- Circuit driver.

QUICK REFERENCE DATA

SYMBOL	PARAMETER	TYP.	MAX.	UNIT
V _{CEO}	collector-emitter voltage	–	50	V
I _O	output current (DC)	–	100	mA
TR1	NPN	–	–	–
TR2	NPN	–	–	–
R1	bias resistor	10	–	kΩ
R2	bias resistor	47	–	kΩ

DESCRIPTION

NPN/NPN resistor-equipped transistor (see “Simplified outline, symbol and pinning” for package details).

PRODUCT OVERVIEW

TYPE NUMBER	PACKAGE		MARKING CODE	PNP/PNP COMPLEMENT	NPN/PNP COMPLEMENT
	PHILIPS	EIAJ			
PEMH9	SOT666	–	H9	PEMB9	PEMD9
PIMH9	SOT457	SC-74	H9	–	–
PUMH9	SOT363	SC-88	H*9 ⁽¹⁾	PUMB9	PUMD9

Note

- * = p: Made in Hong Kong.
 * = t: Made in Malaysia.
 * = W: Made in China.

SIMPLIFIED OUTLINE, SYMBOL AND PINNING

TYPE NUMBER	SIMPLIFIED OUTLINE AND SYMBOL	PINNING	
		PIN	DESCRIPTION
PEMH9 PIMH9 PUMH9	<p>Top view MHC049</p>	1	emitter TR1
		2	base TR1
		3	collector TR2
		4	emitter TR2
		5	base TR2
		6	collectorTR1

NPN/NPN resistor-equipped transistors;
R1 = 10 k Ω , R2 = 47 k Ω

PIMH9; PUMH9; PEMH9

ORDERING INFORMATION

TYPE NUMBER	PACKAGE		
	NAME	DESCRIPTION	VERSION
PEMH9	–	plastic surface mounted package; 6 leads	SOT666
PIMH9	–	plastic surface mounted package; 6 leads	SOT457
PUMH9	–	plastic surface mounted package; 6 leads	SOT363

LIMITING VALUES

In accordance with the Absolute Maximum Rating System (IEC 60134).

SYMBOL	PARAMETER	CONDITIONS	MIN.	MAX.	UNIT	
Per transistor						
V _{CBO}	collector-base voltage	open emitter	–	50	V	
V _{CEO}	collector-emitter voltage	open base	–	50	V	
V _{EBO}	emitter-base voltage	open collector	–	10	V	
V _i	input voltage		–	+40	V	
			–	–10	V	
I _o	output current		–	100	mA	
I _{CM}	peak collector current		–	100	mA	
P _{tot}	total power dissipation	T _{amb} ≤ 25 °C				
		SOT363	note 1	–	200	mW
		SOT457	note 1	–	300	mW
	SOT666	notes 1 and 2	–	200	mW	
T _{stg}	storage temperature		–65	+150	°C	
T _j	junction temperature		–	150	°C	
T _{amb}	operating ambient temperature		–65	+150	°C	
Per device						
P _{tot}	total power dissipation	T _{amb} ≤ 25 °C				
		SOT363	note 1	–	300	mW
		SOT457	note 1	–	600	mW
	SOT666	notes 1 and 2	–	300	mW	

Notes

- Device mounted on an FR4 printed-circuit board, single-sided copper, standard footprint.
- Reflow soldering is the only recommended soldering method.

NPN/NPN resistor-equipped transistors;
R1 = 10 k Ω , R2 = 47 k Ω

PIMH9; PUMH9; PEMH9

THERMAL CHARACTERISTICS

SYMBOL	PARAMETER	CONDITIONS	VALUE	UNIT
Per transistor				
R _{th(j-a)}	thermal resistance from junction to ambient	T _{amb} ≤ 25 °C		
	SOT363	note 1	625	K/W
	SOT457	note 1	417	K/W
	SOT666	notes 1 and 2	625	K/W
Per device				
R _{th(j-a)}	thermal resistance from junction to ambient	T _{amb} ≤ 25 °C		
	SOT363	note 1	416	K/W
	SOT457	note 1	208	K/W
	SOT666	notes 1 and 2	416	K/W

Notes

1. Device mounted on an FR4 printed-circuit board, single-sided copper, standard footprint.
2. Reflow soldering is the only recommended soldering method.

CHARACTERISTICS

T_{amb} = 25 °C unless otherwise specified.

SYMBOL	PARAMETER	CONDITIONS	MIN.	TYP.	MAX.	UNIT
I _{CBO}	collector-base cut-off current	V _{CB} = 50 V; I _E = 0 A	–	–	100	nA
I _{CEO}	collector-emitter cut-off current	V _{CE} = 30 V; I _B = 0 A	–	–	1	μ A
		V _{CE} = 30 V; I _B = 0 A; T _j = 150 °C	–	–	50	μ A
I _{EBO}	emitter-base cut-off current	V _{EB} = 5 V; I _C = 0 A	–	–	150	μ A
h _{FE}	DC current gain	V _{CE} = 5 V; I _C = 5 mA	100	–	–	
V _{CEsat}	collector-emitter saturation voltage	I _C = 5 mA; I _B = 0.25 mA	–	–	100	mV
V _{i(off)}	input-off voltage	V _{CE} = 5 V; I _C = 100 μ A	–	0.7	0.5	V
V _{i(on)}	input-on voltage	V _{CE} = 0.3 V; I _C = 1 mA	1.4	0.8	–	V
R1	input resistor		7	10	13	k Ω
$\frac{R2}{R1}$	resistor ratio		3.7	4.7	5.7	
C _c	collector capacitance	V _{CB} = 10 V; I _E = i _e = 0 A; f = 1 MHz	–	–	2.5	pF

NPN/NPN resistor-equipped transistors;
 R1 = 10 kΩ, R2 = 47 kΩ

PIMH9; PUMH9; PEMH9

PACKAGE OUTLINES

Plastic surface-mounted package; 6 leads

SOT666

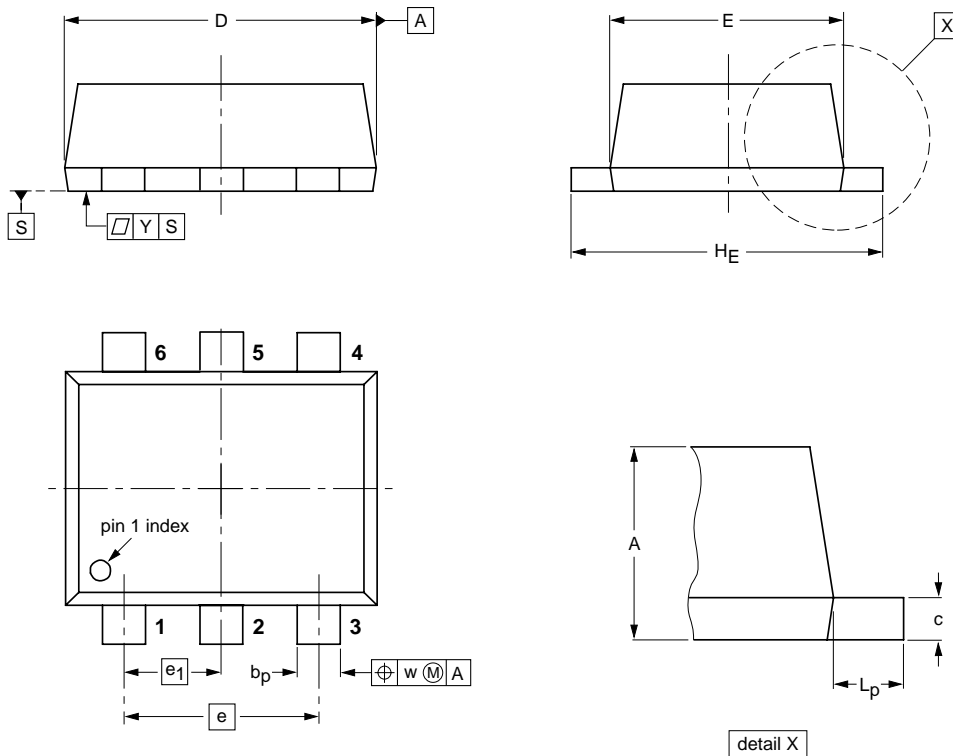

DIMENSIONS (mm are the original dimensions)

UNIT	A	b _p	c	D	E	e	e ₁	H _E	L _p	w	y
mm	0.6 0.5	0.27 0.17	0.18 0.08	1.7 1.5	1.3 1.1	1.0	0.5	1.7 1.5	0.3 0.1	0.1	0.1

OUTLINE VERSION	REFERENCES			EUROPEAN PROJECTION	ISSUE DATE
	IEC	JEDEC	JEITA		
SOT666					04-11-08 06-03-16

NPN/NPN resistor-equipped transistors;
 R1 = 10 kΩ, R2 = 47 kΩ

PIMH9; PUMH9; PEMH9

Plastic surface-mounted package (TSOP6); 6 leads

SOT457

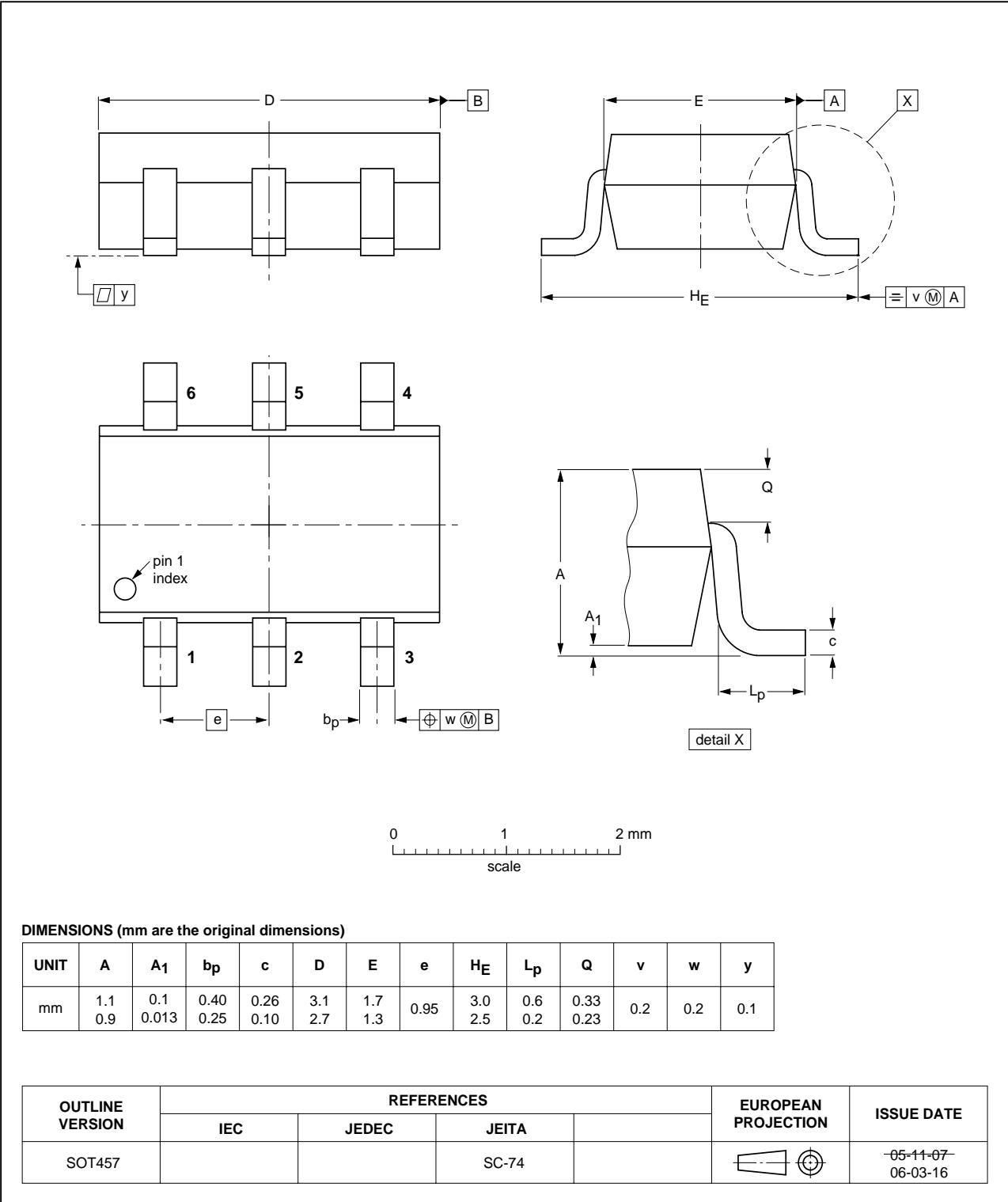

NPN/NPN resistor-equipped transistors;
R1 = 10 kΩ, R2 = 47 kΩ

PIMH9; PUMH9; PEMH9

Plastic surface-mounted package; 6 leads

SOT363

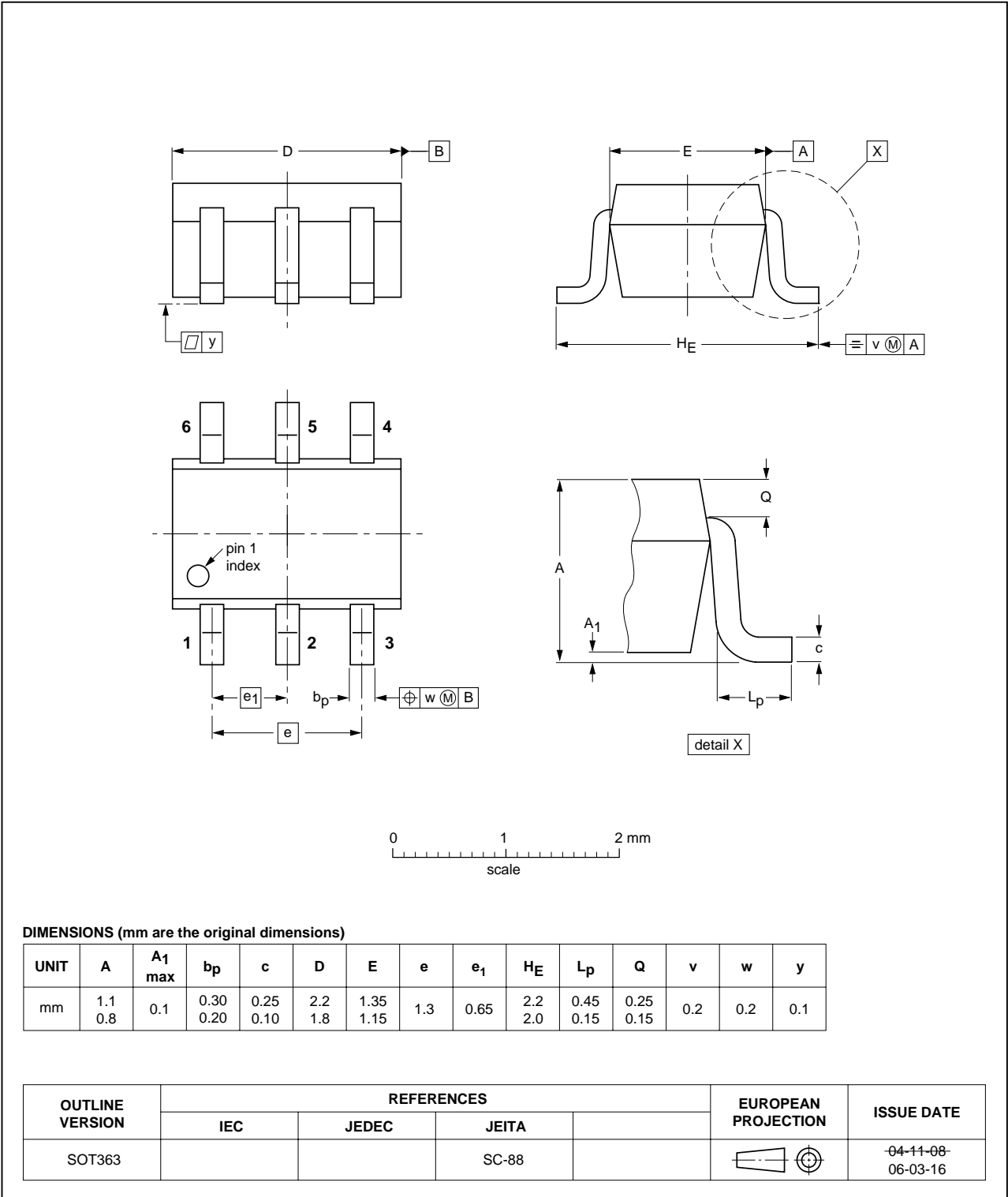

NPN/NPN resistor-equipped transistors;
R1 = 10 k Ω , R2 = 47 k Ω

PIMH9; PUMH9; PEMH9

DATA SHEET STATUS

DOCUMENT STATUS ⁽¹⁾	PRODUCT STATUS ⁽²⁾	DEFINITION
Objective data sheet	Development	This document contains data from the objective specification for product development.
Preliminary data sheet	Qualification	This document contains data from the preliminary specification.
Product data sheet	Production	This document contains the product specification.

Notes

1. Please consult the most recently issued document before initiating or completing a design.
2. The product status of device(s) described in this document may have changed since this document was published and may differ in case of multiple devices. The latest product status information is available on the Internet at URL <http://www.nxp.com>.

DISCLAIMERS

General — Information in this document is believed to be accurate and reliable. However, NXP Semiconductors does not give any representations or warranties, expressed or implied, as to the accuracy or completeness of such information and shall have no liability for the consequences of use of such information.

Right to make changes — NXP Semiconductors reserves the right to make changes to information published in this document, including without limitation specifications and product descriptions, at any time and without notice. This document supersedes and replaces all information supplied prior to the publication hereof.

Suitability for use — NXP Semiconductors products are not designed, authorized or warranted to be suitable for use in medical, military, aircraft, space or life support equipment, nor in applications where failure or malfunction of an NXP Semiconductors product can reasonably be expected to result in personal injury, death or severe property or environmental damage. NXP Semiconductors accepts no liability for inclusion and/or use of NXP Semiconductors products in such equipment or applications and therefore such inclusion and/or use is at the customer's own risk.

Applications — Applications that are described herein for any of these products are for illustrative purposes only. NXP Semiconductors makes no representation or warranty that such applications will be suitable for the specified use without further testing or modification.

Limiting values — Stress above one or more limiting values (as defined in the Absolute Maximum Ratings System of IEC 60134) may cause permanent damage to the device. Limiting values are stress ratings only and operation of the device at these or any other conditions

above those given in the Characteristics sections of this document is not implied. Exposure to limiting values for extended periods may affect device reliability.

Terms and conditions of sale — NXP Semiconductors products are sold subject to the general terms and conditions of commercial sale, as published at <http://www.nxp.com/profile/terms>, including those pertaining to warranty, intellectual property rights infringement and limitation of liability, unless explicitly otherwise agreed to in writing by NXP Semiconductors. In case of any inconsistency or conflict between information in this document and such terms and conditions, the latter will prevail.

No offer to sell or license — Nothing in this document may be interpreted or construed as an offer to sell products that is open for acceptance or the grant, conveyance or implication of any license under any copyrights, patents or other industrial or intellectual property rights.

Export control — This document as well as the item(s) described herein may be subject to export control regulations. Export might require a prior authorization from national authorities.

Quick reference data — The Quick reference data is an extract of the product data given in the Limiting values and Characteristics sections of this document, and as such is not complete, exhaustive or legally binding.

NXP Semiconductors

Customer notification

This data sheet was changed to reflect the new company name NXP Semiconductors, including new legal definitions and disclaimers. No changes were made to the technical content, except for package outline drawings which were updated to the latest version.

Contact information

For additional information please visit: <http://www.nxp.com>

For sales offices addresses send e-mail to: salesaddresses@nxp.com

© NXP B.V. 2009

All rights are reserved. Reproduction in whole or in part is prohibited without the prior written consent of the copyright owner.

The information presented in this document does not form part of any quotation or contract, is believed to be accurate and reliable and may be changed without notice. No liability will be accepted by the publisher for any consequence of its use. Publication thereof does not convey nor imply any license under patent- or other industrial or intellectual property rights.

Printed in The Netherlands

R75/04/pp9

Date of release: 2004 Apr 14

Document order number: 9397 750 13091

