

1. General description

The HITAG product line is well known and established in the contactless identification market.

Due to the open marketing strategy of NXP Semiconductors there are various manufacturers well established for both the transponders/cards as well as the read/write devices. All of them supporting HITAG 1, HITAG 2 and HITAG S transponder ICs.

With the new HITAG μ family, this existing infrastructure is extended with the next generation of ICs being substantially smaller in mechanical size, lower in cost, offering more operation distance and speed, but still being operated with the same reader infrastructure and transponder manufacturing equipment.

The protocol and command structure for HITAG μ ISO 18000 is design to support Reader Talks First (RTF) operation, including anti-collision algorithm.

2. Features and benefits

2.1 Features

- Integrated circuit for contactless identification transponders and cards
- Integrated resonance capacitor of 210 pF with $\pm 3\%$ tolerance or 280 pF with $\pm 5\%$ tolerance over full production
- Frequency range 100 kHz to 150 kHz

2.2 Protocol

- Modulation read/write device \rightarrow transponder: 100 % ASK and binary pulse length coding
- Modulation transponder \rightarrow read/write device: Strong ASK modulation with anti-collision, Manchester coding
- Fast anti-collision protocol
- Data integrity check (CRC)
- Reader Talks First (RTF) Mode
- Data rate read/write device to transponder: 5.2 kbit/s
- Data rates transponder to read/write device: 4 kbit/s

2.3 Memory

- 1760 bit
- Up to 10 000 erase/write cycles
- 10 years non-volatile data retention
- Memory Lock functionality
- 32-bit password feature

2.4 Supported standards

- Full compliant to ISO 18000-2

2.5 Security features

- 48-bit Unique Item Identification (UID)

2.6 Delivery types

- Sawn, gold-bumped 8" wafer
- HVSON2
- SOT-1122

3. Applications

- Industrial applications
- Casino gambling

4. Ordering information

Table 1. Ordering information

Type number	Package		Type	Version
	Name	Description		
HTMS1301FUG/AM	Wafer	sawn, megabumped wafer, 150 μ m, 8 inch, UV	HITAG μ ISO 18000, 210pF	-
HTMS8301FUG/AM	Wafer	sawn, megabumped wafer, 150 μ m, 8 inch, UV	HITAG μ ISO 18000, 280pF	-
HTMS1301FTB/AF	XSON3	plastic extremely thin small outline package; no leads; 4 terminals; body 1 x 1.45 x 0.5 mm	HITAG μ ISO 18000, 210pF	SOT1122
HTMS8301FTB/AF	XSON3	plastic extremely thin small outline package; no leads; 4 terminals; body 1 x 1.45 x 0.5 mm	HITAG μ ISO 18000, 280pF	SOT1122
HTMS1301FTK/AF	HVSON2	plastic thermal enhanced very thin small outline package; no leads; 2 terminals; body 3 x 2 x 0.85 mm	HITAG μ ISO 18000, 210pF	SOT899-1
HTMS8301FTK/AF	HVSON2	plastic thermal enhanced very thin small outline package; no leads; 2 terminals; body 3 x 2 x 0.85 mm	HITAG μ ISO 18000, 280pF	SOT899-1

5. Block diagram

The HITAG μ ISO 18000 transponder IC require no external power supply. The contactless interface generates the power supply and the system clock via the resonant circuitry by inductive coupling to the read/write device (RWD). The interface also demodulates data transmitted from the RWD to the HITAG μ ISO 18000 transponder IC, and modulates the magnetic field for data transmission from the HITAG μ ISO 18000 transponder IC to the RWD.

Data are stored in a non-volatile memory (EEPROM). The EEPROM has a capacity of 1760 bit and is organized in blocks.

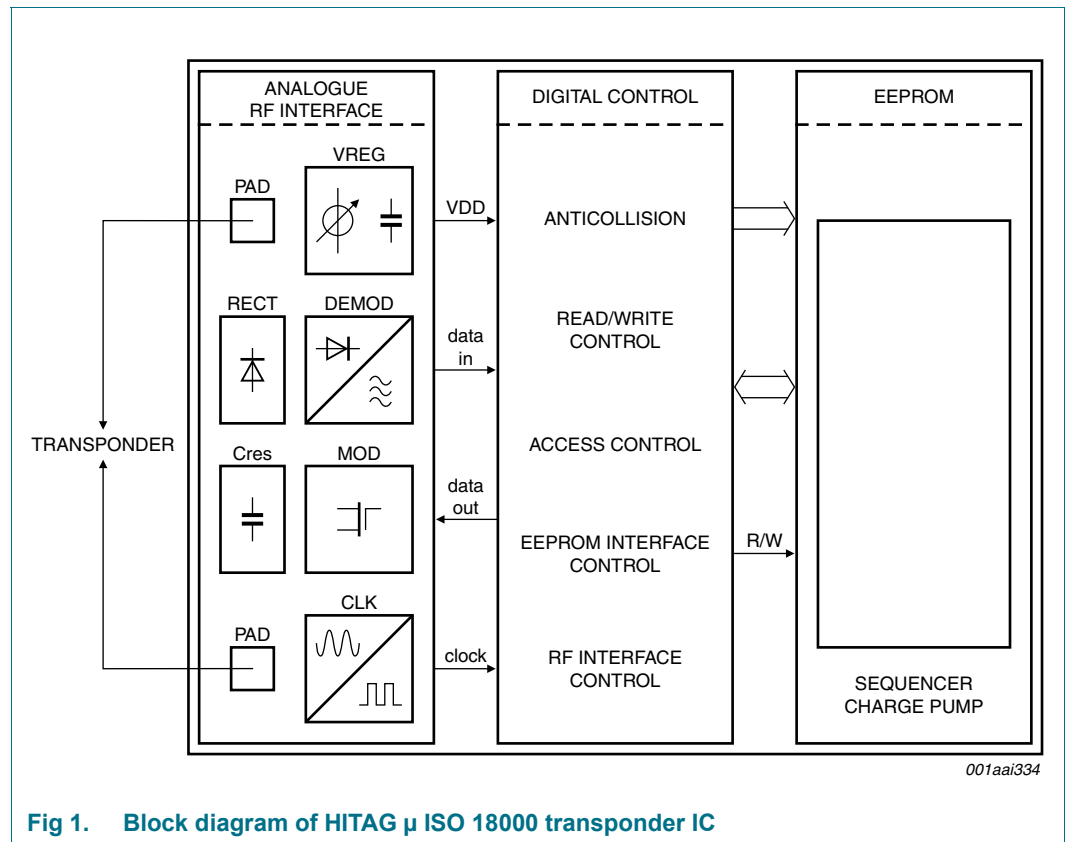

6. Pinning information

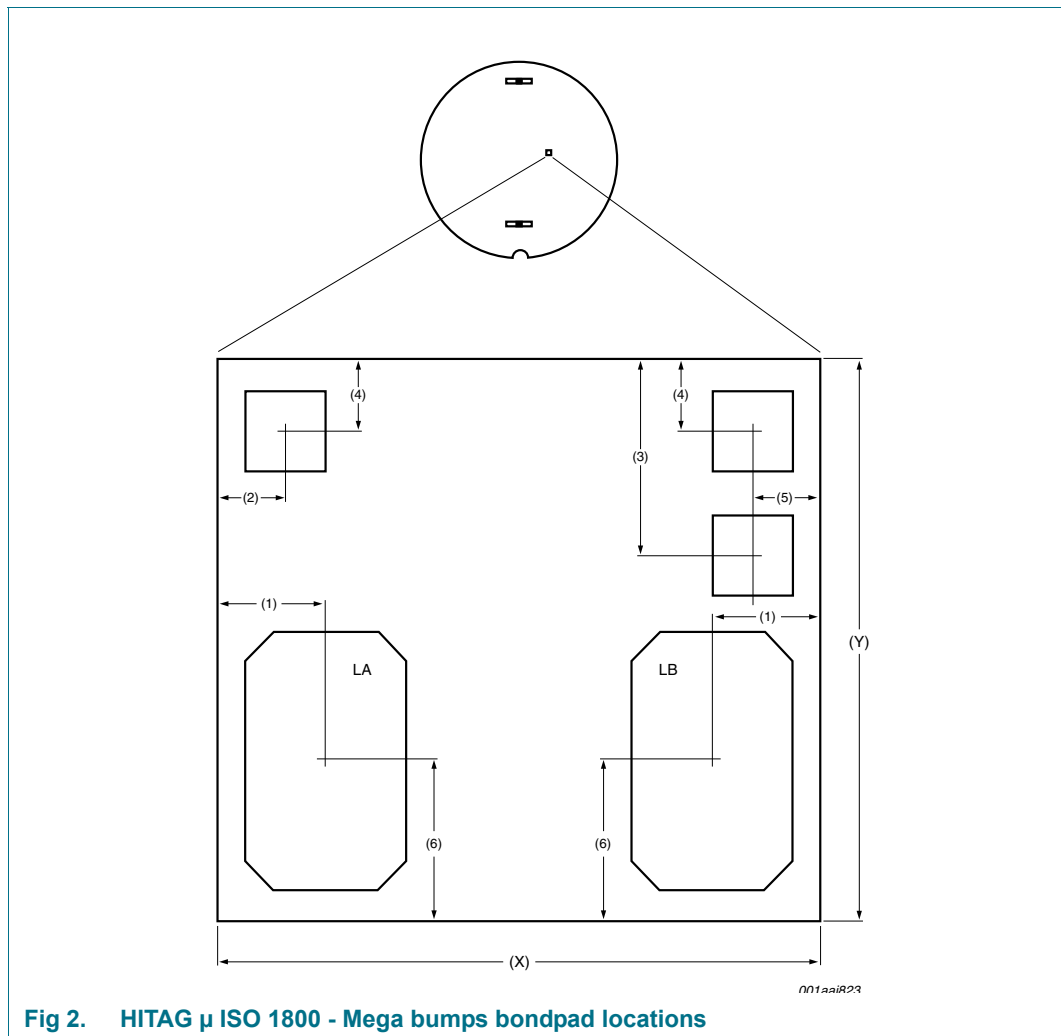

Fig 2. HITAG μ ISO 1800 - Mega bumps bondpad locations

Table 2. HITAG μ ISO 18000 - Mega bumps dimensions

Description	Dimension
(X) chip size	550 μm
(Y) chip size	550 μm
(1) pad center to chip edge	100.5 μm
(2) pad center to chip edge	48.708 μm
(3) pad center to chip edge	180.5 μm
(4) pad center to chip edge	55.5 μm
(5) pad center to chip edge	48.508 μm
(6) pad center to chip edge	165.5 μm
Bump Size:	
LA, LB	294 x 164 μm
Remaining pads	60 x 60 μm

Note: All pads except LA and LB are electrically disconnected after dicing.

7. Mechanical specification

7.1 Wafer specification

See [Ref. 2 "General specification for 8" wafer on UV-tape with electronic fail die marking"](#).

7.1.1 Wafer

- Designation: each wafer is scribed with batch number and wafer number
- Diameter: 200 mm (8")
- Thickness: $150 \mu\text{m} \pm 15 \mu\text{m}$
- Process: CMOS $0.14 \mu\text{m}$
- Batch size: 25 wafers
- PGDW: 91981

7.1.2 Wafer backside

- Material: Si
- Treatment: ground and stress release
- Roughness: R_a max. $0.5 \mu\text{m}$, R_t max. $5 \mu\text{m}$

7.1.3 Chip dimensions

- Die size without scribe: $550 \mu\text{m} \times 550 \mu\text{m} = 302500 \mu\text{m}^2$
- Scribe line width:
 - X-dimension: $15 \mu\text{m}$ (scribe line width is measured between nitride edges)
 - Y-dimension: $15 \mu\text{m}$ (scribe line width is measured between nitride edges)
- Number of pads: 5

7.1.4 Passivation on front

- Type: sandwich structure
- Material: PE-Nitride (on top)
- Thickness: $1.75 \mu\text{m}$ total thickness of passivation

7.1.5 Au bump

- Bump material: > 99.9% pure Au
- Bump hardness: 35 – 80 HV 0.005
- Bump shear strength: > 70 MPa
- Bump height: 18 μm
- Bump height uniformity:
 - within a die: $\pm 2 \mu\text{m}$
 - within a wafer: $\pm 3 \mu\text{m}$
 - wafer to wafer: $\pm 4 \mu\text{m}$
- Bump flatness: $\pm 1.5 \mu\text{m}$
- Bump size:
 - LA, LB 294 x 164 μm
 - TEST, GND, VDD 60 x 60 μm
 - Bump size variation: $\pm 5 \mu\text{m}$
- Under bump metallization: sputtered TiW

7.1.6 Fail die identification

No inkdots are applied to the wafer.

Electronic wafer mapping (SECS II format) covers the electrical test results and additionally the results of mechanical/visual inspection.

See [Ref. 2 “General specification for 8” wafer on UV-tape with electronic fail die marking”](#).

7.1.7 Map file distribution

See [Ref. 2 “General specification for 8” wafer on UV-tape with electronic fail die marking”](#).

8. Functional description

8.1 Memory organization

The EEPROM has a capacity of 1760 bit and is organized in blocks of 4 bytes each (1 block = 32 bits). A block is the smallest access unit.

The HITAG μ ISO 18000 transponder IC memory organization is shown in [Table 3](#) “Memory organization”.

For permanent lock of blocks please refer to [Section 14.8 “LOCK BLOCK”](#).

8.1.1 Memory organization

Table 3. Memory organization

Block address	Content	Password Access
FFh	User Config	
FEh	PWD	
36h	User Memory	bit6=0 bit5=0 R/W ^[2] bit6=0 bit5=1 RO ^[1] bit6=1 bit5=0 R/W(P) ^[3] bit6=1 bit5=1 R/W(P) ^[3]
35h		
...		
14h		
13h		
12h		
11h		
10h	User Memory	bit4=0 R/W ^[2] bit4=1 RO ^[1]
0Fh		
0Eh		
0Dh		
0Ch		
0Bh		
0Ah		
09h		
08h		
07h		
06h		
05h		
04h		
03h		
02h		
01h		
00h		

[1] RO: Read without password, write with password

[2] R/W: Read and write without password

[3] R/W(P): Read and write with password

8.2 Memory configuration

The User Configuration Block consists of one configurable byte (Byte0) and three reserved bytes (Byte1 to Byte3)

The bits in the User Configuration Block enable a customized memory configuration of the HITAG μ ISO 18000 transponder ICs.

Three areas (1 to 127bit, 1 to 511 bits and upper memory) can be restricted to read/write access.

The User Configuration Block (User Config) is programmable by using WRITE SINGLE BLOCK command at address FFh. Bits 7 to 31 (Byte1 to Byte3) are reserved for further usage.

The user configuration block (block address FFh) and the password block (block address FEh) can be locked with the LOCK BLOCK command.

Attention: The lock of the blocks is permanently and therefore irreversible!

Table 4. User configuration block to Byte0

Byte0							Description
bit6	bit5	bit4	bit3	bit2	bit1	bit 0	Bit-no.
PWD (r/w) [2] Bit512... Max	PWD (w) [1] Bit512... Max	PWD (w) [1] Bit128... 511	PWD (w) [1] Bit0... 127	RFU	RFU	RFU	
							Value/meaning

[1] PWD(w)=1: read without password and write with password

[2] PWD(r/w)=1: read and write with password

9. General requirements

The HITAG μ ISO 18000 transponder IC is compatible with the ISO 18000-2 standard.

At the time a HITAG μ ISO 18000 based transponder is in the interrogator field it doesn't respond until it receives a request from the RWD.

All communication from reader to HITAG μ ISO 18000 transponder ICs and vice versa and the CRC error detection bits (if applicable) are transmitted starting with LSB first.

In the case that multiple HITAG μ ISO 18000 based transponders are in the interrogation field which cause collisions the RWD has to start the anticollision procedure as described in this document.

10. HITAG μ ISO 18000 transponder IC air interface

10.1 Downlink communication signal interface - RWD to HITAG μ ISO 18000 transponder IC

10.1.1 Modulation parameters

Communications between RWD and HITAG μ ISO 18000 transponder IC takes place using ASK modulation with a modulation index of $m > 90\%$.

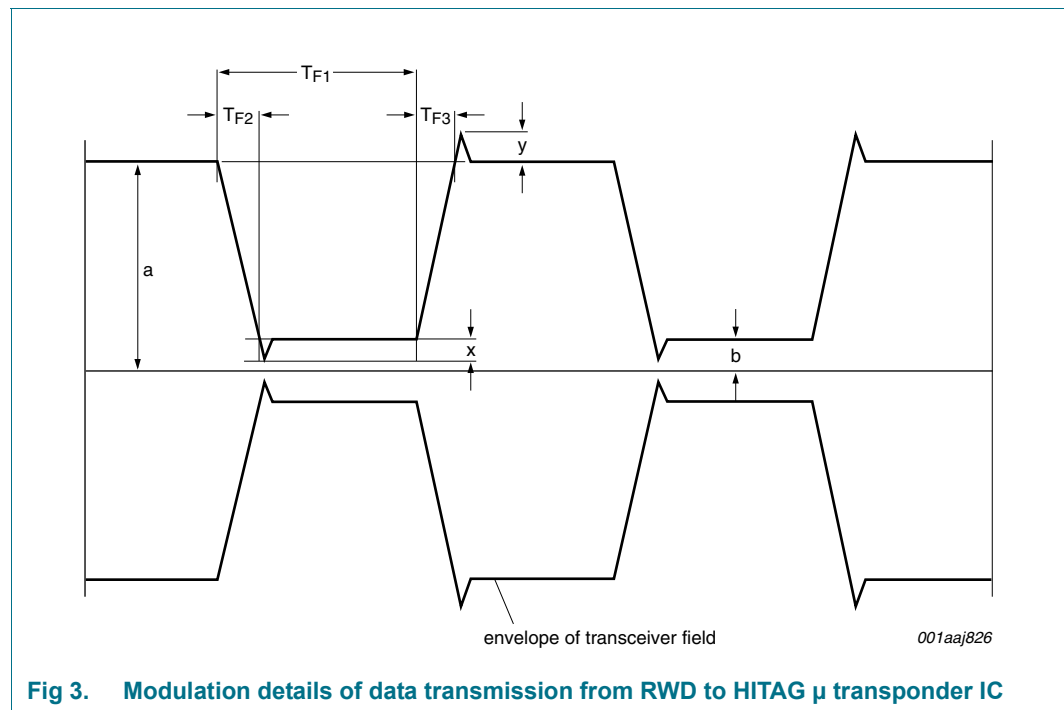

Fig 3. Modulation details of data transmission from RWD to HITAG μ transponder IC

Table 5. Modulation coding times^{[1][2]}

Symbol	Min	Max
$m = (a-b)/(a+b)$	90%	100%
T_{F1}	$4 \times T_c$	$10 \times T_c$
T_{F2}	0	$0.5 \times T_{F1}$
T_{F3}	0	$0.5 \times T_{Fd0}$
x	0	$0.05 \times a$
y	0	$0.05 \times a$

[1] $T_{Fd0} > T_{F1} + T_{F3} + 3 \times T_c$

[2] T_c ...Carrier period time ($1/125\text{kHz} = 8 \mu\text{s}$ nominal)

10.1.2 Data rate and data coding

The RWD to HITAG μ ISO 18000 transponder IC communication uses Pulse Interval Encoding. The RWD creates pulses by switching the carrier off as described in [Figure 4](#). The time between the falling edges of the pulses determines either the value of the data bit '0', the data bit '1', a code violation or a stop condition.

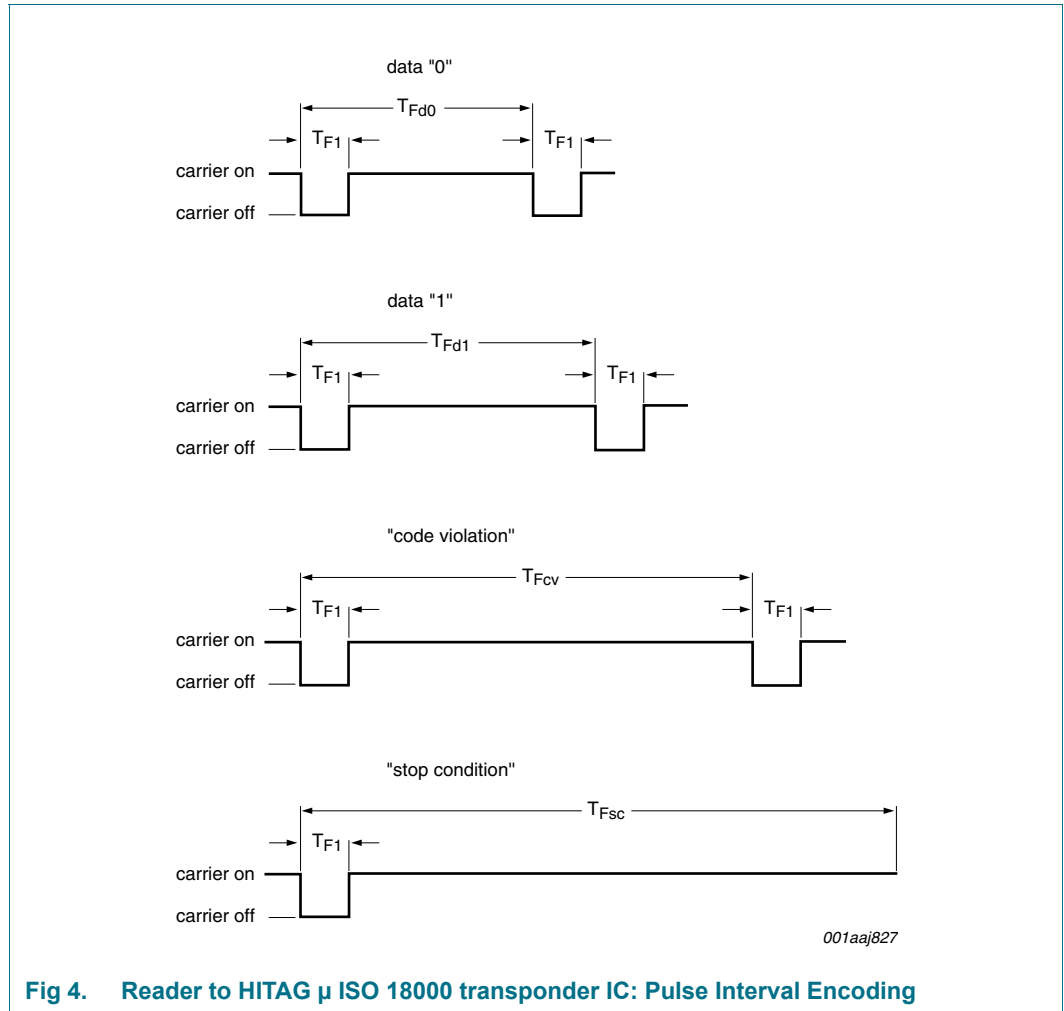

Fig 4. Reader to HITAG μ ISO 18000 transponder IC: Pulse Interval Encoding

Assuming equal distributed data bits '0' and '1', the data rate is in the range of about 5.2 kbit/s.

Table 6. Data coding times [1]

Meaning	Symbol	Min	Max
Carrier off time	T_{F1}	$4 \times T_c$	$10 \times T_c$
Data "0" time	T_{Fd0}	$18 \times T_c$	$22 \times T_c$
Data "1" time	T_{Fd1}	$26 \times T_c$	$30 \times T_c$
Code violation time	T_{Fcv}	$34 \times T_c$	$38 \times T_c$
Stop condition time	T_{Fsc}	$\geq 42 \times T_c$	n/a

[1] T_c ...Carrier period time ($1/125kHz = 8 \mu s$ nominal)

10.1.3 RWD - Start of frame pattern

A RWD request always starts with a SOF pattern for ease of synchronization. The SOF pattern consists of an encoded data bit '0' and a 'code violation'.

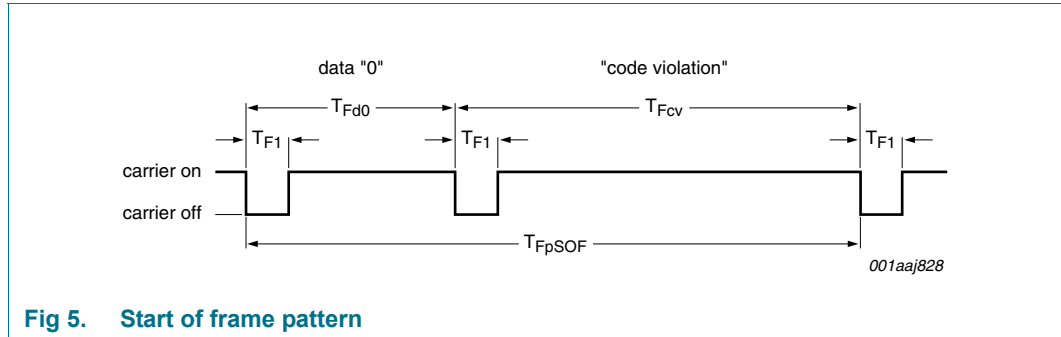

Fig 5. Start of frame pattern

The HITAG μ ISO 18000 transponder IC shall be ready to receive a SOF from the RWD within 1.2 ms after having sent a response to the RWD.

The HITAG μ ISO 18000 transponder IC shall be ready to receive a SOF from the RWD within 2.5 ms after the RWD has established the powering field.

10.1.4 RWD - End of frame pattern

For slot switching during a multi-slot anticollision sequence, the RWD request is an EOF pattern. The EOF pattern is represented by a RWD 'Stop condition'.

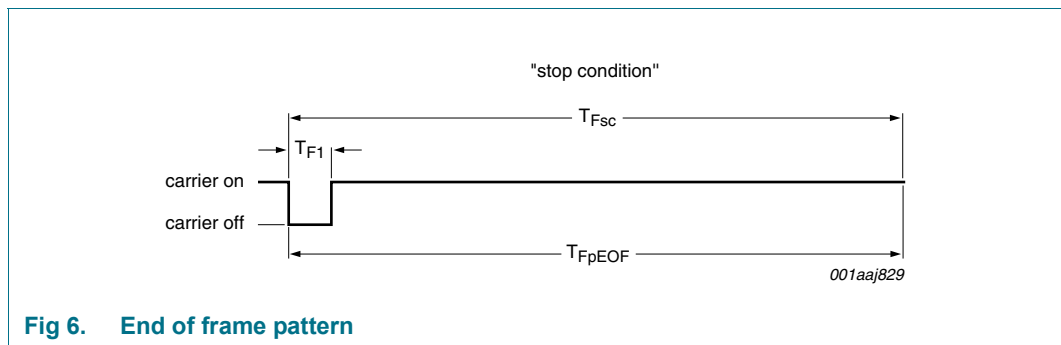

Fig 6. End of frame pattern

10.2 Communication signal interface - HITAG μ ISO 18000 transponder IC to RWD

10.2.1 Data rate and data coding

The HITAG μ ISO 18000 transponder IC accepts the following data rate and encoding scheme:

- $1/T_{Fd}$ Manchester coded data signal on the response to the HITAG μ ISO 18000 transponder IC
- $1/(2 \times T_{Fd})$ dual pattern data coding when responding within the inventory process

$$T_{Fd} = 32 / f_c = 32 \times T_c$$

Remark: The slower data rate used during the inventory process allows for improving the collision detection when several HITAG μ ISO 18000 transponder ICs are present in the RWD field, especially if some transponder ICs are in the near field and others in the far field.

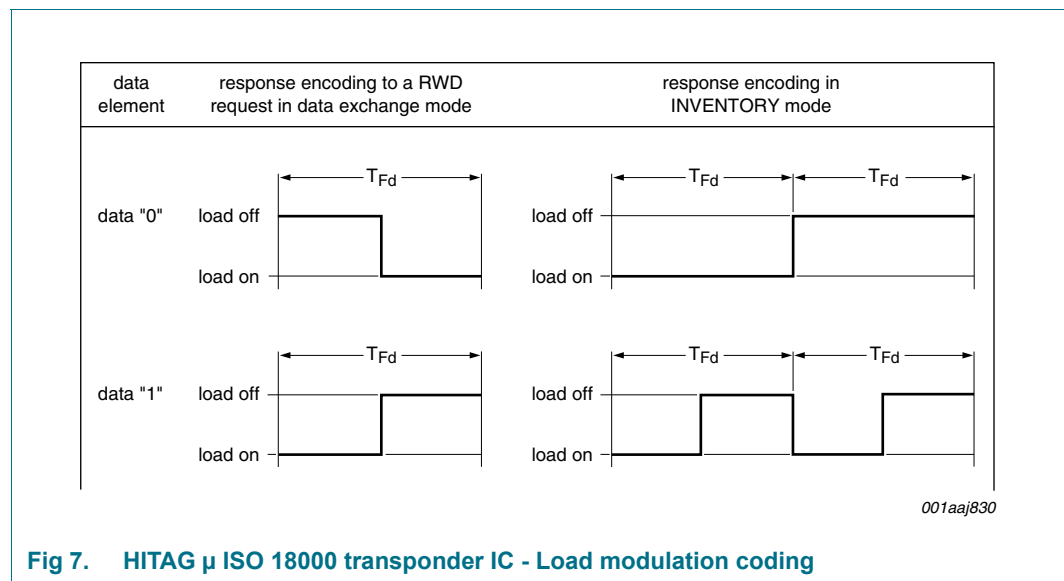

10.2.2 Start of frame pattern

The HITAG μ ISO 18000 transponder IC response always starts with a SOF pattern. The SOF is a Manchester encoded bit sequence of '110'.

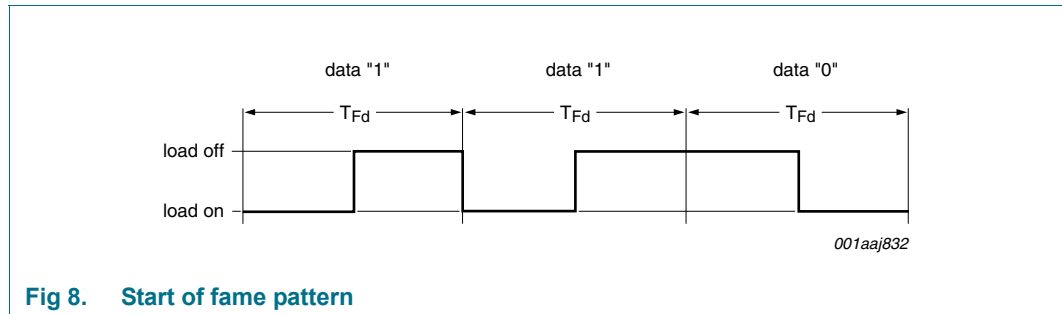

10.2.3 End of frame pattern

A specific EOF pattern is neither used nor specified for the HITAG μ ISO 18000 transponder IC response. An EOF is detected by the RWD if there is no load modulation for more than two data bit periods (T_{Fd}).

11. General protocol timing specification

For requests where an EEPROM erase and/or programming operation is required, the transponder IC returns its response when it has completed the write/lock operation. This will be latest after 20 ms upon detection of the last falling edge of the RWD request or after the RWD has switched off the field.

11.1 Waiting time before transmitting a response after an EOF from the RWD

When the HITAG μ ISO 18000 transponder IC has detected an EOF of a valid RWD request or when this EOF is in the normal sequence of a valid RWD request, it shall wait for T_{Fp1} before starting to transmit its response to a RWD request or when switching to the next slot in an inventory process.

T_{Fp1} starts from the detection of the falling edge of the EOF received from the RWD.

Remark: The synchronization on the falling edge from the RWD to the EOF of the HITAG μ ISO 18000 transponder IC is necessary to ensure the required synchronization of the response.

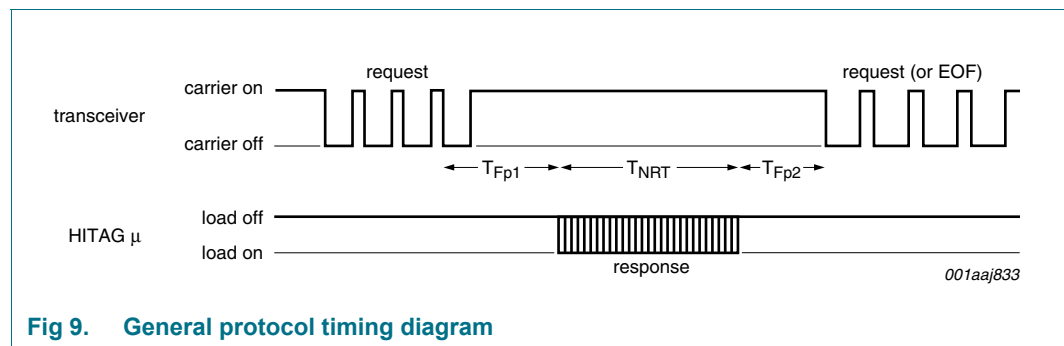

Fig 9. General protocol timing diagram

The minimum value of T_{Fp1} is $T_{Fp1min} = 204 \times T_C$

The typical value of T_{Fp1} is $T_{Fp1typ} = 209 \times T_C$

The maximum value of T_{Fp1} is $T_{Fp1max} = 213 \times T_C$

If the HITAG μ ISO 18000 transponder IC detects a carrier modulation during this time (T_{Fp1}), it shall reset its T_{Fp1} -timer and wait for a further time (T_{Fp1}) before starting to transmit its response to a RWD request or to switch to the next slot when in an inventory process.

11.2 RWD waiting time before sending a subsequent request

- When the RWD has received a HITAG μ ISO 18000 response to a previous request other than inventory or quiet, it needs to wait T_{Fp2} before sending a subsequent request. T_{Fp2} starts from the time the last bit has been received from the HITAG μ ISO 18000.
- When the RWD has sent a quiet request, it needs to wait T_{Fp2} before sending a subsequent request. T_{Fp2} starts from the end of the quiet request's EOF (falling edge of EOF pulse + $42 \times T_C$). This results in a waiting time of $(150 \times T_C + 42 \times T_C)$ before the next request.

The minimum value of T_{Fp2} is $T_{Fp2min} = 150 \times T_C$ ensures that the HITAG μ ISO 18000 ICs are ready to receive a subsequent request.

Remark: The RWD needs to wait at least 2.5 ms after it has activated the electromagnetic field before sending the first request, to ensure that the HITAG μ ISO 18000 transponder ICs are ready to receive a request.

- When the RWD has sent an inventory request, it is in an inventory process.

11.3 RWD waiting time before switching to next inventory slot

An inventory process is started when the RWD sends an inventory request. For a detailed explanation of the inventory process refer to [Section 14.3](#) and [Section 14.4](#).

To switch to the next slot, the RWD sends an EOF after waiting a time period specified in the following sub-clauses.

11.3.1 RWD started to receive one or more HITAG μ ISO 18000 transponder IC responses

During an inventory process, when the RWD has started to receive one or more HITAG μ ISO 18000 transponder IC responses (i.e. it has detected a transponder IC SOF and/or a collision), it shall

- wait for the complete reception of the HITAG μ ISO 18000 transponder IC responses (i.e. when a last bit has been received or when the nominal response time T_{NRT} has elapsed),
- wait an additional time T_{Fp2} and then send an EOF to switch to the next slot, if a 16 slot anticollision request is processed, or send a subsequent request (which could be again an inventory request).

T_{Fp2} starts from the time the last bit has been received from the HITAG μ ISO 18000 transponder IC.

The minimum value of T_{Fp2} is $T_{Fp2min} = 150 \times T_C$.

T_{NRT} is dependant on the anticollisions current mask value and on the setting of the CRCT flag.

11.3.2 RWD receives no HITAG μ ISO 18000 transponder IC response

During an inventory process, when the RWD has received no HITAG μ ISO 18000 transponder IC response, it needs to wait T_{Fp3} before sending a subsequent EOF to switch to the next slot, if a 16 slot anticollision request is processed, or sending a subsequent request (which could be again an inventory request).

T_{Fp3} starts from the time the RWD has generated the falling edge of the last sent EOF.

The minimum value of T_{Fp3} is $T_{Fp3min} = T_{Fp1max} + T_{FpSOF}$.

T_{FpSOF} is the time duration for a HITAG μ ISO 18000 transponder IC to transmit an SOF to the RWD.

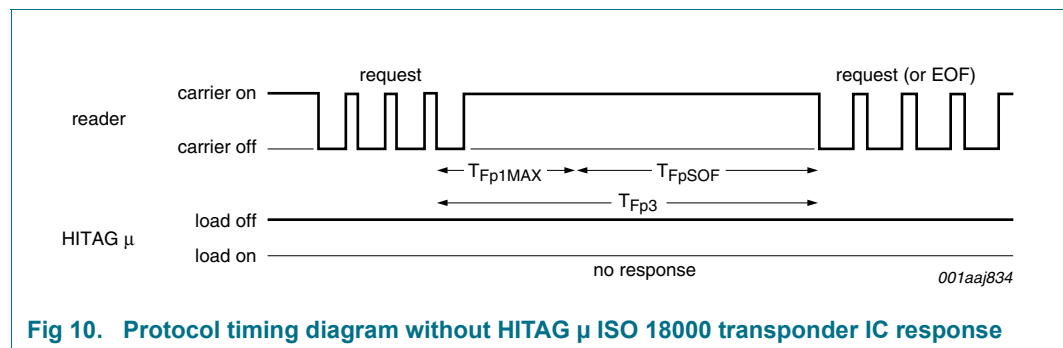

Fig 10. Protocol timing diagram without HITAG μ ISO 18000 transponder IC response

Table 7. Overview timing parameters [1]

Symbol	Min	Max
T_{FpSOF}	$3 \times T_{Fd}$	$3 \times T_{Fd}$
T_{Fp1}	$204 \times T_C$	$213 \times T_C$
T_{Fp2}	$150 \times T_C$	-
T_{Fp3}	$T_{Fp1max} + T_{FpSOF}$	-

[1] T_C ...Carrier period time ($1/125kHz = 8 \mu s$ nominal)

12. State diagram

12.1 General description of states

RF Off

The powering magnetic field is switched off or the HITAG μ ISO 18000 transponder IC is out of the field.

READY

The HITAG μ ISO 18000 transponder IC enters this state when it is activated by the RWD.

SELECTED

The HITAG μ ISO 18000 transponder IC enters the Selected state after receiving the SELECT command with a matching UII. In the Selected state the respective commands with SEL=1 are valid only for selected transponder.

Only one HITAG μ transponder IC should be in the selected state at one time. If one transponder is selected and a second transponder receives the SELECT Command, the first transponder will automatically change to Quiet state.

QUIET

The HITAG μ ISO 18000 transponder IC enters this state after receiving a STAY QUIET command or when he was in selected state and receives a SELECT command addressed to another transponder.

In this state, the HITAG μ transponder IC reacts to any request commandos where the ADR flag is set.

Remark:

In case of an invalid command the transponder will remain in his actual state.

12.2 State diagram HITAG μ ISO 18000

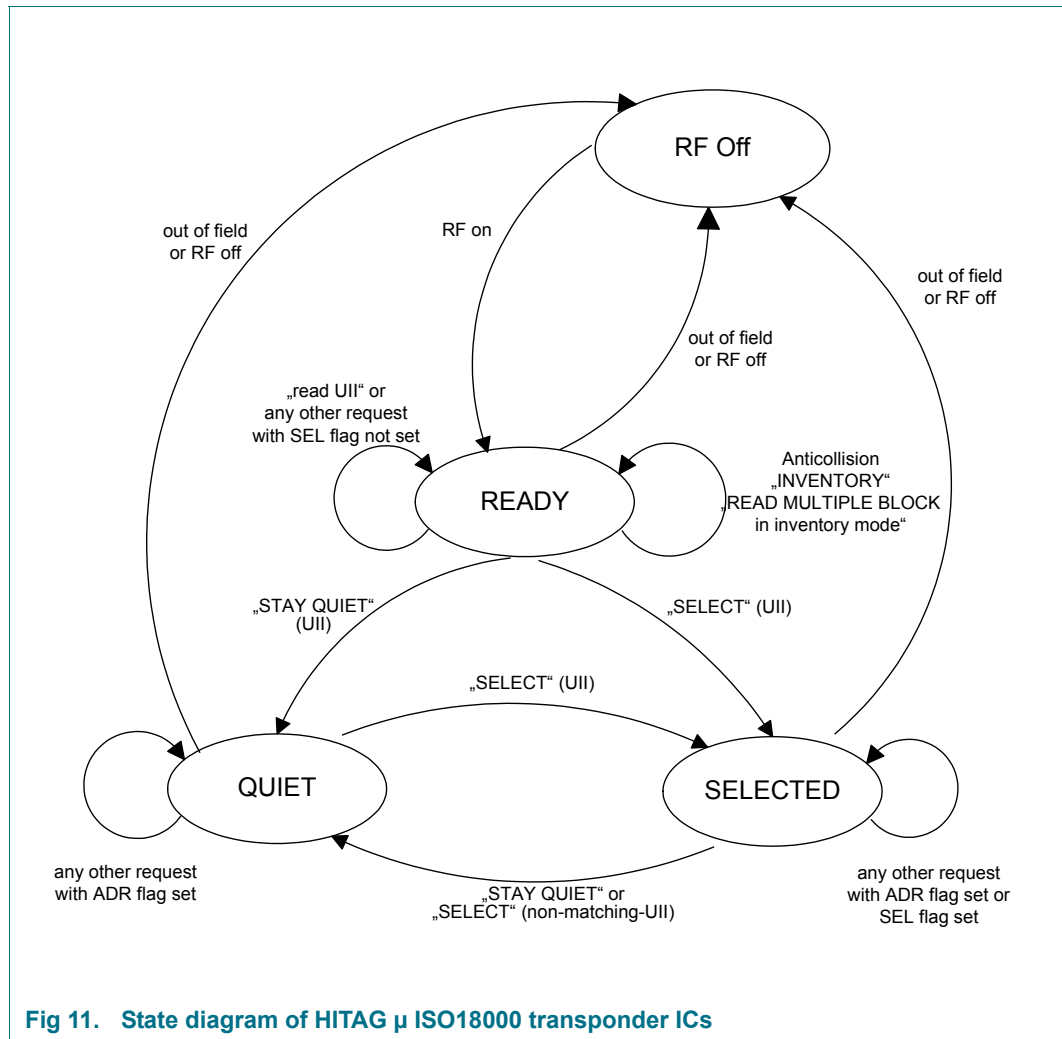

13. Modes

13.1 Anticollision

The RWD is the master of the communication with one or multiple transponder ICs. It starts the anticollision sequence by issuing the inventory request (see [Section 14.3](#)). Within the RWD command the NOS flag must be set to the desired setting (1 or 16 slots) and add the mask length and the mask value after the command field.

The mask length n indicates the number of significant bits of the mask value. It can have any value between 0 and 44 when 16 slots are used and any value between 0 and 48 when 1 slot is used.

The next two subsections summarize the actions done by the transponder IC during an inventory round.

13.1.1 Anticollision with 1 slot

The transponder IC will receive one or more inventory commands with NOS = '1'. Every time the transponder IC's fractional or whole UUI matches the mask value of RWD's request it responds with remaining UUI without mask value.

Transponder IC's responses are modulated by dual pattern data coding as described in [Section 10.2](#).

13.1.2 Anticollision with 16 slots

The transponder IC will receive several inventory commands with NOS = '0' defining an amount of 16 slots. Within the request there is the mask specified by length and value (sent LSB first).

In case of mask length = '0' the four least significant bits of transponder IC's UUI become the starting value of transponder IC's slot counter.

In case of mask length \neq '0' the received fractional mask is compared to transponder IC's UUI. If it matches the starting value for transponder IC's slot number will be calculated. Starting at last significant bit of the sent mask the next four less significant bits of UUI are used for this value. At the same time transponder IC's slot counter is reset to '0'.

Now the RWD begins its anticollision algorithm. Every time the transponder IC receives an EOF it increments slot-counter. Now if mask value and slot-counter value are matching the transponder IC responds with the remaining UUI without mask value but with slot number

In case of collision within one slot the RWD changes the mask value and starts again running its algorithm.

14. Command set

The first part of this section ([Section 14.1](#)) describes the flags used in every RWD command. The following subsections ([Section 14.3](#) until [Section 14.11](#)) explain all implemented commands and their suitable transponder IC responses which are done with tables showing the command itself and suitable responses.

Within tables flags, parameter bits and parts of a response written in braces are optional. That means if the suitable flag is set resulting transponder IC's action will be performed according to [Section 14.1](#).

Every command is embedded in SOF and EOF pattern. As described in [Table 8](#) and [Table 9](#) sending and receiving data is done with the least significant bit of every field on first position.

Important information:

In this document the fields (i.e. command codes) are written with most significant bit first.

Table 8. Reader - Transponder IC transmission [\[1\]](#)[\[2\]](#)

SOF	Flags	Commands	Parameters	Data	CRC-16	EOF
-	5	6	var.	var.	(16)	-
-	LSB ... MSB	LSB ... MSB	LSB ... MSB	LSB ... MSB	LSB ... MSB	-

[1] Values in braces are optional.

[2] Data is sent with least significant bit first.

Table 9. Transponder IC - Reader transmission [\[1\]](#)[\[2\]](#)

SOF	Error flag	Data/Error code	CRC-16	EOF
-	1	var.	(16)	-
-	-	LSB ... MSB	LSB ... MSB	-

[1] Values in braces are optional.

[2] Data is sent with least significant bit first.

14.1 Flags

Every request command contains five flags which are sent in order Bit 1 (LSB) to Bit 5 (MSB). The specific meaning depends on the context.

Table 10. Command Flags

Bit	Flag	Full name	Value	Description
1	PEXT	Protocol EXTension	0	No protocol format extension
			1	RFU
2	INV	INVenory	0	Flag 4 and Flag 5 are 'SEL' and 'ADR' Flag
			1	Flag 4 and Flag 5 are 'RFU' and 'NOS' Flag
3	CRCT	CRC-Transponder	0	Transponder IC respond without CRC
			1	Transponder IC respond contains CRC
4	SEL (INV==0)	SElect		in combination with ADR (see Table 12)
5	ADR (INV==0)	ADdRes		in combination with SEL (see Table 12)
4	AFI (INV==1)	Reserved for future use	0	AFI field is not present
			1	AFI field is present
5	NOS (INV==1)		0	16 slots while performing anti-collision
			1	1 slot while performing anti-collision

Table 11. Command Flags - Bit order

	MSB bit5	bit4	bit3	bit2	LSB bit1
INV==0	ADR	SEL	CRCT	INV	PEXT
INV==1	NOS	AFI	CRCT	INV	PEXT

Table 12. Meaning of ADR and SEL flag

ADR	SEL	Meaning
0	0	Request without UII, all transponder ICs in READY state shall respond
1	0	Request contains UII, one transponder IC (with corresponding UII) shall respond
0	1	Request without UII, the transponder IC in SELECTED state shall respond
1	1	Reserved for future use

14.2 Error handling

In case an error has been occurred the transponder IC responses with the set error flag and the three bit code '111' (meaning 'unknown error').

The general response format in case of an error response is shown in [Table 13](#) whereas commands not supporting error responses are excluded. In case of an unsupported command there will be no response. The format is embedded into SOF and EOF.

Table 13. Response format in error case

Error flag	Error code	CRC-16	Description
1	3	(16)	No. of bits
1	111		

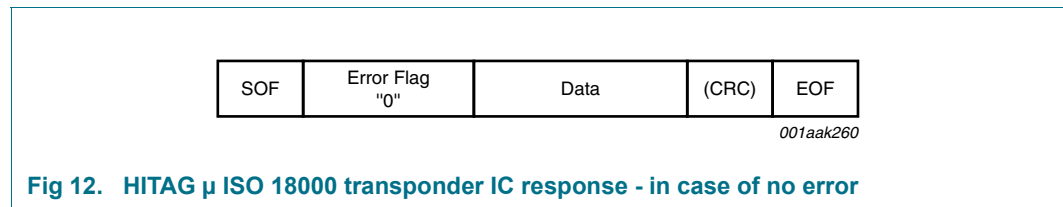

Fig 12. HITAG μ ISO 18000 transponder IC response - in case of no error

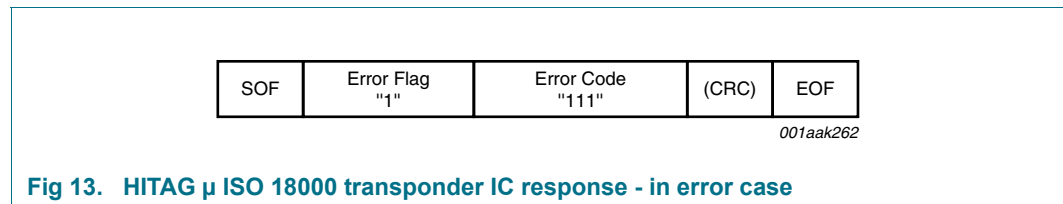

Fig 13. HITAG μ ISO 18000 transponder IC response - in error case

14.3 INVENTORY

Upon reception of this command without error, all transponder ICs in the ready state shall perform the anticollision sequence. The inventory (INV) flag shall be set to '1'. The NOS flag determines whether 1 or 16 slots are used.

If AFI flag is set to '1' the transponder handles the request as error.

If a transponder IC detects any error, it shall remain silent.

Table 14. INVENTORY - Request format (00h)

Flags	Command	Mask length	Mask value	CRC-16	Description
5	6	6	n	(16)	No. of bits
10(1)10	000000	$0 \leq n \leq$ UII length	UII Mask		AC with 1 timeslot
00(1)10	000000	$0 \leq n \leq$ UII length	UII Mask		AC with 16 timeslot

Table 15. Response to a successful INVENTORY request [1][2]

Error Flag	Data	CRC-16	Description
1	48 - n	(16)	No. of bits
0	Remaining UII without mask value		

[1] Error and CRC are Manchester coded, UII is dual pattern coded.

[2] Response within the according time slot.

Error Flag set to '0' indicates no error.

14.4 STAY QUIET

Upon reception of this command without error, a transponder IC in either ready state or selected state enters the quiet state and shall not send back a response.

The STAY QUIET command with both SEL and ADR flag set to '0' or both set to '1' is not allowed.

There is no response to the STAY QUIET request, even if the transponder detects an error.

Table 16. STAY QUIET - request format(01h)

Flags	Command	Data	CRC-16	Description
5	6	(48)	(16)	No. of bits:
01(1)00	000001	-		without UII
10(1)00	000001	UII		with UII

14.5 READ UII

Upon reception of this command without error all transponder ICs in the ready state are sending their UII.

The addressed (ADR), the select (SEL), the inventory (INV) and the (PEXT) flag are set to '0'.

Table 17. READ UII - request format (02h)

Flags	Command	CRC-16	Description
5	6	(16)	No. of bits
00(1)00	000010		

Table 18. Response to a successful READ UII request

Error flag	Data	CRC-16	Description
1	48	(16)	No. of bits
0	UII		

Error flag set to '0' indicates no error.

14.6 READ MULTIPLE BLOCK

Upon reception of this command without error, the transponder reads the requested block(s) and sends back their value in the response. The blocks are numbered from 0 to 255.

The number of blocks in the request is one less than the number of blocks that the transponder returns in its response i.e. a value of '6' in the 'Number of blocks' field requests to read 7 blocks. A value '0' requests to read a single block.

Table 19. READ MULTIPLE BLOCKS - request format (12h)

Flags	Command	Data 1	Data 2	Data 3	CRC-16	Description
5	6	(48)	8	8	(16)	No. of bits
00(1)00	010010	-	First block number	Number of blocks		without Ull in READY state
10(1)00	010010	Ull	First block number	Number of blocks		with Ull
01(1)00	010010	-	First block number	Number of blocks		without Ull in SELECTED state

Table 20. Response to a successful READ MULTIPLE BLOCKS request

Error Flag	Data	CRC-16	Description
1	32 x Number of blocks	(16)	No. of bits
0	User memory block data		

Error Flag set to '0' indicates no error.

14.6.1 READ MULTIPLE BLOCKS in INVENTORY mode

The READ MULTIPLE BLOCK command can also be sent in inventory mode (which is marked by INV-Flag = '1' within the request). Here request and response will change as shown in following tables.

If the transponder detects an error during the inventory sequence, it shall remain silent.

Table 21. READ MULTIPLE BLOCKS - request format (12h)

Flags	Command	Mask length	Mask value	Parameter 1	Parameter 2	CRC-16	Description
5	6	6	n	8	8	(16)	No. of bits
10(1)10	010010	$0 \leq n \leq$ UID length		First block number	Number of blocks		AC with 1 timeslot
00(1)10	010010	$0 \leq n \leq$ UID length		First block number	Number of blocks		AC with 16 timeslot

After receiving RWD's command without error the transponder IC transmits the remaining section of the UID in dual pattern code. The following data (Error Flag, Data 2, optional CRC in no error case; Error Flag, Error Code, optional CRC in error case) is transmitted in Manchester Code.

Table 22. READ MULTIPLE BLOCKS in INVENTORY mode Response format [1]

Error Flag	Data 1	Data 2	CRC-16	Description
1	48 - n	32 x number of blocks	(16)	No.of bits
0	Remaining section of UID (without mask value)	User memory block data		

[1] Error, CRC and Data are Manchester coded, UID is dual pattern coded.

14.7 WRITE SINGLE BLOCK

Upon reception of this command without error, the transponder IC writes 32-bit of data into the requested user memory block and report the success of the operation in the response.

Table 23. WRITE SINGLE BLOCK - request format (14h)

Flags	Command	Data 1	Data 2	Data 3	CRC-16	Description
5	6	(48)	8	32	(16)	No. of bits
00(1)00	010100	-	block number	block data		without Ull in READY state
10(1)00	010100	Ull	block number	block data		with Ull
01(1)00	010100	-	block number	block data		without Ull in SELECTED state

Table 24. Response to a successful WRITE SINGLE BLOCK request

Error Flag	CRC-16	Description
1	(16)	No. of bits
0		

Error Flag set to '0' indicates no error.

14.8 LOCK BLOCK

Upon reception of this command without error, the transponder IC is write locking the requested block (block size = 32-bit) permanently.

Blocks within the block address range from 00h to 18h as well as FEh and FFh can be locked individually.

A LOCK BLOCK command with a block number value between 19h to 36h will lock all blocks within the block address range 19h to 36h.

In case a password is applied to the memory a lock is only possible after a successful login.

Table 25. LOCK BLOCK - request format (16h)

Flags	Command	Data 1	Data 2	CRC-16	Description
5	6	(48)	8	(16)	No. of bits
00(1)00	010110	-	block number		without Ull in READY state
10(1)00	010110	Ull	block number		with Ull
01(1)00	010110	-	block number		without Ull in SELECTED state

Table 26. Response to a successful LOCK BLOCK request

Error flag	CRC-16	Description
1	(16)	No. of bits
0		

Error Flag set to '0' indicates no error.

14.9 SELECT

The SELECT command is always be executed with SEL flag set to '0' and ADR flag set to '1'. There are several possibilities upon reception of this command without error:

- If the UII, received by the transponder IC, is equal to its own UII, the transponder IC enters the Selected state and shall send a response.
- If the received UII is different there are two possibilities
 - A transponder IC in a non-selected state (QUIET or READY) is keeping its state and not sending a response.
 - The transponder IC in the Selected state enters the Quiet state and does not send a response.

Table 27. SELECT - request format (18h)

Flags	Command	Data 1	CRC-16	Description
5	6	48	(16)	No. of bits
10(1)00	011000	UII		

Table 28. Response to a successful SELECT request

Error flag	CRC-16	Description
1	(16-bit)	No. of bits
0		

Error Flag set to '0' indicates no error.

14.10 GET SYSTEM INFORMATION

Upon reception of this command without error, the transponder IC reads the requested system memory block(s) and sends back their values in the response.

Table 29. GET SYSTEM INFORMATION - request format (17h)

Flags	Command	Data 1	CRC-16	Description
5	6	(48)	(16)	No. of bits
00(1)00	010111			without Ull
10(1)00	010111	Ull		with Ull

Table 30. GET SYSTEM INFORMATION - response format

Error flag	Data	CRC-16	Description
1	40 8 8 8 8 8 8 8 8 8	(16)	No. of bits
0	system memory block data		
	MSN MFC ICR 0 0 0 0 0 0		

Error Flag set to '0' indicates no error.

14.11 LOGIN

Upon reception of this command without error, the transponder IC compares received password with PWD in memory block (FEh) and if correct it permits write (opt. read) access to the protected memory area (defined in User config, see [Table 4](#)) and reports the success of the operation in the response. In case a wrong password is issued in a further login request no access to protected memory blocks will be granted.

Default password: FFFFFFFFh

Table 31. LOGIN - request format

Flags	Command	IC MFC	Parameter 1	Password	CRC-16	Description
5	6	8	(48)	32	(16)	No. of bits
00(1)00	101000	MFC	-	password		without UII in READY state
10(1)00	101000	MFC	UII	password		with UII
01(1)00	101000	MFC	-	password		without UII in SELECTED state

Table 32. Response to a successful LOGIN request

Error flag	CRC-16	Description
1	(16)	No. of bits
0		

15. Data integrity/calculation of CRC

The following explanations show the features of the HITAG μ protocol to protect read and write access to transponders from undetected errors. The CRC is an 16-bit CRC according to ISO 11784/11785.

15.1 Data transmission: RWD to HITAG μ ISO 18000 transponder IC

Data stream transmitted by the RWD to the HITAG μ ISO 18000 transponder may include an optional 16-bit Cyclic Redundancy Check (CRC-16).

The data stream is first verified for data errors by the HITAG μ ISO 18000 transponder IC and then executed.

The generator polynomial for the CRC-16 is:

$$u^{16} + u^{12} + u^5 + 1 = 1021h$$

The CRC pre set value is: 0000h

15.2 Data transmission: HITAG μ ISO 18000 transponder IC to RWD

The HITAG μ ISO 18000 transponder IC calculates the CRC on all received bits of the request. Whether the HITAG μ ISO 18000 transponder IC calculated CRC is appended to the response depends on the setting of the CRCT flag.

16. Limiting values

Table 33. Limiting values^{[1][2]}

In accordance with the Absolute Maximum Rating System (IEC 60134).

Symbol	Parameter	Conditions	Min	Max	Unit
T _{stg}	storage temperature		-55	+125	°C
V _{ESD}	electrostatic discharge voltage	JEDEC JESD 22-A114-AB Human Body Model	±2	-	kV
I _{i(max)}	maximum input current	IN1-IN2	-	±20	mA _{peak}
T _j	junction temperature		-40	+85	°C

- [1] Stresses above those listed under Absolute Maximum Ratings may cause permanent damage to the device. This is a stress rating only and functional operation of the device at these or any conditions other than those described in the Operating Conditions and Electrical Characteristics section of this specification is not implied.
- [2] This product includes circuitry specifically designed for the protection of its internal devices from the damaging effects of excessive static charge. Nonetheless, it is suggested that conventional precautions should be taken to avoid applying values greater than the rated maxima

17. Characteristics

Table 34. Characteristics

Symbol	Parameter	Conditions	Min	Typ	Max	Unit
f _{oper}	operating frequency		100	125	150	kHz
V _{IN1-IN2}	input voltage		4	5	6	V _{peak}
I _I	input current	IN1-IN2	-	-	±10	mA _{peak}
C _i	input capacitance between IN1-IN2	V _{IN1-IN2} = 0.5 V _{rms} ^{[2][3]}	203.7	210	216.3	pF
C _i	input capacitance between IN1-IN2	V _{IN1-IN2} = 0.5 V _{rms} ^{[2][4]}	266	280	294	pF

- [1] Typical ratings are not guaranteed. Values are at 25 °C.
- [2] Measured with an HP4285A LCR meter at 125 kHz/room temperature (25 °C)
- [3] Integrated Resonance Capacitor: 210pF ±3%
- [4] Integrated Resonance Capacitor: 280pF ±5%

18. Marking

18.1 Marking SOT1122

Table 35. Marking SOT1122

Type	Type code
HTMS1301FTB/AF	13
HTMS8301FTB/AF	83

Table 36. Pin description SOT1122

Pin	Description
1	IN 1
2	IN 2
3	n.c not connected

18.2 Marking HVSON2

Only two lines are available for marking ([Figure 14](#)).

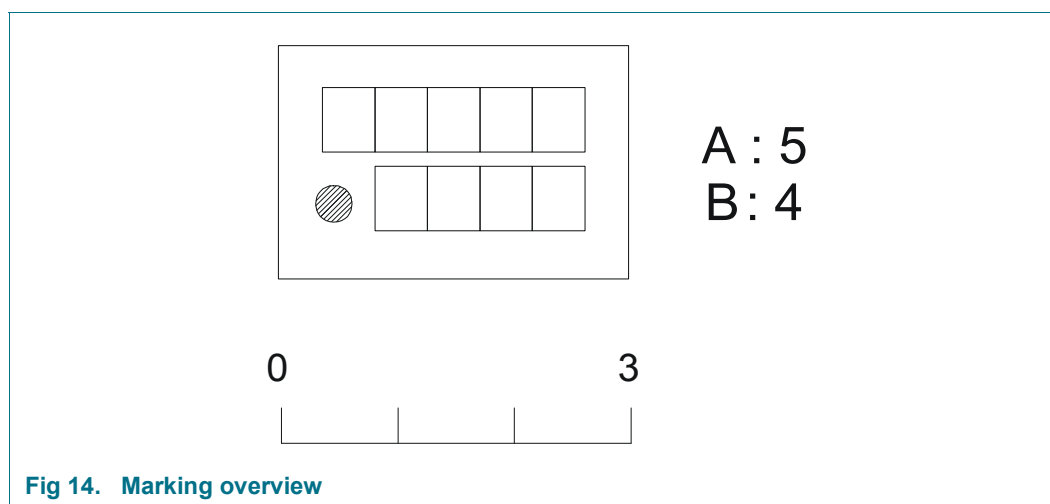

First line consists on five digits and contains the diffusion lot number. Second line consists on four digits and describes the product type, HTSH5601ETK or HTSH4801ETK (see example in [Table 37](#)).

Table 37. Marking example

Line	Marking	Description
A	70960	5 digits, Diffusion Lot Number, First letter truncated
B	HM10	4 digits, Type: Table 38 "Marking HVSON2"

Table 38. Marking HVSON2

Type	Type code
HTMS1301FTK/AF	HM13
HTMS8301FTK/AF	HM82

19. Package outline

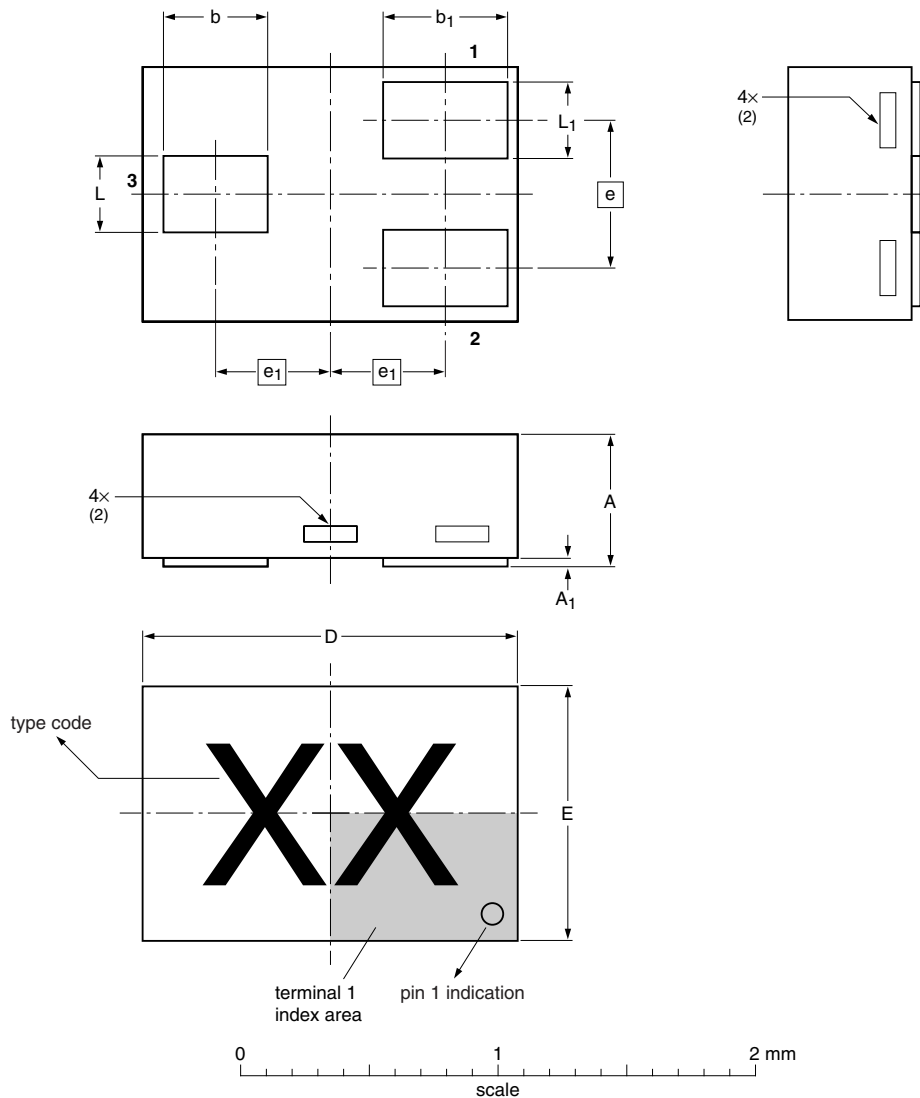

Dimensions

Unit	A ⁽¹⁾	A ₁	b	b ₁	D	E	e	e ₁	L	L ₁
max	0.50	0.04	0.45	0.55	1.50	1.05			0.35	0.30
nom			0.40	0.50	1.45	1.00	0.55	0.425	0.30	0.25
min			0.37	0.47	1.40	0.95			0.27	0.22

Notes

Dimension A is including plating thickness.
Can be visible in some manufacturing processes.

sot1122

Outline version	References			European projection	Issue date
	IEC	JEDEC	JEITA		

Fig 15. Package outline SOT1122

HVSON2: plastic thermal enhanced very thin small outline package; no leads;
2 terminals; body $3 \times 2 \times 0.85$ mm

SOT899-1

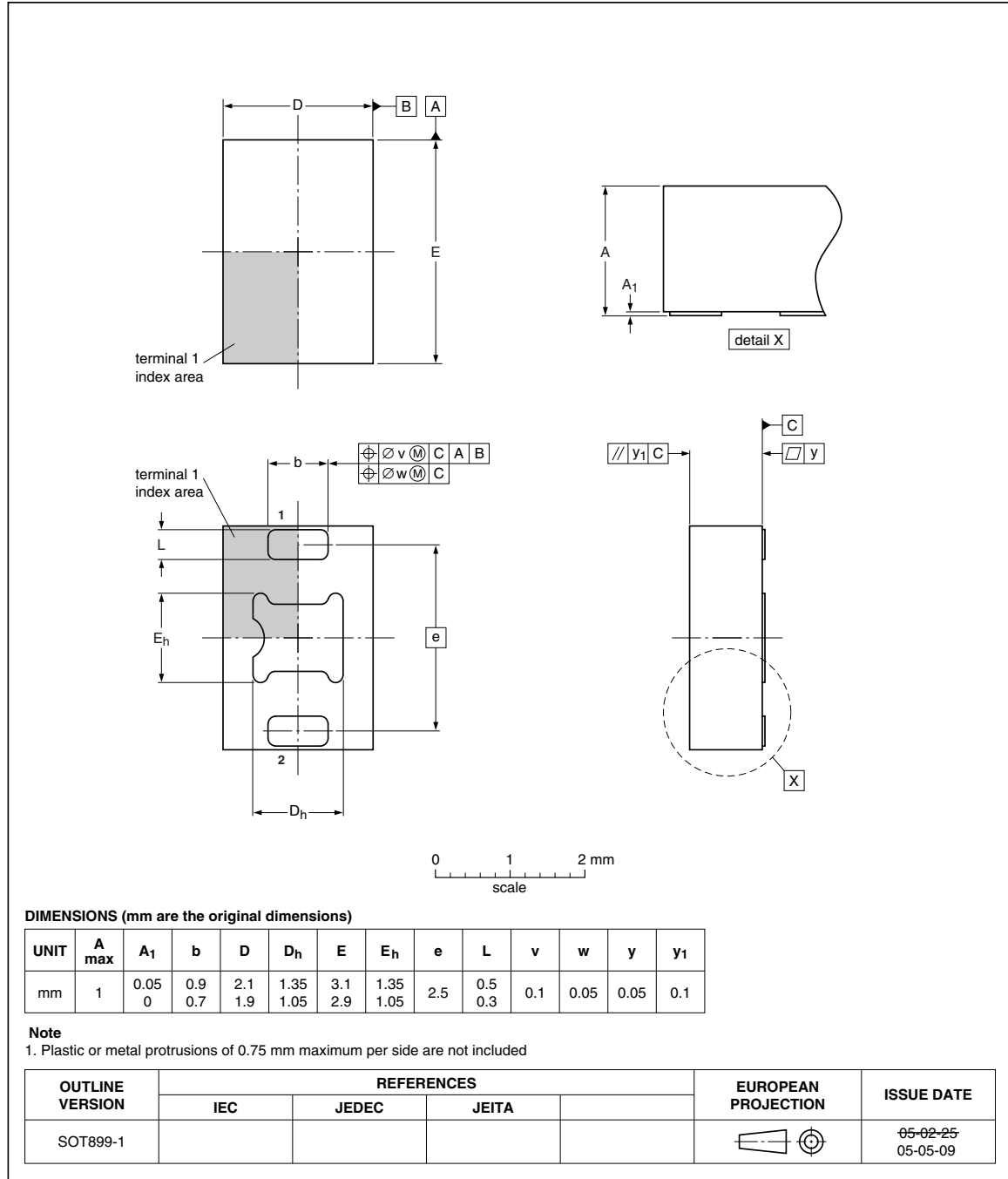

Fig 16. Package outline HVSON2

20. Abbreviations

Table 39. Abbreviations

Abbreviation	Definition
AC	Anticollision Code
AFI	Application Family Identifier
ASK	Amplitude Shift Keying
BC	Bi-phase Code
BPLC	Binary Pulse Length Coding
CRC	Cyclic Redundancy Check
DSFID	Data Storage Format Identifier
EEPROM	Electrically Erasable Programmable Memory
EOF	End Of Frame
ICR	Integrated Circuit Reference number
LSB	Least Significant Bit
LSByte	Least Significant Byte
m	Modulation Index
MC	Manchester Code
MFC	integrated circuit Manufacturer Code
MSB	Most Significant Bit
MSByte	Most Significant Byte
MSN	Manufacturer Serial Number
NA	No Access
NOB	Number Of Block
NOP	Number Of Pages
NOS	Number Of Slots
NSS	Number Of Sensors
OTP	One Time Programmable
PID	Product Identifier
PWD	Password
RFU	Reserved for Future Use
RND	Random Number
RO	Read Only
RTF	Reader Talks First
R/W	Read/Write
RWD	Read/Write Device
SOF	Start of Frame
UII	Unique Item Identifier

21. References

- [1] **Application note** — AN10214, HITAG Coil Design Guide, Transponder IC
BL-ID Doc.No.: 0814**1
- [2] **General specification for 8" wafer on UV-tape with electronic fail die marking** — Delivery type description, BL-ID Doc.No.: 1093**1

1. ** ... document version number

22. Revision history

Table 40: Revision history

Document ID	Release date	Data sheet status	Change notice	Supersedes
184430	20100318	Product data sheet	-	-

23. Legal information

23.1 Data sheet status

Document status ^{[1][2]}	Product status ^[3]	Definition
Objective [short] data sheet	Development	This document contains data from the objective specification for product development.
Preliminary [short] data sheet	Qualification	This document contains data from the preliminary specification.
Product [short] data sheet	Production	This document contains the product specification.

[1] Please consult the most recently issued document before initiating or completing a design.

[2] The term 'short data sheet' is explained in section "Definitions".

[3] The product status of device(s) described in this document may have changed since this document was published and may differ in case of multiple devices. The latest product status information is available on the Internet at URL <http://www.nxp.com>.

23.2 Definitions

Draft — The document is a draft version only. The content is still under internal review and subject to formal approval, which may result in modifications or additions. NXP Semiconductors does not give any representations or warranties as to the accuracy or completeness of information included herein and shall have no liability for the consequences of use of such information.

Short data sheet — A short data sheet is an extract from a full data sheet with the same product type number(s) and title. A short data sheet is intended for quick reference only and should not be relied upon to contain detailed and full information. For detailed and full information see the relevant full data sheet, which is available on request via the local NXP Semiconductors sales office. In case of any inconsistency or conflict with the short data sheet, the full data sheet shall prevail.

Product specification — The information and data provided in a Product data sheet shall define the specification of the product as agreed between NXP Semiconductors and its customer, unless NXP Semiconductors and customer have explicitly agreed otherwise in writing. In no event however, shall an agreement be valid in which the NXP Semiconductors product is deemed to offer functions and qualities beyond those described in the Product data sheet.

23.3 Disclaimers

Limited warranty and liability — Information in this document is believed to be accurate and reliable. However, NXP Semiconductors does not give any representations or warranties, expressed or implied, as to the accuracy or completeness of such information and shall have no liability for the consequences of use of such information.

In no event shall NXP Semiconductors be liable for any indirect, incidental, punitive, special or consequential damages (including - without limitation - lost profits, lost savings, business interruption, costs related to the removal or replacement of any products or rework charges) whether or not such damages are based on tort (including negligence), warranty, breach of contract or any other legal theory.

Notwithstanding any damages that customer might incur for any reason whatsoever, NXP Semiconductors' aggregate and cumulative liability towards customer for the products described herein shall be limited in accordance with the *Terms and conditions of commercial sale* of NXP Semiconductors.

Right to make changes — NXP Semiconductors reserves the right to make changes to information published in this document, including without limitation specifications and product descriptions, at any time and without notice. This document supersedes and replaces all information supplied prior to the publication hereof.

Suitability for use — NXP Semiconductors products are not designed, authorized or warranted to be suitable for use in medical, military, aircraft, space or life support equipment, nor in applications where failure or

malfunction of an NXP Semiconductors product can reasonably be expected to result in personal injury, death or severe property or environmental damage. NXP Semiconductors accepts no liability for inclusion and/or use of NXP Semiconductors products in such equipment or applications and therefore such inclusion and/or use is at the customer's own risk.

Applications — Applications that are described herein for any of these products are for illustrative purposes only. NXP Semiconductors makes no representation or warranty that such applications will be suitable for the specified use without further testing or modification.

NXP Semiconductors does not accept any liability related to any default, damage, costs or problem which is based on a weakness or default in the customer application/use or the application/use of customer's third party customer(s) (hereinafter both referred to as "Application"). It is customer's sole responsibility to check whether the NXP Semiconductors product is suitable and fit for the Application planned. Customer has to do all necessary testing for the Application in order to avoid a default of the Application and the product. NXP Semiconductors does not accept any liability in this respect.

Limiting values — Stress above one or more limiting values (as defined in the Absolute Maximum Ratings System of IEC 60134) will cause permanent damage to the device. Limiting values are stress ratings only and (proper) operation of the device at these or any other conditions above those given in the Recommended operating conditions section (if present) or the Characteristics sections of this document is not warranted. Constant or repeated exposure to limiting values will permanently and irreversibly affect the quality and reliability of the device.

Terms and conditions of commercial sale — NXP Semiconductors products are sold subject to the general terms and conditions of commercial sale, as published at <http://www.nxp.com/profile/terms>, unless otherwise agreed in a valid written individual agreement. In case an individual agreement is concluded only the terms and conditions of the respective agreement shall apply. NXP Semiconductors hereby expressly objects to applying the customer's general terms and conditions with regard to the purchase of NXP Semiconductors products by customer.

No offer to sell or license — Nothing in this document may be interpreted or construed as an offer to sell products that is open for acceptance or the grant, conveyance or implication of any license under any copyrights, patents or other industrial or intellectual property rights.

Export control — This document as well as the item(s) described herein may be subject to export control regulations. Export might require a prior authorization from national authorities.

Quick reference data — The Quick reference data is an extract of the product data given in the Limiting values and Characteristics sections of this document, and as such is not complete, exhaustive or legally binding.

Non-automotive qualified products — Unless this data sheet expressly states that this specific NXP Semiconductors product is automotive qualified, the product is not suitable for automotive use. It is neither qualified nor tested in accordance with automotive testing or application requirements. NXP Semiconductors accepts no liability for inclusion and/or use of non-automotive qualified products in automotive equipment or applications.

In the event that customer uses the product for design-in and use in automotive applications to automotive specifications and standards, customer (a) shall use the product without NXP Semiconductors' warranty of the product for such automotive applications, use and specifications, and (b) whenever customer uses the product for automotive applications beyond NXP Semiconductors' specifications such use shall be solely at customer's own risk, and (c) customer fully indemnifies NXP Semiconductors for any liability, damages or failed product claims resulting from customer design and use of the product for automotive applications beyond NXP Semiconductors' standard warranty and NXP Semiconductors' product specifications.

23.4 Licenses

ICs with HITAG functionality

NXP Semiconductors owns a worldwide perpetual license for the patents US 5214409, US 5499017, US 5235326 and for any foreign counterparts or equivalents of these patents. The license is granted for the Field-of-Use covering: (a) all non-animal applications, and (b) any application for animals raised for human consumption (including but not limited to dairy animals), including without limitation livestock and fish.

Please note that the license does not include rights outside the specified Field-of-Use, and that NXP Semiconductors does not provide indemnity for the foregoing patents outside the Field-of-Use.

23.5 Trademarks

Notice: All referenced brands, product names, service names and trademarks are the property of their respective owners.

HITAG — is a trademark of NXP B.V.

24. Contact information

For more information, please visit: <http://www.nxp.com>

For sales office addresses, please send an email to: salesaddresses@nxp.com

25. Tables

Table 1.	Ordering information	2	Table 22.	READ MULTIPLE BLOCKS in INVENTORY mode Response format [1]	26
Table 2.	HITAG μ ISO 18000 - Mega bumps dimensions	4	Table 23.	WRITE SINGLE BLOCK - request format (14h)	27
Table 3.	Memory organization	7	Table 24.	Response to a successful WRITE SINGLE BLOCK request	27
Table 4.	User configuration block to Byte0	8	Table 25.	LOCK BLOCK - request format (16h)	28
Table 5.	Modulation coding times [1][2]	9	Table 26.	Response to a successful LOCK BLOCK request	28
Table 6.	Data coding times [1]	10	Table 27.	SELECT - request format (18h)	29
Table 7.	Overview timing parameters [1]	16	Table 28.	Response to a successful SELECT request	29
Table 8.	Reader - Transponder IC transmission [1][2]	20	Table 29.	GET SYSTEM INFORMATION - request format (17h)	30
Table 9.	Transponder IC - Reader transmission [1][2]	20	Table 30.	GET SYSTEM INFORMATION - response format	30
Table 10.	Command Flags	21	Table 31.	LOGIN - request format	31
Table 11.	Command Flags - Bit order	21	Table 32.	Response to a successful LOGIN request	31
Table 12.	Meaning of ADR and SEL flag	21	Table 33.	Limiting values [1][2]	33
Table 13.	Response format in error case	22	Table 34.	Characteristics	33
Table 14.	INVENTORY - Request format (00h)	23	Table 35.	Marking SOT1122	34
Table 15.	Response to a successful INVENTORY request [1][2]	23	Table 36.	Pin description SOT1122	34
Table 16.	STAY QUIET - request format(01h)	23	Table 37.	Marking example	34
Table 17.	READ UII - request format (02h)	24	Table 38.	Marking HVSON2	34
Table 18.	Response to a successful READ UII request	24	Table 39.	Abbreviations	37
Table 19.	READ MULTIPLE BLOCKS - request format (12h)	25	Table 40.	Revision history	39
Table 20.	Response to a successful READ MULTIPLE BLOCKS request	25			
Table 21.	READ MULTIPLE BLOCKS - request format (12h)	26			

26. Figures

Fig 1.	Block diagram of HITAG μ ISO 18000 transponder IC	3
Fig 2.	HITAG μ ISO 1800 - Mega bumps bondpad locations	4
Fig 3.	Modulation details of data transmission from RWD to HITAG μ transponder IC	9
Fig 4.	Reader to HITAG μ ISO 18000 transponder IC: Pulse Interval Encoding	10
Fig 5.	Start of frame pattern	11
Fig 6.	End of frame pattern	11
Fig 7.	HITAG μ ISO 18000 transponder IC - Load modulation coding	12
Fig 8.	Start of fame pattern	13
Fig 9.	General protocol timing diagram	14
Fig 10.	Protocol timing diagram without HITAG μ ISO 18000 transponder IC response	16
Fig 11.	State diagram of HITAG μ ISO18000 transponder ICs	18
Fig 12.	HITAG μ ISO 18000 transponder IC response - in case of no error	22
Fig 13.	HITAG μ ISO 18000 transponder IC response - in error case	22
Fig 14.	Marking overview	34
Fig 15.	Package outline SOT1122	35
Fig 16.	Package outline HVSON2	36

27. Contents

1	General description	1	11.3.1	RWD started to receive one or more HITAG μ ISO 18000 transponder IC responses	15
2	Features and benefits	1	11.3.2	RWD receives no HITAG μ ISO 18000 transponder IC response	16
2.1	Features	1	12	State diagram	17
2.2	Protocol	1	12.1	General description of states	17
2.3	Memory	2	12.2	State diagram HITAG μ ISO 18000	18
2.4	Supported standards	2	13	Modes	19
2.5	Security features	2	13.1	Anticollision	19
2.6	Delivery types	2	13.1.1	Anticollision with 1 slot	19
3	Applications	2	13.1.2	Anticollision with 16 slots	19
4	Ordering information	2	14	Command set	20
5	Block diagram	3	14.1	Flags	21
6	Pinning information	4	14.2	Error handling	22
7	Mechanical specification	5	14.3	INVENTORY	23
7.1	Wafer specification	5	14.4	STAY QUIET	23
7.1.1	Wafer	5	14.5	READ UII	24
7.1.2	Wafer backside	5	14.6	READ MULTIPLE BLOCK	25
7.1.3	Chip dimensions	5	14.6.1	READ MULTIPLE BLOCKS in INVENTORY mode	26
7.1.4	Passivation on front	5	14.7	WRITE SINGLE BLOCK	27
7.1.5	Au bump	6	14.8	LOCK BLOCK	28
7.1.6	Fail die identification	6	14.9	SELECT	29
7.1.7	Map file distribution	6	14.10	GET SYSTEM INFORMATION	30
8	Functional description	7	14.11	LOGIN	31
8.1	Memory organization	7	15	Data integrity/calculation of CRC	32
8.1.1	Memory organization	7	15.1	Data transmission: RWD to HITAG μ ISO 18000 transponder IC	32
8.2	Memory configuration	8	15.2	Data transmission: HITAG μ ISO 18000 transponder IC to RWD	32
9	General requirements	8	16	Limiting values	33
10	HITAG m ISO 18000 transponder IC air interface	9	17	Characteristics	33
10.1	Downlink communication signal interface - RWD to HITAG m ISO 18000 transponder IC	9	18	Marking	34
10.1.1	Modulation parameters	9	18.1	Marking SOT1122	34
10.1.2	Data rate and data coding	10	18.2	Marking HVSON2	34
10.1.3	RWD - Start of frame pattern	11	19	Package outline	35
10.1.4	RWD - End of frame pattern	11	20	Abbreviations	37
10.2	Communication signal interface - HITAG μ ISO 18000 transponder IC to RWD	12	21	References	38
10.2.1	Data rate and data coding	12	22	Revision history	39
10.2.2	Start of frame pattern	13	23	Legal information	40
10.2.3	End of frame pattern	13	23.1	Data sheet status	40
11	General protocol timing specification	14	23.2	Definitions	40
11.1	Waiting time before transmitting a response after an EOF from the RWD	14	23.3	Disclaimers	40
11.2	RWD waiting time before sending a subsequent request	15	23.4	Licenses	41
11.3	RWD waiting time before switching to next inventory slot	15	23.5	Trademarks	41

continued >>

24	Contact information	41
25	Tables	42
26	Figures	42
27	Contents	43

Please be aware that important notices concerning this document and the product(s) described herein, have been included in section 'Legal information'.

© NXP B.V. 2010.

All rights reserved.

For more information, please visit: <http://www.nxp.com>

For sales office addresses, please send an email to: salesaddresses@nxp.com

Date of release: 18 March 2010

184430