

SSTUB32865

1.8 V 28-bit 1 : 2 registered buffer with parity for DDR2-800
RDIMM applications

Rev. 03 — 27 March 2007

Product data sheet

1. General description

The SSTUB32865 is a 1.8 V 28-bit 1 : 2 register specifically designed for use on two rank by four (2R × 4) and similar high-density Double Data Rate 2 (DDR2) memory modules. It is similar in function to the JEDEC-standard 14-bit DDR2 register, but integrates the functionality of the normally required two registers in a single package, thereby freeing up board real-estate and facilitating routing to accommodate high-density Dual In-line Memory Module (DIMM) designs.

The SSTUB32865 also integrates a parity function, which accepts a parity bit from the memory controller, compares it with the data received on the D-inputs and indicates whether a parity error has occurred on its open-drain $\overline{\text{PTYERR}}$ pin (active LOW).

It further offers added features over the JEDEC standard register in that it can be configured for normal or high output drive strength, simply by tying input pin SELDR either HIGH or LOW as needed. This allows use in different module designs varying from low to high density designs by picking the appropriate drive strength to match net loading conditions. Furthermore, the SSTUB32865 features two additional chip select inputs, which allow more versatile enabling and disabling in densely populated memory modules. Both added features (drive strength and chip selects) are fully backward compatible to the JEDEC standard register.

The SSTUB32865 is packaged in a 160-ball, 12 × 18 grid, 0.65 mm ball pitch, thin profile fine-pitch ball grid array (TFBGA) package, which, while requiring a minimum 9 mm × 13 mm of board space, allows for adequate signal routing and escape using conventional card technology.

2. Features

- 28-bit data register supporting DDR2
- Fully compliant to JEDEC standard for SSTUB32865
- Supports 2 rank by 4 DIMM density by integrating equivalent functionality of two JEDEC-standard DDR2 registers (that is, 2 × SSTUB32864 or 2 × SSTUB32866)
- Parity checking function across 22 input data bits
- Parity out signal
- Controlled multi-impedance output impedance drivers enable optimal signal integrity and speed
- Meets or exceeds SSTUB32865 JEDEC standard speed performance
- Supports up to 450 MHz clock frequency of operation
- Programmable for normal or high output drive
- Optimized pinout for high-density DDR2 module design

- Chip-selects minimize power consumption by gating data outputs from changing state
- Two additional chip select inputs allow optional flexible enabling and disabling
- Supports Stub Series Terminated Logic SSTL_18 data inputs
- Differential clock (CK and \overline{CK}) inputs
- Supports LVCMOS switching levels on the control and \overline{RESET} inputs
- Single 1.8 V supply operation (1.7 V to 2.0 V)
- Available in 160-ball 9 mm × 13 mm, 0.65 mm ball pitch TFBGA package

3. Applications

- 400 MT/s to 800 MT/s high-density (for example, 2 rank by 4) DDR2 registered DIMMs
- DDR2 Registered DIMMs (RDIMM) desiring parity checking functionality

4. Ordering information

Table 1. Ordering information

Type number	Solder process	Package		
		Name	Description	Version
SSTUB32865ET/G	Pb-free (SnAgCu solder ball compound)	TFBGA160	plastic thin fine-pitch ball grid array package; 160 balls; body 9 × 13 × 0.7 mm	SOT802-2
SSTUB32865ET/S	Pb-free (SnAgCu solder ball compound)	TFBGA160	plastic thin fine-pitch ball grid array package; 160 balls; body 9 × 13 × 0.7 mm	SOT802-2

4.1 Ordering options

Table 2. Ordering options

Type number	Temperature range
SSTUB32865ET/G	T _{amb} = 0 °C to +70 °C
SSTUB32865ET/S	T _{amb} = 0 °C to +85 °C

5. Functional diagram

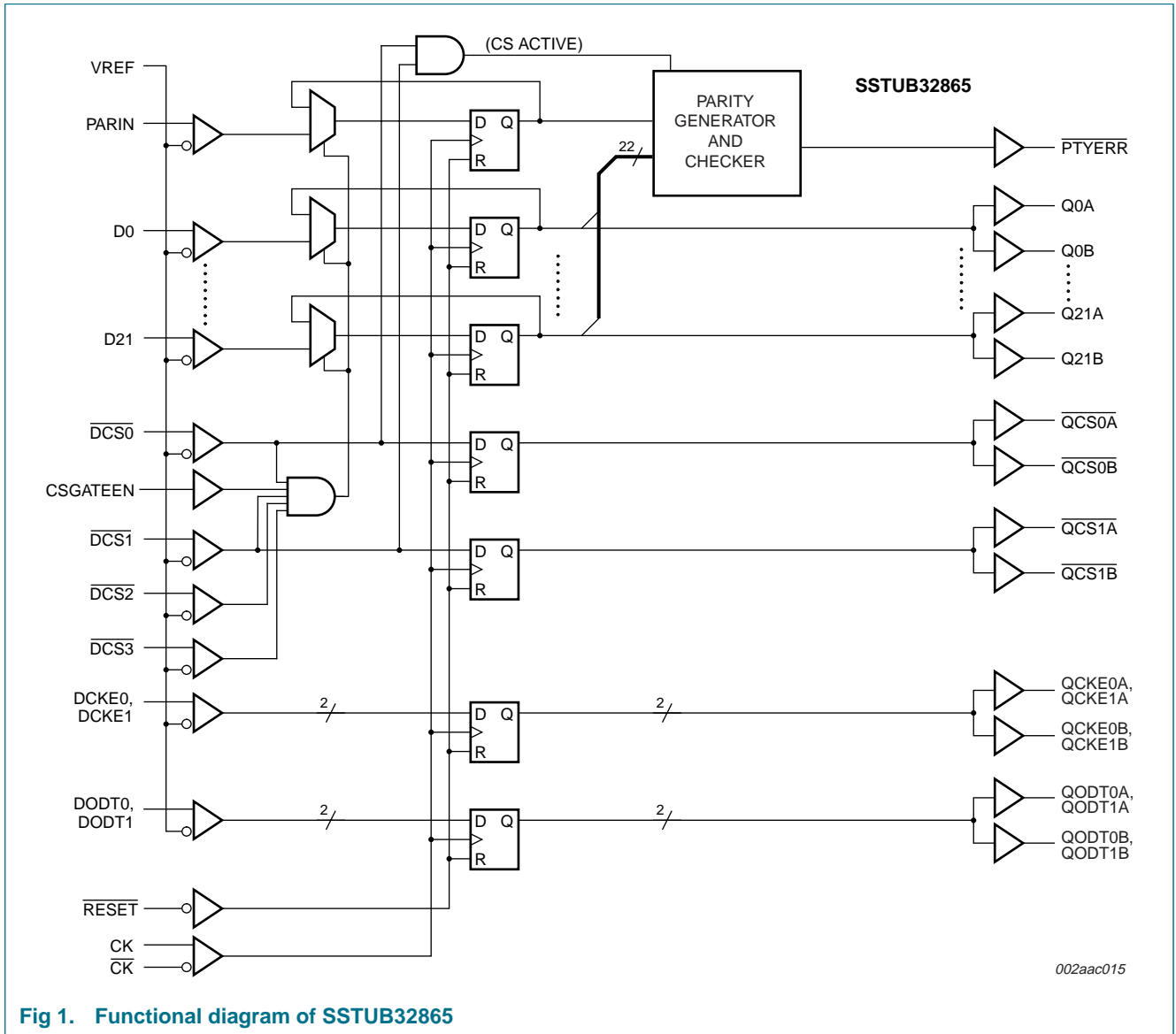
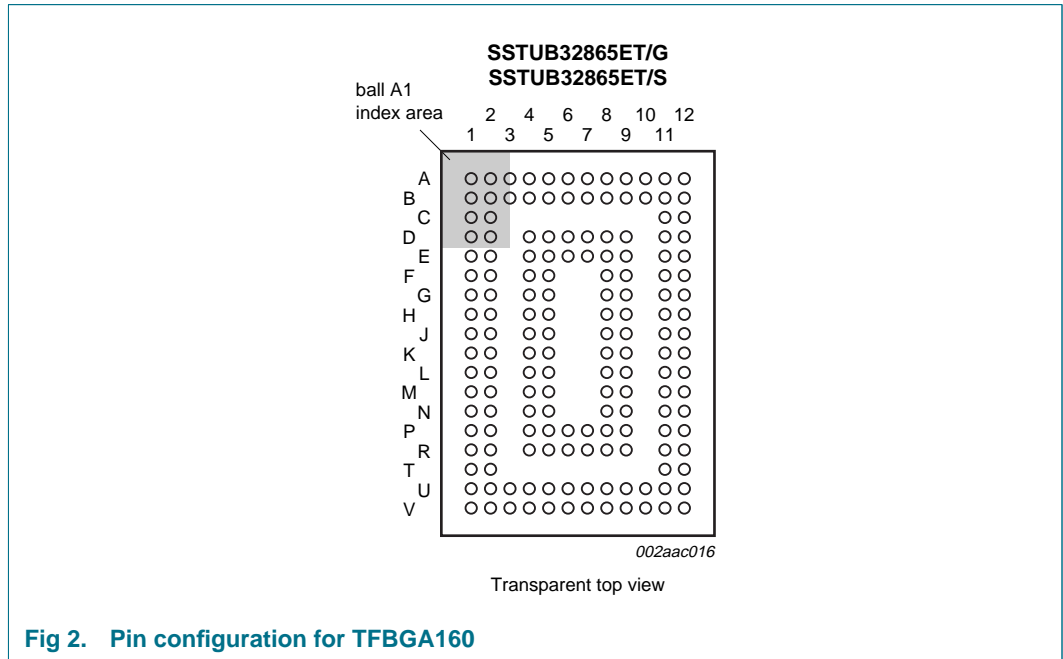

Fig 1. Functional diagram of SSTUB32865

6. Pinning information

6.1 Pinning



	1	2	3	4	5	6	7	8	9	10	11	12
A	VREF	SELDR	PARIN	n.c.	n.c.	QCKE1A	QCKE0A	Q21A	Q19A	Q18A	Q17B	Q17A
B	D1	D2	n.c.	n.c.	n.c.	QCKE1B	QCKE0B	Q21B	Q19B	Q18B	QODT0B	QODT0A
C	D3	D4									QODT1B	QODT1A
D	D6	D5		VDDL	GND	n.c.	n.c.	GND	GND		Q20B	Q20A
E	D7	D8		VDDL	GND	VDDL	VDDR	GND	GND		Q16B	Q16A
F	D11	D9		VDDL	GND			VDDR	VDDR		Q1B	Q1A
G	D18	D12		VDDL	GND			VDDR	VDDR		Q2B	Q2A
H	CSGATEEN	D15		$\overline{\text{DCS2}}$	GND			GND	GND		Q5B	Q5A
J	CK	$\overline{\text{DCS0}}$		GND	GND			VDDR	VDDR		$\overline{\text{QCS0B}}$	$\overline{\text{QCS0A}}$
K	$\overline{\text{CK}}$	$\overline{\text{DCS1}}$		$\overline{\text{DCS3}}$	VDDL			GND	GND		$\overline{\text{QCS1B}}$	$\overline{\text{QCS1A}}$
L	$\overline{\text{RESET}}$	D14		GND	GND			VDDR	VDDR		Q6B	Q6A
M	D0	D10		GND	GND			GND	GND		Q10B	Q10A
N	D17	D16		VDDL	VDDL			VDDR	VDDR		Q9B	Q9A
P	D19	D21		GND	VDDL	VDDL	VDDR	VDDR	GND		Q11B	Q11A
R	D13	D20		GND	VDDL	VDDL	GND	GND	GND		Q15B	Q15A
T	DODT1	DODT0									Q14B	Q14A
U	DCKE0	DCKE1	MCL	$\overline{\text{PTYERR}}$	MCH	Q3B	Q12B	Q7B	Q4B	Q13B	Q0B	Q8B
V	VREF	MCL	MCL	n.c.	MCH	Q3A	Q12A	Q7A	Q4A	Q13A	Q0A	Q8A

002aac017

160-ball, 12 × 18 grid; top view.

An empty cell indicates no ball is populated at that grid point.

n.c. denotes a no-connect (ball present but not connected to the die).

MCL denotes a pin that must be connected LOW.

MCH denotes a pin that must be connected HIGH.

Fig 3. Ball mapping

6.2 Pin description

Table 3. Pin description

Symbol	Pin	Type	Description
Ungated inputs			
DCKE0, DCKE1	U1, U2	SSTL_18	DRAM function pins not associated with Chip Select.
DODT0, DODT1	T2, T1		
Chip Select gated inputs			
D0 to D21	M1, B1, B2, C1, C2, D2, D1, E1, E2, F2, M2, F1, G2, R1, L2, H2, N2, N1, G1, P1, R2, P2	SSTL_18	DRAM inputs, re-driven only when Chip Select is LOW.
Chip Select inputs			
$\overline{DCS0}$, $\overline{DCS1}$, $\overline{DCS2}$, $\overline{DCS3}$ [U]	J2, K2, H4, K4	SSTL_18	DRAM Chip Select signals. These pins initiate DRAM address/command decodes, and as such at least one will be LOW when a valid address/command is present. The register can be programmed to re-drive all D-inputs only (CSGATEEN = HIGH) when at least one Chip Select input is LOW. $\overline{DCS2}$ and $\overline{DCS3}$ are not re-driven and can be left open-circuit to default HIGH by means of its internal pull-up resistors.
Re-driven outputs			
Q0A to Q21A	V11, F12, G12, V6, V9, H12, L12, V8, V12, N12, M12, P12, V7, V10, T12, R12, E12, A12, A10, A9, D12, A8	SSTL_18	Outputs of the register, valid after the specified clock count and immediately following a rising edge of the clock.
Q0B to Q21B	U11, F11, G11, U6, U9, H11, L11, U8, U12, N11, M11, P11, U7, U10, T11, R11, E11, A11, B10, B9, D11, B8		
$\overline{QCS0A}$, $\overline{QDS1A}$, $\overline{QCS0B}$, $\overline{QCS1B}$	J12, K12, J11, K11		
QCKE0A, QCKE1A, QCKE0B, QCKE1B	A7, A6, B7, B6		
QODT0A, QODT1A, QODT0B, QODT1B	B12, C12, B11, C11		
Parity input			
PARIN	A3	SSTL_18	Parity input for the D0 to D21 inputs. Arrives one clock cycle after the corresponding data input.
Parity error			
\overline{PTYERR}	U4	open-drain	When LOW, this output indicates that a parity error was identified associated with the address and/or command inputs. \overline{PTYERR} will be active for two clock cycles, and delayed by an additional clock cycle for compatibility with final parity out timing on the industry-standard DDR2 register with parity (in JEDEC definition).

Table 3. Pin description ...continued

Symbol	Pin	Type	Description
Program inputs			
CSGATEEN	H1	1.8 V LVC MOS with weak pull-up	Chip Select Gate Enable. When HIGH, the D0 to D21 inputs will be latched only when at least one Chip Select input is LOW during the rising edge of the clock. When LOW, the D0 to D21 inputs will be latched and redriven on every rising edge of the clock.
SELDR	A2	LVC MOS input	Selects output drive strength: 'HIGH' for normal drive, 'LOW' for high drive. This pin will default HIGH if left open-circuit (built-in weak pull-up resistor).
Clock inputs			
CK, $\overline{\text{CK}}$	J1, K1	SSTL_18	Differential master clock input pair to the register. The register operation is triggered by a rising edge on the positive clock input (CK).
Miscellaneous inputs			
MCL	U3, V2, V3		Must be connected to a logic LOW.
MCH	U5, V5		Must be connected to a logic HIGH.
$\overline{\text{RESET}}$	L1	1.8 V LVC MOS with weak pull-up	Asynchronous reset input. When LOW, it causes a reset of the internal latches, thereby forcing the outputs LOW. RESET also resets the PTYERR signal.
VREF	A1, V1	0.9 V nominal	Input reference voltage for the SSTL_18 inputs. Two pins (internally tied together) are used for increased reliability.
VDDL	D4, E4, E6, F4, G4, K5, N4, N5, P5, P6, R5, R6		Power supply voltage.
VDDR	E7, F8, F9, G8, G9, J8, J9, L8, L9, N8, N9, P7, P8		Power supply voltage.
GND	D5, D8, D9, E5, E8, E9, F5, G5, H5, H8, H9, J4, J5, K8, K9, L4, L5, M4, M5, M8, M9, P4, P9, R4, R7, R8, R9		Ground.
n.c.	A4, A5, B3, B4, B5, D6, D7, V4		Ball present but not connected to die.

[1] If application does not require $\overline{\text{DCS2}}$ and $\overline{\text{DCS3}}$, it is allowed to connect H4 and K4 to V_{DD} .

7. Functional description

7.1 Function table

Table 4. Function table (each flip-flop)

Inputs							Outputs ^[1]			
RESET	DCS0 ^[2]	DCS1 ^[2]	CSGATEEN	CK	\overline{CK}	Dn, DODTn, DCKEn	Qn	$\overline{QCS0}$	$\overline{QCS1}$	QODTn, QCKEn
H	L	L	X	↑	↓	L	L	L	L	L
H	L	L	X	↑	↓	H	H	L	L	H
H	L	L	X	L or H	L or H	X	Q ₀	Q ₀	Q ₀	Q ₀
H	L	H	X	↑	↓	L	L	L	H	L
H	L	H	X	↑	↓	H	H	L	H	H
H	L	H	X	L or H	L or H	X	Q ₀	Q ₀	Q ₀	Q ₀
H	H	L	X	↑	↓	L	L	H	L	L
H	H	L	X	↑	↓	H	H	H	L	H
H	H	L	X	L or H	L or H	X	Q ₀	Q ₀	Q ₀	Q ₀
H	H	H	L	↑	↓	L	L	H	H	L
H	H	H	L	↑	↓	H	H	H	H	H
H	H	H	L	L or H	L or H	X	Q ₀	Q ₀	Q ₀	Q ₀
H	H	H	H	↑	↓	L	Q ₀	H	H	L
H	H	H	H	↑	↓	H	Q ₀	H	H	H
H	H	H	H	L or H	L or H	X	Q ₀	Q ₀	Q ₀	Q ₀
L	X or floating	X or floating	X or floating	X or floating	X or floating	X or floating	L	L	L	L

[1] Q₀ is the previous state of the associated output.

[2] $\overline{DCS2}$ and $\overline{DCS3}$ operate identically to $\overline{DCS0}$ and $\overline{DCS1}$, except they do not have corresponding re-driven (QCS) outputs.

Table 5. Parity and standby function table

Inputs							Output	
RESET	DCS0 ^[1]	DCS1 ^[1]	CK	\overline{CK}	\sum of inputs = H (D0 to D21)	PARIN ^[2]	PTYERR ^{[3][4]}	
H	L	H	↑	↓	even	L	H	
H	L	H	↑	↓	odd	L	L	
H	L	H	↑	↓	even	H	L	
H	L	H	↑	↓	odd	H	H	
H	H	L	↑	↓	even	L	H	
H	H	L	↑	↓	odd	L	L	
H	H	L	↑	↓	even	H	L	
H	H	L	↑	↓	odd	H	H	
H	H	H	↑	↓	X	X	$\overline{PTYERR_0}$	
H	X	X	L or H	L or H	X	X	$\overline{PTYERR_0}$	
L	X or floating	X or floating	X or floating	X or floating	X or floating	X or floating	H	

- [1] $\overline{DCS2}$ and $\overline{DCS3}$ operate identically to $\overline{DCS0}$ and $\overline{DCS1}$ with regard to the parity function.
- [2] PARIN arrives one clock cycle after the data to which it applies. All Dn inputs must be driven to a known state for parity to be calculated correctly.
- [3] This condition assumes \overline{PTYERR} is HIGH at the crossing of CK going HIGH and \overline{CK} going LOW. If \overline{PTYERR} is LOW, it stays latched LOW for two clock cycles or until \overline{RESET} is driven LOW. CSGATEEN is 'don't care' for \overline{PTYERR} .
- [4] \overline{PTYERR}_0 is the previous state of output \overline{PTYERR} .

Table 6. Truth table SELDR

Input	Mode
SELDLDR	
L	high output drive
H	normal output drive

7.2 Functional information

This 28-bit 1 : 2 registered buffer with parity is designed for 1.7 V to 2.0 V V_{DD} operation.

All clock and data inputs are compatible with the JEDEC standard for SSTL_18. The control inputs are LVCMOS. All outputs are 1.8 V CMOS drivers that have been optimized to drive the DDR2 DIMM load.

The SSTUB32865 operates from a differential clock (CK and \overline{CK}). Data are registered at the crossing of CK going HIGH, and \overline{CK} going LOW.

A programming pin, SELDR, allows the user to select between two drive strength options by tying this pin either LOW or HIGH on the DIMM. The truth table for these options is shown in [Table 6](#).

The device supports low-power standby operation. When the reset input (\overline{RESET}) is LOW, the differential input receivers are disabled, and undriven (floating) data, clock and reference voltage (VREF) inputs are allowed. In addition, when \overline{RESET} is LOW all registers are reset, and all outputs except \overline{PTYERR} are forced LOW. The LVCMOS \overline{RESET} input must always be held at a valid logic HIGH or LOW level.

To ensure defined outputs from the register before a stable clock has been supplied, \overline{RESET} must be held in the LOW state during power-up.

In the DDR2 RDIMM application, \overline{RESET} is specified to be completely asynchronous with respect to CK and \overline{CK} . Therefore, no timing relationship can be guaranteed between the two. When entering reset, the register will be cleared and the data outputs will be driven LOW quickly, relative to the time to disable the differential input receivers. However, when coming out of reset, the register will become active quickly, relative to the time to enable the differential input receivers. As long as the data inputs are LOW, and the clock is stable during the time from the LOW-to-HIGH transition of \overline{RESET} until the input receivers are fully enabled, the design of the SSTUB32865 ensures that the outputs remain LOW, thus ensuring no glitches on the output.

The device monitors $\overline{DCS0}$, $\overline{DCS1}$, $\overline{DCS2}$ and $\overline{DCS3}$ inputs and will gate the Qn outputs from changing states when all \overline{DCSn} inputs are HIGH. If \overline{DCSn} input is LOW, the Qn outputs will function normally. The \overline{RESET} input has priority over the \overline{DCSn} control and will force the Qn outputs LOW and the \overline{PTYERR} output HIGH. If the \overline{DCSn} -control

functionality is not desired, then the CSGATEEN input can be hardwired to ground, in which case, the set-up time requirement for \overline{DCSn} would be the same as for the other Dn data inputs.

The SSTUB32865 includes a parity checking function. The SSTUB32865 accepts a parity bit from the memory controller at its input pin PARIN, compares it with the data received on the Dn inputs (with either \overline{DCSn} inputs active) and indicates whether a parity error has occurred on its open-drain \overline{PTYERR} pin (active LOW).

7.3 Functional differences to SSTU32864

The SSTUB32865 for its basic register functionality, signal definition and performance is based upon the industry-standard SSTU32864, but provides key operational features which differ (at least in part) from the industry-standard register in the following aspects:

7.3.1 Chip Select (CS) gating of key inputs ($\overline{DCS0}$, $\overline{DCS1}$, $\overline{DCS2}$, $\overline{DCS3}$, CSGATEEN)

As a means to reduce device power, the internal latches will only be updated when one or more of the CS inputs are active (LOW) and CSGATEEN HIGH at the rising edge of the clock. The 22 'Chip-Select-gated' input signals associated with this function include addresses (ADDR0 to ADDR15, BA0 to BA2), and RAS, CAS, WE, with the remaining signals (CS, CKE, ODT) continuously re-driven at the rising edge of every clock as they are independent of CS. The CS gating function can be disabled by tying CSGATEEN LOW, enabling all internal latches to be updated on every rising edge of the clock.

Table 7. Chip Select gating mode

Mode	Signal name	Description
Gating	CSGATEEN HIGH	Registers only re-drive signals to the DRAMs when Chip Select inputs are LOW.
Non-gating	CSGATEEN LOW	Registers always re-drive signals on every clock cycle, independent of the state of the Chip Select inputs.

7.3.2 Parity error checking and reporting

The SSTUB32865 incorporates a parity function, whereby the signal received on input pin PARIN is received as parity to the register, one clock cycle later than the CS-gated inputs. The received parity bit is then compared to the parity calculated across these same inputs by the register parity logic to verify that the information has not been corrupted. The 22 CS-gated input signals will be latched and re-driven on the first clock, and any error will be reported one clock cycle later via the \overline{PTYERR} output pin (driven LOW for two consecutive clock cycles). \overline{PTYERR} is an open-drain output, allowing multiple modules to share a common signal pin for reporting the occurrence of a parity error during a valid command cycle (coincident with the re-driven signals). This output is driven LOW for two consecutive clock cycles to allow the memory controller sufficient time to sense and capture the error even. A LOW state on \overline{PTYERR} indicates that a parity error has occurred.

7.3.3 Reset (\overline{RESET})

Similar to the \overline{RESET} pin on the industry-standard SSTU32864, this pin is used to clear all internal latches and all outputs will be driven LOW quickly except the \overline{PTYERR} output, which will be floated (and will normally default HIGH by their external pull-up).

7.3.4 Power-up sequence

The reset function for the SSTUB32865 is similar to that of the SSTU32864 except that the $\overline{\text{PTYERR}}$ signal is also cleared and will be held clear (HIGH) for three consecutive clock cycles.

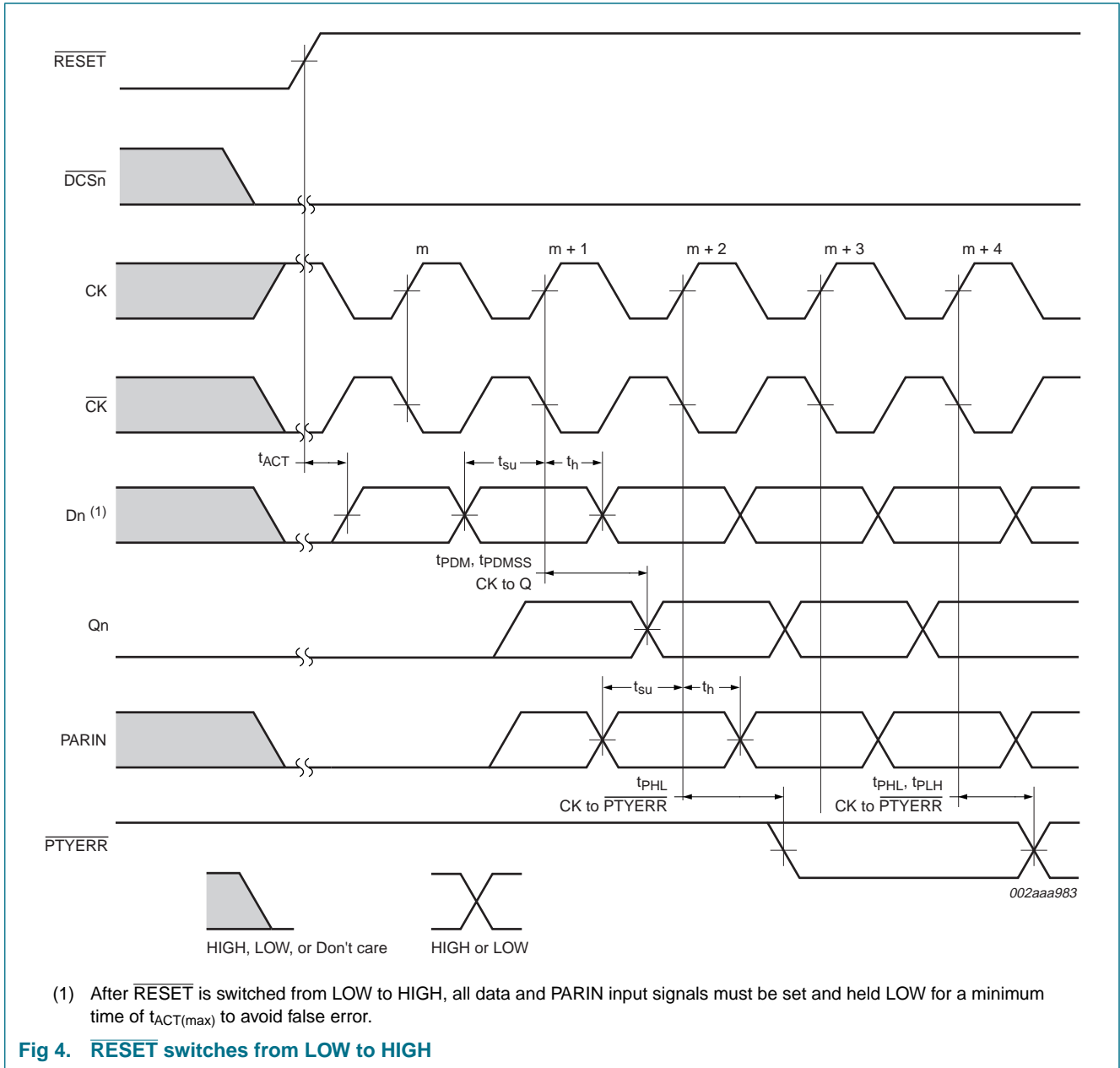

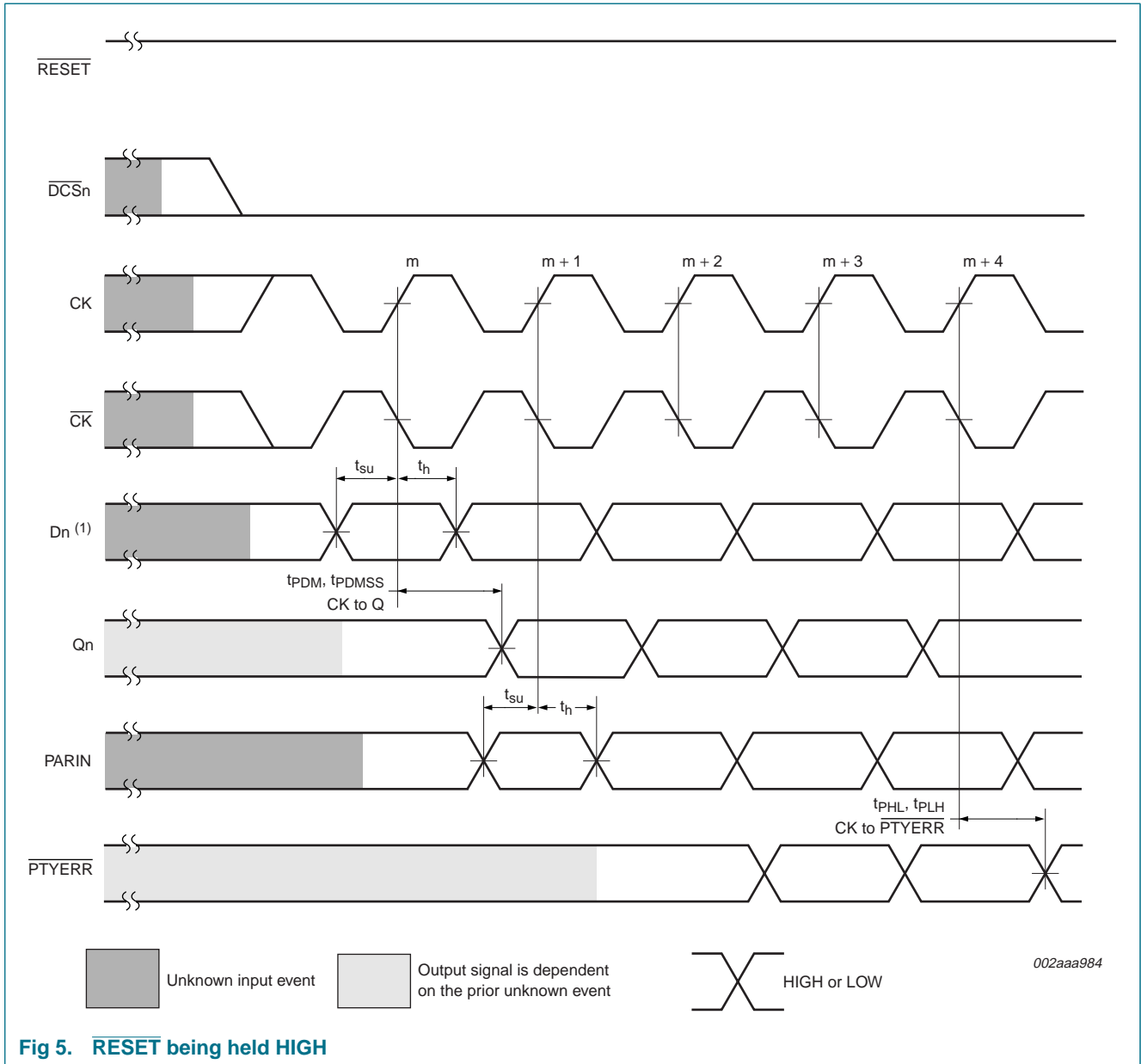
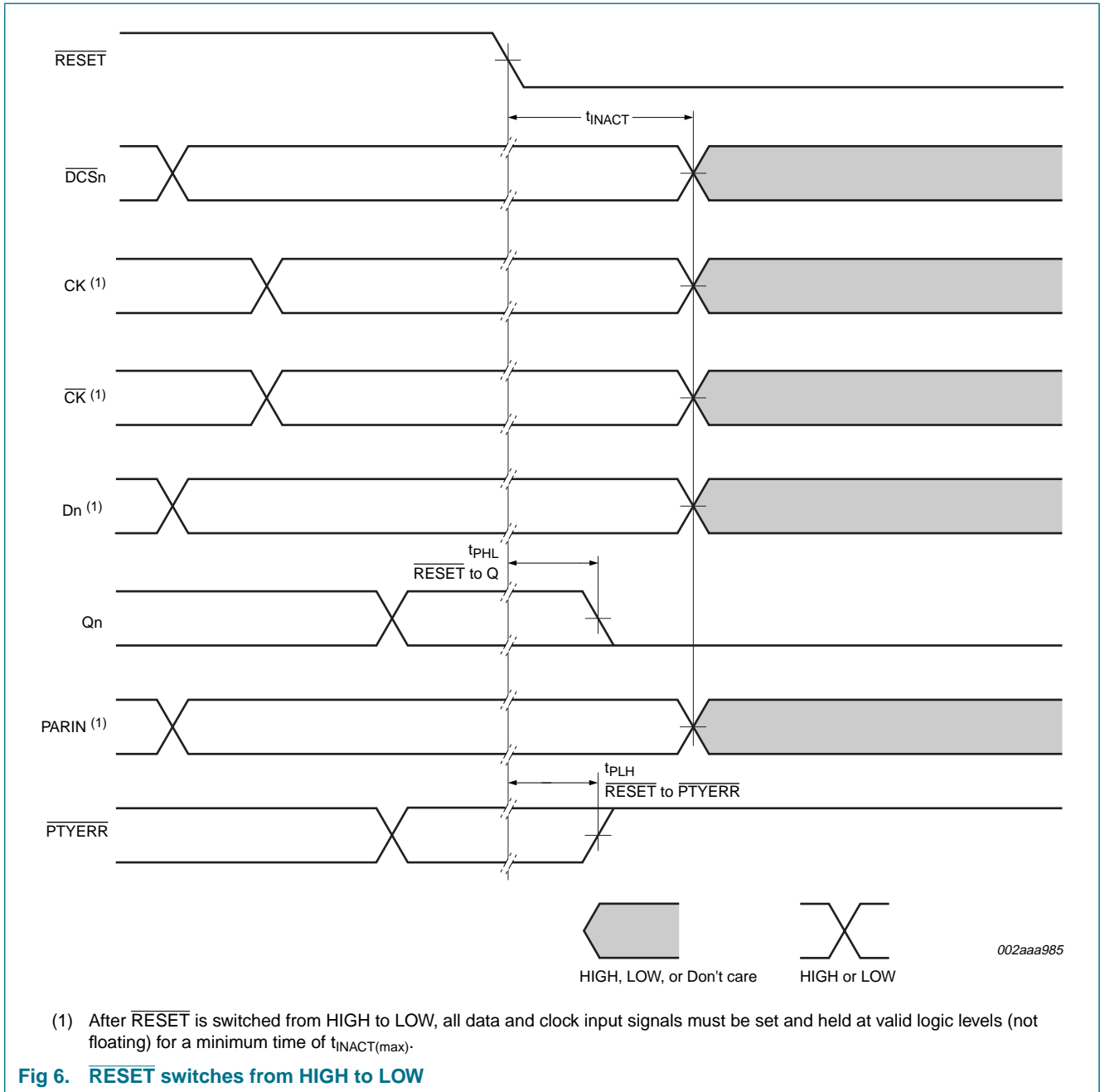
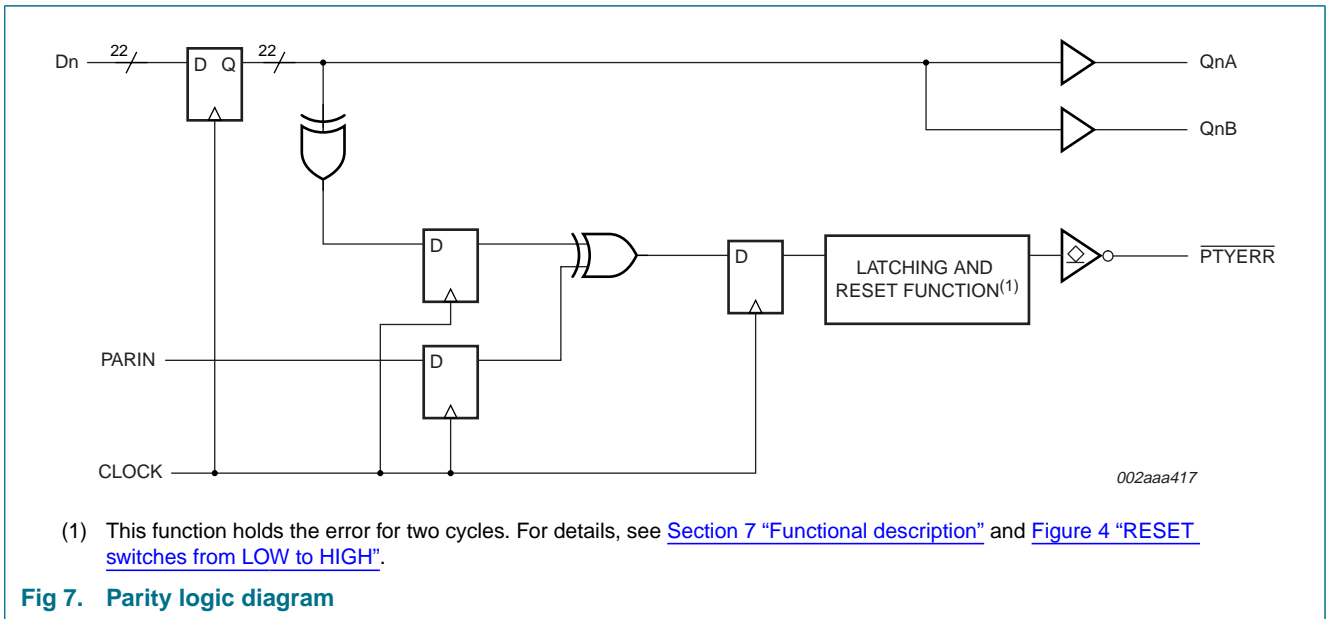

Fig 5. RESET being held HIGH





8. Limiting values

Table 8. Limiting values

In accordance with the Absolute Maximum Rating System (IEC 60134).

Symbol	Parameter	Conditions	Min	Max	Unit
V _{DD}	supply voltage		-0.5	+2.5	V
V _I	input voltage	receiver	[1] -0.5	+2.5	V
V _O	output voltage	driver	[1] -0.5	V _{DD} + 0.5	V
I _{IK}	input clamping current	V _I < 0 V or V _I > V _{DD}	-	-50	mA
I _{OK}	output clamping current	V _O < 0 V or V _O > V _{DD}	-	±50	mA
I _O	output current	continuous; 0 V < V _O < V _{DD}	-	±50	mA
I _{CCC}	continuous current through each V _{DD} or GND pin		-	±100	mA
T _{stg}	storage temperature		-65	+150	°C
V _{esd}	electrostatic discharge voltage	Human Body Model (HBM); 1.5 kΩ; 100 pF	2	-	kV
		Machine Model (MM); 0 Ω; 200 pF	200	-	V

[1] The input and output negative-voltage ratings may be exceeded if the input and output current ratings are observed.

9. Recommended operating conditions

Table 9. Recommended operating conditions

Symbol	Parameter	Conditions	Min	Typ	Max	Unit
V _{DD}	supply voltage		1.7	-	2.0	V
V _{ref}	reference voltage		0.49 × V _{DD}	0.50 × V _{DD}	0.51 × V _{DD}	V
V _{TT}	termination voltage		V _{ref} - 0.040	V _{ref}	V _{ref} + 0.040	V
V _I	input voltage		0	-	V _{DD}	V
V _{IH(AC)}	AC HIGH-level input voltage	data inputs (Dn)	[1] V _{ref} + 0.250	-	-	V
V _{IL(AC)}	AC LOW-level input voltage	data inputs (Dn)	[1] -	-	V _{ref} - 0.250	V
V _{IH(DC)}	DC HIGH-level input voltage	data inputs (Dn)	[1] V _{ref} + 0.125	-	-	V
V _{IL(DC)}	DC LOW-level input voltage	data inputs (Dn)	[1] -	-	V _{ref} - 0.125	V
V _{IH}	HIGH-level input voltage	$\overline{\text{RESET}}$	[2] 0.65 × V _{DD}	-	-	V
V _{IL}	LOW-level input voltage	$\overline{\text{RESET}}$	[2] -	-	0.35 × V _{DD}	V
V _{ICR}	common mode input voltage range	CK, $\overline{\text{CK}}$	0.675	-	1.125	V
V _{ID}	differential input voltage	CK, $\overline{\text{CK}}$	600	-	-	mV
I _{OH}	HIGH-level output current	SELDR either HIGH or LOW	-	-	-8	mA
I _{OL}	LOW-level output current	SELDR either HIGH or LOW	-	-	8	mA
T _{amb}	ambient temperature	operating in free air				
		SSTUB32865ET/G	0	-	+70	°C
		SSTUB32865ET/S	0	-	+85	°C

[1] The differential inputs must not be floating, unless $\overline{\text{RESET}}$ is LOW.

[2] The $\overline{\text{RESET}}$ input of the device must be held at valid logic levels (not floating) to ensure proper device operation.

10. Characteristics

Table 10. Characteristics

Over recommended operating conditions, unless otherwise noted.

Symbol	Parameter	Conditions	Min	Typ	Max	Unit
V_{OH}	HIGH-level output voltage	$I_{OH} = -6 \text{ mA}$; $V_{DD} = 1.7 \text{ V}$	1.2	-	-	V
V_{OL}	LOW-level output voltage	$I_{OL} = 6 \text{ mA}$; $V_{DD} = 1.7 \text{ V}$	-	-	0.5	V
I_I	input current	all inputs; $V_I = V_{DD}$ or GND; $V_{DD} = 2.0 \text{ V}$	-	-	± 5	μA
I_{DD}	supply current	static standby current; $\overline{\text{RESET}} = \text{GND}$; $V_{DD} = 2.0 \text{ V}$	-	-	2	mA
		static operating current; $\overline{\text{RESET}} = V_{DD}$; $V_{DD} = 2.0 \text{ V}$; $V_I = V_{IH(AC)}$ or $V_{IL(AC)}$	-	-	40	mA
I_{DD}	dynamic operating current per MHz	clock only; $\overline{\text{RESET}} = V_{DD}$; $V_I = V_{IH(AC)}$ or $V_{IL(AC)}$; CK and $\overline{\text{CK}}$ switching at 50 % duty cycle. $I_O = 0 \text{ mA}$; $V_{DD} = 1.8 \text{ V}$	-	16	-	μA
		per each data input; $\overline{\text{RESET}} = V_{DD}$; $V_I = V_{IH(AC)}$ or $V_{IL(AC)}$; CK and $\overline{\text{CK}}$ switching at 50 % duty cycle. One data input switching at half clock frequency, 50 % duty cycle. $I_O = 0 \text{ mA}$; $V_{DD} = 1.8 \text{ V}$	-	19	-	μA
C_i	input capacitance	data inputs; $V_I = V_{ref} \pm 250 \text{ mV}$; $V_{DD} = 1.8 \text{ V}$	2.5	-	3.5	pF
		CK and $\overline{\text{CK}}$; $V_{ICR} = 0.9 \text{ V}$; $V_{ID} = 600 \text{ mV}$; $V_{DD} = 1.8 \text{ V}$	2	-	3	pF
		$\overline{\text{RESET}}$; $V_I = V_{DD}$ or GND; $V_{DD} = 1.8 \text{ V}$	3	-	5	pF
Z_o	output impedance	normal drive; instantaneous	[1]	15	-	Ω
		normal drive; steady-state	-	53	-	Ω
		high drive; instantaneous	[1]	7	-	Ω
		high drive; steady-state	-	53	-	Ω

[1] Instantaneous is defined as within < 2 ns following the output data transition edge.

Table 11. Timing requirements

Over recommended operating conditions, unless otherwise noted.

Symbol	Parameter	Conditions	Min	Typ	Max	Unit
f_{clock}	clock frequency		-	-	450	MHz
t_{W}	pulse width	CK, $\overline{\text{CK}}$ HIGH or LOW	1	-	-	ns
t_{ACT}	differential inputs active time		[1][2]	-	10	ns
t_{INACT}	differential inputs inactive time		[1][3]	-	15	ns
t_{su}	set-up time	Chip Select; $\overline{\text{DCS0}}$, $\overline{\text{DCS1}}$ valid before clock switching	0.6	-	-	ns
		Data; Dn valid before clock switching	0.5	-	-	ns
		PARIN; PARIN before CK and $\overline{\text{CK}}$	0.5	-	-	ns
t_{h}	hold time	input to remain valid after clock switching	0.4	-	-	ns
		PARIN after CK and $\overline{\text{CK}}$	0.4	-	-	ns

[1] This parameter is not necessarily production tested.

[2] Data inputs must be active below a minimum time of $t_{\text{ACT(max)}}$ after $\overline{\text{RESET}}$ is taken HIGH.

[3] Data and clock inputs must be held at valid levels (not floating) a minimum time of $t_{\text{INACT(max)}}$ after $\overline{\text{RESET}}$ is taken LOW.

Table 12. Switching characteristics

Over recommended operating conditions, unless otherwise noted.

Symbol	Parameter	Conditions	Min	Typ	Max	Unit	
f_{max}	maximum input clock frequency		450	-	-	MHz	
t_{PDM}	peak propagation delay	CK and $\overline{\text{CK}}$ to output	[1]	1.1	-	1.5	ns
t_{LH}	LOW to HIGH delay time	CK and $\overline{\text{CK}}$ to $\overline{\text{PTYERR}}$	1.2	-	3	ns	
t_{HL}	HIGH to LOW delay time	CK and $\overline{\text{CK}}$ to $\overline{\text{PTYERR}}$	1	-	3	ns	
t_{PLH}	LOW-to-HIGH propagation delay	from $\overline{\text{RESET}}$ to $\overline{\text{PTYERR}}$	-	-	3	ns	
t_{PDMSS}	simultaneous switching peak propagation delay	CK and $\overline{\text{CK}}$ to output	[1][2]	-	-	1.6	ns
t_{PHL}	HIGH-to-LOW propagation delay	$\overline{\text{RESET}}$ to output	-	-	3	ns	

[1] Includes 350 ps of test-load transmission line delay.

[2] This parameter is not necessarily production tested.

Table 13. Output edge rates

Over recommended operating conditions, unless otherwise noted.

Symbol	Parameter	Conditions	Min	Typ	Max	Unit
dV/dt_{r}	rising edge slew rate		1	-	4	V/ns
dV/dt_{f}	falling edge slew rate		1	-	4	V/ns
dV/dt_{Δ}	absolute difference between dV/dt_{r} and dV/dt_{f}		-	-	1	V/ns

11. Test information

11.1 Test circuit

All input pulses are supplied by generators having the following characteristics: Pulse Repetition Rate (PRR) \leq 10 MHz; $Z_0 = 50 \Omega$; input slew rate = 1 V/ns \pm 20 %, unless otherwise specified.

The outputs are measured one at a time with one transition per measurement.

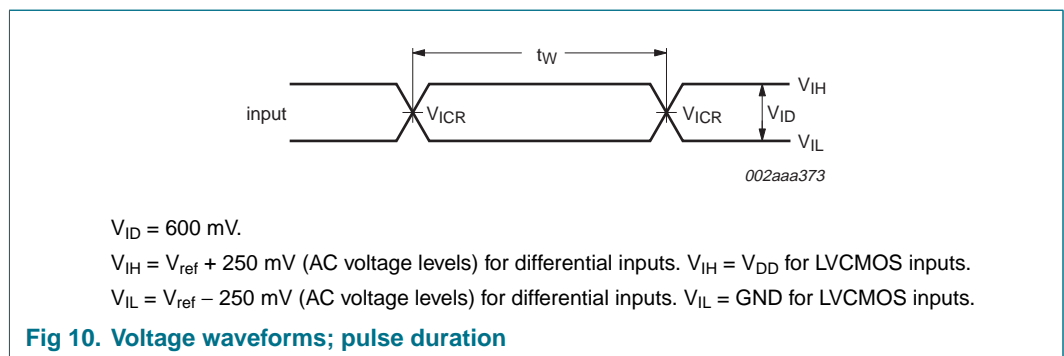
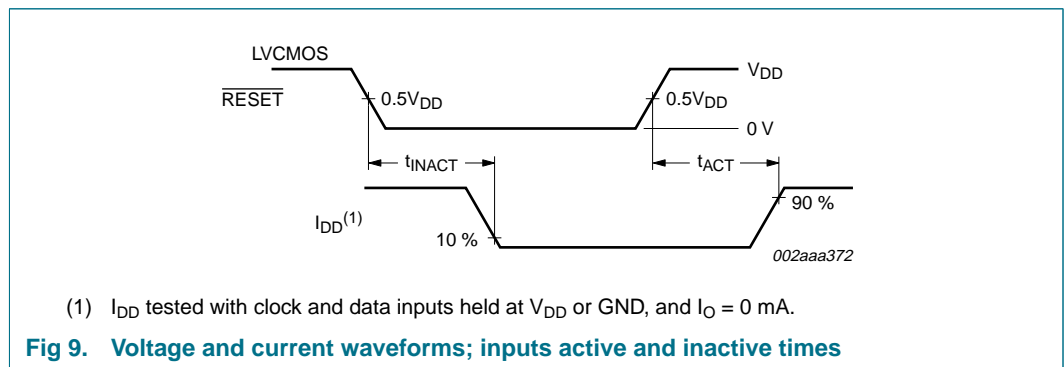
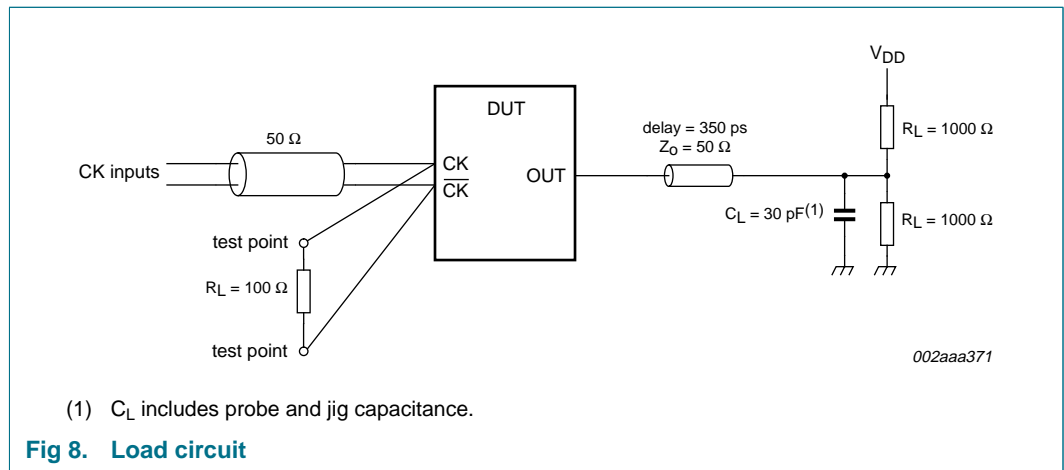

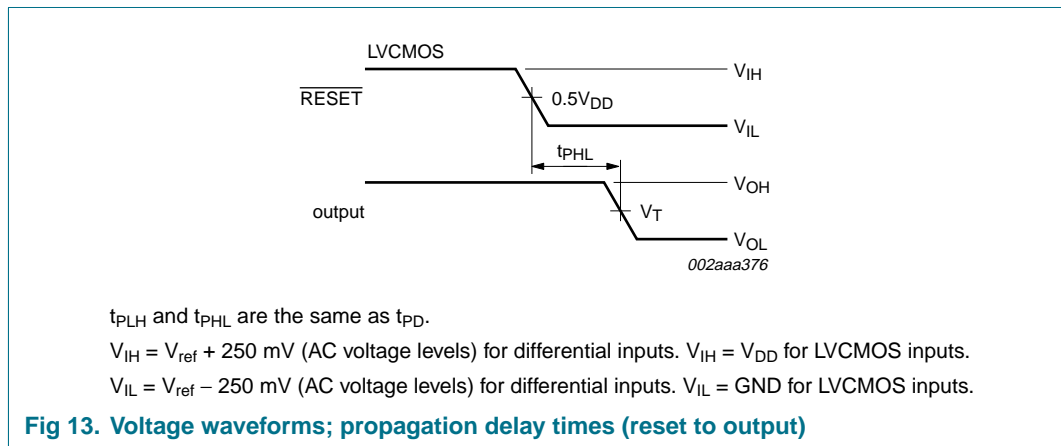
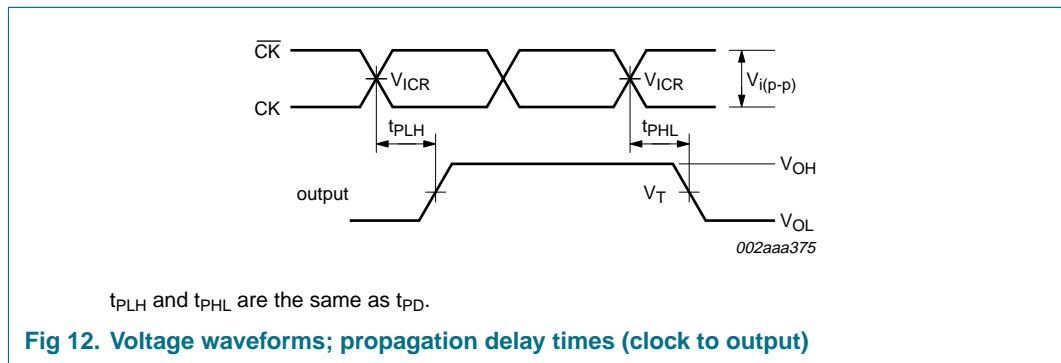
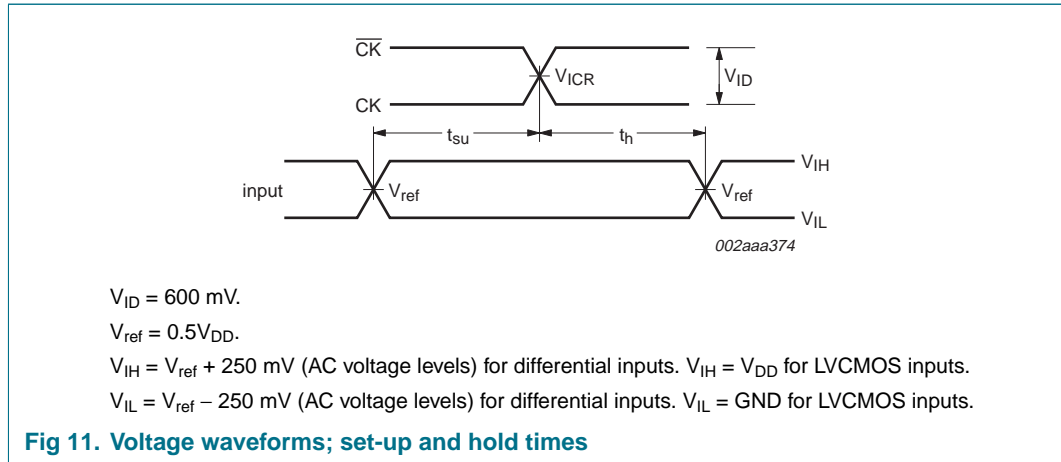

11.2 Output slew rate measurement

$V_{DD} = 1.8\text{ V} \pm 0.1\text{ V}$.

All input pulses are supplied by generators having the following characteristics:
 $PRR \leq 10\text{ MHz}$; $Z_o = 50\ \Omega$; input slew rate = $1\text{ V/ns} \pm 20\%$, unless otherwise specified.

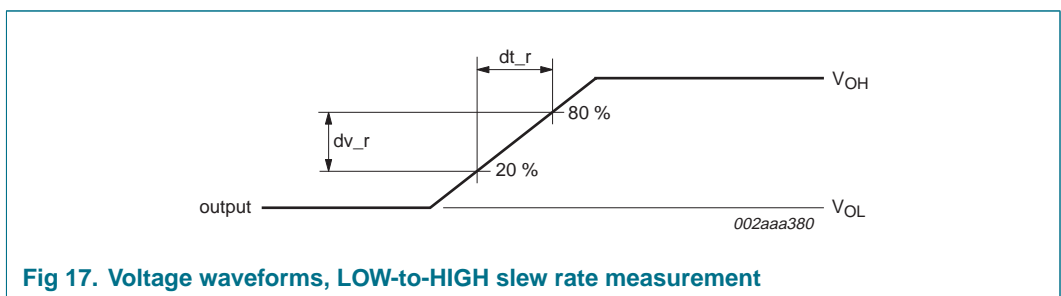
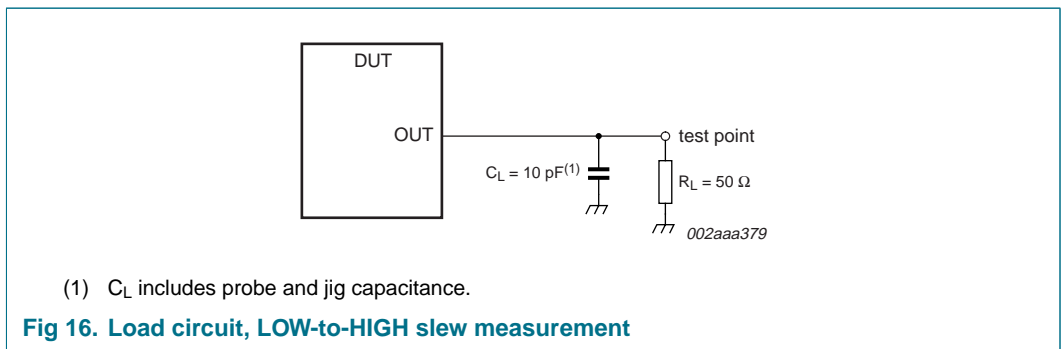
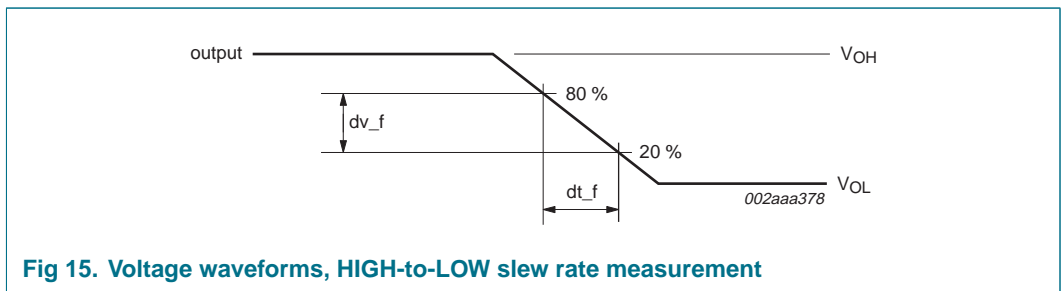
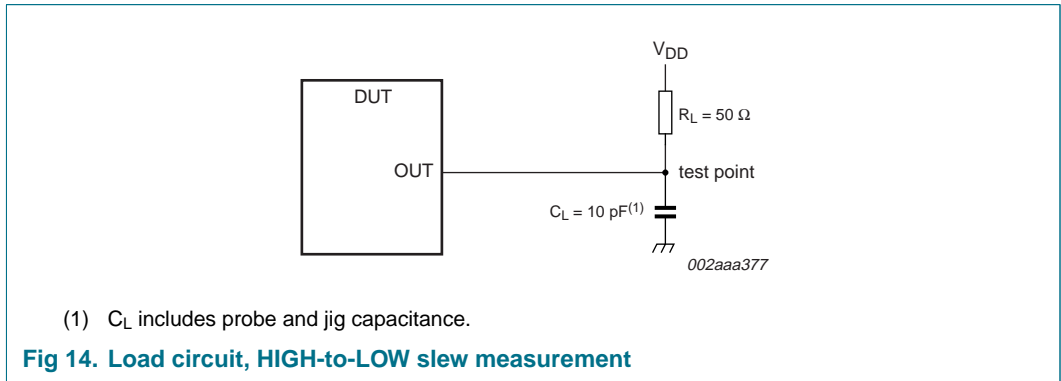

11.3 Error output load circuit and voltage measurement

$V_{DD} = 1.8 V \pm 0.1 V$.

All input pulses are supplied by generators having the following characteristics: $PRR \leq 10 \text{ MHz}$; $Z_o = 50 \Omega$; input slew rate = $1 \text{ V/ns} \pm 20 \%$, unless otherwise specified.

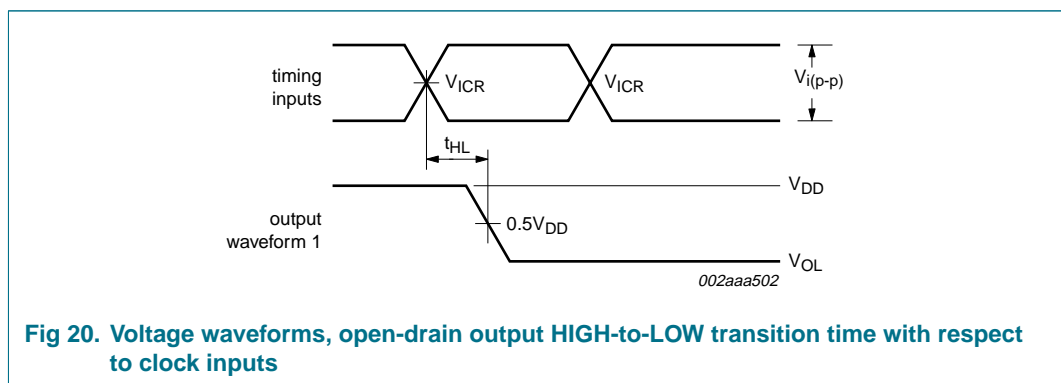
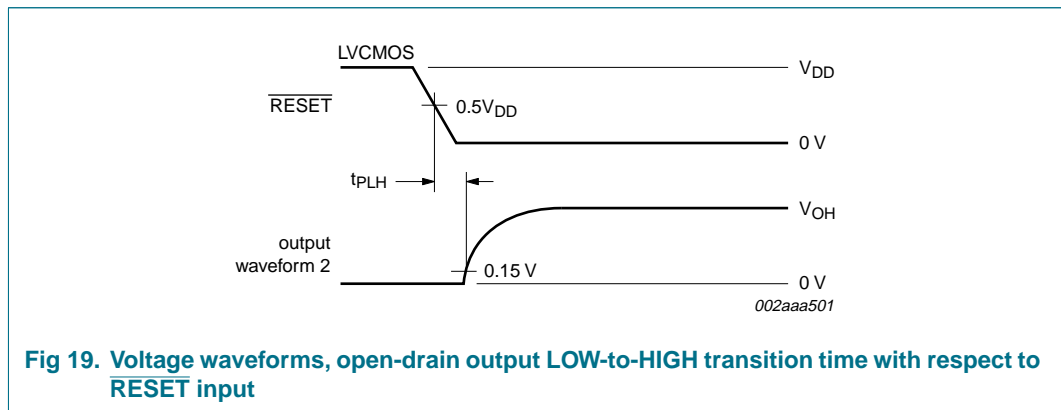
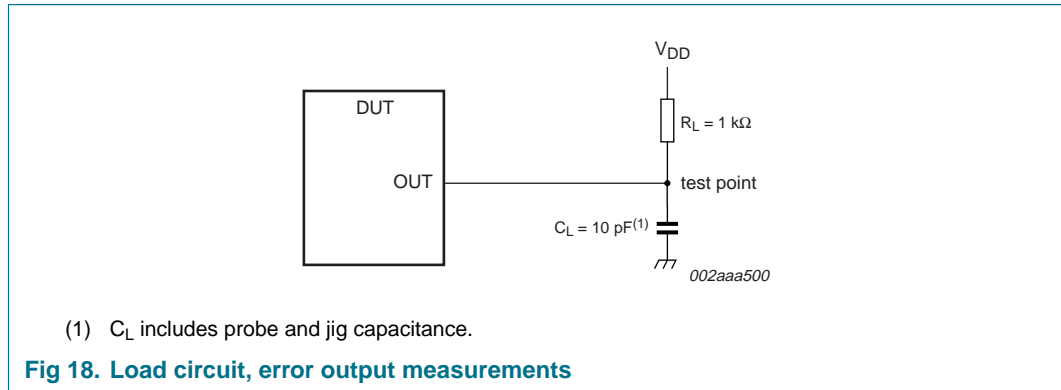

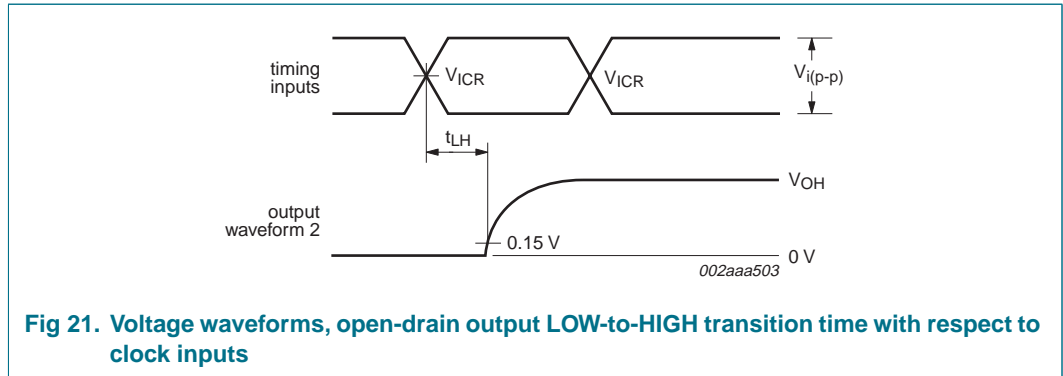

12. Package outline

TFBGA160: plastic thin fine-pitch ball grid array package; 160 balls; body 9 x 13 x 0.7 mm

SOT802-2

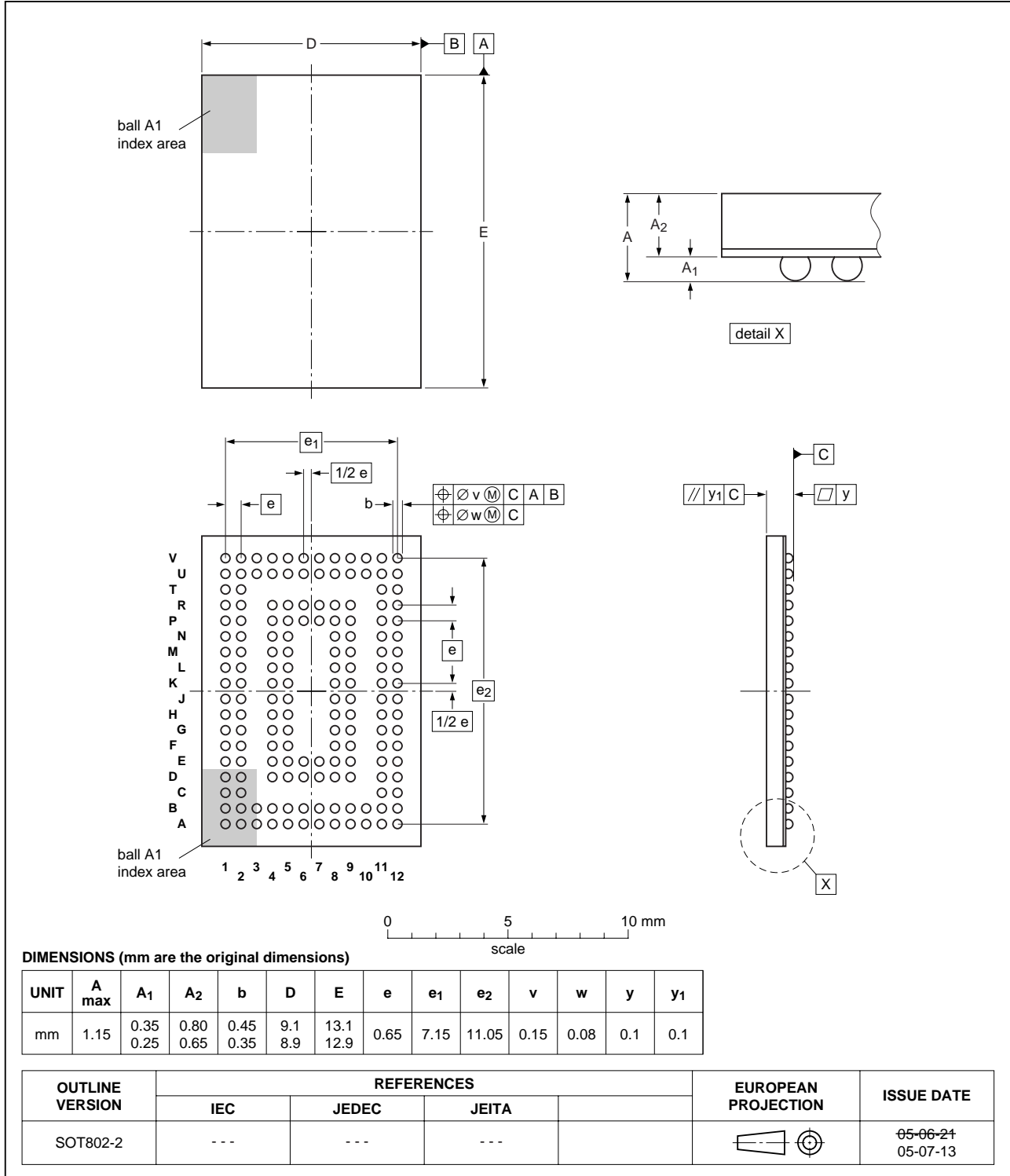

Fig 22. Package outline SOT802-2 (TFBGA160)

13. Soldering

This text provides a very brief insight into a complex technology. A more in-depth account of soldering ICs can be found in Application Note *AN10365 "Surface mount reflow soldering description"*.

13.1 Introduction to soldering

Soldering is one of the most common methods through which packages are attached to Printed Circuit Boards (PCBs), to form electrical circuits. The soldered joint provides both the mechanical and the electrical connection. There is no single soldering method that is ideal for all IC packages. Wave soldering is often preferred when through-hole and Surface Mount Devices (SMDs) are mixed on one printed wiring board; however, it is not suitable for fine pitch SMDs. Reflow soldering is ideal for the small pitches and high densities that come with increased miniaturization.

13.2 Wave and reflow soldering

Wave soldering is a joining technology in which the joints are made by solder coming from a standing wave of liquid solder. The wave soldering process is suitable for the following:

- Through-hole components
- Leaded or leadless SMDs, which are glued to the surface of the printed circuit board

Not all SMDs can be wave soldered. Packages with solder balls, and some leadless packages which have solder lands underneath the body, cannot be wave soldered. Also, leaded SMDs with leads having a pitch smaller than ~0.6 mm cannot be wave soldered, due to an increased probability of bridging.

The reflow soldering process involves applying solder paste to a board, followed by component placement and exposure to a temperature profile. Leaded packages, packages with solder balls, and leadless packages are all reflow solderable.

Key characteristics in both wave and reflow soldering are:

- Board specifications, including the board finish, solder masks and vias
- Package footprints, including solder thieves and orientation
- The moisture sensitivity level of the packages
- Package placement
- Inspection and repair
- Lead-free soldering versus PbSn soldering

13.3 Wave soldering

Key characteristics in wave soldering are:

- Process issues, such as application of adhesive and flux, clinching of leads, board transport, the solder wave parameters, and the time during which components are exposed to the wave
- Solder bath specifications, including temperature and impurities

13.4 Reflow soldering

Key characteristics in reflow soldering are:

- Lead-free versus SnPb soldering; note that a lead-free reflow process usually leads to higher minimum peak temperatures (see [Figure 23](#)) than a PbSn process, thus reducing the process window
- Solder paste printing issues including smearing, release, and adjusting the process window for a mix of large and small components on one board
- Reflow temperature profile; this profile includes preheat, reflow (in which the board is heated to the peak temperature) and cooling down. It is imperative that the peak temperature is high enough for the solder to make reliable solder joints (a solder paste characteristic). In addition, the peak temperature must be low enough that the packages and/or boards are not damaged. The peak temperature of the package depends on package thickness and volume and is classified in accordance with [Table 14](#) and [15](#)

Table 14. SnPb eutectic process (from J-STD-020C)

Package thickness (mm)	Package reflow temperature (°C)	
	Volume (mm ³)	
	< 350	≥ 350
< 2.5	235	220
≥ 2.5	220	220

Table 15. Lead-free process (from J-STD-020C)

Package thickness (mm)	Package reflow temperature (°C)		
	Volume (mm ³)		
	< 350	350 to 2000	> 2000
< 1.6	260	260	260
1.6 to 2.5	260	250	245
> 2.5	250	245	245

Moisture sensitivity precautions, as indicated on the packing, must be respected at all times.

Studies have shown that small packages reach higher temperatures during reflow soldering, see [Figure 23](#).

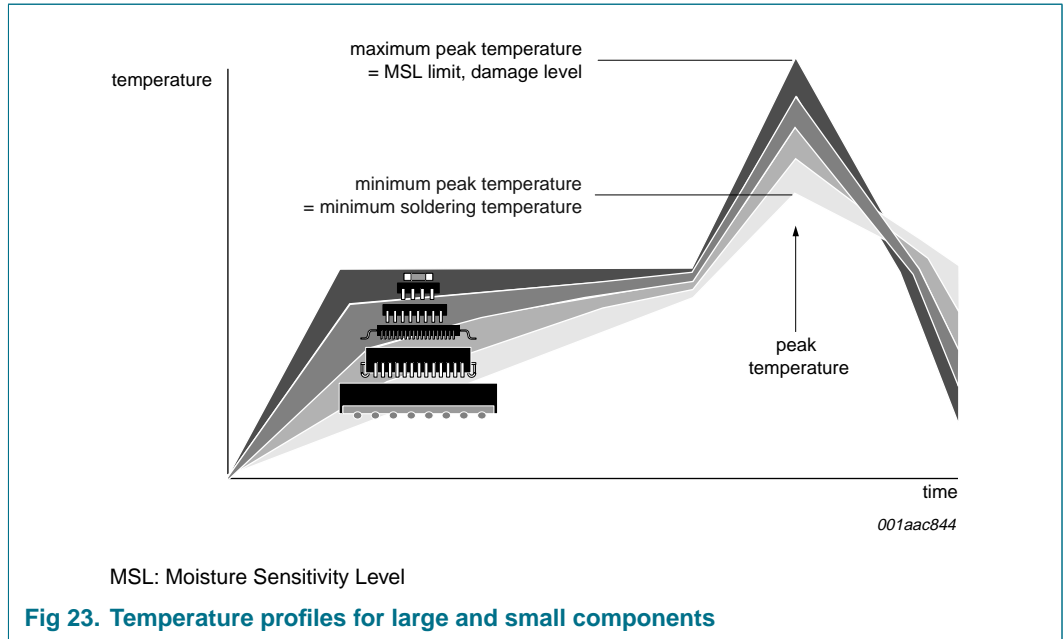

For further information on temperature profiles, refer to Application Note AN10365 “Surface mount reflow soldering description”.

14. Abbreviations

Table 16. Abbreviations

Acronym	Description
CMOS	Complementary Metal Oxide Semiconductor
DDR2	Double Data Rate 2
DIMM	Dual In-line Memory Module
DRAM	Dynamic Random Access Memory
LVCMOS	Low Voltage Complementary Metal Oxide Semiconductor
RDIMM	Registered Dual In-line Memory Module
SSTL	Stub Series Terminated Logic

15. Revision history

Table 17. Revision history

Document ID	Release date	Data sheet status	Change notice	Supersedes
SSTUB32865_3	20070327	Product data sheet	-	SSTUB32865_2
Modifications:	<ul style="list-style-type: none"> The format of this data sheet has been redesigned to comply with the new identity guidelines of NXP Semiconductors. Legal texts have been adapted to the new company name where appropriate. Table 10 “Characteristics”, I_{DD} (max) for static standby current changed from “100 μA” to “2 mA” 			
SSTUB32865_2	20060922	Product data sheet	-	SSTUB32865_1
SSTUB32865_1	20060807	Product data sheet	-	-

16. Legal information

16.1 Data sheet status

Document status ^{[1][2]}	Product status ^[3]	Definition
Objective [short] data sheet	Development	This document contains data from the objective specification for product development.
Preliminary [short] data sheet	Qualification	This document contains data from the preliminary specification.
Product [short] data sheet	Production	This document contains the product specification.

[1] Please consult the most recently issued document before initiating or completing a design.

[2] The term 'short data sheet' is explained in section "Definitions".

[3] The product status of device(s) described in this document may have changed since this document was published and may differ in case of multiple devices. The latest product status information is available on the Internet at URL <http://www.nxp.com>.

16.2 Definitions

Draft — The document is a draft version only. The content is still under internal review and subject to formal approval, which may result in modifications or additions. NXP Semiconductors does not give any representations or warranties as to the accuracy or completeness of information included herein and shall have no liability for the consequences of use of such information.

Short data sheet — A short data sheet is an extract from a full data sheet with the same product type number(s) and title. A short data sheet is intended for quick reference only and should not be relied upon to contain detailed and full information. For detailed and full information see the relevant full data sheet, which is available on request via the local NXP Semiconductors sales office. In case of any inconsistency or conflict with the short data sheet, the full data sheet shall prevail.

16.3 Disclaimers

General — Information in this document is believed to be accurate and reliable. However, NXP Semiconductors does not give any representations or warranties, expressed or implied, as to the accuracy or completeness of such information and shall have no liability for the consequences of use of such information.

Right to make changes — NXP Semiconductors reserves the right to make changes to information published in this document, including without limitation specifications and product descriptions, at any time and without notice. This document supersedes and replaces all information supplied prior to the publication hereof.

Suitability for use — NXP Semiconductors products are not designed, authorized or warranted to be suitable for use in medical, military, aircraft, space or life support equipment, nor in applications where failure or

malfunction of a NXP Semiconductors product can reasonably be expected to result in personal injury, death or severe property or environmental damage. NXP Semiconductors accepts no liability for inclusion and/or use of NXP Semiconductors products in such equipment or applications and therefore such inclusion and/or use is at the customer's own risk.

Applications — Applications that are described herein for any of these products are for illustrative purposes only. NXP Semiconductors makes no representation or warranty that such applications will be suitable for the specified use without further testing or modification.

Limiting values — Stress above one or more limiting values (as defined in the Absolute Maximum Ratings System of IEC 60134) may cause permanent damage to the device. Limiting values are stress ratings only and operation of the device at these or any other conditions above those given in the Characteristics sections of this document is not implied. Exposure to limiting values for extended periods may affect device reliability.

Terms and conditions of sale — NXP Semiconductors products are sold subject to the general terms and conditions of commercial sale, as published at <http://www.nxp.com/profile/terms>, including those pertaining to warranty, intellectual property rights infringement and limitation of liability, unless explicitly otherwise agreed to in writing by NXP Semiconductors. In case of any inconsistency or conflict between information in this document and such terms and conditions, the latter will prevail.

No offer to sell or license — Nothing in this document may be interpreted or construed as an offer to sell products that is open for acceptance or the grant, conveyance or implication of any license under any copyrights, patents or other industrial or intellectual property rights.

16.4 Trademarks

Notice: All referenced brands, product names, service names and trademarks are the property of their respective owners.

17. Contact information

For additional information, please visit: <http://www.nxp.com>

For sales office addresses, send an email to: salesaddresses@nxp.com

18. Contents

1	General description	1
2	Features	1
3	Applications	2
4	Ordering information	2
4.1	Ordering options	2
5	Functional diagram	3
6	Pinning information	4
6.1	Pinning	4
6.2	Pin description	6
7	Functional description	8
7.1	Function table	8
7.2	Functional information	9
7.3	Functional differences to SSTU32864	10
7.3.1	Chip Select (CS) gating of key inputs ($\overline{\text{DCS0}}$, $\overline{\text{DCS1}}$, $\overline{\text{DCS2}}$, $\overline{\text{DCS3}}$, CSGATEEN) ..	10
7.3.2	Parity error checking and reporting	10
7.3.3	Reset ($\overline{\text{RESET}}$)	10
7.3.4	Power-up sequence	11
8	Limiting values	15
9	Recommended operating conditions	15
10	Characteristics	16
11	Test information	18
11.1	Test circuit	18
11.2	Output slew rate measurement	20
11.3	Error output load circuit and voltage measurement	21
12	Package outline	23
13	Soldering	24
13.1	Introduction to soldering	24
13.2	Wave and reflow soldering	24
13.3	Wave soldering	24
13.4	Reflow soldering	25
14	Abbreviations	26
15	Revision history	26
16	Legal information	27
16.1	Data sheet status	27
16.2	Definitions	27
16.3	Disclaimers	27
16.4	Trademarks	27
17	Contact information	27
18	Contents	28

Please be aware that important notices concerning this document and the product(s) described herein, have been included in section 'Legal information'.

founded by

PHILIPS

© NXP B.V. 2007.

All rights reserved.

For more information, please visit: <http://www.nxp.com>

For sales office addresses, please send an email to: salesaddresses@nxp.com

Date of release: 27 March 2007

Document identifier: SSTUB32865_3