

SC16C2550B

5 V, 3.3 V and 2.5 V dual UART, 5 Mbit/s (max.), with 16-byte FIFOs

Rev. 05 — 12 January 2009

Product data sheet

1. General description

The SC16C2550B is a two channel Universal Asynchronous Receiver and Transmitter (UART) used for serial data communications. Its principal function is to convert parallel data into serial data and vice versa. The UART can handle serial data rates up to 5 Mbit/s.

The SC16C2550B is pin compatible with the ST16C2550. It will power-up to be functionally equivalent to the 16C2450. The SC16C2550B provides enhanced UART functions with 16-byte FIFOs, modem control interface, DMA mode data transfer. The DMA mode data transfer is controlled by the FIFO trigger levels and the $\overline{\text{TXRDYn}}$ and $\overline{\text{RXRDYn}}$ signals. On-board status registers provide the user with error indications and operational status. System interrupts and modem control features may be tailored by software to meet specific user requirements. An internal loopback capability allows on-board diagnostics. Independent programmable baud rate generators are provided to select transmit and receive baud rates.

The SC16C2550B operates at 5 V, 3.3 V and 2.5 V and the industrial temperature range, and is available in plastic PLCC44, LQFP48, DIP40 and HVQFN32 packages.

2. Features

- 2 channel UART
- 5 V, 3.3 V and 2.5 V operation
- 5 V tolerant on input only pins¹
- Industrial temperature range
- Pin and functionally compatible to 16C2450 and software compatible with INS8250, SC16C550
- Up to 5 Mbit/s data rate at 5 V and 3.3 V and 3 Mbit/s at 2.5 V
- 16-byte transmit FIFO to reduce the bandwidth requirement of the external CPU
- 16-byte receive FIFO with error flags to reduce the bandwidth requirement of the external CPU
- Independent transmit and receive UART control
- Four selectable Receive FIFO interrupt trigger levels
- Software selectable baud rate generator
- Standard asynchronous error and framing bits (Start, Stop and Parity Overrun Break)
- Transmit, Receive, Line Status and Data Set interrupts independently controlled

1. For data bus pins D7 to D0, see [Table 23 "Limiting values"](#).

- Fully programmable character formatting:
 - ◆ 5-bit, 6-bit, 7-bit or 8-bit characters
 - ◆ Even, odd or no-parity formats
 - ◆ 1, 1½ or 2-stop bit
 - ◆ Baud generation (DC to 5 Mbit/s)
- False start-bit detection
- Complete status reporting capabilities
- 3-state output TTL drive capabilities for bidirectional data bus and control bus
- Line break generation and detection
- Internal diagnostic capabilities:
 - ◆ Loopback controls for communications link fault isolation
- Prioritized interrupt system controls
- Modem control functions ($\overline{\text{CTS}}$, $\overline{\text{RTS}}$, $\overline{\text{DSR}}$, $\overline{\text{DTR}}$, $\overline{\text{RI}}$, $\overline{\text{DCD}}$)

3. Ordering information

Table 1. Ordering information

| Type number | Package | | Version |
|----------------|---------|--|----------|
| | Name | Description | |
| SC16C2550BIA44 | PLCC44 | plastic leaded chip carrier; 44 leads | SOT187-2 |
| SC16C2550BIBS | HVQFN32 | plastic thermal enhanced very thin quad flat package; no leads; 32 terminals; body 5 × 5 × 0.85 mm | SOT617-1 |
| SC16C2550BIB48 | LQFP48 | plastic low profile quad flat package; 48 leads; body 7 × 7 × 1.4 mm | SOT313-2 |
| SC16C2550BIN40 | DIP40 | plastic dual in-line package; 40 leads (600 mil) | SOT129-1 |

3.1 Ordering options

Table 2. Ordering options

| Type number | Topside mark |
|----------------|----------------|
| SC16C2550BIA44 | SC16C2550BIA44 |
| SC16C2550BIBS | 2550B |
| SC16C2550BIB48 | 16C2550B |
| SC16C2550BIN40 | SC16C2550BIN40 |

4. Block diagram

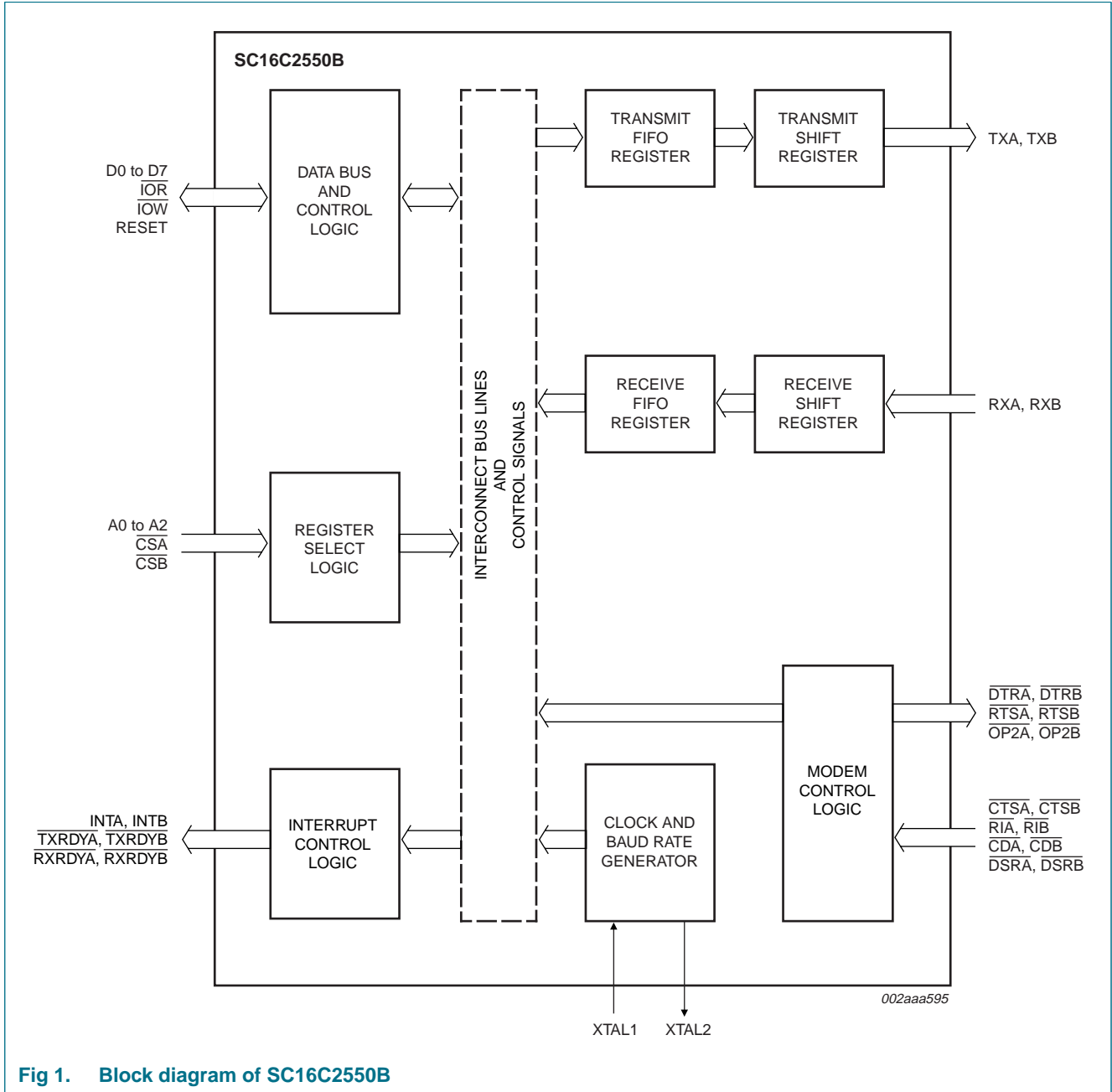
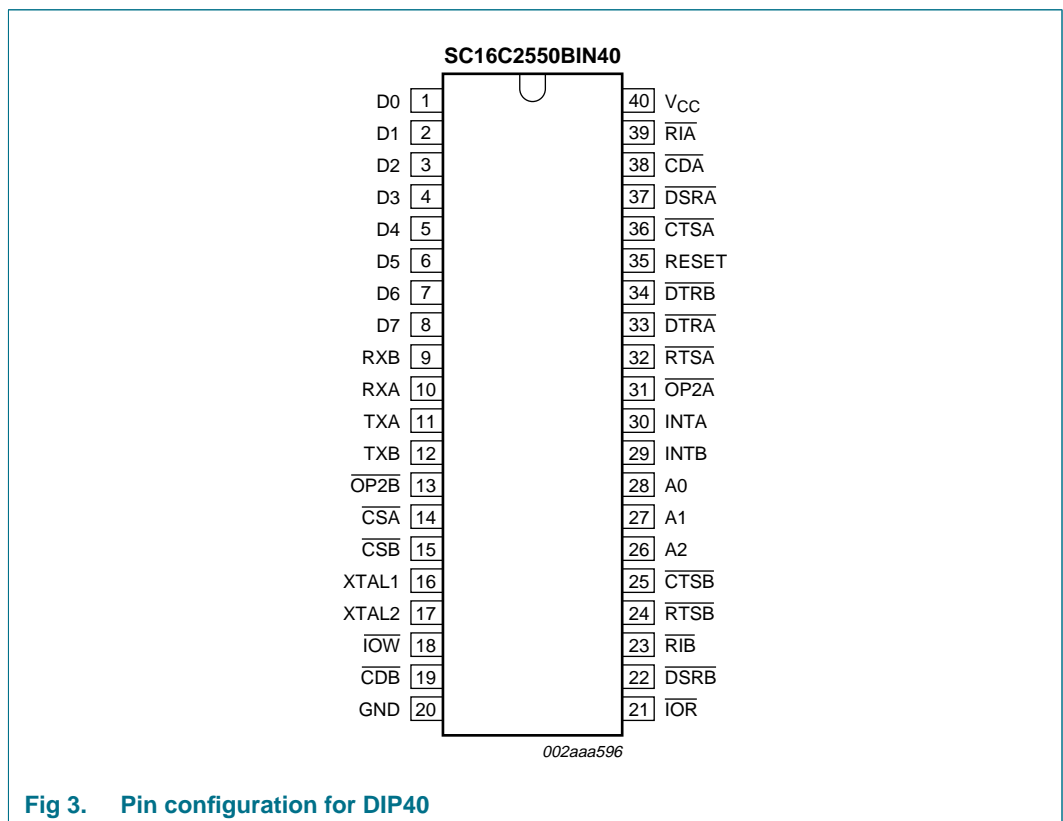
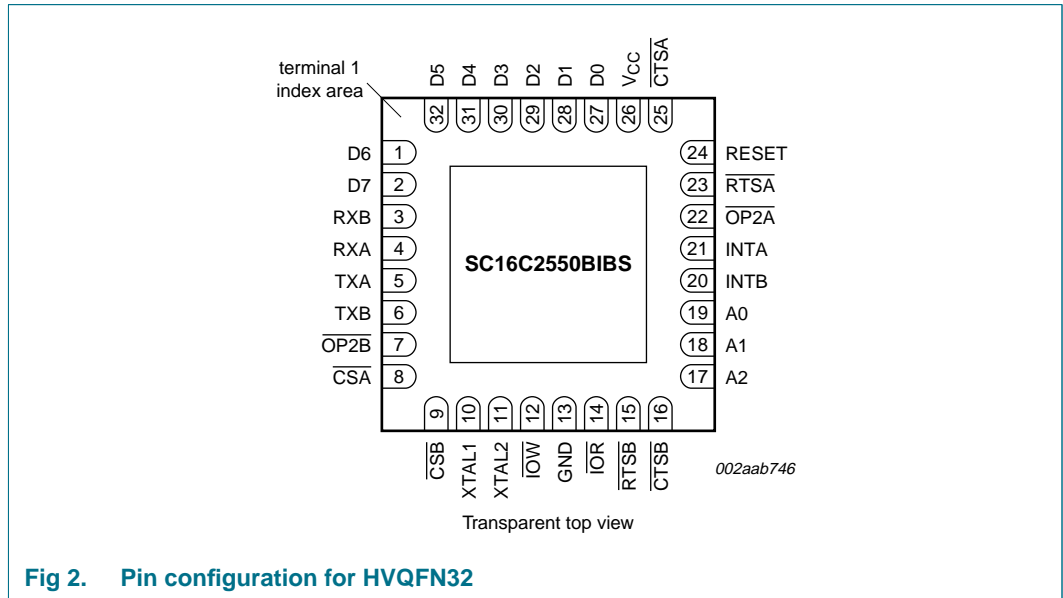

Fig 1. Block diagram of SC16C2550B

5. Pinning information

5.1 Pinning



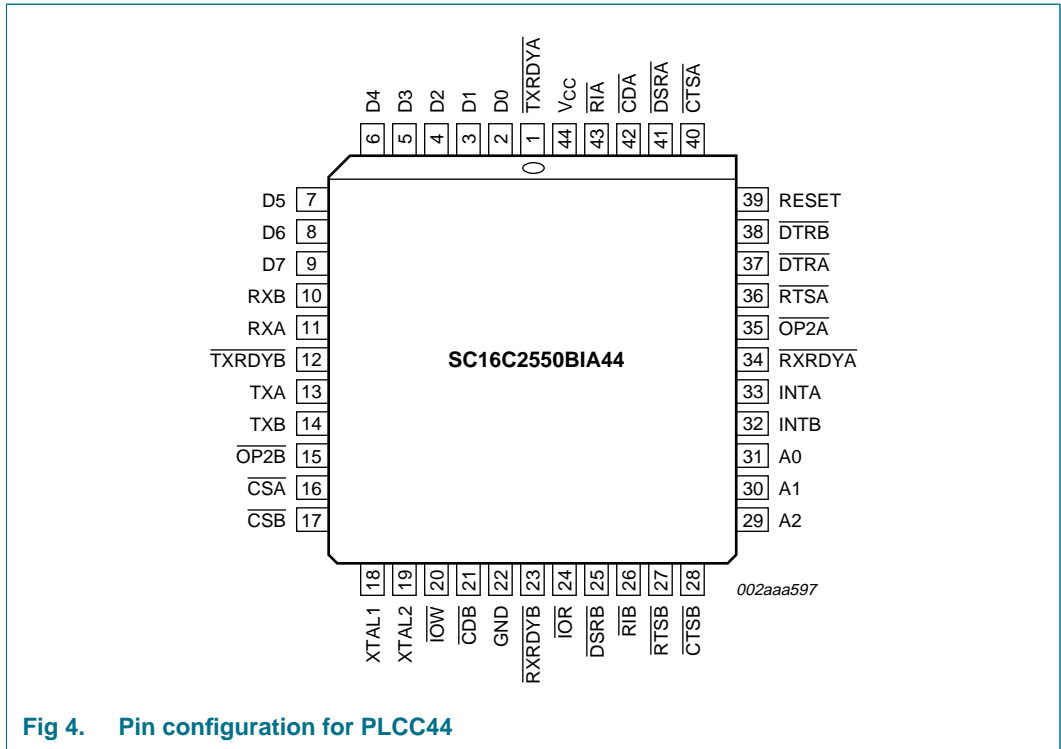

Fig 4. Pin configuration for PLCC44

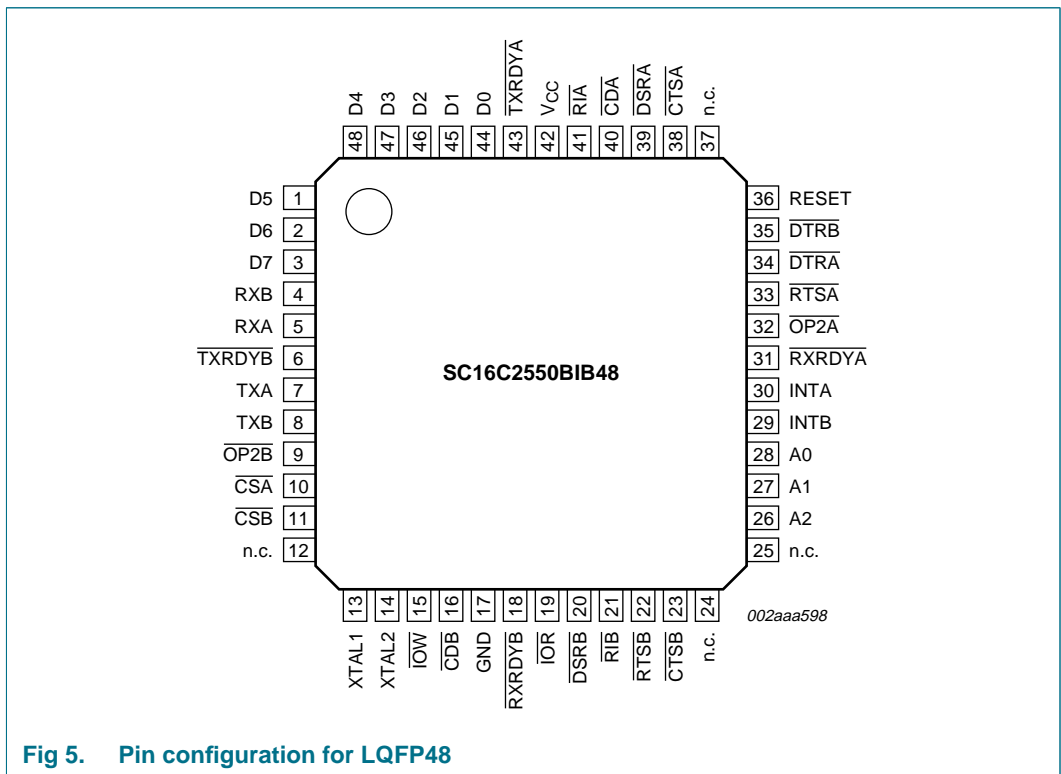

Fig 5. Pin configuration for LQFP48

5.2 Pin description

Table 3. Pin description

| Symbol | Pin | | | | Type | Description |
|--------------------------|---------|-------|--------|--------|------|---|
| | HVQFN32 | DIP40 | PLCC44 | LQFP48 | | |
| A0 | 19 | 28 | 31 | 28 | I | Address 0 select bit. Internal register address selection. |
| A1 | 18 | 27 | 30 | 27 | I | Address 1 select bit. Internal register address selection. |
| A2 | 17 | 26 | 29 | 26 | I | Address 2 select bit. Internal register address selection. |
| $\overline{\text{CSA}}$ | 8 | 14 | 16 | 10 | I | Chip Select A, B (active LOW). This function is associated with individual channels, A through B. These pins enable data transfers between the user CPU and the SC16C2550B for the channel(s) addressed. Individual UART sections (A, B) are addressed by providing a logic 0 on the respective $\overline{\text{CSA}}$, $\overline{\text{CSB}}$ pin. |
| $\overline{\text{CSB}}$ | 9 | 15 | 17 | 11 | I | |
| D0 | 27 | 1 | 2 | 44 | I/O | Data bus (bidirectional). These pins are the 8-bit, 3-state data bus for transferring information to or from the controlling CPU. D0 is the least significant bit and the first data bit in a transmit or receive serial data stream. |
| D1 | 28 | 2 | 3 | 45 | I/O | |
| D2 | 29 | 3 | 4 | 46 | I/O | |
| D3 | 30 | 4 | 5 | 47 | I/O | |
| D4 | 31 | 5 | 6 | 48 | I/O | |
| D5 | 32 | 6 | 7 | 1 | I/O | |
| D6 | 1 | 7 | 8 | 2 | I/O | |
| D7 | 2 | 8 | 9 | 3 | I/O | |
| GND | 13 | 20 | 22 | 17 | I | Signal and power ground. |
| INTA | 21 | 30 | 33 | 30 | O | Interrupt A, B (3-state). This function is associated with individual channel interrupts, INTA, INTB. INTA, INTB are enabled when MCR bit 3 is set to a logic 1, interrupts are enabled in the Interrupt Enable Register (IER) and is active when an interrupt condition exists. Interrupt conditions include: receiver errors, available receiver buffer data, transmit buffer empty or when a modem status flag is detected. |
| INTB | 20 | 29 | 32 | 29 | O | |
| $\overline{\text{IOR}}$ | 14 | 21 | 24 | 19 | I | Read strobe (active LOW strobe). A logic 0 transition on this pin will load the contents of an internal register defined by address bits A0 to A2 onto the SC16C2550B data bus (D0 to D7) for access by external CPU. |
| $\overline{\text{IOW}}$ | 12 | 18 | 20 | 15 | I | Write strobe (active LOW strobe). A logic 0 transition on this pin will transfer the contents of the data bus (D0 to D7) from the external CPU to an internal register that is defined by address bits A0 to A2. |
| $\overline{\text{OP2A}}$ | 22 | 31 | 35 | 32 | O | Output 2 (user-defined). This function is associated with individual channels, A through B. The state at these pin(s) are defined by the user and through MCR register bit 3. INTA, INTB are set to the active mode and $\overline{\text{OP2}}$ to logic 0 when MCR[3] is set to a logic 1. INTA, INTB are set to the 3-state mode and $\overline{\text{OP2}}$ to a logic 1 when MCR[3] is set to a logic 0. See Table 18 "Modem Control Register bits description" , bit 3 (MCR[3]). Since these bits control both the INTA, INTB operation and $\overline{\text{OP2}}$ outputs, only one function should be used at one time, INT or $\overline{\text{OP2}}$. |
| $\overline{\text{OP2B}}$ | 7 | 13 | 15 | 9 | O | |

Table 3. Pin description ...continued

| Symbol | Pin | | | | Type | Description |
|-----------------|---------|-------|--------|--------|------|---|
| | HVQFN32 | DIP40 | PLCC44 | LQFP48 | | |
| RESET | 24 | 35 | 39 | 36 | I | Reset (active HIGH). A logic 1 on this pin will reset the internal registers and all the outputs. The UART transmitter output and the receiver input will be disabled during reset time. (See Section 7.10 "SC16C2550B external reset condition" for initialization details.) |
| RXRDYA | - | - | 34 | 31 | O | Receive Ready A, B (active LOW). This function is associated with PLCC44 and LQFP48 packages only. This function provides the RX FIFO/RHR status for individual receive channels (A-B). RXRDY \bar{n} is primarily intended for monitoring DMA mode 1 transfers for the receive data FIFOs. A logic 0 indicates there is a receive data to read/upload, that is, receive ready status with one or more RX characters available in the FIFO/RHR. This pin is a logic 1 when the FIFO/RHR is empty or when the programmed trigger level has not been reached. This signal can also be used for single mode transfers (DMA mode 0). |
| RXRDYB | - | - | 23 | 18 | O | |
| TXRDYA | - | - | 1 | 43 | O | Transmit Ready A, B (active LOW). This function is associated with PLCC44 and LQFP48 packages only. These outputs provide the TX FIFO/THR status for individual transmit channels (A, B). TXRDY \bar{n} is primarily intended for monitoring DMA mode 1 transfers for the transmit data FIFOs. An individual channel's TXRDYA, TXRDYB buffer ready status is indicated by logic 0, that is, at least one location is empty and available in the FIFO or THR. This pin goes to a logic 1 (DMA mode 1) when there are no more empty locations in the FIFO or THR. This signal can also be used for single mode transfers (DMA mode 0). |
| TXRDYB | - | - | 12 | 6 | O | |
| V _{CC} | 26 | 40 | 44 | 42 | I | Power supply input. |
| XTAL1 | 10 | 16 | 18 | 13 | I | Crystal or external clock input. Functions as a crystal input or as an external clock input. A crystal can be connected between this pin and XTAL2 to form an internal oscillator circuit. Alternatively, an external clock can be connected to this pin to provide custom data rates. (See Section 6.5 "Programmable baud rate generator" .) See Figure 6 . |
| XTAL2 | 11 | 17 | 19 | 14 | O | Output of the crystal oscillator or buffered clock. (See also XTAL1.) Crystal oscillator output or buffered clock output. Should be left open if an external clock is connected to XTAL1. For extended frequency operation, this pin should be tied to V _{CC} via a 2 k Ω resistor. |
| CDA | - | 38 | 42 | 40 | I | Carrier Detect (active LOW). These inputs are associated with individual UART channels A through B. A logic 0 on this pin indicates that a carrier has been detected by the modem for that channel. |
| CDB | - | 19 | 21 | 16 | I | |
| CTSA | 25 | 36 | 40 | 38 | I | Clear to Send (active LOW). These inputs are associated with individual UART channels, A through B. A logic 0 on the CTS \bar{n} pin indicates the modem or data set is ready to accept transmit data from the SC16C2550B. Status can be tested by reading MSR[4]. This pin has no effect on the UART's transmit or receive operation. |
| CTSB | 16 | 25 | 28 | 23 | I | |

Table 3. Pin description ...continued

| Symbol | Pin | | | | Type | Description |
|--------------------------|---------|-------|--------|-------------------|------|---|
| | HVQFN32 | DIP40 | PLCC44 | LQFP48 | | |
| $\overline{\text{DSRA}}$ | - | 37 | 41 | 39 | I | Data Set Ready (active LOW). These inputs are associated with individual UART channels, A through B. A logic 0 on this pin indicates the modem or data set is powered-on and is ready for data exchange with the UART. This pin has no effect on the UART's transmit or receive operation. |
| $\overline{\text{DSRB}}$ | - | 22 | 25 | 20 | I | |
| $\overline{\text{DTRA}}$ | - | 33 | 37 | 34 | O | Data Terminal Ready (active LOW). These outputs are associated with individual UART channels, A through B. A logic 0 on this pin indicates that the SC16C2550B is powered-on and ready. This pin can be controlled via the Modem Control Register. Writing a logic 1 to MCR[0] will set the $\overline{\text{DTRn}}$ output to logic 0, enabling the modem. This pin will be a logic 1 after writing a logic 0 to MCR[0] or after a reset. This pin has no effect on the UART's transmit or receive operation. |
| $\overline{\text{DTRB}}$ | - | 34 | 38 | 35 | O | |
| $\overline{\text{RIA}}$ | - | 39 | 43 | 41 | I | Ring Indicator (active LOW). These inputs are associated with individual UART channels, A through B. A logic 0 on this pin indicates the modem has received a ringing signal from the telephone line. A logic 1 transition on this input pin will generate an interrupt. |
| $\overline{\text{RIB}}$ | - | 23 | 26 | 21 | I | |
| $\overline{\text{RTSA}}$ | 23 | 32 | 36 | 33 | O | Request to Send (active LOW). These outputs are associated with individual UART channels, A through B. A logic 0 on the $\overline{\text{RTSn}}$ pin indicates the transmitter has data ready and waiting to send. Writing a logic 1 in the Modem Control Register MCR[1] will set this pin to a logic 0, indicating data is available. After a reset this pin will be set to a logic 1. This pin has no effect on the UART's transmit or receive operation. |
| $\overline{\text{RTSB}}$ | 15 | 24 | 27 | 22 | O | |
| RXA | 4 | 10 | 11 | 5 | I | Receive data A, B. These inputs are associated with individual serial channel data to the SC16C2550B receive input circuits, A and B. The RXn signal will be a logic 1 during reset, idle (no data) or when the transmitter is disabled. During the local Loopback mode, the RXn input pin is disabled and TX data is connected to the UART RX input, internally. |
| RXB | 3 | 9 | 10 | 4 | I | |
| TXA | 5 | 11 | 13 | 7 | O | Transmit data A, B. These outputs are associated with individual serial transmit channel data from the SC16C2550B. The TXn signal will be a logic 1 during reset, idle (no data) or when the transmitter is disabled. During the local Loopback mode, the TXn output pin is disabled and TX data is internally connected to the UART RX input. |
| TXB | 6 | 12 | 14 | 8 | O | |
| n.c. | - | - | - | 12, 24, 25, 37 | - | not connected |

6. Functional description

The SC16C2550B provides serial asynchronous receive data synchronization, parallel-to-serial and serial-to-parallel data conversions for both the transmitter and receiver sections. These functions are necessary for converting the serial data stream into parallel data that is required with digital data systems. Synchronization for the serial data stream is accomplished by adding start and stop bits to the transmit data to form a data character (character orientated protocol). Data integrity is insured by attaching a parity bit to the data character. The parity bit is checked by the receiver for any transmission bit errors. The electronic circuitry to provide all these functions is fairly complex, especially when manufactured on a single integrated silicon chip. The SC16C2550B represents such an integration with greatly enhanced features. The SC16C2550B is fabricated with an advanced CMOS process.

The SC16C2550B is an upward solution that provides a dual UART capability with 16 bytes of transmit and receive FIFO memory, instead of none in the 16C2450. The SC16C2550B is designed to work with high speed modems and shared network environments that require fast data processing time. Increased performance is realized in the SC16C2550B by the transmit and receive FIFOs. This allows the external processor to handle more networking tasks within a given time. For example, the ST16C2450 without a receive FIFO, will require unloading of the RHR in 93 microseconds (this example uses a character length of 11 bits, including start/stop bits at 115.2 kbit/s). This means the external CPU will have to service the receive FIFO less than every 100 microseconds. However, with the 16-byte FIFO in the SC16C2550B, the data buffer will not require unloading/loading for 1.53 ms. This increases the service interval, giving the external CPU additional time for other applications and reducing the overall UART interrupt servicing time. In addition, the four selectable receive FIFO trigger interrupt levels are uniquely provided for maximum data throughput performance especially when operating in a multi-channel environment. The FIFO memory greatly reduces the bandwidth requirement of the external controlling CPU, increases performance and reduces power consumption.

The SC16C2550B is capable of operation up to 5 Mbit/s with a 80 MHz clock. With a crystal or external clock input of 7.3728 MHz, the user can select data rates up to 460.8 kbit/s.

The rich feature set of the SC16C2550B is available through internal registers. Selectable receive FIFO trigger levels, selectable TX and RX baud rates and modem interface controls are all standard features. Following a power-on reset or an external reset, the SC16C2550B is software compatible with the previous generation, ST16C2450.

6.1 UART A-B functions

The UART provides the user with the capability to bidirectionally transfer information between an external CPU, the SC16C2550B package and an external serial device. A logic 0 on chip select pins \overline{CSA} and/or \overline{CSB} allows the user to configure, send data, and/or receive data via UART channels A through B. Individual channel select functions are shown in [Table 4](#).

Table 4. Serial port selection

| Chip Select | Function |
|--------------------------------------|----------------|
| $\overline{CSA}, \overline{CSB} = 1$ | none |
| $\overline{CSA} = 0$ | UART channel A |
| $\overline{CSB} = 0$ | UART channel B |

6.2 Internal registers

The SC16C2550B provides two sets of internal registers (A and B) consisting of 12 registers each for monitoring and controlling the functions of each channel of the UART. These registers are shown in [Table 5](#). The UART registers function as data holding registers (THR/RHR), interrupt status and control registers (IER/ISR), a FIFO Control Register (FCR), line status and control registers (LCR/LSR), modem status and control registers (MCR/MSR), programmable data rate (clock) control registers (DLL/DLM) and a user-accessible Scratchpad Register (SPR).

Table 5. Internal registers decoding

| A2 | A1 | A0 | READ mode | WRITE mode |
|--|----|----|---------------------------|---------------------------|
| General register set (THR/RHR, IER/ISR, MCR/MSR, FCR, LCR/LSR, SPR)^[1] | | | | |
| 0 | 0 | 0 | Receive Holding Register | Transmit Holding Register |
| 0 | 0 | 1 | Interrupt Enable Register | Interrupt Enable Register |
| 0 | 1 | 0 | Interrupt Status Register | FIFO Control Register |
| 0 | 1 | 1 | Line Control Register | Line Control Register |
| 1 | 0 | 0 | Modem Control Register | Modem Control Register |
| 1 | 0 | 1 | Line Status Register | n/a |
| 1 | 1 | 0 | Modem Status Register | n/a |
| 1 | 1 | 1 | Scratchpad Register | Scratchpad Register |
| Baud rate register set (DLL/DLM)^[2] | | | | |
| 0 | 0 | 0 | LSB of Divisor Latch | LSB of Divisor Latch |
| 0 | 0 | 1 | MSB of Divisor Latch | MSB of Divisor Latch |

[1] These registers are accessible only when LCR[7] is a logic 0.

[2] These registers are accessible only when LCR[7] is a logic 1.

6.3 FIFO operation

The 16-byte transmit and receive data FIFOs are enabled by the FIFO Control Register (FCR) bit 0. The user can set the receive trigger level via FCR bits 7:6, but not the transmit trigger level. The receiver FIFO section includes a time-out function to ensure data is delivered to the external CPU. An interrupt is generated whenever the Receive Holding Register (RHR) has not been read following the loading of a character or the receive trigger level has not been reached.

Table 6. Flow control mechanism

| Selected trigger level (characters) | INTn pin activation |
|-------------------------------------|---------------------|
| 1 | 1 |
| 4 | 4 |
| 8 | 8 |
| 14 | 14 |

6.4 Hardware/software and time-out interrupts

The interrupts are enabled by IER[3:0]. Care must be taken when handling these interrupts. Following a reset, if Interrupt Enable Register (IER) bit 1 = 1, the SC16C2550B will issue a Transmit Holding Register interrupt. This interrupt must be serviced prior to continuing operations. The ISR register provides the current singular highest priority interrupt only. A condition can exist where a higher priority interrupt may mask the lower priority interrupt(s). Only after servicing the higher pending interrupt will the lower priority interrupt(s) be reflected in the status register. Servicing the interrupt without investigating further interrupt conditions can result in data errors.

When two interrupt conditions have the same priority, it is important to service these interrupts correctly. Receive Data Ready and Receive Time Out have the same interrupt priority (when enabled by IER[0]). The receiver issues an interrupt after the number of characters have reached the programmed trigger level. In this case, the SC16C2550B FIFO may hold more characters than the programmed trigger level. Following the removal of a data byte, the user should re-check LSR[0] for additional characters. A Receive Time Out will not occur if the receive FIFO is empty. The time-out counter is reset at the center of each stop bit received or each time the Receive Holding Register (RHR) is read. The actual time-out value is 4 character time, including data information length, start bit, parity bit and the size of stop bit, that is, 1×, 1.5× or 2× bit times.

6.5 Programmable baud rate generator

The SC16C2550B supports high speed modem technologies that have increased input data rates by employing data compression schemes. For example, a 33.6 kbit/s modem that employs data compression may require a 115.2 kbit/s input data rate. A 128.0 kbit/s ISDN modem that supports data compression may need an input data rate of 460.8 kbit/s. The SC16C2550B can support a standard data rate of 921.6 kbit/s.

A single baud rate generator is provided for the transmitter and receiver, allowing independent TX/RX channel control. The programmable baud rate generator is capable of operating with a frequency of up to 80 MHz. To obtain maximum data rate, it is necessary to use full rail swing on the clock input. The SC16C2550B can be configured for internal or external clock operation. For internal clock oscillator operation, an industry standard microprocessor crystal is connected externally between the XTAL1 and XTAL2 pins. Alternatively, an external clock can be connected to the XTAL1 pin to clock the internal baud rate generator for standard or custom rates (see [Table 7](#)).

The generator divides the input 16× clock by any divisor from 1 to (2¹⁶ – 1). The SC16C2550B divides the basic external clock by 16. The basic 16× clock provides table rates to support standard and custom applications using the same system design. The rate table is configured via the DLL and DLM internal register functions. Customized baud rates can be achieved by selecting the proper divisor values for the MSB and LSB sections of baud rate generator.

Programming the baud rate generator registers DLM (MSB) and DLL (LSB) provides a user capability for selecting the desired final baud rate. The example in [Table 7](#) shows the selectable baud rate table available when using a 1.8432 MHz external clock input.

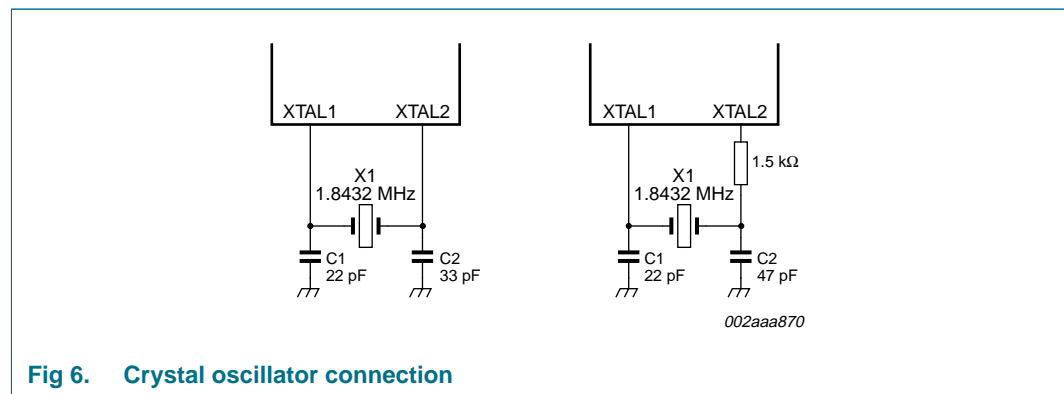

Fig 6. Crystal oscillator connection

Table 7. Baud rate generator programming table using a 1.8432 MHz clock

| Output baud rate (bit/s) | Output 16× clock divisor (decimal) | Output 16× clock divisor (hexadecimal) | DLM program value (hexadecimal) | DLL program value (hexadecimal) |
|--------------------------|------------------------------------|--|---------------------------------|---------------------------------|
| 50 | 2304 | 900 | 09 | 00 |
| 75 | 1536 | 600 | 06 | 00 |
| 110 | 1047 | 417 | 04 | 17 |
| 150 | 768 | 300 | 03 | 00 |
| 300 | 384 | 180 | 01 | 80 |
| 600 | 192 | C0 | 00 | C0 |
| 1200 | 96 | 60 | 00 | 60 |
| 2400 | 48 | 30 | 00 | 30 |
| 3600 | 32 | 20 | 00 | 20 |
| 4800 | 24 | 18 | 00 | 18 |
| 7200 | 16 | 10 | 00 | 10 |
| 9600 | 12 | 0C | 00 | 0C |
| 19.2 k | 6 | 06 | 00 | 06 |
| 38.4 k | 3 | 03 | 00 | 03 |
| 57.6 k | 2 | 02 | 00 | 02 |
| 115.2 k | 1 | 01 | 00 | 01 |

6.6 DMA operation

The SC16C2550B FIFO trigger level provides additional flexibility to the user for block mode operation. LSR[6:5] provide an indication when the transmitter is empty or has an empty location(s). The user can optionally operate the transmit and receive FIFOs in the DMA mode (FCR[3]). When the transmit and receive FIFOs are enabled and the DMA mode is de-activated (DMA Mode 0), the SC16C2550B activates the interrupt output pin (INTn) for each data transmit or receive operation. When DMA mode is activated (DMA Mode 1), the user takes the advantage of block mode operation by loading or unloading the FIFO in a block sequence determined by the receive trigger level and the transmit FIFO. In this mode, the SC16C2550B sets the $\overline{\text{TXRDYn}}$ (or $\overline{\text{RXRDYn}}$) output pin when characters in the transmit FIFO is below 16 or the characters in the receive FIFOs are above the receive trigger level.

6.7 Loopback mode

The internal loopback capability allows on-board diagnostics. In the Loopback mode, the normal modem interface pins are disconnected and reconfigured for loopback internally (see [Figure 7](#)). MCR[3:0] register bits are used for controlling loopback diagnostic testing. In the Loopback mode, the transmitter output (TX) and the receiver input (RX) are disconnected from their associated interface pins and instead are connected together internally. The $\overline{\text{CTS}}$, $\overline{\text{DSR}}$, $\overline{\text{CD}}$ and $\overline{\text{RI}}$ are disconnected from their normal modem control input pins and instead are connected internally to $\overline{\text{RTS}}$, $\overline{\text{DTR}}$, MCR[3] ($\overline{\text{OP2}}$) and MCR[2] ($\overline{\text{OP1}}$). Loopback test data is entered into the transmit holding register via the user data bus interface, D0 through D7. The transmit UART serializes the data and passes the serial data to the receive UART via the internal loopback connection. The receive UART

converts the serial data back into parallel data that is then made available at the user data interface D0 through D7. The user optionally compares the received data to the initial transmitted data for verifying error-free operation of the UART TX/RX circuits.

In this mode, the receiver and transmitter interrupts are fully operational. The modem control interrupts are also operational.

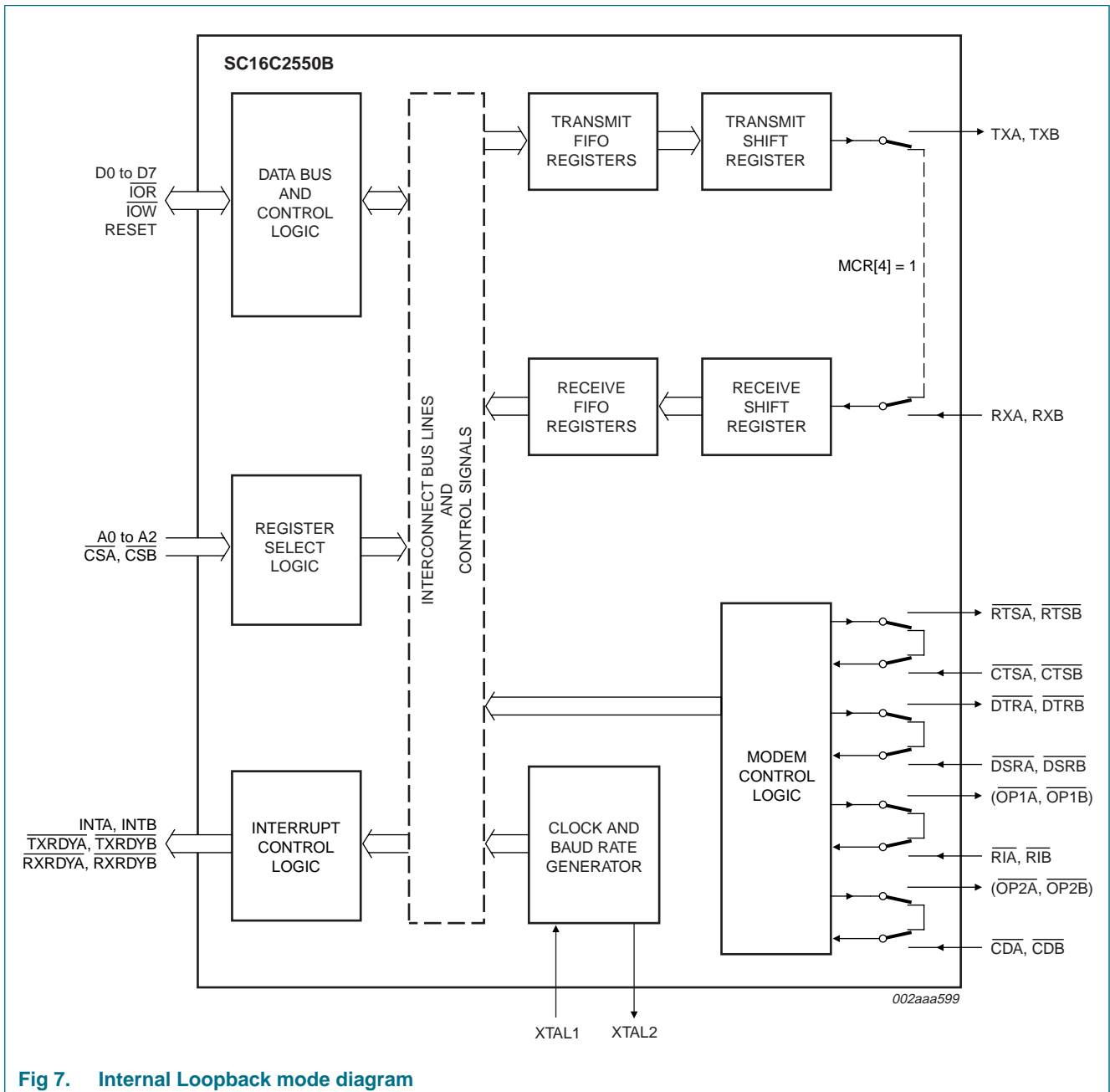

Fig 7. Internal Loopback mode diagram

7. Register descriptions

[Table 8](#) details the assigned bit functions for the SC16C2550B internal registers. The assigned bit functions are more fully defined in [Section 7.1](#) through [Section 7.10](#).

Table 8. SC16C2550B internal registers

| A2 | A1 | A0 | Register | Default ^[1] | Bit 7 | Bit 6 | Bit 5 | Bit 4 | Bit 3 | Bit 2 | Bit 1 | Bit 0 |
|---|----|----|----------|------------------------|----------------------|--------------------|------------|-----------------|------------------------|-------------------------------|-------------------------------------|--------------------------|
| General register set^[2] | | | | | | | | | | | | |
| 0 | 0 | 0 | RHR | XX | bit 7 | bit 6 | bit 5 | bit 4 | bit 3 | bit 2 | bit 1 | bit 0 |
| 0 | 0 | 0 | THR | XX | bit 7 | bit 6 | bit 5 | bit 4 | bit 3 | bit 2 | bit 1 | bit 0 |
| 0 | 0 | 1 | IER | 00 | 0 | 0 | 0 | 0 | modem status interrupt | receive line status interrupt | transmit holding register interrupt | receive holding register |
| 0 | 1 | 0 | FCR | 00 | RCVR trigger (MSB) | RCVR trigger (LSB) | reserved 0 | reserved 0 | DMA mode select | XMIT FIFO reset | RCVR FIFO reset | FIFOs enable |
| 0 | 1 | 0 | ISR | 01 | FIFOs enabled | FIFOs enabled | 0 | 0 | INT priority bit 2 | INT priority bit 1 | INT priority bit 0 | INT status |
| 0 | 1 | 1 | LCR | 00 | divisor latch enable | set break | set parity | even parity | parity enable | stop bits | word length bit 1 | word length bit 0 |
| 1 | 0 | 0 | MCR | 00 | 0 | 0 | 0 | loop back | OP2/INT enable | ($\overline{OP1}$) | RTS | DTR |
| 1 | 0 | 1 | LSR | 60 | FIFO data error | THR and TSR empty | THR empty | break interrupt | framing error | parity error | overrun error | receive data ready |
| 1 | 1 | 0 | MSR | X0 | CD | RI | DSR | CTS | $\Delta\overline{CD}$ | $\Delta\overline{RI}$ | $\Delta\overline{DSR}$ | $\Delta\overline{CTS}$ |
| 1 | 1 | 1 | SPR | FF | bit 7 | bit 6 | bit 5 | bit 4 | bit 3 | bit 2 | bit 1 | bit 0 |
| Special register set^[3] | | | | | | | | | | | | |
| 0 | 0 | 0 | DLL | XX | bit 7 | bit 6 | bit 5 | bit 4 | bit 3 | bit 2 | bit 1 | bit 0 |
| 0 | 0 | 1 | DLM | XX | bit 15 | bit 14 | bit 13 | bit 12 | bit 11 | bit 10 | bit 9 | bit 8 |

[1] The value shown represents the register's initialized hexadecimal value; X = not applicable.

[2] Accessible only when LCR[7] is logic 0.

[3] Baud rate registers accessible only when LCR[7] is logic 1.

7.1 Transmit Holding Register (THR) and Receive Holding Register (RHR)

The serial transmitter section consists of an 8-bit Transmit Hold Register (THR) and Transmit Shift Register (TSR). The status of the THR is provided in the Line Status Register (LSR). Writing to the THR transfers the contents of the data bus (D7 through D0) to the TSR and UART via the THR, providing that the THR is empty. The THR empty flag in the LSR register will be set to a logic 1 when the transmitter is empty or when data is transferred to the TSR. Note that a write operation can be performed when the THR empty flag is set (logic 0 = at least one byte in FIFO/THR, logic 1 = FIFO/THR empty).

The serial receive section also contains an 8-bit Receive Holding Register (RHR) and a Receive Serial Shift Register (RSR). Receive data is removed from the SC16C2550B and receive FIFO by reading the RHR register. The receive section provides a mechanism to

prevent false starts. On the falling edge of a start or false start bit, an internal receiver counter starts counting clocks at the 16× clock rate. After 7½ clocks, the start bit time should be shifted to the center of the start bit. At this time the start bit is sampled and if it is still a logic 0 it is validated. Evaluating the start bit in this manner prevents the receiver from assembling a false character. Receiver status codes will be posted in the LSR.

7.2 Interrupt Enable Register (IER)

The Interrupt Enable Register (IER) masks the interrupts from receiver ready, transmitter empty, line status and modem status registers. These interrupts would normally be seen on the INTA, INTB output pins.

Table 9. Interrupt Enable Register bits description

| Bit | Symbol | Description |
|-----|----------|--|
| 7:4 | IER[7:4] | not used |
| 3 | IER[3] | Modem Status Interrupt. This interrupt will be issued whenever there is a modem status change as reflected in MSR[3:0]. logic 0 = disable the Modem Status Register interrupt (normal default condition) logic 1 = enable the Modem Status Register interrupt |
| 2 | IER[2] | Receive Line Status interrupt. This interrupt will be issued whenever a receive data error condition exists as reflected in LSR[4:1]. logic 0 = disable the receiver line status interrupt (normal default condition) logic 1 = enable the receiver line status interrupt |
| 1 | IER[1] | Transmit Holding Register interrupt. In the 16C450 mode, this interrupt will be issued whenever the THR is empty and is associated with LSR[5]. In the FIFO modes, this interrupt will be issued whenever the FIFO is empty. logic 0 = disable the Transmit Holding Register Empty (TXRDY) interrupt (normal default condition) logic 1 = enable the TXRDY (ISR level 3) interrupt |
| 0 | IER[0] | Receive Holding Register. In the 16C450 mode, this interrupt will be issued when the RHR has data or is cleared when the RHR is empty. In the FIFO mode, this interrupt will be issued when the FIFO has reached the programmed trigger level or is cleared when the FIFO drops below the trigger level. logic 0 = disable the receiver ready (ISR level 2, RXRDY) interrupt (normal default condition) logic 1 = enable the RXRDY (ISR level 2) interrupt |

7.2.1 IER versus Transmit/Receive FIFO interrupt mode operation

When the receive FIFO (FCR[0] = logic 1) and receive interrupts (IER[0] = logic 1) are enabled, the receive interrupts and register status will reflect the following:

- The receive RXRDY interrupt (Level 2 ISR interrupt) is issued to the external CPU when the receive FIFO has reached the programmed trigger level. It will be cleared when the receive FIFO drops below the programmed trigger level.
- Receive FIFO status will also be reflected in the user accessible ISR register when the receive FIFO trigger level is reached. Both the ISR register receive status bit and the interrupt will be cleared when the FIFO drops below the trigger level.
- The receive data ready bit (LSR[0]) is set as soon as a character is transferred from the shift register (RSR) to the receive FIFO. It is reset when the FIFO is empty.
- When the Transmit FIFO and interrupts are enabled, an interrupt is generated when the transmit FIFO is empty due to the unloading of the data by the TSR and UART for transmission via the transmission media. The interrupt is cleared either by reading the ISR register or by loading the THR with new data characters.

7.2.2 IER versus Receive/Transmit FIFO polled mode operation

When FCR[0] = logic 1, resetting IER[3:0] enables the SC16C2550B in the FIFO polled mode of operation. In this mode, interrupts are not generated and the user must poll the LSR register for TX and/or RX data status. Since the receiver and transmitter have separate bits in the LSR either or both can be used in the polled mode by selecting respective transmit or receive control bit(s).

- LSR[0] will be a logic 1 as long as there is one byte in the receive FIFO.
- LSR[4:1] will provide the type of receive errors or a receive break, if encountered.
- LSR[5] will indicate when the transmit FIFO is empty.
- LSR[6] will indicate when both the transmit FIFO and transmit shift register are empty.
- LSR[7] will show if any FIFO data errors occurred.

7.3 FIFO Control Register (FCR)

This register is used to enable the FIFOs, clear the FIFOs, set the receive FIFO trigger levels and select the DMA mode.

7.3.1 DMA mode

7.3.1.1 Mode 0 (FCR bit 3 = 0)

Set and enable the interrupt for each single transmit or receive operation and is similar to the 16C450 mode. Transmit Ready ($\overline{\text{TXRDYn}}$) on PLCC44 and LQFP48 packages will go to a logic 0 whenever the FIFO (THR, if FIFO is not enabled) is empty. Receive Ready ($\overline{\text{RXRDYn}}$) on PLCC44 and LQFP48 packages will go to a logic 0 whenever the Receive Holding Register (RHR) is loaded with a character.

7.3.1.2 Mode 1 (FCR bit 3 = 1)

Set and enable the interrupt in a block mode operation. The transmit interrupt is set when the transmit FIFO is empty. $\overline{\text{TXRDYn}}$ on PLCC44 and LQFP48 packages remains a logic 0 as long as one empty FIFO location is available. The receive interrupt is set when the receive FIFO fills to the programmed trigger level. However, the FIFO continues to fill

regardless of the programmed level until the FIFO is full. $\overline{\text{RXRDY}}$ on PLCC44 and LQFP48 packages transitions LOW when the FIFO reaches the trigger level and transitions HIGH when the FIFO empties.

7.3.2 FIFO mode

Table 10. FIFO Control Register bits description

| Bit | Symbol | Description |
|-----|----------|--|
| 7:6 | FCR[7:6] | <p>RCVR trigger. These bits are used to set the trigger level for the receive FIFO interrupt.</p> <p>logic 0 (or cleared) = normal default condition logic 1 = RX trigger level</p> <p>An interrupt is generated when the number of characters in the FIFO equals the programmed trigger level. However, the FIFO will continue to be loaded until it is full. Refer to Table 11.</p> |
| 5:4 | FCR[5:4] | Not used; initialized to logic 0. |
| 3 | FCR[3] | <p>DMA mode select.</p> <p>logic 0 = set DMA mode '0' logic 1 = set DMA mode '1'</p> <p>Transmit operation in mode '0': When the SC16C2550B is in the 16C450 mode (FIFOs disabled; FCR[0] = logic 0) or in the FIFO mode (FIFOs enabled; FCR[0] = logic 1; FCR[3] = logic 0) and when there are no characters in the transmit FIFO or Transmit Holding Register, the $\overline{\text{TXRDYn}}$ pin in PLCC44 or LQFP48 packages will be a logic 0. Once active, the $\overline{\text{TXRDYn}}$ pin will go to a logic 1 after the first character is loaded into the Transmit Holding Register.</p> <p>Receive operation in mode '0': When the SC16C2550B is in mode '0' (FCR[0] = logic 0) or in the FIFO mode (FCR[3] = logic 0) and there is at least one character in the receive FIFO, the $\overline{\text{RXRDYn}}$ pin will be a logic 0. Once active, the $\overline{\text{RXRDYn}}$ pin on PLCC44 and LQFP48 packages will go to a logic 1 when there are no more characters in the receiver.</p> <p>Transmit operation in mode '1': When the SC16C2550B is in FIFO mode (FCR[0] = logic 1; FCR[3] = logic 1), the $\overline{\text{TXRDYn}}$ pin on PLCC44 and LQFP48 packages will be a logic 1 when the transmit FIFO is completely full. It will be a logic 0 if one or more FIFO locations are empty.</p> <p>Receive operation in mode '1': When the SC16C2550B is in FIFO mode (FCR[0] = logic 1; FCR[3] = logic 1) and the trigger level has been reached or a Receive Time-out has occurred, the $\overline{\text{RXRDYn}}$ pin on PLCC44 and LQFP48 packages will go to a logic 0. Once activated, it will go to a logic 1 after there are no more characters in the FIFO.</p> |
| 2 | FCR[2] | <p>XMIT FIFO reset.</p> <p>logic 0 = Transmit FIFO not reset (normal default condition). logic 1 = clears the contents of the transmit FIFO and resets the FIFO counter logic (the Transmit Shift Register is not cleared or altered). This bit will return to a logic 0 after clearing the FIFO.</p> |

Table 10. FIFO Control Register bits description ...continued

| Bit | Symbol | Description |
|-----|--------|---|
| 1 | FCR[1] | RCVR FIFO reset. logic 0 = Receive FIFO not reset (normal default condition) logic 1 = clears the contents of the receive FIFO and resets the FIFO counter logic (the Receive Shift Register is not cleared or altered). This bit will return to a logic 0 after clearing the FIFO. |
| 0 | FCR[0] | FIFOs enabled. logic 0 = disable the transmit and receive FIFO (normal default condition) logic 1 = enable the transmit and receive FIFO. This bit must be a '1' when other FCR bits are written to or they will not be programmed. |

Table 11. RCVR trigger levels

| FCR[7] | FCR[6] | RX FIFO trigger level |
|--------|--------|-----------------------|
| 0 | 0 | 01 |
| 0 | 1 | 04 |
| 1 | 0 | 08 |
| 1 | 1 | 14 |

7.4 Interrupt Status Register (ISR)

The SC16C2550B provides four levels of prioritized interrupts to minimize external software interaction. The Interrupt Status Register (ISR) provides the user with four interrupt status bits. Performing a read cycle on the ISR will provide the user with the highest pending interrupt level to be serviced. No other interrupts are acknowledged until the pending interrupt is serviced. A lower level interrupt may be seen after servicing the higher level interrupt and re-reading the interrupt status bits. [Table 12 "Interrupt source"](#) shows the data values (bits 3:0) for the four prioritized interrupt levels and the interrupt sources associated with each of these interrupt levels.

Table 12. Interrupt source

| Priority level | ISR[3] | ISR[2] | ISR[1] | ISR[0] | Source of the interrupt |
|----------------|--------|--------|--------|--------|--|
| 1 | 0 | 1 | 1 | 0 | LSR (Receiver Line Status Register) |
| 2 | 0 | 1 | 0 | 0 | RXRDY (Received Data Ready) |
| 2 | 1 | 1 | 0 | 0 | RXRDY (Receive Data Time-out) |
| 3 | 0 | 0 | 1 | 0 | TXRDY (Transmitter Holding Register empty) |
| 4 | 0 | 0 | 0 | 0 | MSR (Modem Status Register) |

Table 13. Interrupt Status Register bits description

| Bit | Symbol | Description |
|-----|----------|---|
| 7:6 | ISR[7:6] | FIFOs enabled. These bits are set to a logic 0 when the FIFOs are not being used in the 16C450 mode. They are set to a logic 1 when the FIFOs are enabled in the SC16C2550B mode. logic 0 or cleared = default condition |
| 5:4 | ISR[5:4] | not used |
| 3:1 | ISR[3:1] | INT priority bits 2:0. These bits indicate the source for a pending interrupt at interrupt priority levels 1, 2 and 3 (see Table 12). logic 0 or cleared = default condition |
| 0 | ISR[0] | INT status. logic 0 = an interrupt is pending and the ISR contents may be used as a pointer to the appropriate interrupt service routine logic 1 = no interrupt pending (normal default condition) |

7.5 Line Control Register (LCR)

The Line Control Register is used to specify the asynchronous data communication format. The word length, the number of stop bits and the parity are selected by writing the appropriate bits in this register.

Table 14. Line Control Register bits description

| Bit | Symbol | Description |
|-----|----------|--|
| 7 | LCR[7] | Divisor latch enable. The internal baud rate counter latch and Enhanced Feature mode enable. logic 0 = divisor latch disabled (normal default condition) logic 1 = divisor latch enabled |
| 6 | LCR[6] | Set break. When enabled, the Break control bit causes a break condition to be transmitted (the TX output is forced to a logic 0 state). This condition exists until disabled by setting LCR[6] to a logic 0. logic 0 = no TX break condition (normal default condition) logic 1 = forces the transmitter output (TX) to a logic 0 for alerting the remote receiver to a line break condition |
| 5:3 | LCR[5:3] | Programs the parity conditions (see Table 15) |
| 2 | LCR[2] | Stop bits. The length of stop bit is specified by this bit in conjunction with the programmed word length (see Table 16). logic 0 or cleared = default condition |
| 1:0 | LCR[1:0] | Word length bits 1, 0. These two bits specify the word length to be transmitted or received (see Table 17). logic 0 or cleared = default condition |

Table 15. LCR[5:3] parity selection

| LCR[5] | LCR[4] | LCR[3] | Parity selection |
|--------|--------|--------|-------------------|
| X | X | 0 | no parity |
| X | 0 | 1 | odd parity |
| 0 | 1 | 1 | even parity |
| 0 | 0 | 1 | forced parity '1' |
| 1 | 1 | 1 | forced parity '0' |

Table 16. LCR[2] stop bit length

| LCR[2] | Word length (bits) | Stop bit length (bit times) |
|--------|--------------------|-----------------------------|
| 0 | 5, 6, 7, 8 | 1 |
| 1 | 5 | 1½ |
| 1 | 6, 7, 8 | 2 |

Table 17. LCR[1:0] word length

| LCR[1] | LCR[0] | Word length (bits) |
|--------|--------|--------------------|
| 0 | 0 | 5 |
| 0 | 1 | 6 |
| 1 | 0 | 7 |
| 1 | 1 | 8 |

7.6 Modem Control Register (MCR)

This register controls the interface with the modem or a peripheral device.

Table 18. Modem Control Register bits description

| Bit | Symbol | Description |
|-----|----------|--|
| 7:5 | MCR[7:5] | reserved; set to '0' |
| 4 | MCR[4] | <p>Loopback. Enable the local Loopback mode (diagnostics). In this mode the transmitter output (\overline{TX}) and the receiver input (\overline{RX}), \overline{CTS}, \overline{DSR}, \overline{CD} and \overline{RI} are disconnected from the SC16C2550B I/O pins. Internally the modem data and control pins are connected into a loopback data configuration (see Figure 7). In this mode, the receiver and transmitter interrupts remain fully operational. The Modem Control Interrupts are also operational, but the interrupts' sources are switched to the lower four bits of the Modem Control. Interrupts continue to be controlled by the IER register.</p> <p>logic 0 = disable Loopback mode (normal default condition)</p> <p>logic 1 = enable local Loopback mode (diagnostics)</p> |
| 3 | MCR[3] | <p>$\overline{OP2}$/INT enable</p> <p>logic 0 = forces INT (A, B) outputs to the 3-state mode and sets $\overline{OP2}$ to a logic 1 (normal default condition)</p> <p>logic 1 = forces the INT (A, B) outputs to the active mode and sets $\overline{OP2}$ to a logic 0</p> |
| 2 | MCR[2] | <p>($\overline{OP1}$). $\overline{OP1A}/\overline{OP1B}$ are not available as an external signal in the SC16C2550B. This bit is instead used in the Loopback mode only. In the Loopback mode, this bit is used to write the state of the modem \overline{RI} interface signal.</p> |
| 1 | MCR[1] | <p>\overline{RTS}</p> <p>logic 0 = force \overline{RTS} output to a logic 1 (normal default condition)</p> <p>logic 1 = force \overline{RTS} output to a logic 0</p> |
| 0 | MCR[0] | <p>\overline{DTR}</p> <p>logic 0 = force \overline{DTR} output to a logic 1 (normal default condition)</p> <p>logic 1 = force \overline{DTR} output to a logic 0</p> |

7.7 Line Status Register (LSR)

This register provides the status of data transfers between the SC16C2550B and the CPU.

Table 19. Line Status Register bits description

| Bit | Symbol | Description |
|-----|--------|---|
| 7 | LSR[7] | FIFO data error. logic 0 = no error (normal default condition) logic 1 = at least one parity error, framing error or break indication is in the current FIFO data. This bit is cleared when there are no remaining error flags associated with the remaining data in the FIFO. |
| 6 | LSR[6] | THR and TSR empty. This bit is the Transmit Empty indicator. This bit is set to a logic 1 whenever the Transmit Holding Register and the Transmit Shift Register are both empty. It is reset to logic 0 whenever either the THR or TSR contains a data character. In the FIFO mode, this bit is set to '1' whenever the Transmit FIFO and Transmit Shift Register are both empty. |
| 5 | LSR[5] | THR empty. This bit is the Transmit Holding Register Empty indicator. This bit indicates that the UART is ready to accept a new character for transmission. In addition, this bit causes the UART to issue an interrupt to CPU when the THR interrupt enable is set. The THR bit is set to a logic 1 when a character is transferred from the transmit holding register into the transmitter shift register. The bit is reset to a logic 0 concurrently with the loading of the transmitter holding register by the CPU. In the FIFO mode, this bit is set when the transmit FIFO is empty; it is cleared when at least 1 byte is written to the transmit FIFO. |
| 4 | LSR[4] | Break interrupt. logic 0 = no break condition (normal default condition) logic 1 = the receiver received a break signal (RX was a logic 0 for one character frame time). In the FIFO mode, only one break character is loaded into the FIFO. |
| 3 | LSR[3] | Framing error. logic 0 = no framing error (normal default condition) logic 1 = framing error. The receive character did not have a valid stop bit(s). In the FIFO mode, this error is associated with the character at the top of the FIFO. |
| 2 | LSR[2] | Parity error. logic 0 = no parity error (normal default condition) logic 1 = parity error. The receive character does not have correct parity information and is suspect. In the FIFO mode, this error is associated with the character at the top of the FIFO. |
| 1 | LSR[1] | Overrun error. logic 0 = no overrun error (normal default condition) logic 1 = overrun error. A data overrun error occurred in the Receive Shift Register. This happens when additional data arrives while the FIFO is full. In this case, the previous data in the shift register is overwritten. Note that under this condition, the data byte in the Receive Shift Register is not transferred into the FIFO, therefore the data in the FIFO is not corrupted by the error. |

Table 19. Line Status Register bits description ...continued

| Bit | Symbol | Description |
|-----|--------|--|
| 0 | LSR[0] | Receive data ready. logic 0 = no data in Receive Holding Register or FIFO (normal default condition) logic 1 = data has been received and is saved in the Receive Holding Register or FIFO |

7.8 Modem Status Register (MSR)

This register provides the current state of the control interface signals from the modem or other peripheral device to which the SC16C2550B is connected. Four bits of this register are used to indicate the changed information. These bits are set to a logic 1 whenever a control input from the modem changes state. These bits are set to a logic 0 whenever the CPU reads this register.

Table 20. Modem Status Register bits description

| Bit | Symbol | Description |
|-----|--------|--|
| 7 | MSR[7] | CD. During normal operation, this bit is the complement of the \overline{CD} input. Reading this bit in the Loopback mode produces the state of MCR[3] ($\overline{OP2}$). |
| 6 | MSR[6] | RI. During normal operation, this bit is the complement of the \overline{RI} input. Reading this bit in the Loopback mode produces the state of MCR[2] ($\overline{OP1}$). |
| 5 | MSR[5] | DSR. During normal operation, this bit is the complement of the \overline{DSR} input. During the Loopback mode, this bit is equivalent to MCR[0] (\overline{DTR}). |
| 4 | MSR[4] | CTS. During normal operation, this bit is the complement of the \overline{CTS} input. During the Loopback mode, this bit is equivalent to MCR[1] (\overline{RTS}). |
| 3 | MSR[3] | $\Delta\overline{CD}$ [1] logic 0 = no \overline{CD} change (normal default condition) logic 1 = the \overline{CD} input to the SC16C2550B has changed state since the last time it was read. A modem Status Interrupt will be generated. |
| 2 | MSR[2] | $\Delta\overline{RI}$ [1] logic 0 = no \overline{RI} change (normal default condition) logic 1 = the \overline{RI} input to the SC16C2550B has changed from a logic 0 to a logic 1. A modem Status Interrupt will be generated. |
| 1 | MSR[1] | $\Delta\overline{DSR}$ [1] logic 0 = no \overline{DSR} change (normal default condition) logic 1 = the \overline{DSR} input to the SC16C2550B has changed state since the last time it was read. A modem Status Interrupt will be generated. |
| 0 | MSR[0] | $\Delta\overline{CTS}$ [1] logic 0 = no \overline{CTS} change (normal default condition) logic 1 = the \overline{CTS} input to the SC16C2550B has changed state since the last time it was read. A modem Status Interrupt will be generated. |

[1] Whenever any MSR bit 3:0 is set to logic 1, a Modem Status Interrupt will be generated.

7.9 Scratchpad Register (SPR)

The SC16C2550B provides a temporary data register to store 8 bits of user information.

7.10 SC16C2550B external reset condition

Table 21. Reset state for registers

| Register | Reset state |
|----------|--|
| IER | IER[7:0] = 0 |
| FCR | FCR[7:0] = 0 |
| ISR | ISR[7:1] = 0; ISR[0] = 1 |
| LCR | LCR[7:0] = 0 |
| MCR | MCR[7:0] = 0 |
| LSR | LSR[7] = 0; LSR[6:5] = 1; LSR[4:0] = 0 |
| MSR | MSR[7:4] = input signals; MSR[3:0] = 0 |
| SPR | SFR[7:0] = 1 |
| DLL | DLL[7:0] = X |
| DLM | DLM[7:0] = X |

Table 22. Reset state for outputs

| Output | Reset state |
|---|-------------------|
| TXA, TXB | logic 1 |
| $\overline{\text{OP2A}}$, $\overline{\text{OP2B}}$ | logic 1 |
| $\overline{\text{RTSA}}$, $\overline{\text{RTSB}}$ | logic 1 |
| $\overline{\text{DTRA}}$, $\overline{\text{DTRB}}$ | logic 1 |
| INTA, INTB | 3-state condition |

8. Limiting values

Table 23. Limiting values

In accordance with the Absolute Maximum Rating System (IEC 60134).

| Symbol | Parameter | Conditions | Min | Max | Unit |
|-----------------------|-------------------------------------|--------------------|-----------|-----------------------|------|
| V _{CC} | supply voltage | | - | 7 | V |
| V _n | voltage on any other pin | at D7 to D0 pins | GND – 0.3 | V _{CC} + 0.3 | V |
| | | at input only pins | GND – 0.3 | 5.3 | V |
| T _{amb} | operating temperature | | –40 | +85 | °C |
| T _{stg} | storage temperature | | –65 | +150 | °C |
| P _{tot/pack} | total power dissipation per package | | - | 500 | mW |

9. Static characteristics

Table 24. Static characteristics

T_{amb} = –40 °C to +85 °C; tolerance of V_{CC} ± 10 %; unless otherwise specified.

| Symbol | Parameter | Conditions | V _{CC} = 2.5 V | | V _{CC} = 3.3 V | | V _{CC} = 5.0 V | | Unit |
|----------------------|---------------------------------|---|-------------------------|-----------------|-------------------------|-----------------|-------------------------|-----------------|------|
| | | | Min | Max | Min | Max | Min | Max | |
| V _{IL(clk)} | clock LOW-level input voltage | | –0.3 | +0.45 | –0.3 | +0.6 | –0.5 | +0.6 | V |
| V _{IH(clk)} | clock HIGH-level input voltage | | 1.8 | V _{CC} | 2.4 | V _{CC} | 3.0 | V _{CC} | V |
| V _{IL} | LOW-level input voltage | except X1 clock | –0.3 | +0.65 | –0.3 | +0.8 | –0.5 | +0.8 | V |
| V _{IH} | HIGH-level input voltage | except X1 clock | 1.6 | - | 2.0 | - | 2.2 | - | V |
| V _{OL} | LOW-level output voltage | on all outputs ^[1] | | | | | | | |
| | | I _{OL} = 5 mA (data bus) | - | - | - | - | - | 0.4 | V |
| | | I _{OL} = 4 mA (other outputs) | - | - | - | 0.4 | - | - | V |
| | | I _{OL} = 2 mA (data bus) | - | 0.4 | - | - | - | - | V |
| V _{OH} | HIGH-level output voltage | I _{OH} = 1.6 mA (other outputs) | - | 0.4 | - | - | - | - | V |
| | | I _{OH} = –5 mA (data bus) | - | - | - | - | 2.4 | - | V |
| | | I _{OH} = –1 mA (other outputs) | - | - | 2.0 | - | - | - | V |
| | | I _{OH} = –800 μA (data bus) | 1.85 | - | - | - | - | - | V |
| | | I _{OH} = –400 μA (other outputs) | 1.85 | - | - | - | - | - | V |
| I _{LIL} | LOW-level input leakage current | | - | ±10 | - | ±10 | - | ±10 | μA |
| I _{L(clk)} | clock leakage current | | - | ±30 | - | ±30 | - | ±30 | μA |
| I _{CC} | supply current | f = 5 MHz | - | 3.5 | - | 4.5 | - | 4.5 | mA |
| C _i | input capacitance | | - | 5 | - | 5 | - | 5 | pF |

[1] Except XTAL2, V_{OL} = 1 V typical.

10. Dynamic characteristics

Table 25. Dynamic characteristics

$T_{amb} = -40\text{ }^{\circ}\text{C}$ to $+85\text{ }^{\circ}\text{C}$; tolerance of $V_{CC} \pm 10\%$; unless otherwise specified.

| Symbol | Parameter | Conditions | $V_{CC} = 2.5\text{ V}$ | | $V_{CC} = 3.3\text{ V}$ | | $V_{CC} = 5.0\text{ V}$ | | Unit |
|------------|---|------------|-------------------------|--------------|-------------------------|--------------|-------------------------|--------------|------|
| | | | Min | Max | Min | Max | Min | Max | |
| t_{w1} | clock pulse duration | | 10 | - | 6 | - | 6 | - | ns |
| t_{w2} | clock pulse duration | | 10 | - | 6 | - | 6 | - | ns |
| f_{XTAL} | oscillator/clock frequency | [1][2] | - | 48 | - | 80 | - | 80 | MHz |
| t_{6s} | address set-up time | | 0 | - | 0 | - | 0 | - | ns |
| t_{6h} | address hold time | | 0 | - | 0 | - | 0 | - | ns |
| t_{7d} | $\overline{\text{IOR}}$ delay from chip select | | 10 | - | 10 | - | 10 | - | ns |
| t_{7w} | $\overline{\text{IOR}}$ strobe width | 25 pF load | 77 | - | 26 | - | 23 | - | ns |
| t_{7h} | chip select hold time from $\overline{\text{IOR}}$ | | 0 | - | 0 | - | 0 | - | ns |
| t_{9d} | read cycle delay | 25 pF load | 20 | - | 20 | - | 20 | - | ns |
| t_{12d} | delay from $\overline{\text{IOR}}$ to data | 25 pF load | - | 77 | - | 26 | - | 23 | ns |
| t_{12h} | data disable time | 25 pF load | - | 15 | - | 15 | - | 15 | ns |
| t_{13d} | $\overline{\text{IOW}}$ delay from chip select | | 10 | - | 10 | - | 10 | - | ns |
| t_{13w} | $\overline{\text{IOW}}$ strobe width | | 20 | - | 20 | - | 15 | - | ns |
| t_{13h} | chip select hold time from $\overline{\text{IOW}}$ | | 0 | - | 0 | - | 0 | - | ns |
| t_{15d} | write cycle delay | | 25 | - | 25 | - | 20 | - | ns |
| t_{16s} | data set-up time | | 20 | - | 20 | - | 15 | - | ns |
| t_{16h} | data hold time | | 15 | - | 5 | - | 5 | - | ns |
| t_{17d} | delay from $\overline{\text{IOW}}$ to output | 25 pF load | - | 100 | - | 33 | - | 29 | ns |
| t_{18d} | delay to set interrupt from Modem input | 25 pF load | - | 100 | - | 24 | - | 23 | ns |
| t_{19d} | delay to reset interrupt from $\overline{\text{IOR}}$ | 25 pF load | - | 100 | - | 24 | - | 23 | ns |
| t_{20d} | delay from stop to set interrupt | [3] | - | T_{RCLK} | - | T_{RCLK} | - | T_{RCLK} | s |
| t_{21d} | delay from $\overline{\text{IOR}}$ to reset interrupt | 25 pF load | - | 100 | - | 29 | - | 28 | ns |
| t_{22d} | delay from start to set interrupt | | - | 100 | - | 45 | - | 40 | ns |
| t_{23d} | delay from $\overline{\text{IOW}}$ to transmit start | [3] | $8T_{RCLK}$ | $24T_{RCLK}$ | $8T_{RCLK}$ | $24T_{RCLK}$ | $8T_{RCLK}$ | $24T_{RCLK}$ | s |
| t_{24d} | delay from $\overline{\text{IOW}}$ to reset interrupt | | - | 100 | - | 45 | - | 40 | ns |
| t_{25d} | delay from stop to set $\overline{\text{RXRDY}}$ | [3] | - | T_{RCLK} | - | T_{RCLK} | - | T_{RCLK} | s |
| t_{26d} | delay from $\overline{\text{IOR}}$ to reset $\overline{\text{RXRDY}}$ | | - | 100 | - | 45 | - | 40 | ns |
| t_{27d} | delay from $\overline{\text{IOW}}$ to set $\overline{\text{TXRDY}}$ | | - | 100 | - | 45 | - | 40 | ns |

Table 25. Dynamic characteristics ...continued

$T_{amb} = -40^{\circ}\text{C}$ to $+85^{\circ}\text{C}$; tolerance of $V_{CC} \pm 10\%$; unless otherwise specified.

| Symbol | Parameter | Conditions | $V_{CC} = 2.5\text{ V}$ | | $V_{CC} = 3.3\text{ V}$ | | $V_{CC} = 5.0\text{ V}$ | | Unit |
|-------------|------------------------------------|------------|-------------------------|----------------|-------------------------|----------------|-------------------------|----------------|------|
| | | | Min | Max | Min | Max | Min | Max | |
| t_{28d} | delay from start to reset TXRDY | [3] | - | $8T_{RCLK}$ | - | $8T_{RCLK}$ | - | $8T_{RCLK}$ | s |
| t_{RESET} | RESET pulse width | [4] | 200 | - | 40 | - | 40 | - | ns |
| N | baud rate divisor | | 1 | $(2^{16} - 1)$ | 1 | $(2^{16} - 1)$ | 1 | $(2^{16} - 1)$ | |

[1] Applies to external clock, crystal oscillator max 24 MHz.

[2] Maximum frequency = $\frac{1}{t_{w3}}$

[3] RCLK is an internal signal derived from divisor latch LSB (DLL) and divisor latch MSB (DLM) divisor latches.

[4] Reset pulse must happen when these signals are inactive: \overline{CS} , \overline{IOW} , \overline{IOR} .

10.1 Timing diagrams

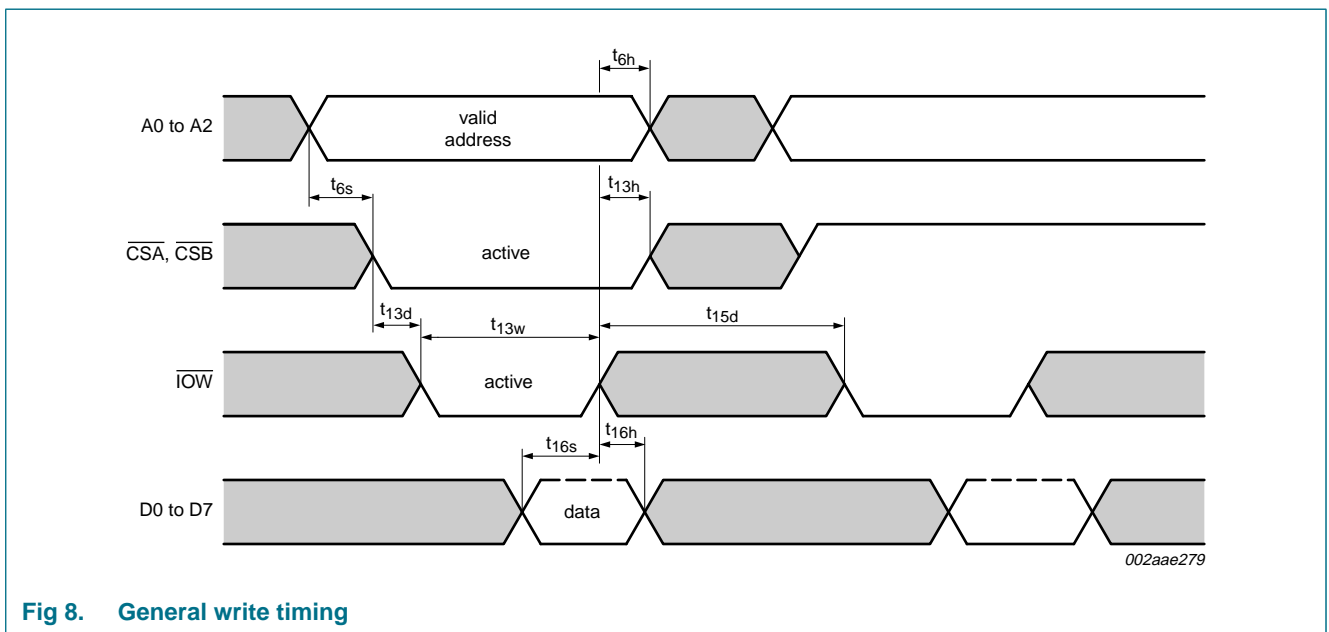

Fig 8. General write timing

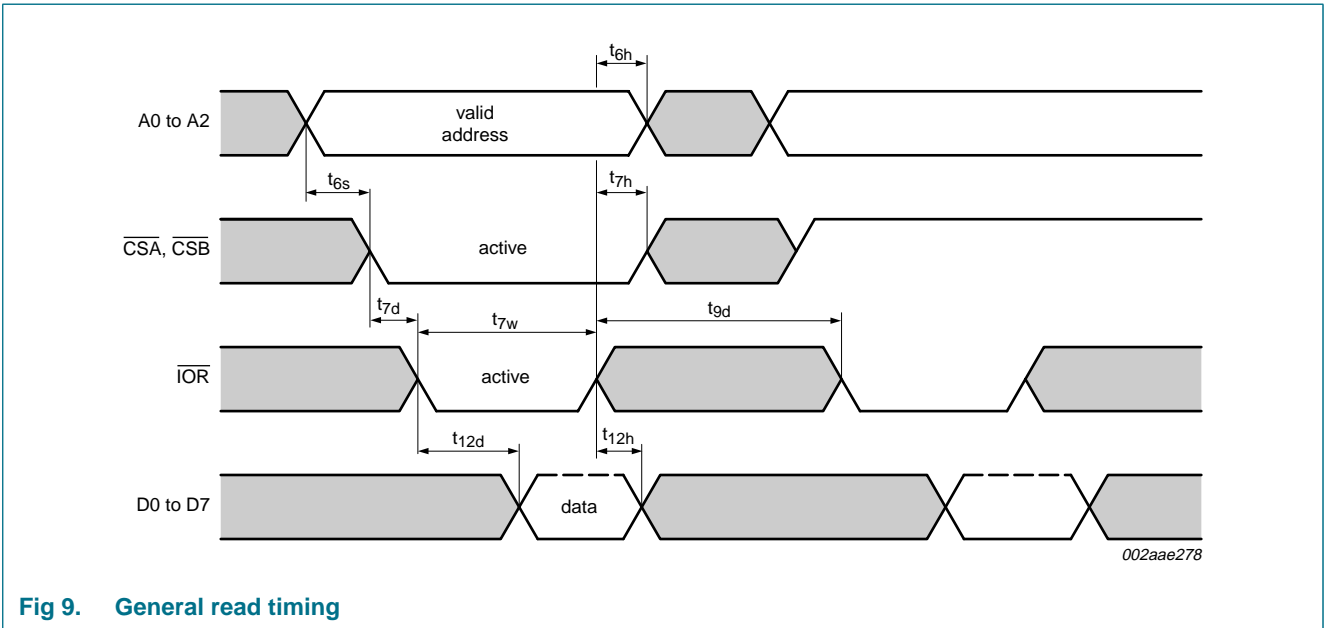

Fig 9. General read timing

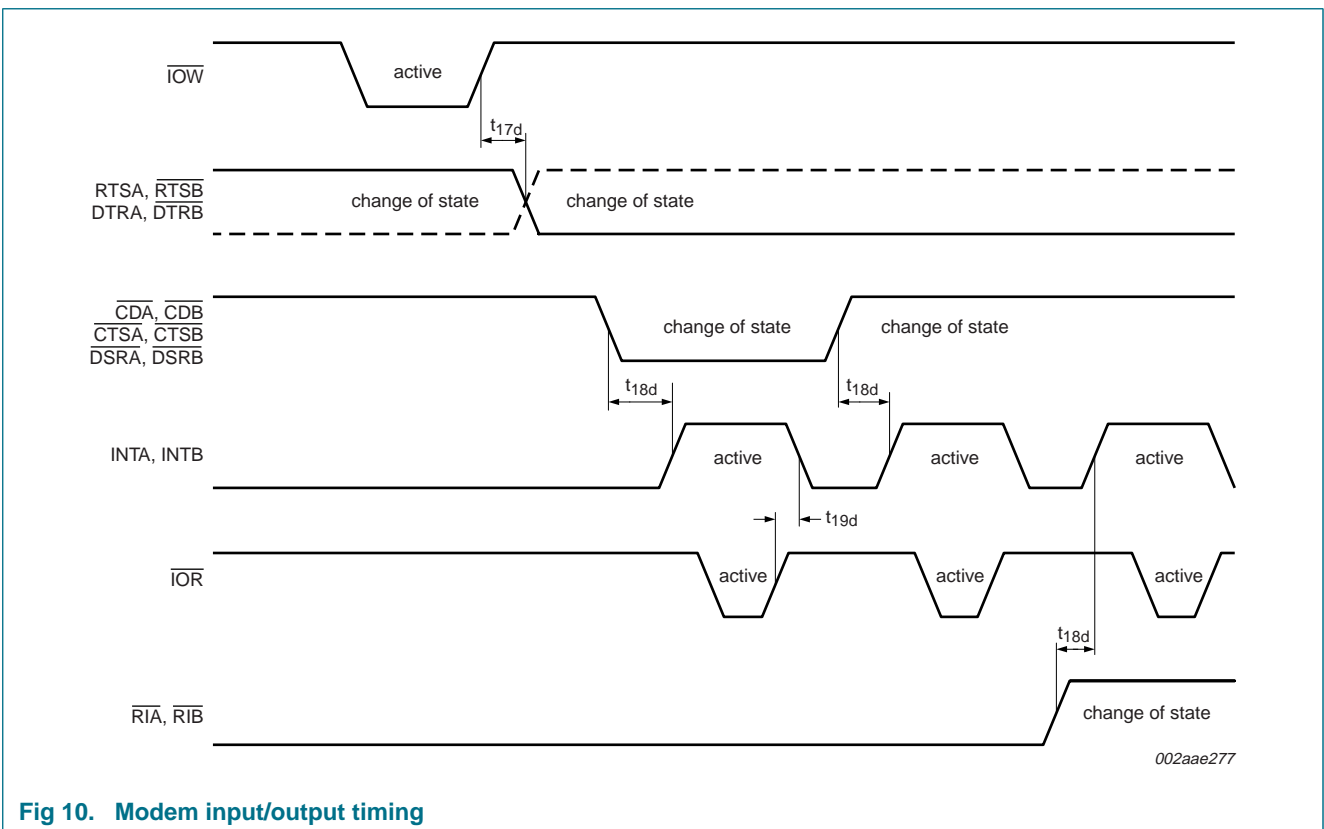

Fig 10. Modem input/output timing

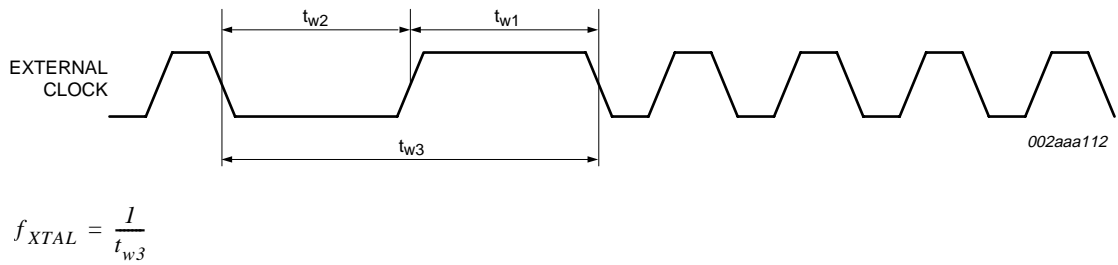

Fig 11. External clock timing

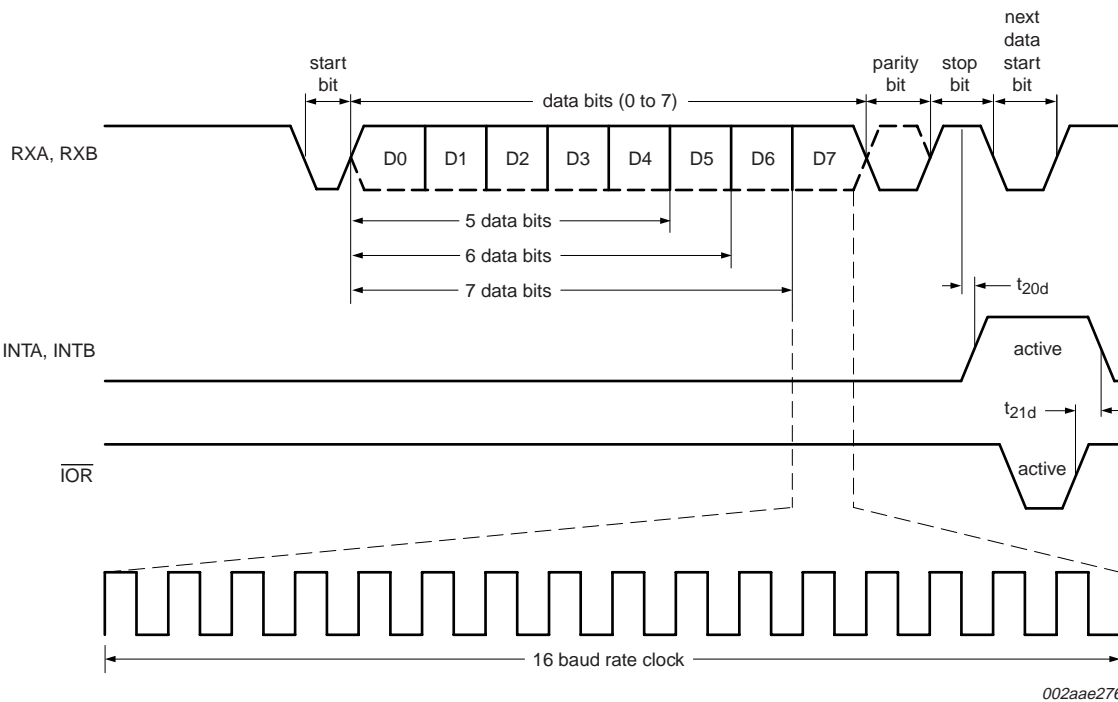

Fig 12. Receive timing

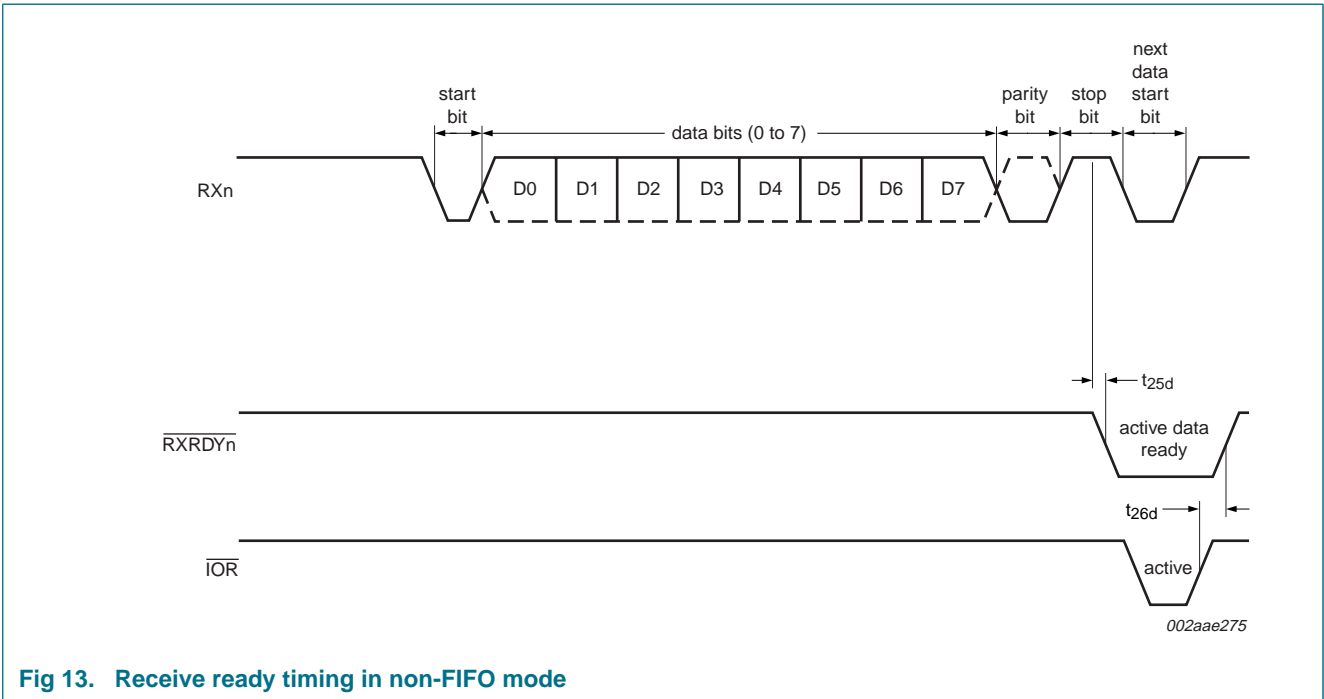

Fig 13. Receive ready timing in non-FIFO mode

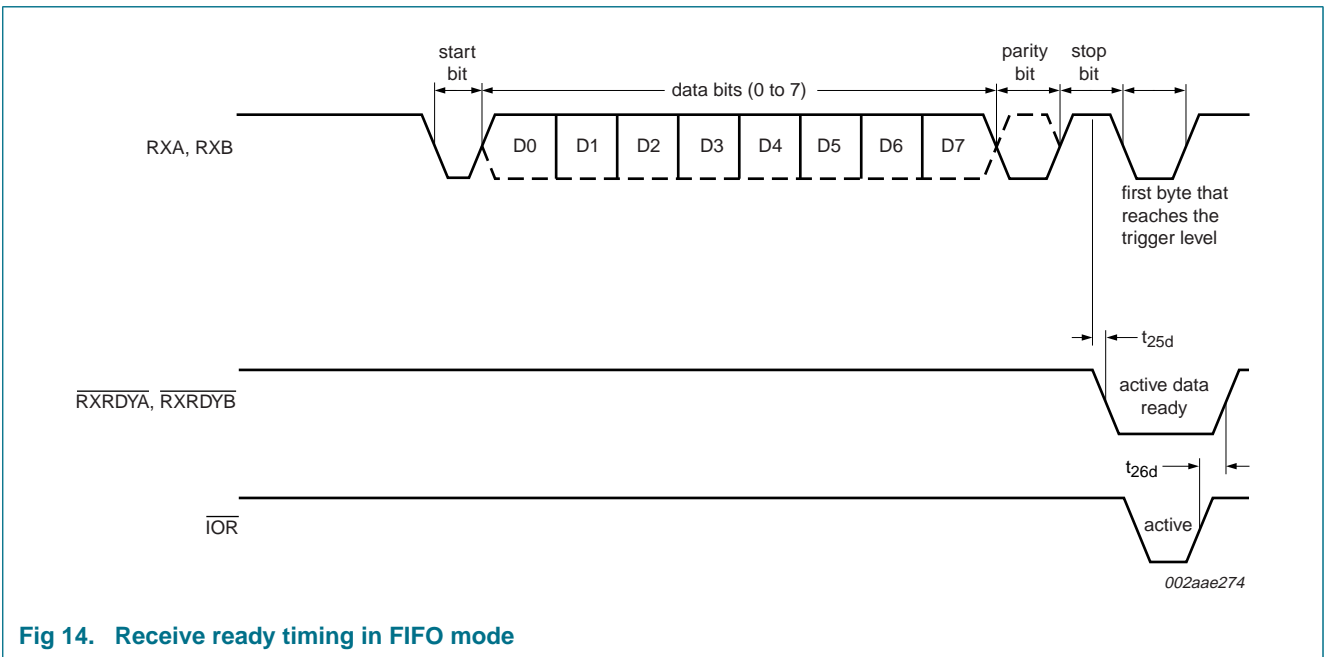

Fig 14. Receive ready timing in FIFO mode

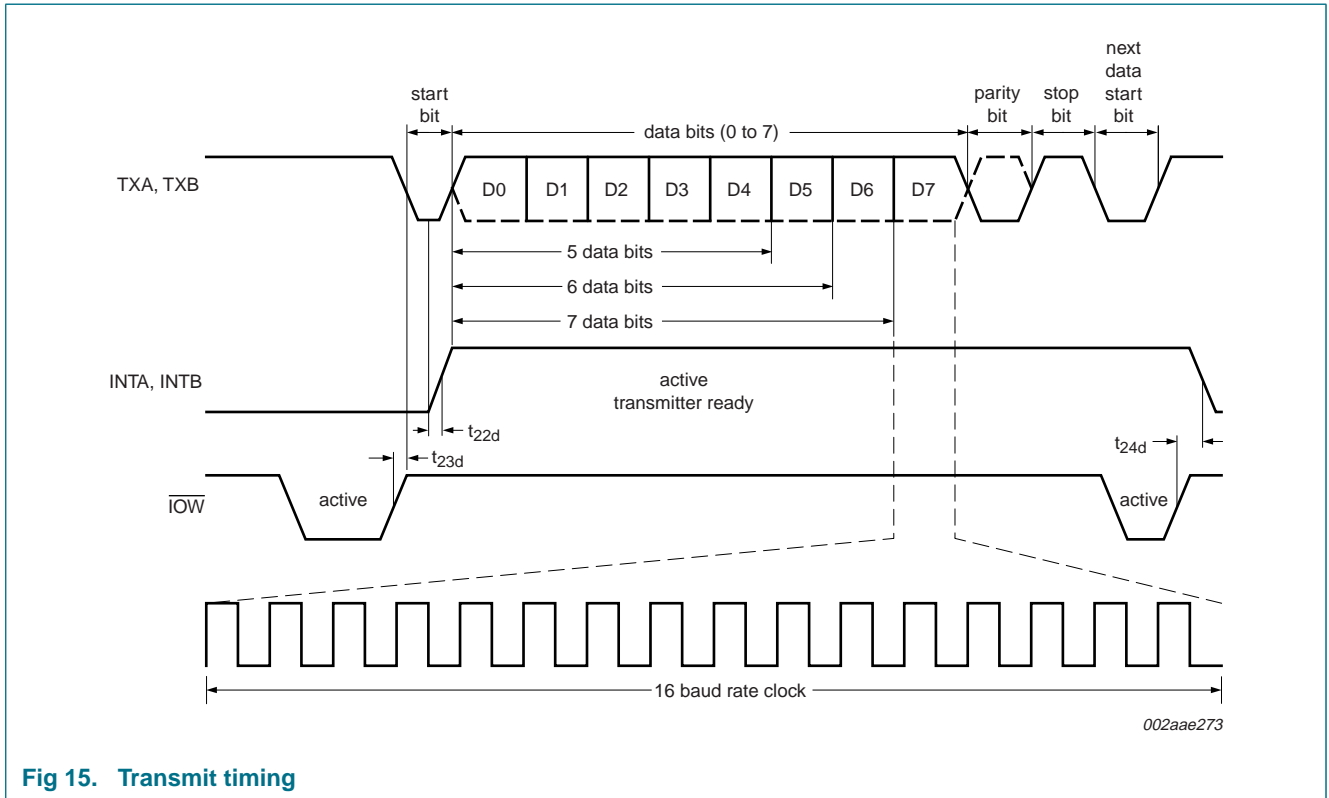

Fig 15. Transmit timing

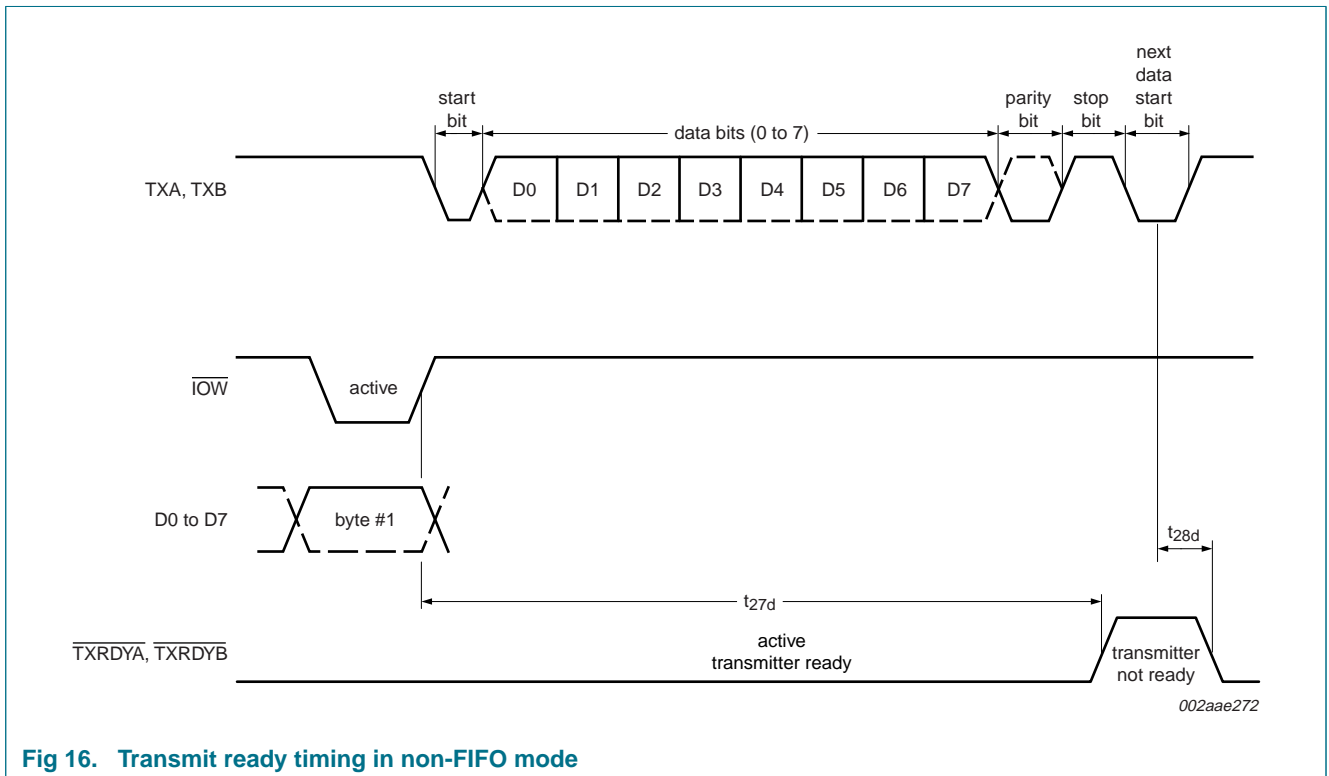

Fig 16. Transmit ready timing in non-FIFO mode

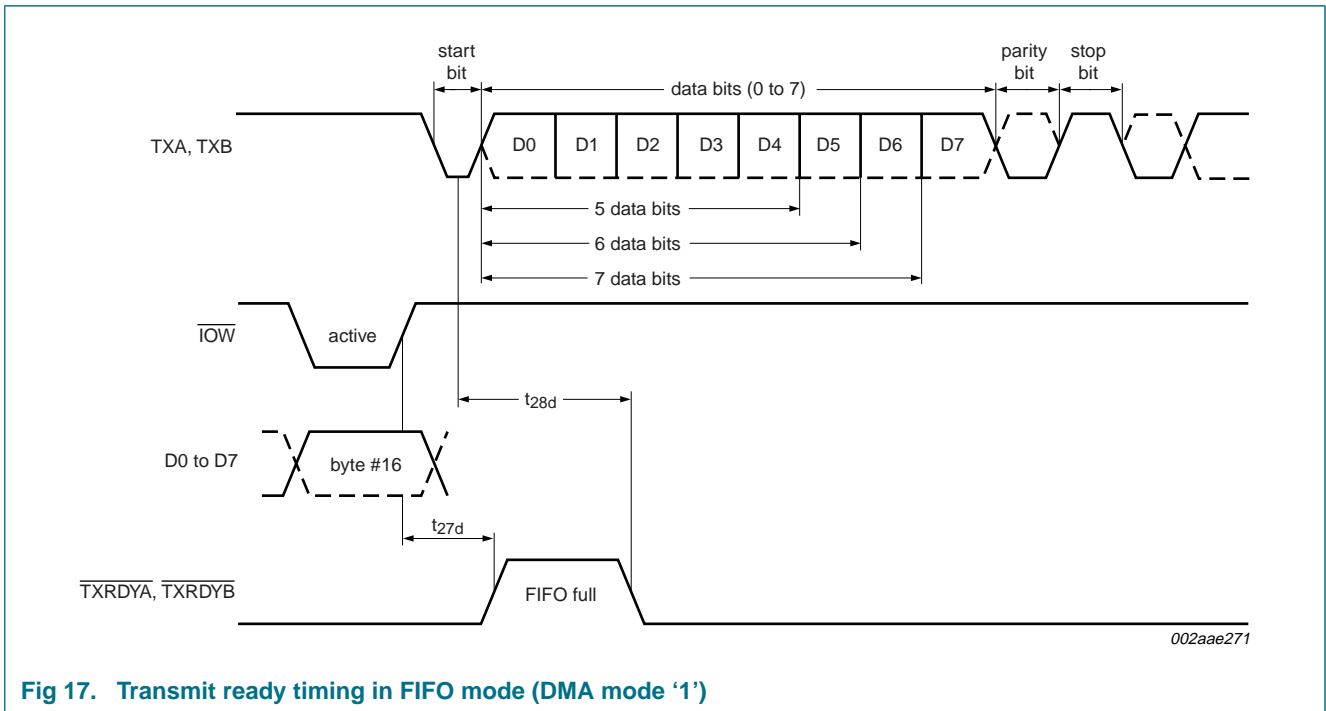

Fig 17. Transmit ready timing in FIFO mode (DMA mode '1')

11. Package outline

PLCC44: plastic leaded chip carrier; 44 leads

SOT187-2

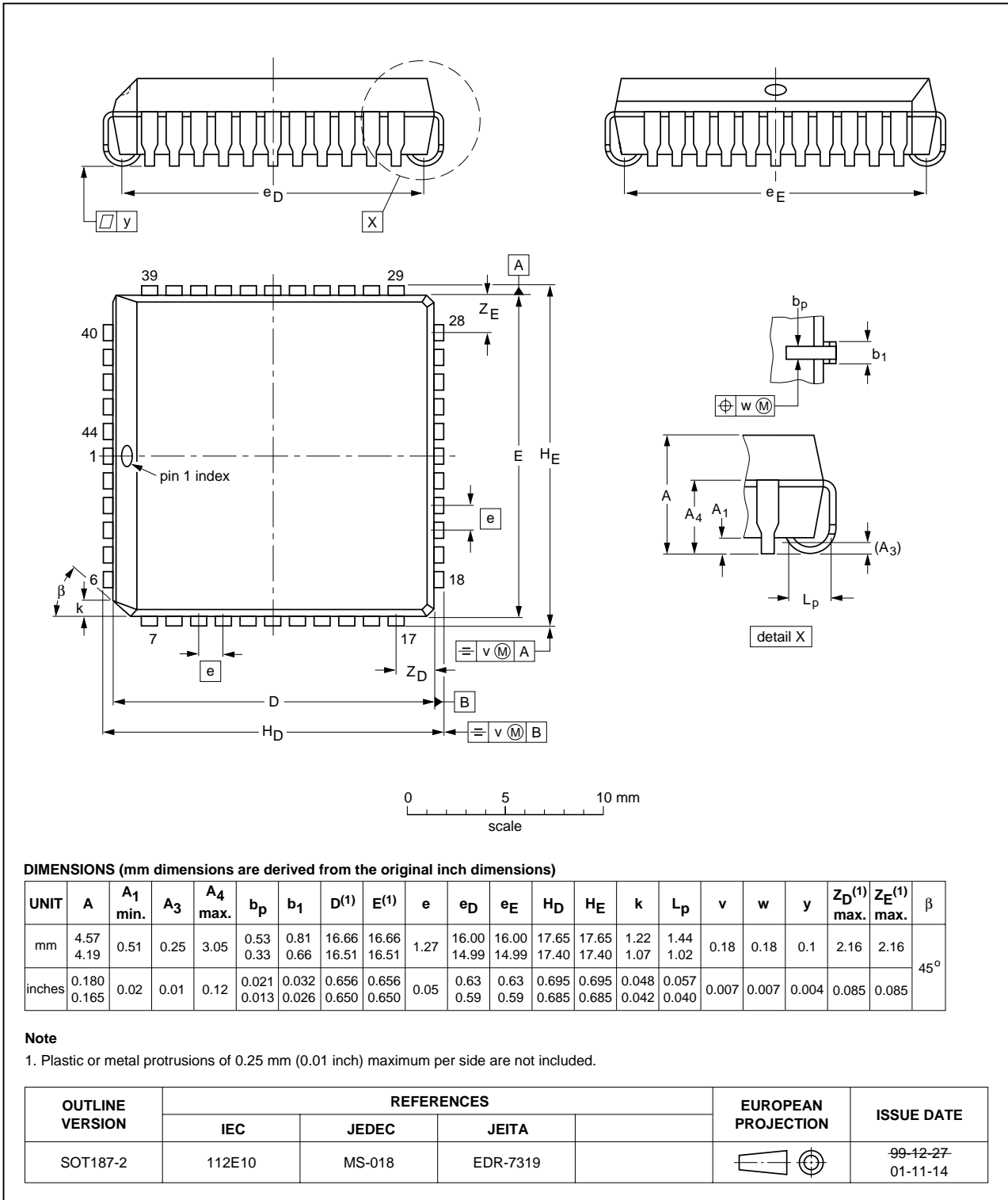
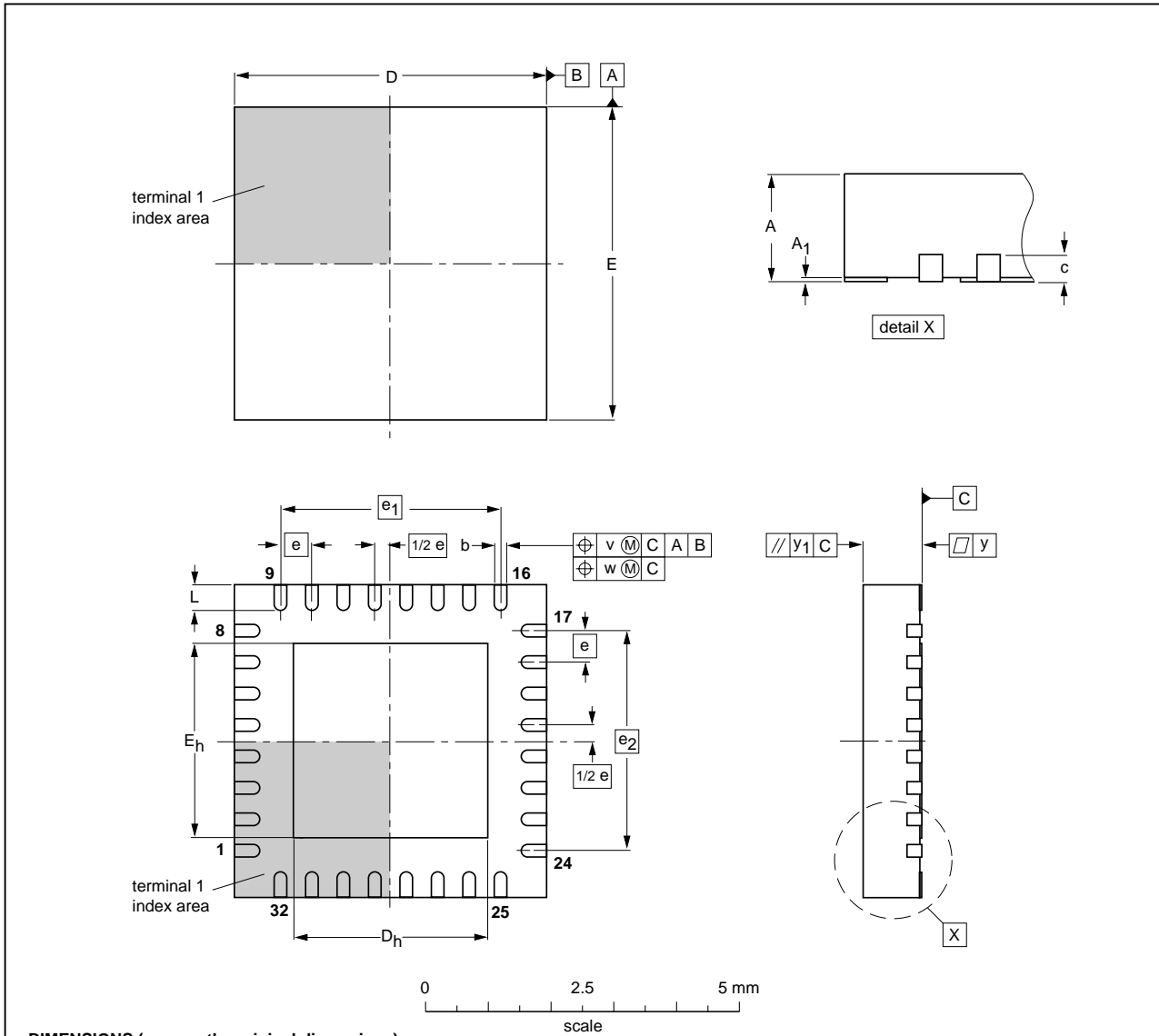

Fig 18. Package outline SOT187-2 (PLCC44)

HVQFN32: plastic thermal enhanced very thin quad flat package; no leads; 32 terminals; body 5 x 5 x 0.85 mm

SOT617-1



DIMENSIONS (mm are the original dimensions)

| UNIT | A ⁽¹⁾ max. | A ₁ | b | c | D ⁽¹⁾ | D _h | E ⁽¹⁾ | E _h | e | e ₁ | e ₂ | L | v | w | y | y ₁ |
|------|--------------------------|----------------|--------------|-----|------------------|----------------|------------------|----------------|-----|----------------|----------------|------------|-----|------|------|----------------|
| mm | 1 | 0.05 0.00 | 0.30 0.18 | 0.2 | 5.1 4.9 | 3.25 2.95 | 5.1 4.9 | 3.25 2.95 | 0.5 | 3.5 | 3.5 | 0.5 0.3 | 0.1 | 0.05 | 0.05 | 0.1 |

Note

1. Plastic or metal protrusions of 0.075 mm maximum per side are not included.

| OUTLINE VERSION | REFERENCES | | | | EUROPEAN PROJECTION | ISSUE DATE |
|--------------------|------------|--------|-------|--|------------------------|----------------------|
| | IEC | JEDEC | JEITA | | | |
| SOT617-1 | --- | MO-220 | --- | | | 01-08-08 02-10-18 |

Fig 19. Package outline SOT617-1 (HVQFN32)

LQFP48: plastic low profile quad flat package; 48 leads; body 7 x 7 x 1.4 mm

SOT313-2

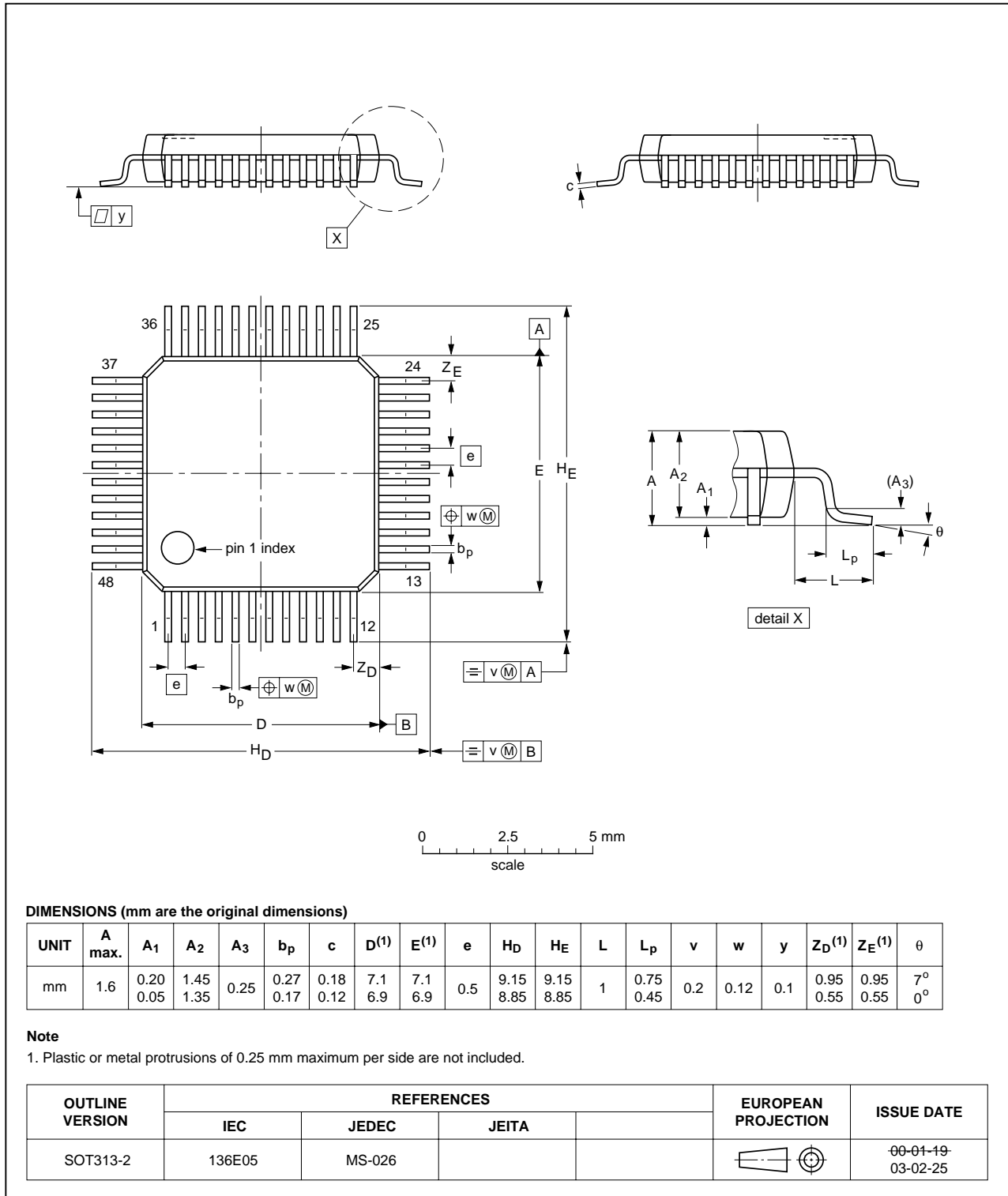

Fig 20. Package outline SOT313-2 (LQFP48)

DIP40: plastic dual in-line package; 40 leads (600 mil)

SOT129-1

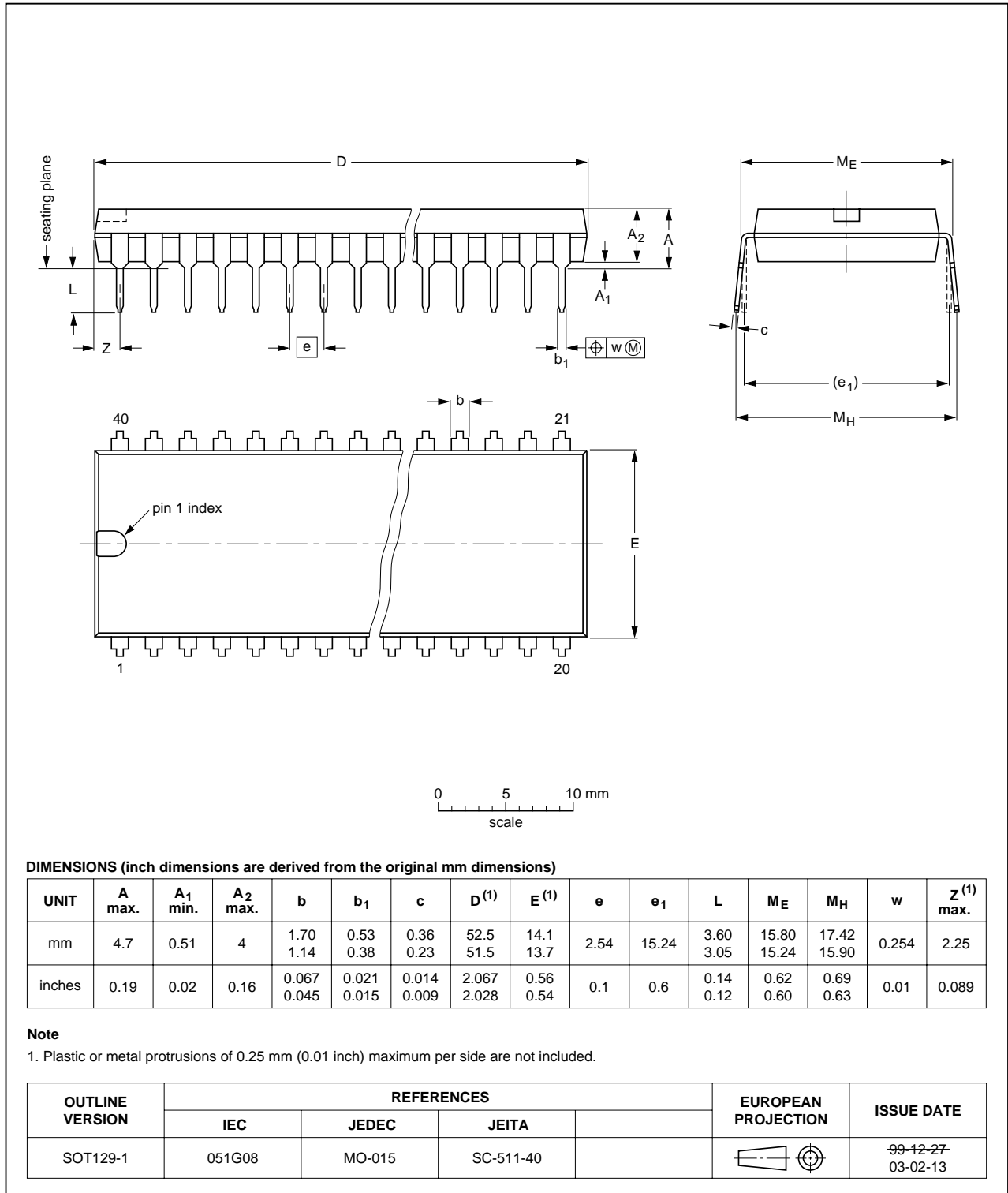

Fig 21. Package outline SOT129-1 (DIP40)

12. Soldering of SMD packages

This text provides a very brief insight into a complex technology. A more in-depth account of soldering ICs can be found in Application Note *AN10365 "Surface mount reflow soldering description"*.

12.1 Introduction to soldering

Soldering is one of the most common methods through which packages are attached to Printed Circuit Boards (PCBs), to form electrical circuits. The soldered joint provides both the mechanical and the electrical connection. There is no single soldering method that is ideal for all IC packages. Wave soldering is often preferred when through-hole and Surface Mount Devices (SMDs) are mixed on one printed wiring board; however, it is not suitable for fine pitch SMDs. Reflow soldering is ideal for the small pitches and high densities that come with increased miniaturization.

12.2 Wave and reflow soldering

Wave soldering is a joining technology in which the joints are made by solder coming from a standing wave of liquid solder. The wave soldering process is suitable for the following:

- Through-hole components
- Leaded or leadless SMDs, which are glued to the surface of the printed circuit board

Not all SMDs can be wave soldered. Packages with solder balls, and some leadless packages which have solder lands underneath the body, cannot be wave soldered. Also, leaded SMDs with leads having a pitch smaller than ~0.6 mm cannot be wave soldered, due to an increased probability of bridging.

The reflow soldering process involves applying solder paste to a board, followed by component placement and exposure to a temperature profile. Leaded packages, packages with solder balls, and leadless packages are all reflow solderable.

Key characteristics in both wave and reflow soldering are:

- Board specifications, including the board finish, solder masks and vias
- Package footprints, including solder thieves and orientation
- The moisture sensitivity level of the packages
- Package placement
- Inspection and repair
- Lead-free soldering versus SnPb soldering

12.3 Wave soldering

Key characteristics in wave soldering are:

- Process issues, such as application of adhesive and flux, clinching of leads, board transport, the solder wave parameters, and the time during which components are exposed to the wave
- Solder bath specifications, including temperature and impurities

12.4 Reflow soldering

Key characteristics in reflow soldering are:

- Lead-free versus SnPb soldering; note that a lead-free reflow process usually leads to higher minimum peak temperatures (see [Figure 22](#)) than a SnPb process, thus reducing the process window
- Solder paste printing issues including smearing, release, and adjusting the process window for a mix of large and small components on one board
- Reflow temperature profile; this profile includes preheat, reflow (in which the board is heated to the peak temperature) and cooling down. It is imperative that the peak temperature is high enough for the solder to make reliable solder joints (a solder paste characteristic). In addition, the peak temperature must be low enough that the packages and/or boards are not damaged. The peak temperature of the package depends on package thickness and volume and is classified in accordance with [Table 26](#) and [27](#)

Table 26. SnPb eutectic process (from J-STD-020C)

| Package thickness (mm) | Package reflow temperature (°C) | |
|------------------------|---------------------------------|-------|
| | Volume (mm ³) | |
| | < 350 | ≥ 350 |
| < 2.5 | 235 | 220 |
| ≥ 2.5 | 220 | 220 |

Table 27. Lead-free process (from J-STD-020C)

| Package thickness (mm) | Package reflow temperature (°C) | | |
|------------------------|---------------------------------|-------------|--------|
| | Volume (mm ³) | | |
| | < 350 | 350 to 2000 | > 2000 |
| < 1.6 | 260 | 260 | 260 |
| 1.6 to 2.5 | 260 | 250 | 245 |
| > 2.5 | 250 | 245 | 245 |

Moisture sensitivity precautions, as indicated on the packing, must be respected at all times.

Studies have shown that small packages reach higher temperatures during reflow soldering, see [Figure 22](#).

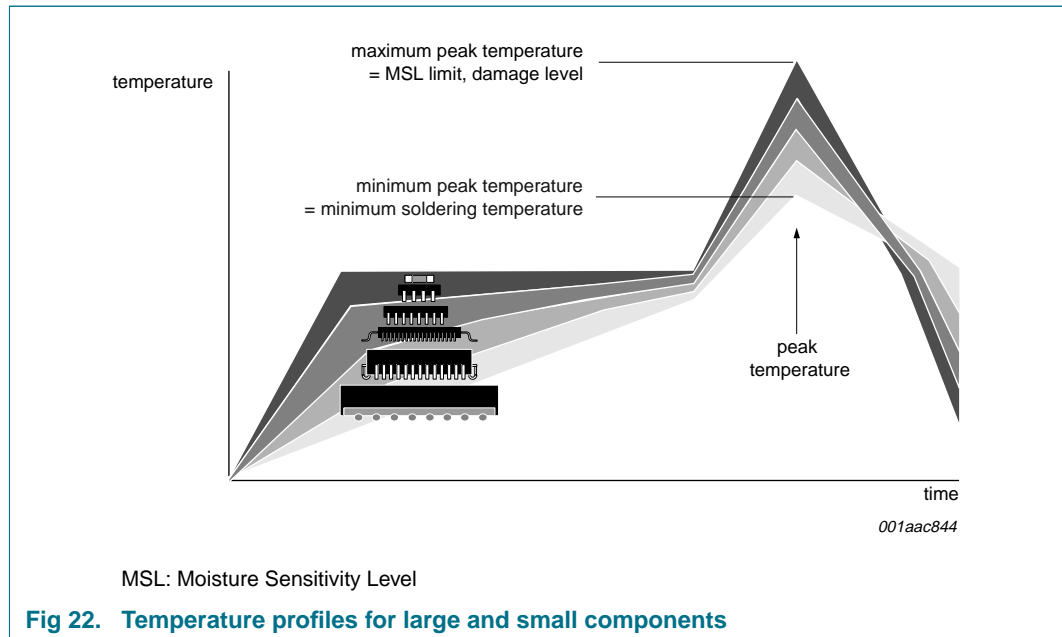

For further information on temperature profiles, refer to Application Note *AN10365* "Surface mount reflow soldering description".

13. Soldering of through-hole mount packages

13.1 Introduction to soldering through-hole mount packages

This text gives a very brief insight into wave, dip and manual soldering.

Wave soldering is the preferred method for mounting of through-hole mount IC packages on a printed-circuit board.

13.2 Soldering by dipping or by solder wave

Driven by legislation and environmental forces the worldwide use of lead-free solder pastes is increasing. Typical dwell time of the leads in the wave ranges from 3 seconds to 4 seconds at 250 °C or 265 °C, depending on solder material applied, SnPb or Pb-free respectively.

The total contact time of successive solder waves must not exceed 5 seconds.

The device may be mounted up to the seating plane, but the temperature of the plastic body must not exceed the specified maximum storage temperature ($T_{stg(max)}$). If the printed-circuit board has been pre-heated, forced cooling may be necessary immediately after soldering to keep the temperature within the permissible limit.

13.3 Manual soldering

Apply the soldering iron (24 V or less) to the lead(s) of the package, either below the seating plane or not more than 2 mm above it. If the temperature of the soldering iron bit is less than 300 °C it may remain in contact for up to 10 seconds. If the bit temperature is between 300 °C and 400 °C, contact may be up to 5 seconds.

13.4 Package related soldering information

Table 28. Suitability of through-hole mount IC packages for dipping and wave soldering

| Package | Soldering method | |
|---------------------------------|------------------|-------------------------|
| | Dipping | Wave |
| CPGA, HCPGA | - | suitable |
| DBS, DIP, HDIP, RDBS, SDIP, SIL | suitable | suitable ^[1] |
| PMFP ^[2] | - | not suitable |

[1] For SDIP packages, the longitudinal axis must be parallel to the transport direction of the printed-circuit board.

[2] For PMFP packages hot bar soldering or manual soldering is suitable.

14. Abbreviations

Table 29. Abbreviations

| Acronym | Description |
|---------|---|
| CPU | Central Processing Unit |
| DLL | Divisor Latch LSB |
| DLM | Divisor Latch MSB |
| DMA | Direct Memory Access |
| FIFO | First In/First Out |
| ISDN | Integrated Service Digital Network |
| LSB | Least Significant Bit |
| MSB | Most Significant Bit |
| RHR | Receive Holding Register |
| THR | Transmit Holding Register |
| TTL | Transistor-Transistor Logic |
| UART | Universal Asynchronous Receiver/Transmitter |

15. Revision history

Table 30. Revision history

| Document ID | Release date | Data sheet status | Change notice | Supersedes |
|-----------------------------------|---|--------------------|---------------|---------------|
| SC16C2550B_5 | 20090112 | Product data sheet | - | SC16C2550B_4 |
| Modifications: | <ul style="list-style-type: none"> • Section 2 “Features”: 3rd bullet item changed from “5 V tolerant inputs” to “5 V tolerant on input only pins” and added Footnote 1. • Figure 7 “Internal Loopback mode diagram”: <ul style="list-style-type: none"> – at signals coming out of ‘modem control logic’ block, changed from “$\overline{OP1A}$, $\overline{OP2B}$” to “$\overline{OP1A}$, $\overline{OP1B}$” • Table 23 “Limiting values”: <ul style="list-style-type: none"> – symbol V_n split to show 2 separate conditions: “at D7 to D0 pins” and “at input only pins” • Table 24 “Static characteristics”: <ul style="list-style-type: none"> – changed symbol/parameter from “$V_{IL(CK)}$, LOW-level clock input voltage” to “$V_{IL(clk)}$, clock LOW-level input voltage” – changed symbol/parameter from “$V_{IH(CK)}$, HIGH-level clock input voltage” to “$V_{IH(clk)}$, clock HIGH-level input voltage” – changed symbol/parameter from “I_{CL}, clock leakage” to “$I_{L(clk)}$, clock leakage current” • Table 25 “Dynamic characteristics”: added Table note [4] and its reference at t_{RESET} • updated soldering information | | | |
| SC16C2550B_4 | 20070215 | Product data sheet | - | SC16C2550B_3 |
| SC16C2550B_3 | 20050926 | Product data sheet | - | SC16C2550B-02 |
| SC16C2550B-02 (9397 750 14449) | 20041214 | Product data | - | SC16C2550B-01 |
| SC16C2550B-01 (9397 750 11982) | 20050719 | Product data | - | - |

16. Legal information

16.1 Data sheet status

| Document status ^{[1][2]} | Product status ^[3] | Definition |
|-----------------------------------|-------------------------------|---|
| Objective [short] data sheet | Development | This document contains data from the objective specification for product development. |
| Preliminary [short] data sheet | Qualification | This document contains data from the preliminary specification. |
| Product [short] data sheet | Production | This document contains the product specification. |

[1] Please consult the most recently issued document before initiating or completing a design.

[2] The term 'short data sheet' is explained in section "Definitions".

[3] The product status of device(s) described in this document may have changed since this document was published and may differ in case of multiple devices. The latest product status information is available on the Internet at URL <http://www.nxp.com>.

16.2 Definitions

Draft — The document is a draft version only. The content is still under internal review and subject to formal approval, which may result in modifications or additions. NXP Semiconductors does not give any representations or warranties as to the accuracy or completeness of information included herein and shall have no liability for the consequences of use of such information.

Short data sheet — A short data sheet is an extract from a full data sheet with the same product type number(s) and title. A short data sheet is intended for quick reference only and should not be relied upon to contain detailed and full information. For detailed and full information see the relevant full data sheet, which is available on request via the local NXP Semiconductors sales office. In case of any inconsistency or conflict with the short data sheet, the full data sheet shall prevail.

16.3 Disclaimers

General — Information in this document is believed to be accurate and reliable. However, NXP Semiconductors does not give any representations or warranties, expressed or implied, as to the accuracy or completeness of such information and shall have no liability for the consequences of use of such information.

Right to make changes — NXP Semiconductors reserves the right to make changes to information published in this document, including without limitation specifications and product descriptions, at any time and without notice. This document supersedes and replaces all information supplied prior to the publication hereof.

Suitability for use — NXP Semiconductors products are not designed, authorized or warranted to be suitable for use in medical, military, aircraft, space or life support equipment, nor in applications where failure or

malfunction of an NXP Semiconductors product can reasonably be expected to result in personal injury, death or severe property or environmental damage. NXP Semiconductors accepts no liability for inclusion and/or use of NXP Semiconductors products in such equipment or applications and therefore such inclusion and/or use is at the customer's own risk.

Applications — Applications that are described herein for any of these products are for illustrative purposes only. NXP Semiconductors makes no representation or warranty that such applications will be suitable for the specified use without further testing or modification.

Limiting values — Stress above one or more limiting values (as defined in the Absolute Maximum Ratings System of IEC 60134) may cause permanent damage to the device. Limiting values are stress ratings only and operation of the device at these or any other conditions above those given in the Characteristics sections of this document is not implied. Exposure to limiting values for extended periods may affect device reliability.

Terms and conditions of sale — NXP Semiconductors products are sold subject to the general terms and conditions of commercial sale, as published at <http://www.nxp.com/profile/terms>, including those pertaining to warranty, intellectual property rights infringement and limitation of liability, unless explicitly otherwise agreed to in writing by NXP Semiconductors. In case of any inconsistency or conflict between information in this document and such terms and conditions, the latter will prevail.

No offer to sell or license — Nothing in this document may be interpreted or construed as an offer to sell products that is open for acceptance or the grant, conveyance or implication of any license under any copyrights, patents or other industrial or intellectual property rights.

16.4 Trademarks

Notice: All referenced brands, product names, service names and trademarks are the property of their respective owners.

17. Contact information

For more information, please visit: <http://www.nxp.com>

For sales office addresses, please send an email to: salesaddresses@nxp.com

18. Contents

| | | | | | |
|-----------|--|-----------|-----------|---|-----------|
| 1 | General description | 1 | 12.4 | Reflow soldering | 38 |
| 2 | Features | 1 | 13 | Soldering of through-hole mount packages . 39 | |
| 3 | Ordering information | 2 | 13.1 | Introduction to soldering through-hole mount packages | 39 |
| 3.1 | Ordering options | 2 | 13.2 | Soldering by dipping or by solder wave | 39 |
| 4 | Block diagram | 3 | 13.3 | Manual soldering | 39 |
| 5 | Pinning information | 4 | 13.4 | Package related soldering information | 40 |
| 5.1 | Pinning | 4 | 14 | Abbreviations | 40 |
| 5.2 | Pin description | 6 | 15 | Revision history | 41 |
| 6 | Functional description | 9 | 16 | Legal information | 42 |
| 6.1 | UART A-B functions | 9 | 16.1 | Data sheet status | 42 |
| 6.2 | Internal registers | 10 | 16.2 | Definitions | 42 |
| 6.3 | FIFO operation | 11 | 16.3 | Disclaimers | 42 |
| 6.4 | Hardware/software and time-out interrupts | 11 | 16.4 | Trademarks | 42 |
| 6.5 | Programmable baud rate generator | 12 | 17 | Contact information | 42 |
| 6.6 | DMA operation | 13 | 18 | Contents | 43 |
| 6.7 | Loopback mode | 13 | | | |
| 7 | Register descriptions | 15 | | | |
| 7.1 | Transmit Holding Register (THR) and Receive Holding Register (RHR) | 15 | | | |
| 7.2 | Interrupt Enable Register (IER) | 16 | | | |
| 7.2.1 | IER versus Transmit/Receive FIFO interrupt mode operation | 17 | | | |
| 7.2.2 | IER versus Receive/Transmit FIFO polled mode operation | 17 | | | |
| 7.3 | FIFO Control Register (FCR) | 17 | | | |
| 7.3.1 | DMA mode | 17 | | | |
| 7.3.1.1 | Mode 0 (FCR bit 3 = 0) | 17 | | | |
| 7.3.1.2 | Mode 1 (FCR bit 3 = 1) | 17 | | | |
| 7.3.2 | FIFO mode | 18 | | | |
| 7.4 | Interrupt Status Register (ISR) | 19 | | | |
| 7.5 | Line Control Register (LCR) | 20 | | | |
| 7.6 | Modem Control Register (MCR) | 21 | | | |
| 7.7 | Line Status Register (LSR) | 22 | | | |
| 7.8 | Modem Status Register (MSR) | 23 | | | |
| 7.9 | Scratchpad Register (SPR) | 24 | | | |
| 7.10 | SC16C2550B external reset condition | 24 | | | |
| 8 | Limiting values | 25 | | | |
| 9 | Static characteristics | 25 | | | |
| 10 | Dynamic characteristics | 26 | | | |
| 10.1 | Timing diagrams | 27 | | | |
| 11 | Package outline | 33 | | | |
| 12 | Soldering of SMD packages | 37 | | | |
| 12.1 | Introduction to soldering | 37 | | | |
| 12.2 | Wave and reflow soldering | 37 | | | |
| 12.3 | Wave soldering | 37 | | | |

Please be aware that important notices concerning this document and the product(s) described herein, have been included in section 'Legal information'.

