

# DATA SHEET

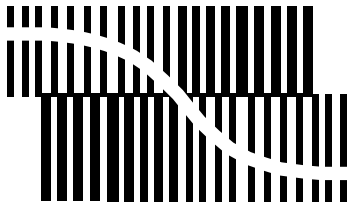

BITSTREAM CONVERSION

## **UDA1334BTS** Low power audio DAC

Product specification  
Supersedes data of 2000 Feb 07

2000 Jul 31



**Low power audio DAC****UDA1334BTS**

<b>CONTENTS</b>	13	<b>DC CHARACTERISTICS</b>	
1	<b>FEATURES</b>	14	<b>AC CHARACTERISTICS</b>
1.1	General	14.1	2.0 V supply voltage
1.2	Multiple format data interface	14.2	3.0 V supply voltage
1.3	DAC digital sound processing	14.3	Timing
1.4	Advanced audio configuration	15	<b>APPLICATION INFORMATION</b>
2	<b>APPLICATIONS</b>	16	<b>PACKAGE OUTLINE</b>
3	<b>GENERAL DESCRIPTION</b>	17	<b>SOLDERING</b>
4	<b>ORDERING INFORMATION</b>	17.1	Introduction to soldering surface mount packages
5	<b>QUICK REFERENCE DATA</b>	17.2	Reflow soldering
6	<b>BLOCK DIAGRAM</b>	17.3	Wave soldering
7	<b>PINNING</b>	17.4	Manual soldering
8	<b>FUNCTIONAL DESCRIPTION</b>	17.5	Suitability of surface mount IC packages for wave and reflow soldering methods
8.1	System clock	18	<b>DATA SHEET STATUS</b>
8.2	Interpolation filter	19	<b>DISCLAIMERS</b>
8.3	Noise shaper		
8.4	Filter stream DAC		
8.5	Power-on reset		
8.6	Feature settings		
8.6.1	Digital interface format select		
8.6.2	Mute control		
8.6.3	De-emphasis control		
8.6.4	Power control and sampling frequency select		
9	<b>LIMITING VALUES</b>		
10	<b>HANDLING</b>		
11	<b>THERMAL CHARACTERISTICS</b>		
12	<b>QUALITY SPECIFICATION</b>		

# Low power audio DAC

# UDA1334BTS

## 1 FEATURES

### 1.1 General

- 1.8 to 3.6 V power supply voltage
- Integrated digital filter plus DAC
- Supports sample frequencies from 8 to 100 kHz
- Automatic system clock versus sample rate detection
- Low power consumption
- No analog post filtering required for DAC
- Slave mode only applications
- Easy application
- SSOP16 package.

### 1.2 Multiple format data interface

- I<sup>2</sup>S-bus and LSB-justified format compatible
- 1f<sub>s</sub> input data rate.

### 1.3 DAC digital sound processing

- Digital de-emphasis for 44.1 kHz sampling rate
- Mute function.

### 1.4 Advanced audio configuration

- High linearity, wide dynamic range and low distortion
- Standby or Sleep mode in which the DAC is powered down.

## 4 ORDERING INFORMATION

TYPE NUMBER	PACKAGE		
	NAME	DESCRIPTION	VERSION
UDA1334BTS	SSOP16	plastic shrink small outline package; 16 leads; body width 4.4 mm	SOT369-1

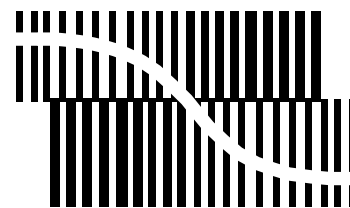

BITSTREAM CONVERSION

## 2 APPLICATIONS

This audio DAC is excellently suitable for digital audio portable application, such as portable MD, MP3 and DVD players.

## 3 GENERAL DESCRIPTION

The UDA1334BTS supports the I<sup>2</sup>S-bus data format with word lengths of up to 24 bits and the LSB-justified serial data format with word lengths of 16, 20 and 24 bits.

The UDA1334BTS has basic features such as de-emphasis (at 44.1 kHz sampling rate) and mute.

## Low power audio DAC

## UDA1334BTS

## 5 QUICK REFERENCE DATA

SYMBOL	PARAMETER	CONDITIONS	MIN.	TYP.	MAX.	UNIT
<b>Supplies</b>						
$V_{DDA}$	DAC analog supply voltage		1.8	2.0	3.6	V
$V_{DDD}$	digital supply voltage		1.8	2.0	3.6	V
$I_{DDA}$	DAC analog supply current	normal operating mode	–	2.3	–	mA
		Sleep mode	–	125	–	$\mu$ A
$I_{DDD}$	digital supply current	normal operating mode	–	1.4	–	mA
		Sleep mode				
		clock running	–	250	–	$\mu$ A
		no clock running	–	20	–	$\mu$ A
$T_{amb}$	ambient temperature		–40	–	+85	$^{\circ}$ C
<b>Digital-to-analog converter (<math>V_{DDA} = V_{DDD} = 2.0</math> V)</b>						
$V_{o(rms)}$	output voltage (RMS value)	at 0 dB (FS) digital input; note 1	–	600	–	mV
(THD + N)/S	total harmonic distortion-plus-noise to signal ratio	$f_s = 44.1$ kHz; at 0 dB	–	–80	–	dB
		$f_s = 44.1$ kHz; at –60 dB; A-weighted	–	–37	–	dB
		$f_s = 96$ kHz; at 0 dB	–	–75	–	dB
		$f_s = 96$ kHz; at –60 dB; A-weighted	–	–35	–	dB
S/N	signal-to-noise ratio	$f_s = 44.1$ kHz; code = 0; A-weighted	–	97	–	dB
		$f_s = 96$ kHz; code = 0; A-weighted	–	95	–	dB
$\alpha_{CS}$	channel separation		–	100	–	dB
<b>Digital-to-analog converter (<math>V_{DDA} = V_{DDD} = 3.0</math> V)</b>						
$V_{o(rms)}$	output voltage (RMS value)	at 0 dB (FS) digital input; note 1	–	900	–	mV
(THD + N)/S	total harmonic distortion-plus-noise to signal ratio	$f_s = 44.1$ kHz; at 0 dB	–	–90	–	dB
		$f_s = 44.1$ kHz; at –60 dB; A-weighted	–	–40	–	dB
		$f_s = 96$ kHz; at 0 dB	–	–85	–	dB
		$f_s = 96$ kHz; at –60 dB; A-weighted	–	–37	–	dB
S/N	signal-to-noise ratio	$f_s = 44.1$ kHz; code = 0; A-weighted	–	100	–	dB
		$f_s = 96$ kHz; code = 0; A-weighted	–	98	–	dB
$\alpha_{CS}$	channel separation		–	100	–	dB
<b>Power dissipation (at <math>f_s = 44.1</math> kHz)</b>						
P	power dissipation	playback mode				
		at 2.0 V supply voltage	–	7.4	–	mW
		at 3.0 V supply voltage	–	17	–	mW
		Sleep mode; at 2.0 V supply voltage				
		clock running	–	0.75	–	mW
		no clock running	–	0.3	–	mW

**Note**

1. The DAC output voltage scales proportionally to the power supply voltage.

# Low power audio DAC

# UDA1334BTS

## 6 BLOCK DIAGRAM

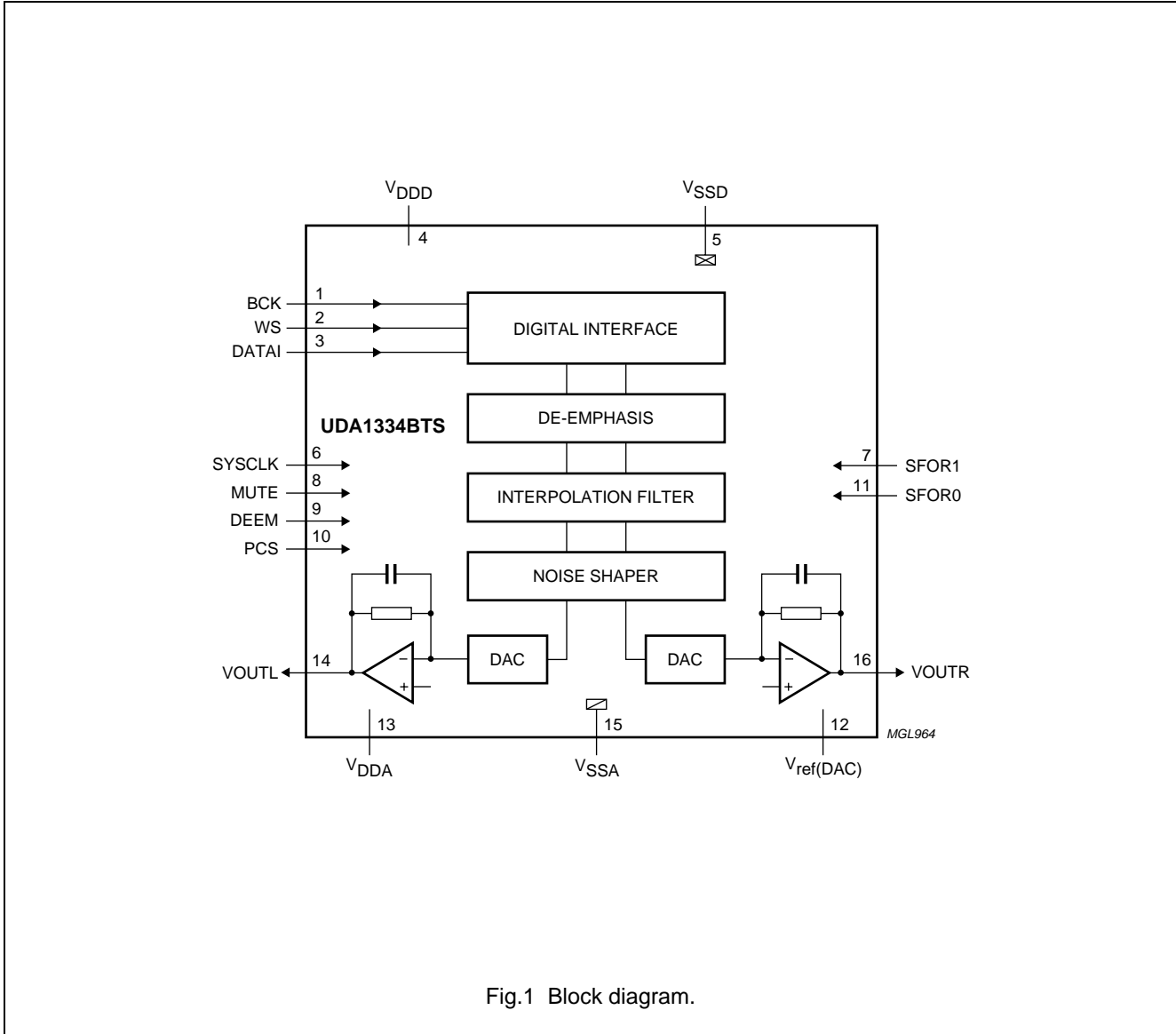

Fig.1 Block diagram.

Low power audio DAC

UDA1334BTS

7 PINNING

SYMBOL	PIN	PAD TYPE	DESCRIPTION
BCK	1	5 V tolerant digital input pad; note 1	bit clock input
WS	2	5 V tolerant digital input pad; note 1	word select input
DATAI	3	5 V tolerant digital input pad; note 1	serial data input
V <sub>DDD</sub>	4	digital supply pad	digital supply voltage
V <sub>SSD</sub>	5	digital ground pad	digital ground
SYSCLK	6	5 V tolerant digital input pad; note 1	system clock input
SFOR1	7	5 V tolerant digital input pad; note 1	serial format select 1
MUTE	8	5 V tolerant digital input pad; note 1	mute control
DEEM	9	5 V tolerant digital input pad; note 1	de-emphasis control
PCS	10	3-level input pad; note 2	power control and sampling frequency select
SFOR0	11	digital input pad; note 2	serial format select 0
V <sub>ref(DAC)</sub>	12	analog pad	DAC reference voltage
V <sub>DDA</sub>	13	analog supply pad	DAC analog supply voltage
VOUTL	14	analog output pad	DAC output left
V <sub>SSA</sub>	15	analog ground pad	DAC analog ground
VOUTR	16	analog output pad	DAC output right

Notes

1. 5 V tolerant is only supported if the power supply voltage is between 2.7 and 3.6 V. For lower power supply voltages this is maximum 3.3 V tolerant.
2. Because of test issues these pads are not 5 V tolerant and they should be at power supply voltage level or at a maximum of 0.5 V above that level.

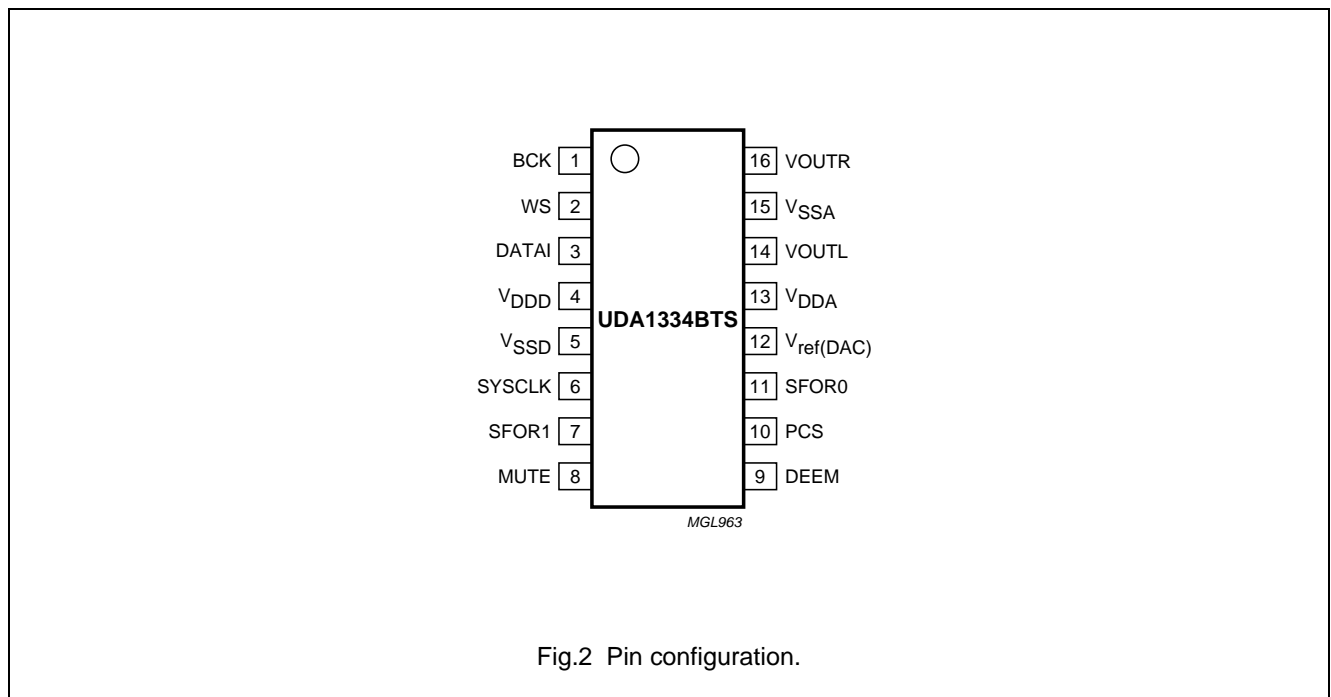

Fig.2 Pin configuration.

# Low power audio DAC

# UDA1334BTS

## 8 FUNCTIONAL DESCRIPTION

### 8.1 System clock

The UDA1334BTS operates in slave mode only; this means that in all applications the system must provide the system clock and the digital audio interface signals (BCK and WS).

The system clock must be locked in frequency to the digital interface signals.

The UDA1334BTS automatically detects the ratio between the SYSCLK and WS frequencies.

The BCK clock can be up to  $64f_s$ , or in other words the BCK frequency is 64 times the Word Select (WS) frequency or less:  $f_{BCK} \leq 64 \times f_{WS}$ .

**Remarks:**

1. The WS edge MUST fall on the negative edge of the BCK at all times for proper operation of the digital I/O data interface
2. For LSB-justified formats it is important to have a WS signal with a duty factor of 50%.

The modes which are supported are given in Table 1.

**Table 1** Supported sampling ranges

CLOCK MODE	SAMPLING RANGE
$768f_s$	8 to 55 kHz
$512f_s$	8 to 100 kHz
$384f_s$	8 to 100 kHz
$256f_s$	8 to 100 kHz
$192f_s$	8 to 100 kHz <sup>(1)(2)</sup>
$128f_s$	8 to 100 kHz <sup>(2)</sup>

**Notes**

1. This mode can only be supported for power supply voltages down to 2.4 V. For lower voltages, in  $192f_s$  mode the sampling frequency should be limited to 55 kHz.
2. Not supported in the low sampling frequency mode.

An example is given in Table 2 for a 12.228 MHz system clock input.

**Table 2** Example using a 12.228 MHz system clock

CLOCK MODE	SAMPLING FREQUENCY
$128f_s$	96 kHz
$192f_s$	64 kHz <sup>(1)</sup>
$256f_s$	48 kHz
$384f_s$	32 kHz
$512f_s$	24 kHz
$768f_s$	16 kHz

**Note**

1. This mode can only be supported for power supply voltages down to 2.4 V. For lower voltages, in  $192f_s$  mode the sampling frequency should be limited to 55 kHz.

### 8.2 Interpolation filter

The interpolation digital filter interpolates from  $1f_s$  to  $64f_s$  by cascading FIR filters (see Table 3).

**Table 3** Interpolation filter characteristics

ITEM	CONDITION	VALUE (dB)
Pass-band ripple	0 to $0.45f_s$	$\pm 0.02$
Stop band	$>0.55f_s$	-50
Dynamic range	0 to $0.45f_s$	$>114$

### 8.3 Noise shaper

The 5th-order noise shaper operates at  $64f_s$ . It shifts in-band quantization noise to frequencies well above the audio band. This noise shaping technique enables high signal-to-noise ratios to be achieved. The noise shaper output is converted into an analog signal using a Filter Stream DAC (FSDAC).

# Low power audio DAC

# UDA1334BTS

## 8.4 Filter stream DAC

The FSDAC is a semi-digital reconstruction filter that converts the 1-bit data stream of the noise shaper to an analog output voltage. The filter coefficients are implemented as current sources and are summed at virtual ground of the output operational amplifier. In this way very high signal-to-noise performance and low clock jitter sensitivity is achieved. No post-filter is needed due to the inherent filter function of the DAC. On-board amplifiers convert the FSDAC output current to an output voltage signal capable of driving a line output.

The output voltage of the FSDAC scales proportionally with the power supply voltage.

## 8.5 Power-on reset

The UDA1334BTS has an internal Power-on reset circuit (see Fig.3) which resets the test control block.

The reset time (see Fig.4) is determined by an external capacitor which is connected between pin  $V_{ref(DAC)}$  and ground. The reset time should be at least  $1 \mu s$  for  $V_{ref(DAC)} < 1.25 V$ . When  $V_{DDA}$  is switched off, the device will be reset again for  $V_{ref(DAC)} < 0.75 V$ .

During the reset time the system clock should be running.

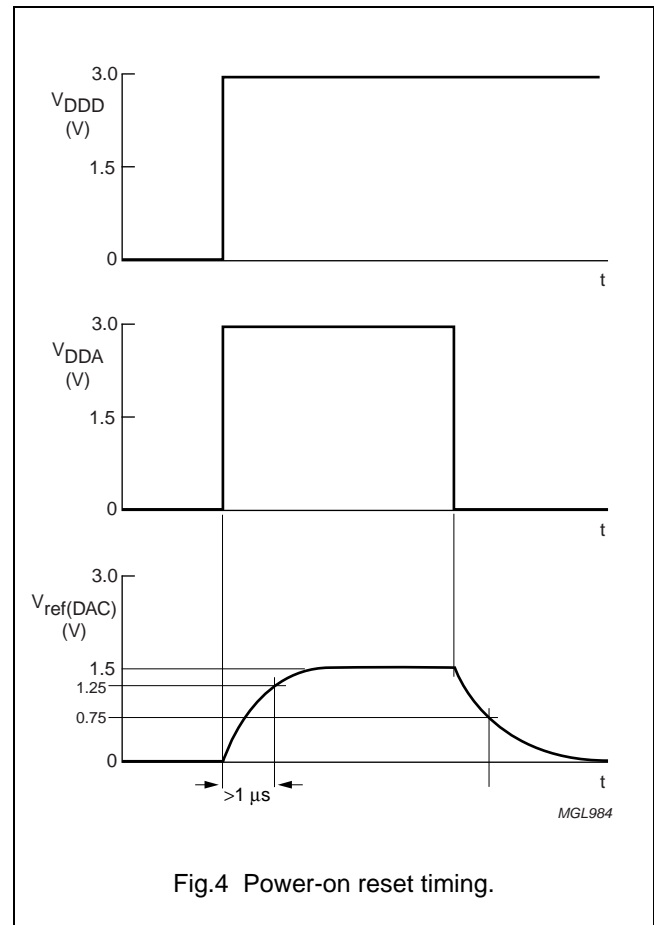
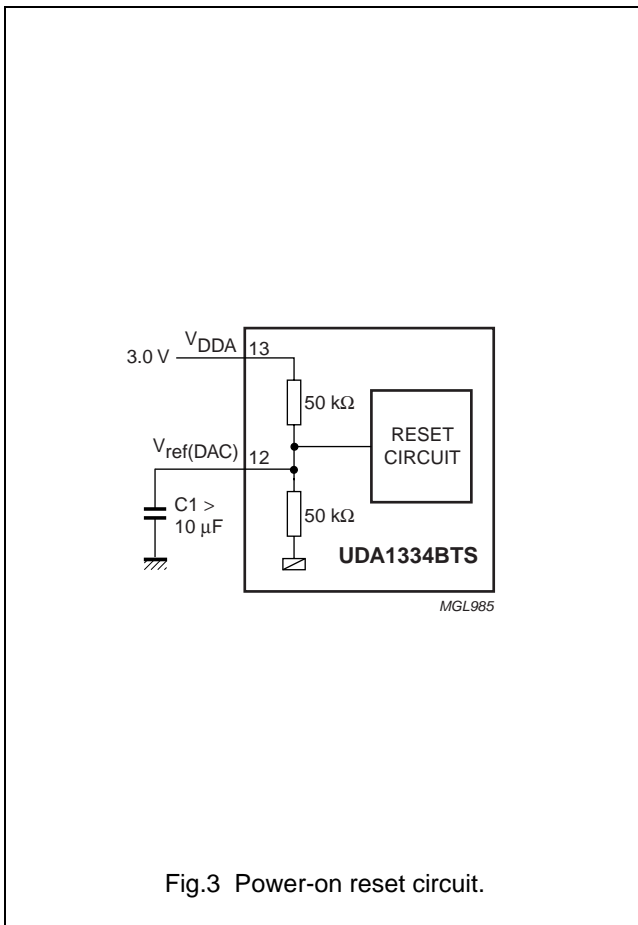

# Low power audio DAC

# UDA1334BTS

## 8.6 Feature settings

The features of the UDA1334BTS can be set by control pins SFOR1, SFOR0, MUTE, DEEM and PCS.

### 8.6.1 DIGITAL INTERFACE FORMAT SELECT

The digital audio interface formats (see Fig.5) can be selected via the pins SFOR1 and SFOR0 as shown in Table 4.

**Table 4** Data format selection

SFOR1	SFOR0	INPUT FORMAT
LOW	LOW	I <sup>2</sup> S-bus input
LOW	HIGH	LSB-justified 16 bits input
HIGH	LOW	LSB-justified 20 bits input
HIGH	HIGH	LSB-justified 24 bits input

### 8.6.2 MUTE CONTROL

The output signal can be soft muted by setting pin MUTE to HIGH level as shown in Table 5.

**Table 5** Mute control

MUTE	FUNCTION
LOW	mute off
HIGH	mute on

### 8.6.3 DE-EMPHASIS CONTROL

De-emphasis can be switched on for  $f_s = 44.1$  kHz by setting pin DEEM at HIGH level. The function description of pin DEEM is given in Table 6.

**Table 6** De-emphasis control

DEEM	FUNCTION
LOW	de-emphasis off
HIGH	de-emphasis on

**Remark:** the de-emphasis function is only supported in the normal operating mode, not in the low sampling frequency mode.

### 8.6.4 POWER CONTROL AND SAMPLING FREQUENCY SELECT

Pin PCS is a 3-level pin and is used to set the mode of the UDA1334BTS. The definition is given in Table 7.

**Table 7** PCS function definition

PCS	FUNCTION
LOW	normal operating mode
MID	low sampling frequency mode
HIGH	Power-down or Sleep mode

The low sampling frequency mode is required to have a higher oversampling rate in the noise shaper in order to improve the signal-to-noise ratio. In this mode the oversampling ratio of the noise shaper will be  $128f_s$  instead of  $64f_s$ .

Low power audio DAC

UDA1334BTS

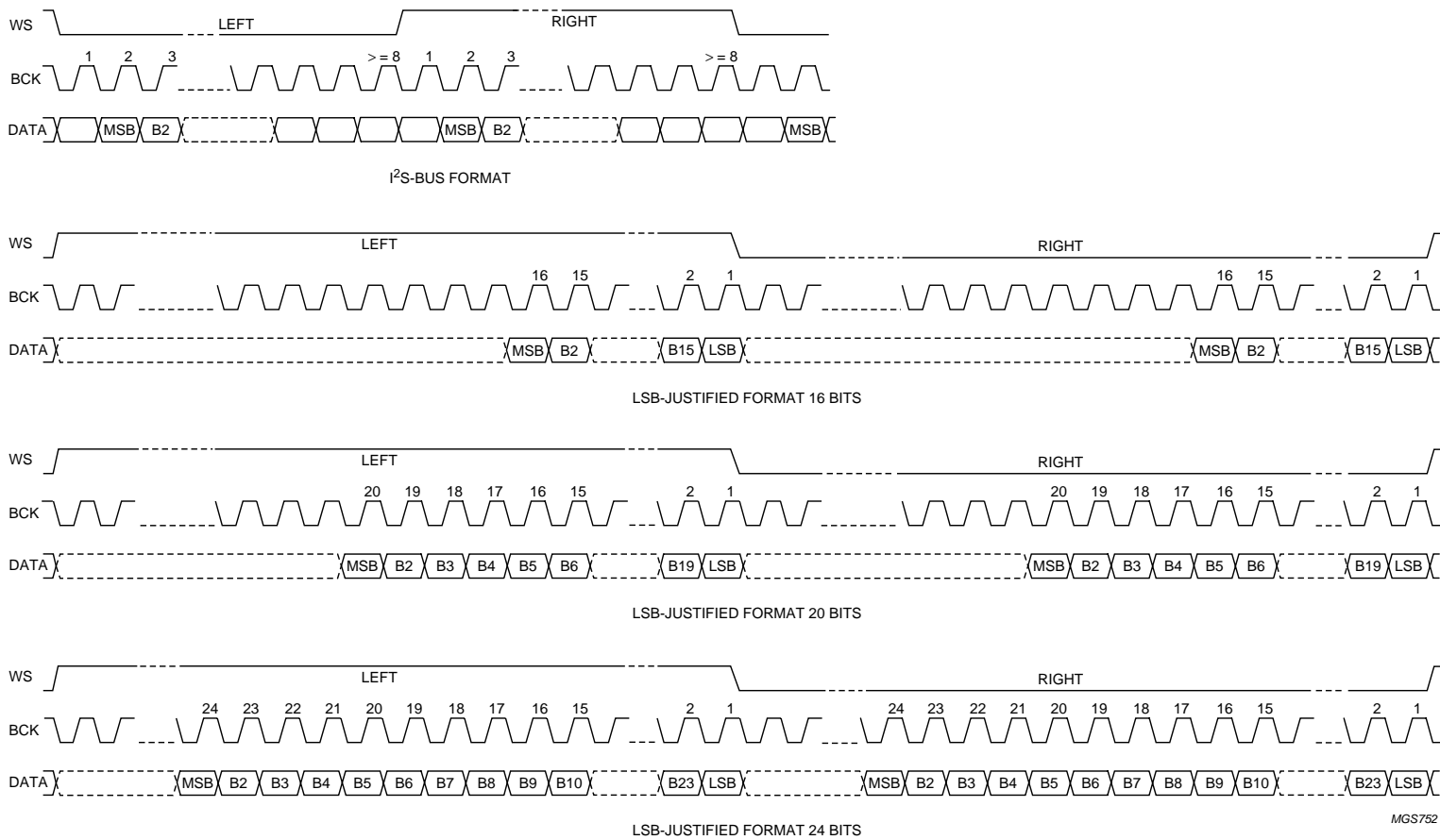

Fig.5 Digital audio formats

## Low power audio DAC

## UDA1334BTS

**9 LIMITING VALUES**

In accordance with the Absolute Maximum Rating System (IEC 60134).

SYMBOL	PARAMETER	CONDITIONS	MIN.	MAX.	UNIT
$V_{DD}$	supply voltage	note 1	–	4.0	V
$T_{xtal(max)}$	maximum crystal temperature		–	150	°C
$T_{stg}$	storage temperature		–65	+125	°C
$T_{amb}$	ambient temperature		–40	+85	°C
$V_{es}$	electrostatic handling voltage	human body model	–2000	+2000	V
		machine model	–200	+200	V
$I_{sc(DAC)}$	short-circuit current of DAC	note 2			
		output short-circuited to $V_{SSA}$	–	450	mA
		output short-circuited to $V_{DDA}$	–	300	mA

**Note**

- All supply connections must be made to the same power supply.
- Short-circuit test at  $T_{amb} = 0\text{ °C}$  and  $V_{DDA} = 3\text{ V}$ . DAC operation after short-circuiting cannot be warranted.

**10 HANDLING**

Inputs and outputs are protected against electrostatic discharge in normal handling. However, it is good practice to take normal precautions appropriate to handling MOS devices.

**11 THERMAL CHARACTERISTICS**

SYMBOL	PARAMETER	CONDITIONS	VALUE	UNIT
$R_{th(j-a)}$	thermal resistance from junction to ambient	in free air	145	K/W

**12 QUALITY SPECIFICATION**

In accordance with “SNW-FQ-611-E”.

**13 DC CHARACTERISTICS**

$V_{DDD} = V_{DDA} = 2.0\text{ V}$ ;  $T_{amb} = 25\text{ °C}$ ;  $R_L = 5\text{ k}\Omega$ ; all voltages with respect to ground (pins  $V_{SSA}$  and  $V_{SSD}$ ); unless otherwise specified.

SYMBOL	PARAMETER	CONDITIONS	MIN.	TYP.	MAX.	UNIT
<b>Supplies</b>						
$V_{DDA}$	DAC analog supply voltage	note 1	1.8	2.0	3.6	V
$V_{DDD}$	digital supply voltage	note 1	1.8	2.0	3.6	V
$I_{DDA}$	DAC analog supply current	normal operating mode				
		at 2.0 V supply voltage	–	2.3	–	mA
		at 3.0 V supply voltage	–	3.5	–	mA
		Sleep mode				
		at 2.0 V supply voltage	–	125	–	$\mu\text{A}$
		at 3.0 V supply voltage	–	175	–	$\mu\text{A}$

## Low power audio DAC

## UDA1334BTS

SYMBOL	PARAMETER	CONDITIONS	MIN.	TYP.	MAX.	UNIT	
I <sub>DDD</sub>	digital supply current	normal operating mode					
		at 2.0 V supply voltage	–	1.4	–	mA	
		at 3.0 V supply voltage	–	2.1	–	mA	
		Sleep mode;					
		at 2.0 V supply voltage					
		clock running	–	250	–	μA	
no clock running	–	20	–	μA			
Sleep mode;	at 3.0 V supply voltage	clock running	–	375	–	μA	
		no clock running	–	30	–	μA	
<b>Digital input pins; note 2</b>							
V <sub>IH</sub>	HIGH-level input voltage	at 2.0 V supply voltage	1.3	–	3.3	V	
		at 3.0 V supply voltage	2.0	–	5.0	V	
V <sub>IL</sub>	LOW-level input voltage	at 2.0 V supply voltage	–0.5	–	+0.5	V	
		at 3.0 V supply voltage	–0.5	–	+0.8	V	
I <sub>LI</sub>	input leakage current		–	–	1	μA	
C <sub>i</sub>	input capacitance		–	–	10	pF	
<b>3-level input: pin PCS</b>							
V <sub>IH</sub>	HIGH-level input voltage		0.9V <sub>DDD</sub>	–	V <sub>DDD</sub> + 0.5	V	
V <sub>IM</sub>	MID-level input voltage		0.4V <sub>DDD</sub>	–	0.6V <sub>DDD</sub>	V	
V <sub>IL</sub>	LOW-level input voltage		–0.5	–	+0.5	V	
<b>DAC</b>							
V <sub>ref(DAC)</sub>	reference voltage	with respect to V <sub>SSA</sub>	0.45V <sub>DDA</sub>	0.5V <sub>DDA</sub>	0.55V <sub>DDA</sub>	V	
R <sub>o(ref)</sub>	output resistance on pin V <sub>ref(DAC)</sub>		–	25	–	kΩ	
I <sub>o(max)</sub>	maximum output current	(THD + N)/S < 0.1%; R <sub>L</sub> = 800 Ω	–	1.6	–	mA	
R <sub>L</sub>	load resistance		3	–	–	kΩ	
C <sub>L</sub>	load capacitance	note 3	–	–	50	pF	

**Notes**

1. All supply connections must be made to the same external power supply unit.
2. At 3 V supply voltage, the input pads are TTL compatible. However, at 2.0 V supply voltage no TTL levels can be accepted, but levels from 3.3 V domain can be applied to the pins.
3. When the DAC drives a capacitive load above 50 pF, a series resistance of 100 Ω must be used to prevent oscillations in the output operational amplifier.

## Low power audio DAC

## UDA1334BTS

**14 AC CHARACTERISTICS****14.1 2.0 V supply voltage**

$V_{DD} = V_{DDA} = 2.0$  V;  $f_i = 1$  kHz;  $T_{amb} = 25$  °C;  $R_L = 5$  k $\Omega$ .; all voltages with respect to ground (pins  $V_{SSA}$  and  $V_{SSD}$ ); unless otherwise specified.

SYMBOL	PARAMETER	CONDITIONS	MIN.	TYP.	MAX.	UNIT
<b>DAC</b>						
$V_{o(rms)}$	output voltage (RMS value)	at 0 dB (FS) digital input	–	600	–	mV
$\Delta V_o$	unbalance between channels		–	0.1	–	dB
(THD + N)/S	total harmonic distortion-plus-noise to signal ratio	$f_s = 44.1$ kHz; at 0 dB	–	–80	–	dB
		$f_s = 44.1$ kHz; at –60 dB; A-weighted	–	–37	–	dB
		$f_s = 96$ kHz; at 0 dB	–	–75	–	dB
		$f_s = 96$ kHz; at –60 dB; A-weighted	–	–35	–	dB
S/N	signal-to-noise ratio	$f_s = 44.1$ kHz; code = 0; A-weighted	–	97	–	dB
		$f_s = 96$ kHz; code = 0; A-weighted	–	95	–	dB
$\alpha_{cs}$	channel separation		–	100	–	dB
PSRR	power supply rejection ratio	$f_{ripple} = 1$ kHz; $V_{ripple} = 30$ mV (p-p)	–	60	–	dB

**14.2 3.0 V supply voltage**

$V_{DD} = V_{DDA} = 3.0$  V;  $f_i = 1$  kHz;  $T_{amb} = 25$  °C;  $R_L = 5$  k $\Omega$ .; all voltages with respect to ground (pins  $V_{SSA}$  and  $V_{SSD}$ ); unless otherwise specified.

SYMBOL	PARAMETER	CONDITIONS	MIN.	TYP.	MAX.	UNIT
<b>DAC</b>						
$V_{o(rms)}$	output voltage (RMS value)	at 0 dB (FS) digital input	–	900	–	mV
$\Delta V_o$	unbalance between channels		–	0.1	–	dB
(THD + N)/S	total harmonic distortion-plus-noise to signal ratio	$f_s = 44.1$ kHz; at 0 dB	–	–90	–	dB
		$f_s = 44.1$ kHz; at –60 dB; A-weighted	–	–40	–	dB
		$f_s = 96$ kHz; at 0 dB	–	–85	–	dB
		$f_s = 96$ kHz; at –60 dB; A-weighted	–	–37	–	dB
S/N	signal-to-noise ratio	$f_s = 44.1$ kHz; code = 0; A-weighted	–	100	–	dB
		$f_s = 96$ kHz; code = 0; A-weighted	–	98	–	dB
$\alpha_{cs}$	channel separation		–	100	–	dB
PSRR	power supply rejection ratio	$f_{ripple} = 1$ kHz; $V_{ripple} = 30$ mV (p-p)	–	60	–	dB

Low power audio DAC

UDA1334BTS

14.3 Timing

$V_{DD} = V_{DDA} = 1.8$  to  $3.6$  V;  $T_{amb} = -20$  to  $+85$  °C;  $R_L = 5$  k $\Omega$ ; all voltages with respect to ground (pins  $V_{SSA}$  and  $V_{SSD}$ ); unless otherwise specified; note 1.

SYMBOL	PARAMETER	CONDITIONS	MIN.	TYP.	MAX.	UNIT
<b>System clock timing</b> (see Fig.6)						
$T_{sys}$	system clock cycle time	$f_{sys} = 256f_s$	35	88	780	ns
		$f_{sys} = 384f_s$	23	59	520	ns
		$f_{sys} = 512f_s$	17	44	390	ns
$t_{CWH}$	system clock HIGH time	$f_{sys} < 19.2$ MHz	$0.3T_{sys}$	–	$0.7T_{sys}$	ns
		$f_{sys} \geq 19.2$ MHz	$0.4T_{sys}$	–	$0.6T_{sys}$	ns
$t_{CWL}$	system clock LOW time	$f_{sys} < 19.2$ MHz	$0.3T_{sys}$	–	$0.7T_{sys}$	ns
		$f_{sys} \geq 19.2$ MHz	$0.4T_{sys}$	–	$0.6T_{sys}$	ns
<b>Reset timing</b>						
$t_{reset}$	reset time		1	–	–	$\mu$ S
<b>Serial interface timing</b> (see Fig.7)						
$f_{BCK}$	bit clock frequency		–	–	$64f_s$	Hz
$t_{BCKH}$	bit clock HIGH time		50	–	–	ns
$t_{BCKL}$	bit clock LOW time		50	–	–	ns
$t_r$	rise time		–	–	20	ns
$t_f$	fall time		–	–	20	ns
$t_{su}(DATAI)$	set-up time data input		20	–	–	ns
$t_h(DATAI)$	hold time data input		0	–	–	ns
$t_{su}(WS)$	set-up time word select		20	–	–	ns
$t_h(WS)$	hold time word select		10	–	–	ns

Note

1. The typical value of the timing is specified at  $f_s = 44.1$  kHz (sampling frequency).

Low power audio DAC

UDA1334BTS

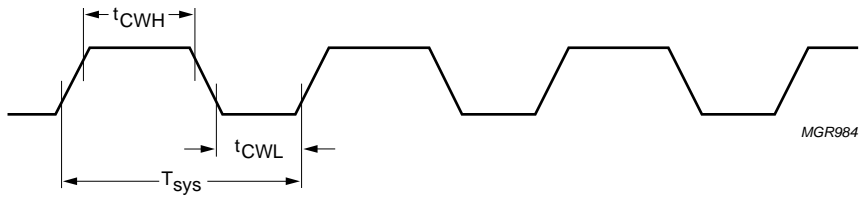

Fig.6 System clock timing.

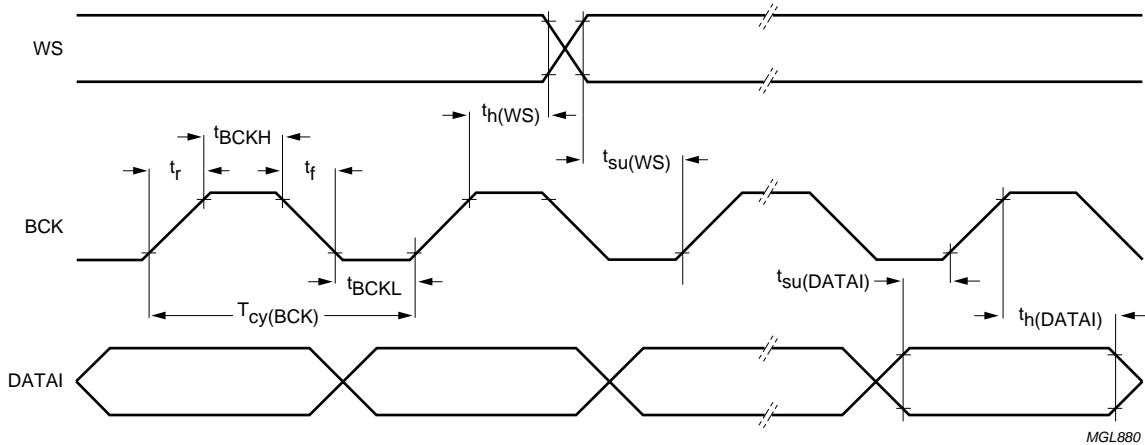

Fig.7 Serial interface timing.

# Low power audio DAC

# UDA1334BTS

## 15 APPLICATION INFORMATION

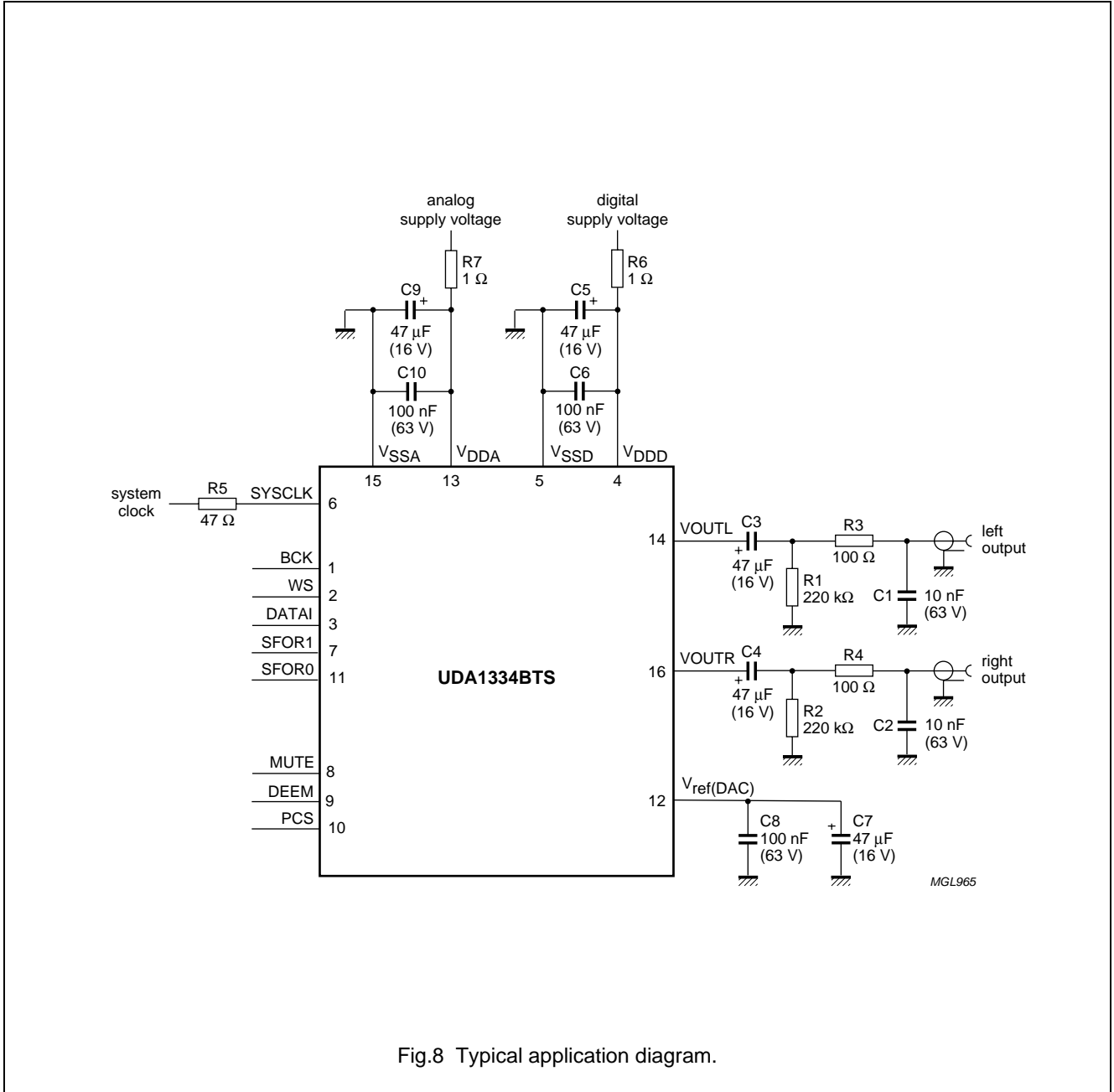

Fig.8 Typical application diagram.

Low power audio DAC

UDA1334BTS

16 PACKAGE OUTLINE

SSOP16: plastic shrink small outline package; 16 leads; body width 4.4 mm

SOT369-1

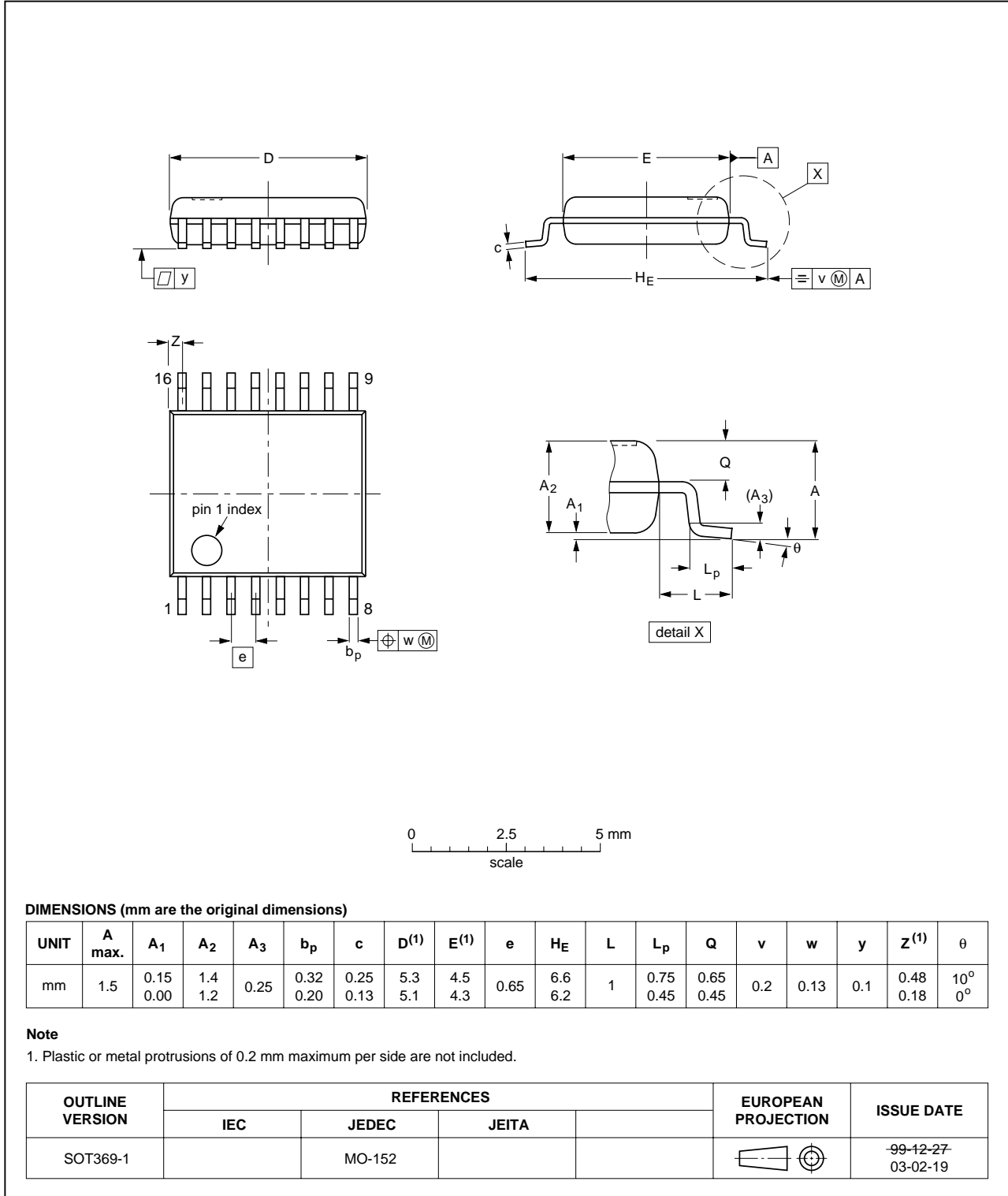

## Low power audio DAC

## UDA1334BTS

### 17 SOLDERING

#### 17.1 Introduction to soldering surface mount packages

This text gives a very brief insight to a complex technology. A more in-depth account of soldering ICs can be found in our *“Data Handbook IC26; Integrated Circuit Packages”* (document order number 9398 652 90011).

There is no soldering method that is ideal for all surface mount IC packages. Wave soldering is not always suitable for surface mount ICs, or for printed-circuit boards with high population densities. In these situations reflow soldering is often used.

#### 17.2 Reflow soldering

Reflow soldering requires solder paste (a suspension of fine solder particles, flux and binding agent) to be applied to the printed-circuit board by screen printing, stencilling or pressure-syringe dispensing before package placement.

Several methods exist for reflowing; for example, infrared/convection heating in a conveyor type oven. Throughput times (preheating, soldering and cooling) vary between 100 and 200 seconds depending on heating method.

Typical reflow peak temperatures range from 215 to 250 °C. The top-surface temperature of the packages should preferably be kept below 230 °C.

#### 17.3 Wave soldering

Conventional single wave soldering is not recommended for surface mount devices (SMDs) or printed-circuit boards with a high component density, as solder bridging and non-wetting can present major problems.

To overcome these problems the double-wave soldering method was specifically developed.

If wave soldering is used the following conditions must be observed for optimal results:

- Use a double-wave soldering method comprising a turbulent wave with high upward pressure followed by a smooth laminar wave.
- For packages with leads on two sides and a pitch (e):
  - larger than or equal to 1.27 mm, the footprint longitudinal axis is **preferred** to be parallel to the transport direction of the printed-circuit board;
  - smaller than 1.27 mm, the footprint longitudinal axis **must** be parallel to the transport direction of the printed-circuit board.

The footprint must incorporate solder thieves at the downstream end.

- For packages with leads on four sides, the footprint must be placed at a 45° angle to the transport direction of the printed-circuit board. The footprint must incorporate solder thieves downstream and at the side corners.

During placement and before soldering, the package must be fixed with a droplet of adhesive. The adhesive can be applied by screen printing, pin transfer or syringe dispensing. The package can be soldered after the adhesive is cured.

Typical dwell time is 4 seconds at 250 °C.

A mildly-activated flux will eliminate the need for removal of corrosive residues in most applications.

#### 17.4 Manual soldering

Fix the component by first soldering two diagonally-opposite end leads. Use a low voltage (24 V or less) soldering iron applied to the flat part of the lead. Contact time must be limited to 10 seconds at up to 300 °C.

When using a dedicated tool, all other leads can be soldered in one operation within 2 to 5 seconds between 270 and 320 °C.

## Low power audio DAC

## UDA1334BTS

## 17.5 Suitability of surface mount IC packages for wave and reflow soldering methods

PACKAGE	SOLDERING METHOD	
	WAVE	REFLOW <sup>(1)</sup>
BGA, LFBGA, SQFP, TFBGA	not suitable	suitable
HLQFP, HSQFP, HSOP, HTQFP, HTSSOP, SMS	not suitable <sup>(2)</sup>	suitable
PLCC <sup>(3)</sup> , SO, SOJ	suitable	suitable
LQFP, QFP, TQFP	not recommended <sup>(3)(4)</sup>	suitable
SSOP, TSSOP, VSO	not recommended <sup>(5)</sup>	suitable

**Notes**

1. All surface mount (SMD) packages are moisture sensitive. Depending upon the moisture content, the maximum temperature (with respect to time) and body size of the package, there is a risk that internal or external package cracks may occur due to vaporization of the moisture in them (the so called popcorn effect). For details, refer to the Drypack information in the *"Data Handbook IC26; Integrated Circuit Packages; Section: Packing Methods"*.
2. These packages are not suitable for wave soldering as a solder joint between the printed-circuit board and heatsink (at bottom version) can not be achieved, and as solder may stick to the heatsink (on top version).
3. If wave soldering is considered, then the package must be placed at a 45° angle to the solder wave direction. The package footprint must incorporate solder thieves downstream and at the side corners.
4. Wave soldering is only suitable for LQFP, TQFP and QFP packages with a pitch (e) equal to or larger than 0.8 mm; it is definitely not suitable for packages with a pitch (e) equal to or smaller than 0.65 mm.
5. Wave soldering is only suitable for SSOP and TSSOP packages with a pitch (e) equal to or larger than 0.65 mm; it is definitely not suitable for packages with a pitch (e) equal to or smaller than 0.5 mm.

# Low power audio DAC

# UDA1334BTS

## 18 DATA SHEET STATUS

DOCUMENT STATUS <sup>(1)</sup>	PRODUCT STATUS <sup>(2)</sup>	DEFINITION
Objective data sheet	Development	This document contains data from the objective specification for product development.
Preliminary data sheet	Qualification	This document contains data from the preliminary specification.
Product data sheet	Production	This document contains the product specification.

### Notes

1. Please consult the most recently issued document before initiating or completing a design.
2. The product status of device(s) described in this document may have changed since this document was published and may differ in case of multiple devices. The latest product status information is available on the Internet at URL <http://www.nxp.com>.

## 19 DISCLAIMERS

**Limited warranty and liability** — Information in this document is believed to be accurate and reliable. However, NXP Semiconductors does not give any representations or warranties, expressed or implied, as to the accuracy or completeness of such information and shall have no liability for the consequences of use of such information.

In no event shall NXP Semiconductors be liable for any indirect, incidental, punitive, special or consequential damages (including - without limitation - lost profits, lost savings, business interruption, costs related to the removal or replacement of any products or rework charges) whether or not such damages are based on tort (including negligence), warranty, breach of contract or any other legal theory.

Notwithstanding any damages that customer might incur for any reason whatsoever, NXP Semiconductors' aggregate and cumulative liability towards customer for the products described herein shall be limited in accordance with the *Terms and conditions of commercial sale* of NXP Semiconductors.

**Right to make changes** — NXP Semiconductors reserves the right to make changes to information published in this document, including without limitation specifications and product descriptions, at any time and without notice. This document supersedes and replaces all information supplied prior to the publication hereof.

**Suitability for use** — NXP Semiconductors products are not designed, authorized or warranted to be suitable for use in life support, life-critical or safety-critical systems or equipment, nor in applications where failure or malfunction of an NXP Semiconductors product can reasonably be expected to result in personal injury, death or severe

property or environmental damage. NXP Semiconductors accepts no liability for inclusion and/or use of NXP Semiconductors products in such equipment or applications and therefore such inclusion and/or use is at the customer's own risk.

**Applications** — Applications that are described herein for any of these products are for illustrative purposes only. NXP Semiconductors makes no representation or warranty that such applications will be suitable for the specified use without further testing or modification.

Customers are responsible for the design and operation of their applications and products using NXP Semiconductors products, and NXP Semiconductors accepts no liability for any assistance with applications or customer product design. It is customer's sole responsibility to determine whether the NXP Semiconductors product is suitable and fit for the customer's applications and products planned, as well as for the planned application and use of customer's third party customer(s). Customers should provide appropriate design and operating safeguards to minimize the risks associated with their applications and products.

NXP Semiconductors does not accept any liability related to any default, damage, costs or problem which is based on any weakness or default in the customer's applications or products, or the application or use by customer's third party customer(s). Customer is responsible for doing all necessary testing for the customer's applications and products using NXP Semiconductors products in order to avoid a default of the applications and the products or of the application or use by customer's third party customer(s). NXP does not accept any liability in this respect.

---

## Low power audio DAC

## UDA1334BTS

---

**Limiting values** — Stress above one or more limiting values (as defined in the Absolute Maximum Ratings System of IEC 60134) will cause permanent damage to the device. Limiting values are stress ratings only and (proper) operation of the device at these or any other conditions above those given in the Recommended operating conditions section (if present) or the Characteristics sections of this document is not warranted. Constant or repeated exposure to limiting values will permanently and irreversibly affect the quality and reliability of the device.

**Terms and conditions of commercial sale** — NXP Semiconductors products are sold subject to the general terms and conditions of commercial sale, as published at <http://www.nxp.com/profile/terms>, unless otherwise agreed in a valid written individual agreement. In case an individual agreement is concluded only the terms and conditions of the respective agreement shall apply. NXP Semiconductors hereby expressly objects to applying the customer's general terms and conditions with regard to the purchase of NXP Semiconductors products by customer.

**No offer to sell or license** — Nothing in this document may be interpreted or construed as an offer to sell products that is open for acceptance or the grant, conveyance or implication of any license under any copyrights, patents or other industrial or intellectual property rights.

**Export control** — This document as well as the item(s) described herein may be subject to export control regulations. Export might require a prior authorization from national authorities.

**Quick reference data** — The Quick reference data is an extract of the product data given in the Limiting values and Characteristics sections of this document, and as such is not complete, exhaustive or legally binding.

**Non-automotive qualified products** — Unless this data sheet expressly states that this specific NXP Semiconductors product is automotive qualified, the product is not suitable for automotive use. It is neither qualified nor tested in accordance with automotive testing or application requirements. NXP Semiconductors accepts no liability for inclusion and/or use of non-automotive qualified products in automotive equipment or applications.

In the event that customer uses the product for design-in and use in automotive applications to automotive specifications and standards, customer (a) shall use the product without NXP Semiconductors' warranty of the product for such automotive applications, use and specifications, and (b) whenever customer uses the product for automotive applications beyond NXP Semiconductors' specifications such use shall be solely at customer's own risk, and (c) customer fully indemnifies NXP Semiconductors for any liability, damages or failed product claims resulting from customer design and use of the product for automotive applications beyond NXP Semiconductors' standard warranty and NXP Semiconductors' product specifications.

# **NXP Semiconductors**

***provides High Performance Mixed Signal and Standard Product solutions that leverage its leading RF, Analog, Power Management, Interface, Security and Digital Processing expertise***

## **Customer notification**

This data sheet was changed to reflect the new company name NXP Semiconductors, including new legal definitions and disclaimers. No changes were made to the technical content, except for package outline drawings which were updated to the latest version.

## **Contact information**

For additional information please visit: <http://www.nxp.com>

For sales offices addresses send e-mail to: [salesaddresses@nxp.com](mailto:salesaddresses@nxp.com)

© NXP B.V. 2010

All rights are reserved. Reproduction in whole or in part is prohibited without the prior written consent of the copyright owner.

The information presented in this document does not form part of any quotation or contract, is believed to be accurate and reliable and may be changed without notice. No liability will be accepted by the publisher for any consequence of its use. Publication thereof does not convey nor imply any license under patent- or other industrial or intellectual property rights.

Printed in The Netherlands

753503/25/02/pp22

Date of release: 2000 Jul 31

Document order number: 9397 750 07239