

BGA7124

400 MHz to 2700 MHz 0.25 W high linearity silicon amplifier

Rev. 3 — 9 September 2010

Product data sheet

1. Product profile

1.1 General description

The BGA7124 MMIC is a one-stage amplifier, available in a low-cost leadless surface-mount package. It delivers 25 dBm output power at 1 dB gain compression and superior performance up to 2700 MHz. Its power saving features include easy quiescent current adjustment enabling class-AB operation and logic-level shutdown control to reduce the supply current to 4 μ A.

1.2 Features and benefits

- 400 MHz to 2700 MHz frequency operating range
- 16 dB small signal gain at 2 GHz
- 25 dBm output power at 1 dB gain compression
- Integrated active biasing
- External matching allows broad application optimization of the electrical performance
- 3.3 V or 5 V single supply operation
- All pins ESD protected

1.3 Applications

- Wireless infrastructure (base station, repeater, backhaul systems)
- Broadband CPE/MoCA
- Industrial applications
- E-metering
- Satellite Master Antenna TV (SMATV)
- WLAN/ISM/RFID

1.4 Quick reference data

Table 1. Quick reference data

Input and output impedances matched to 50 Ω , $\overline{SHDN} = HIGH$ (shutdown disabled). Typical values at $V_{CC} = 5$ V; $I_{CC} = 130$ mA; $T_{case} = 25$ °C; unless otherwise specified.

Symbol	Parameter	Conditions	Min	Typ	Max	Unit
I_{CC}	supply current	$V_{CC} = 5.0$ V	[1] 50	-	170	mA
f	frequency		[2] 400	-	2700	MHz
G_p	power gain	f = 2140 MHz	14.5	16	17.5	dB
$P_{L(1dB)}$	output power at 1 dB gain compression	f = 2140 MHz	23.5	24.5	-	dBm
IP3 _O	output third-order intercept point	f = 2140 MHz	[3] 34.5	37.5	-	dBm

[1] The supply current is adjustable; see [Section 8.1 "Supply current adjustment"](#).

[2] Operation outside this range is possible but not guaranteed.

[3] $P_L = 11$ dBm per tone; spacing = 1 MHz.



2. Pinning information

2.1 Pinning

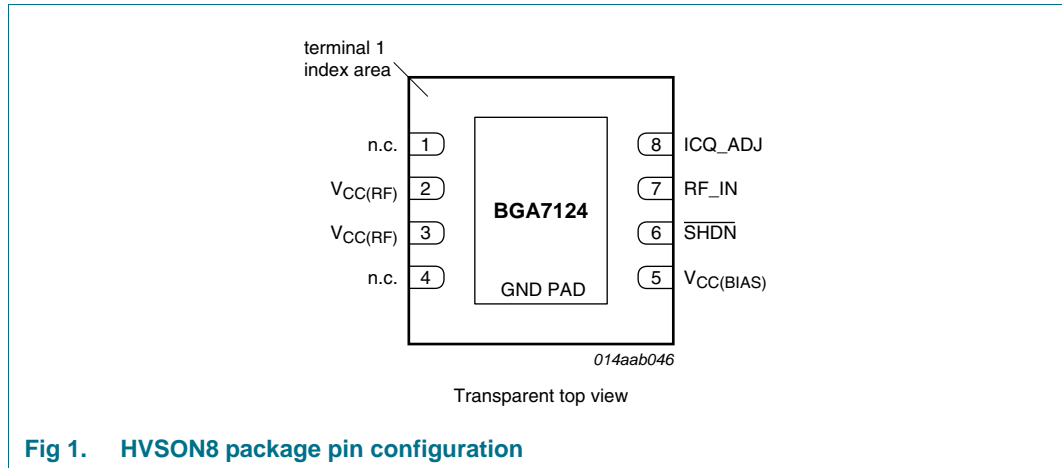

2.2 Pin description

Table 2. Pin description

Symbol	Pin	Description
n.c.	1, 4	not connected
V _{CC(RF)}	2, 3	RF output for the power amplifier and DC supply input for the RF transistor collector [1]
V _{CC(BIAS)}	5	bias supply voltage [2]
SHDN	6	shutdown control function enabled/disabled
RF_IN	7	RF input for the power amplifier [1]
ICQ_ADJ	8	quiescent collector current adjustment controlled by an external resistor
GND	GND pad	RF and DC ground [3]

[1] This pin is DC-coupled and requires an external DC-blocking capacitor.

[2] RF decoupled.

[3] The center metal base of the SOT908-1 also functions as heatsink for the power amplifier.

3. Ordering information

Table 3. Ordering information

Type number	Package		Version
	Name	Description	
BGA7124	HVSON8	plastic thermal enhanced very thin small outline package; no leads; 8 terminals; body 3 × 3 × 0.85 mm	SOT908-1

4. Functional diagram

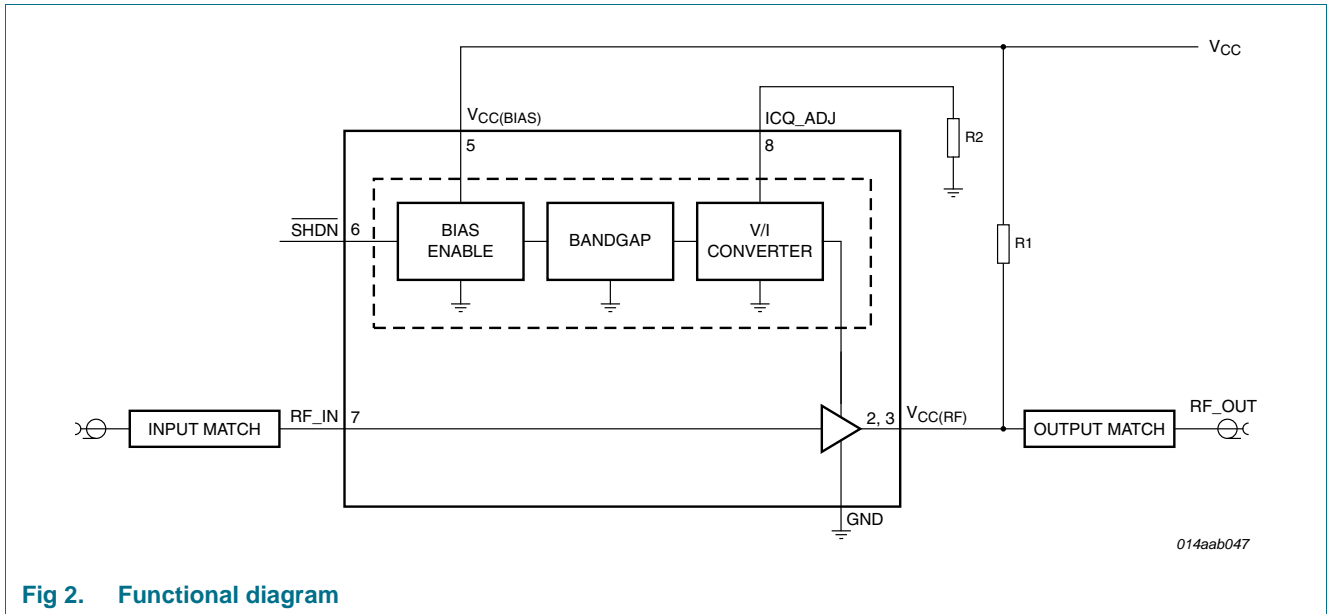

Fig 2. Functional diagram

5. Shutdown control

Table 4. Shutdown control settings

Mode	Mode description	Function description	Pin SHDN	V _{ctrl(sd)} (V)		I _{ctrl(sd)} (µA)	
				Min	Max	Min	Max
Idle	medium power MMIC fully off; minimal supply current	shutdown control enabled	0	0	0.7	-	2
TX	medium power MMIC transmit mode	shutdown control disabled	1	2.5	V _{CC(BIAS)}	-	9

6. Limiting values

Table 5. Limiting values

In accordance with the Absolute Maximum Rating System (IEC 60134).

Symbol	Parameter	Conditions	Min	Max	Unit
$V_{CC(RF)}$	RF supply voltage		[1] -	6.0	V
$V_{CC(BIAS)}$	bias supply voltage		[1] -	6.0	V
I_{CC}	supply current		[1][2] 50	200	mA
$V_{ctrl(sd)}$	shutdown control voltage		[3] 0.0	$V_{CC(BIAS)}$	V
$P_{i(RF)}$	RF input power		-	20	dBm
T_{case}	case temperature		-40	+85	°C
T_j	junction temperature		-	150	°C
V_{ESD}	electrostatic discharge voltage	Human Body Model (HBM); According JEDEC standard 22-A114E	-	2000	V
		Charged Device Model (CDM); According JEDEC standard 22-C101B	-	500	V

- [1] See [Figure 3](#) for safe operating area.
- [2] The supply current is adjustable; see [Section 8.1 "Supply current adjustment"](#).
- [3] If $V_{ctrl(sd)}$ exceeds $V_{CC(BIAS)}$, the internal ESD circuit can be damaged. To prevent this, it is recommended that the $I_{ctrl(sd)}$ is limited to 20 mA. If the SHDN function is not used, the SHDN pin should be connected to the $V_{CC(BIAS)}$ pin.

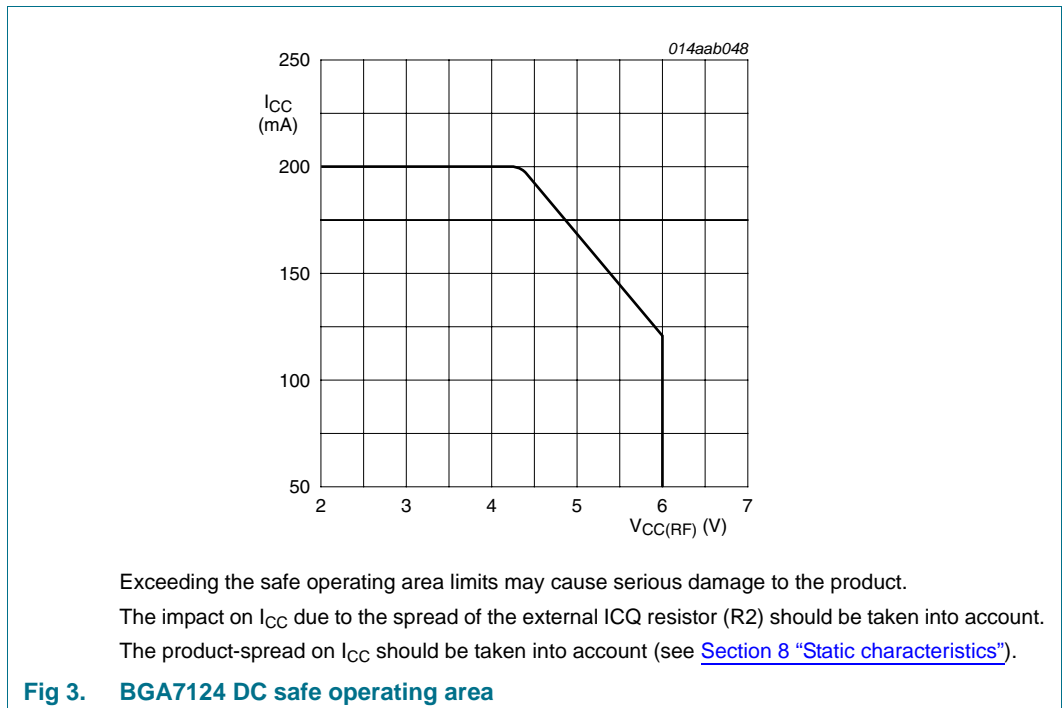

7. Thermal characteristics

Table 6. Thermal characteristics

Symbol	Parameter	Conditions	Typ	Max	Unit
$R_{th(j-mb)}$	thermal resistance from junction to mounting base	$T_{case} = 85\text{ °C}$; $V_{CC} = 5\text{ V}$; $I_{CC} = 130\text{ mA}$	[1] 32	-	K/W

[1] defined as thermal resistance from junction to GND paddle.

8. Static characteristics

Table 7. Characteristics

Input and output impedances matched to 50 Ω , pin $\overline{SHDN} = HIGH$ (shutdown disabled). Typical values at $V_{CC} = 3.3\text{ V}$ or $V_{CC} = 5\text{ V}$; $T_{case} = 25\text{ °C}$; unless otherwise specified.

Symbol	Parameter	Conditions	Min	Typ	Max	Unit
I_{CC}	supply current	$V_{CC} = 3.3\text{ V}$	[1] 50	-	200	mA
		$R1 = 0\ \Omega$; $R2 = 1330\ \Omega$	[2] 115	130	145	mA
		$R1 = 2.2\ \Omega$; $R2 = 1070\ \Omega$	[2] 135	160	185	mA
		$V_{CC} = 5.0\text{ V}$	[1] 50	-	170	mA
		$R1 = 0\ \Omega$; $R2 = 1960\ \Omega$	[2] 110	130	150	mA
		$R1 = 2.2\ \Omega$; $R2 = 1650\ \Omega$	[2] 125	150	175	mA
		during shutdown; pin $\overline{SHDN} = LOW$ (shutdown enabled)	-	4	6	μA

[1] The supply current is adjustable; see [Section 8.1 "Supply current adjustment"](#).

[2] See [Section 12 "Application information"](#).

8.1 Supply current adjustment

The supply current can be adjusted by changing the value of external ICQ resistor (R2); (see [Figure 4](#)).

Table 8. Characteristics at $V_{CC} = 5\text{ V}$...continued

Input and output impedances matched to $50\ \Omega$, pin $\overline{SHDN} = \text{HIGH}$ (shutdown disabled). Typical values at $V_{CC} = 5\text{ V}$; $I_{CC} = 130\text{ mA}$; $T_{case} = 25\text{ }^\circ\text{C}$; see [Section 12 "Application information"](#); unless otherwise specified.

Symbol	Parameter	Conditions	Min	Typ	Max	Unit
RL_{in}	input return loss	$f = 940\text{ MHz}$	-	-15	-	dB
		$f = 1960\text{ MHz}$	-	-11	-	dB
		$f = 2140\text{ MHz}$	-	-17	-	dB
		$f = 2445\text{ MHz}$	[2]	-13	-	dB
RL_{out}	output return loss	$f = 940\text{ MHz}$	-	-8	-	dB
		$f = 1960\text{ MHz}$	-	-12	-	dB
		$f = 2140\text{ MHz}$	-	-15	-	dB
		$f = 2445\text{ MHz}$	[2]	-25	-	dB

[1] Operation outside this range is possible but not guaranteed.

[2] $I_{CC} = 150\text{ mA}$; see [Section 12 "Application information"](#).

[3] $P_L = 11\text{ dBm}$ per tone; spacing = 1 MHz.

[4] Defined at $P_1 = -40\text{ dBm}$; small signal conditions.

Table 9. Characteristics at $V_{CC} = 3.3$ V

Input and output impedances matched to 50Ω , pin $\overline{SHDN} = HIGH$ (shutdown disabled). Typical values at $V_{CC} = 3.3$ V; $I_{CC} = 130$ mA; $T_{case} = 25$ °C, see [Section 12 "Application information"](#); unless otherwise specified.

Symbol	Parameter	Conditions	Min	Typ	Max	Unit	
f	frequency		[1] 400	-	2700	MHz	
G_p	power gain	for small signals					
		f = 940 MHz	-	22.5	-	dB	
		f = 2445 MHz	[2]	-	13.8	-	dB
$P_{L(1dB)}$	output power at 1 dB gain compression	f = 940 MHz	-	23.5	-	dBm	
		f = 2445 MHz	[2]	-	22.0	-	dBm
IP _{3O}	output third-order intercept point	f = 940 MHz	[3]	-	36.4	-	dBm
		f = 2445 MHz	[2][3]	-	35.2	-	dBm
NF	noise figure	f = 940 MHz	[4]	-	5.5	-	dB
		f = 2445 MHz	[2][4]	-	5.5	-	dB
RL _{in}	input return loss	f = 940 MHz	-	-15	-	dB	
		f = 2445 MHz	[2]	-	-10	-	dB
RL _{out}	output return loss	f = 940 MHz	-	-9	-	dB	
		f = 2445 MHz	[2]	-	-25	-	dB

[1] Operation outside this range is possible but not guaranteed.

[2] $I_{CC} = 160$ mA; see [Section 12 "Application information"](#).

[3] $P_L = 11$ dBm per tone; spacing = 1 MHz.

[4] Defined at $P_1 = -40$ dBm; small signal conditions.

9.1 Scattering parameters

Table 10. Scattering parameters at 5 V, MMIC only

$V_{CC} = 5\text{ V}$; $I_{CC} = 130\text{ mA}$; $T_{case} = 25\text{ }^{\circ}\text{C}$.

f (MHz)	S ₁₁		S ₂₁		S ₁₂		S ₂₂	
	Magnitude (ratio)	Angle (degree)	Magnitude (ratio)	Angle (degree)	Magnitude (ratio)	Angle (degree)	Magnitude (ratio)	Angle (degree)
400	0.85	161.56	22.94	82.35	0.01	17.02	0.46	-156.50
500	0.90	159.44	11.82	82.58	0.01	27.08	0.63	176.13
600	0.90	152.15	9.98	73.86	0.01	24.10	0.64	169.61
700	0.89	145.75	8.59	66.00	0.01	21.41	0.64	164.34
800	0.88	139.33	7.55	58.86	0.02	18.47	0.65	159.29
900	0.87	133.19	6.74	51.66	0.02	14.00	0.65	154.44
1000	0.87	127.07	6.14	45.11	0.02	11.25	0.65	149.58
1100	0.87	120.67	5.61	38.20	0.02	7.99	0.65	144.25
1200	0.87	114.18	5.19	31.60	0.02	4.20	0.64	139.60
1300	0.86	107.68	4.82	25.08	0.02	0.31	0.64	134.85
1400	0.86	100.86	4.51	18.49	0.02	-4.01	0.63	130.13
1500	0.86	94.14	4.23	11.74	0.02	-8.65	0.63	125.02
1600	0.86	87.48	3.99	5.25	0.03	-13.15	0.63	120.13
1700	0.86	80.83	3.77	-1.50	0.03	-18.16	0.62	114.98
1800	0.86	74.14	3.56	-8.13	0.03	-23.28	0.62	109.78
1900	0.86	67.39	3.37	-14.94	0.03	-28.54	0.62	104.46
2000	0.86	60.70	3.19	-21.68	0.03	-33.68	0.63	99.01
2100	0.86	53.97	3.02	-28.68	0.03	-39.37	0.63	93.58
2200	0.86	47.78	2.85	-35.14	0.03	-44.84	0.63	88.17
2300	0.86	41.57	2.69	-41.70	0.03	-50.27	0.64	83.06
2400	0.86	35.43	2.54	-48.11	0.03	-55.62	0.64	78.10
2500	0.86	29.74	2.39	-54.19	0.04	-60.71	0.65	73.31
2600	0.86	24.79	2.27	-60.06	0.04	-65.48	0.65	68.64
2700	0.85	19.58	2.15	-66.14	0.04	-70.66	0.66	64.16

Table 11. Scattering parameters at 3.3 V, MMIC only $V_{CC} = 3.3\text{ V}$; $I_{CC} = 130\text{ mA}$; $T_{case} = 25\text{ }^{\circ}\text{C}$.

f (MHz)	S ₁₁		S ₂₁		S ₁₂		S ₂₂	
	Magnitude (ratio)	Angle (degree)	Magnitude (ratio)	Angle (degree)	Magnitude (ratio)	Angle (degree)	Magnitude (ratio)	Angle (degree)
400	0.84	161.94	21.25	73.81	0.01	17.66	0.57	-154.41
500	0.91	159.25	11.56	79.01	0.01	28.15	0.65	178.05
600	0.90	151.98	9.67	70.71	0.01	24.80	0.66	171.32
700	0.90	145.57	8.29	63.37	0.01	21.89	0.66	165.59
800	0.89	139.18	7.26	56.54	0.02	19.04	0.66	160.37
900	0.88	132.87	6.48	49.74	0.02	15.35	0.66	155.28
1000	0.88	126.78	5.90	43.30	0.02	11.89	0.66	150.23
1100	0.87	120.46	5.39	36.53	0.02	8.33	0.66	144.88
1200	0.87	113.94	4.97	30.05	0.02	4.50	0.65	140.03
1300	0.87	107.48	4.62	23.62	0.02	0.35	0.65	135.35
1400	0.87	100.69	4.32	17.15	0.02	-3.92	0.64	130.48
1500	0.86	93.93	4.05	10.48	0.02	-8.62	0.64	125.46
1600	0.86	87.28	3.81	4.05	0.03	-13.28	0.64	120.31
1700	0.86	80.71	3.61	-2.66	0.03	-18.26	0.64	115.13
1800	0.86	74.00	3.40	-9.21	0.03	-23.51	0.64	109.99
1900	0.86	67.27	3.22	-15.97	0.03	-28.87	0.63	104.66
2000	0.86	60.64	3.05	-22.71	0.03	-34.22	0.64	99.36
2100	0.86	53.84	2.89	-29.68	0.03	-39.95	0.64	93.93
2200	0.86	47.60	2.72	-36.12	0.03	-45.44	0.64	88.55
2300	0.86	41.43	2.57	-42.66	0.03	-51.06	0.65	83.38
2400	0.86	35.35	2.42	-49.01	0.04	-56.53	0.65	78.44
2500	0.85	29.64	2.28	-55.12	0.04	-61.72	0.66	73.56
2600	0.85	24.72	2.16	-60.91	0.04	-66.76	0.66	68.80
2700	0.85	19.59	2.04	-66.91	0.04	-71.84	0.67	64.30

10. Reliability information

Table 12. Reliability

Life test	Conditions	Intrinsic failure rate
HTOL	According JESD85; confidence level 60 %; $T_j = 55\text{ }^{\circ}\text{C}$; activation energy = 0.7 eV; acceleration factor determined according Arrhenius	4

11. Moisture sensitivity

Table 13. Moisture sensitivity level

Test methodology	Class
JESD-22-A113	1

12. Application information

12.1 5 V applications

12.1.1 920 MHz to 960 MHz

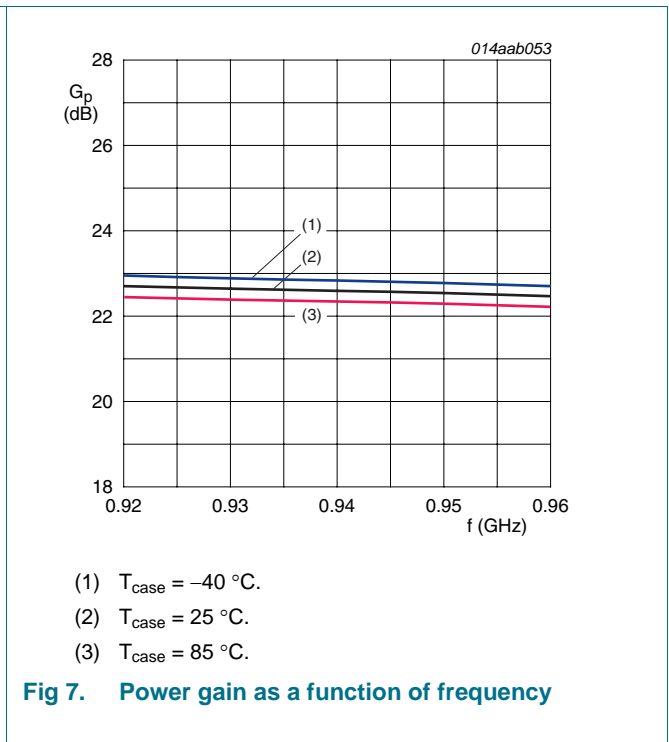
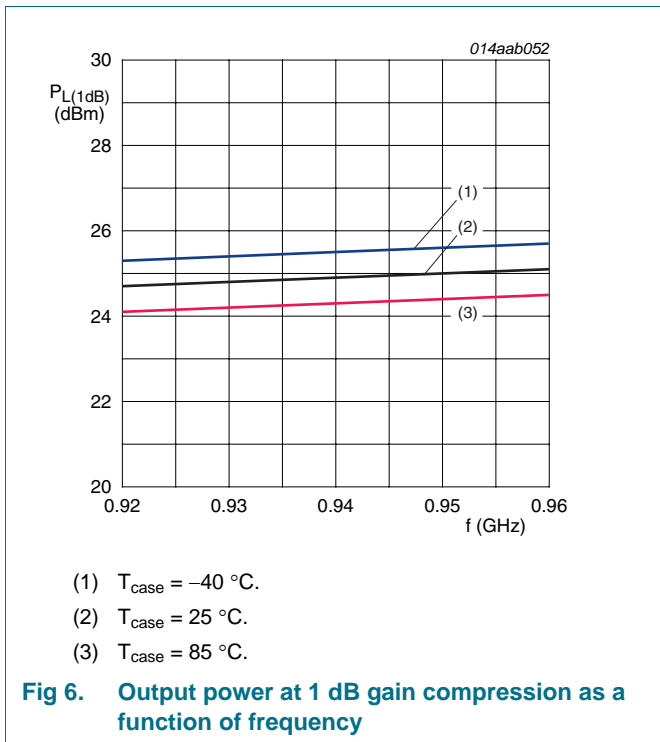
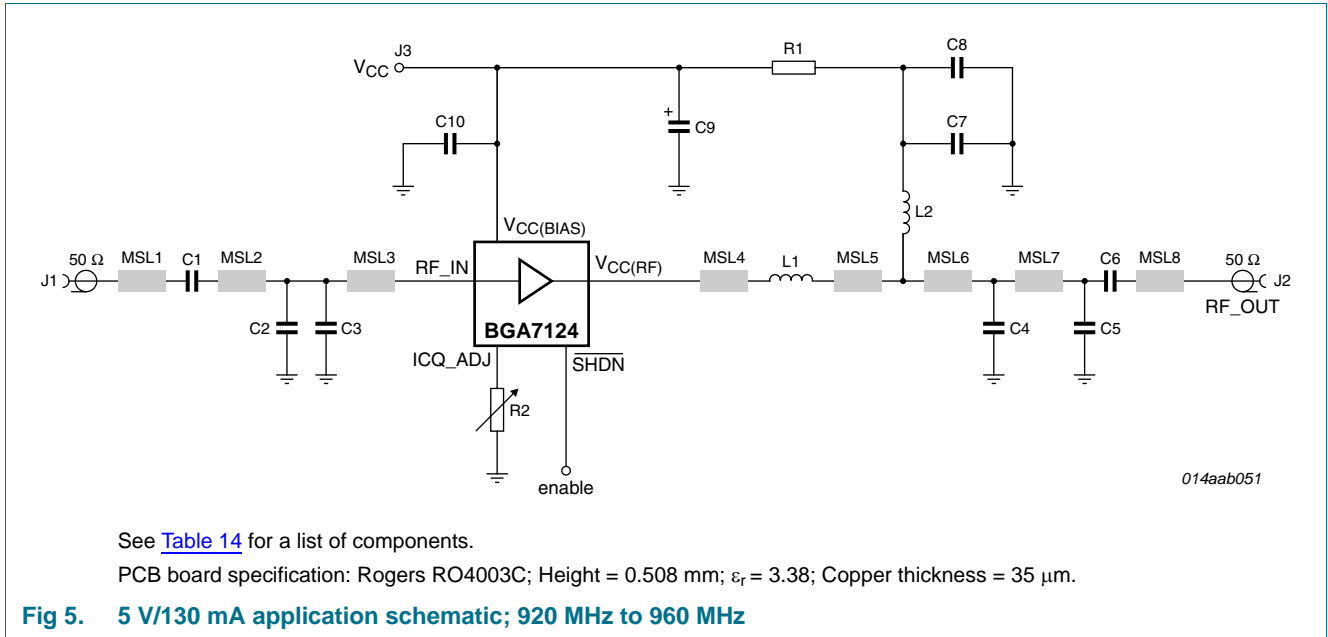

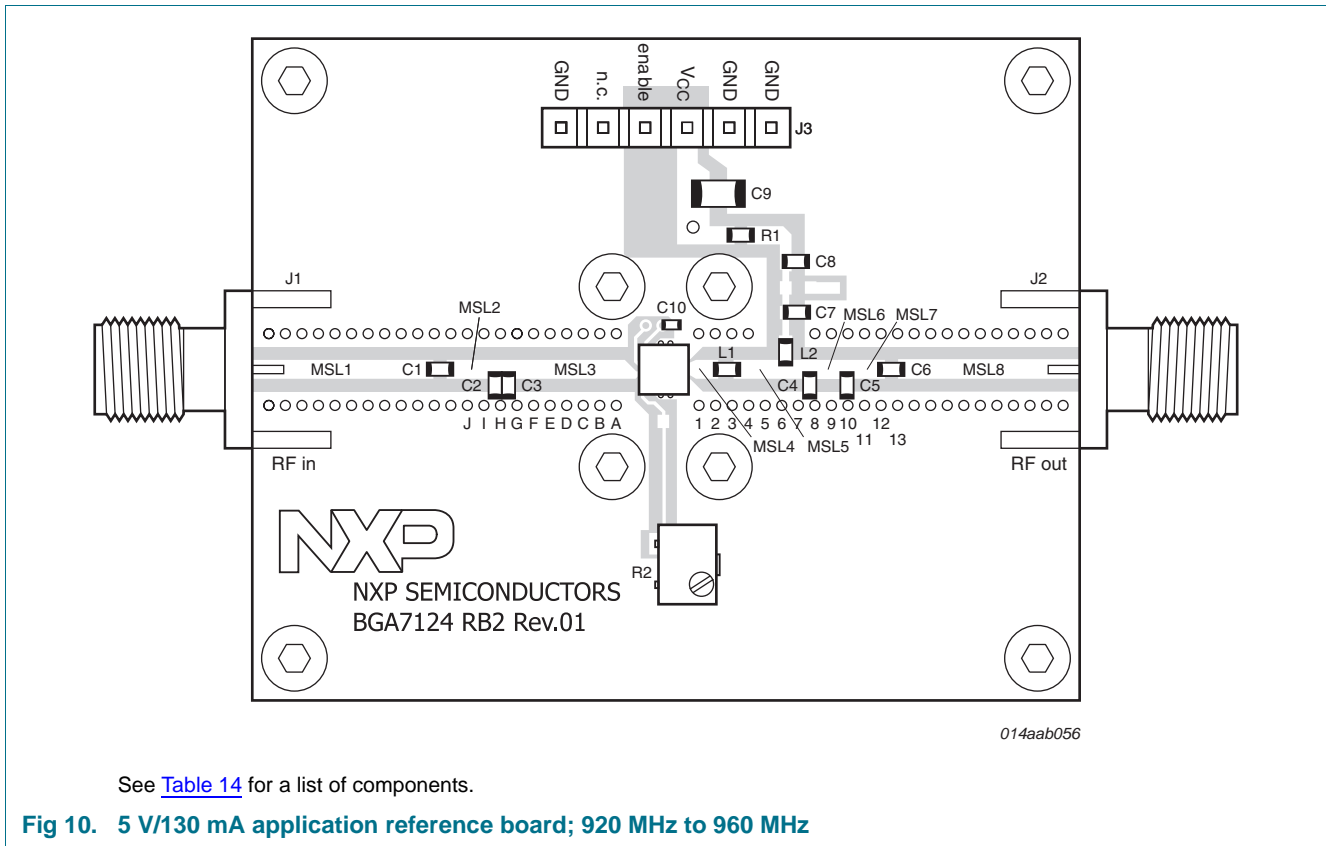
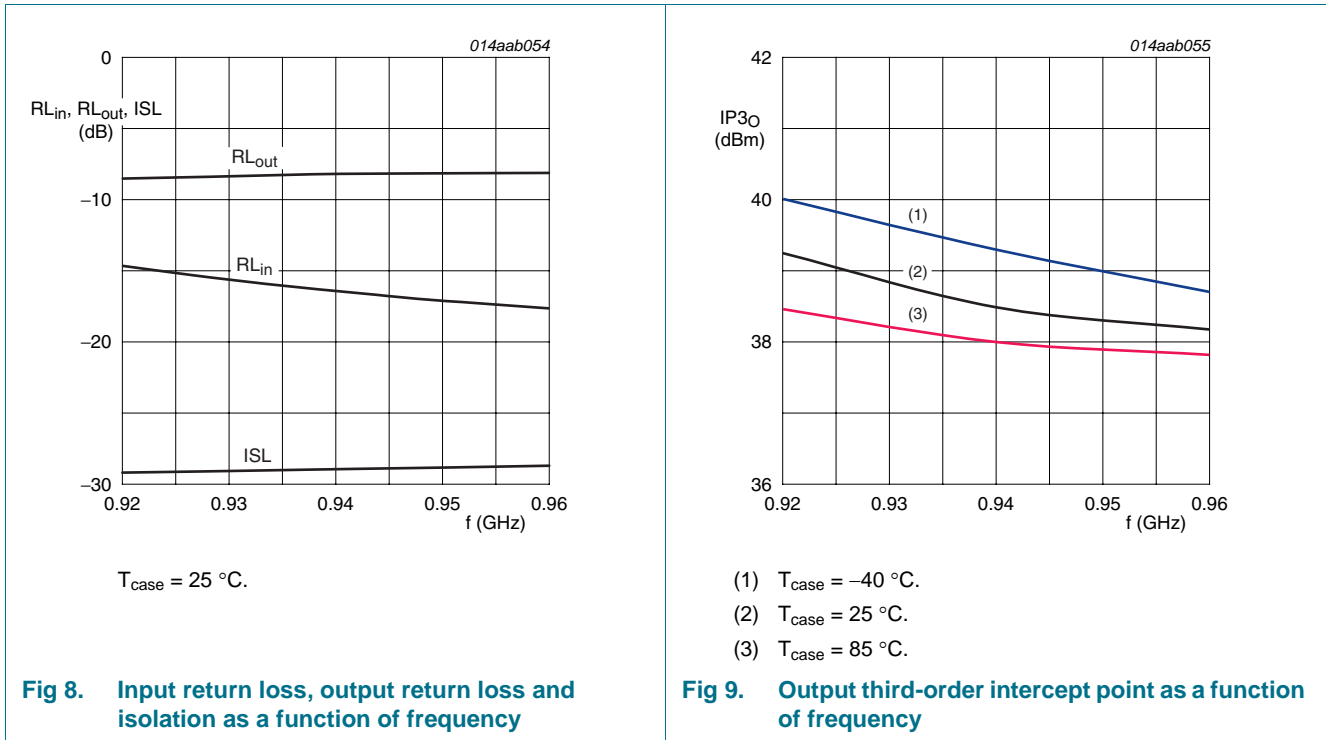

Table 14. 5 V/130 mA application list of components; 920 MHz to 960 MHz

See [Figure 5](#) and [Figure 10](#) for component layout. Printed-Circuit Board (PCB): Rogers RO4003C stack; height = 0.508 mm; copper plating thickness = 35 μm .

Component	Description	Value	Function	Remarks
C1, C6	capacitor	68 pF	DC blocking	Murata GRM1885C1H680JA01D
C2, C3	capacitor	3.3 pF	input match	Murata GRM1885C1H3R3CZ01D
C4	capacitor	3.9 pF	output match	Murata GRM1885C1H3R9CZ01D
C5	capacitor	1.0 pF	output match	Murata GRM1885C1H1R0CZ01D
C7	capacitor	68 pF	RF decoupling	Murata GRM1885C1H680JA01D
C8	capacitor	100 nF	DC decoupling	AVX 0603YC104KAT2A
C9	capacitor	10 μF	DC decoupling	AVX 1206ZG106ZAT2A
C10	capacitor	12 pF	noise decoupling	Murata GRM1555C1H120JZ01D
J1, J2	RF connector	SMA		Emerson Network Power 142-0701-841
J3	DC connector	6-pins		MOLEX
L1	inductor	2.2 nH	output match	Tyco electronics 36501J2N2JTDG
L2	inductor	22 nH	DC feed	Tyco electronics 36501J022JTDG
MSL1 ^[1]	micro stripline	1.14 mm \times 0.8 mm \times 10.95 mm	input match	
MSL2 ^[1]	micro stripline	1.14 mm \times 0.8 mm \times 2.95 mm	input match	
MSL3 ^[1]	micro stripline	1.14 mm \times 0.8 mm \times 7.75 mm	input match	
MSL4 ^[1]	micro stripline	1.14 mm \times 0.8 mm \times 23.4 mm	output match	
MSL5 ^[1]	micro stripline	1.14 mm \times 0.8 mm \times 2.2 mm	output match	
MSL6 ^[1]	micro stripline	1.14 mm \times 0.8 mm \times 3.15 mm	output match	
MSL7 ^[1]	micro stripline	1.14 mm \times 0.8 mm \times 2.3 mm	output match	
MSL8 ^[1]	micro stripline	1.14 mm \times 0.8 mm \times 10.95 mm	output match	
R1	resistor	0 Ω		Multicomp MC 0.063W 0603 0R
R2	resistor (trimmer)	2 k Ω	bias adjustment	Bourns 3214W-1-202E

[1] MSL1 to MSL8 dimensions specified as Width (W), Spacing (S) and Length (L).

12.1.2 1930 MHz to 1990 MHz

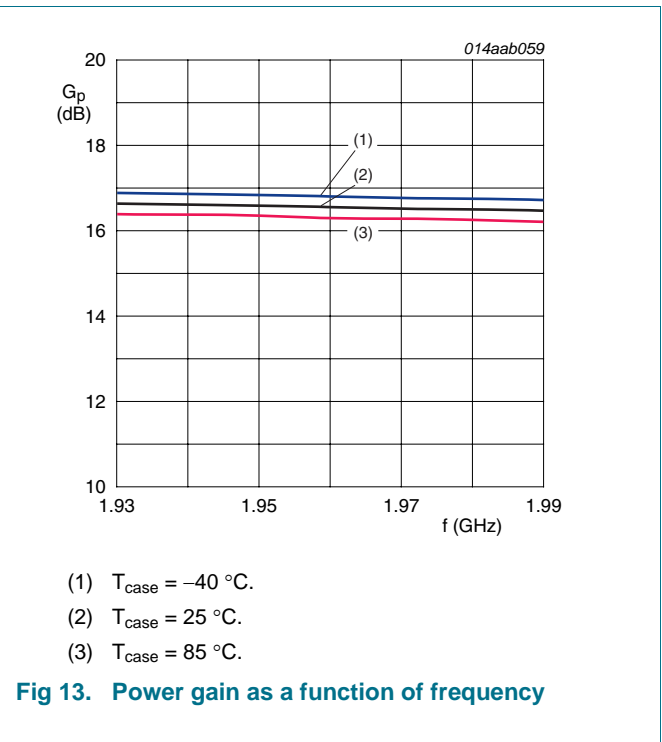
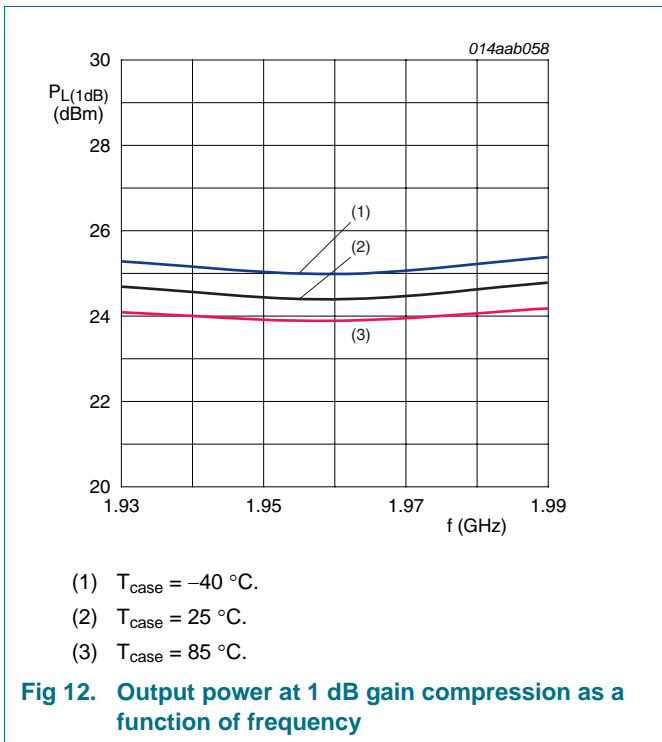
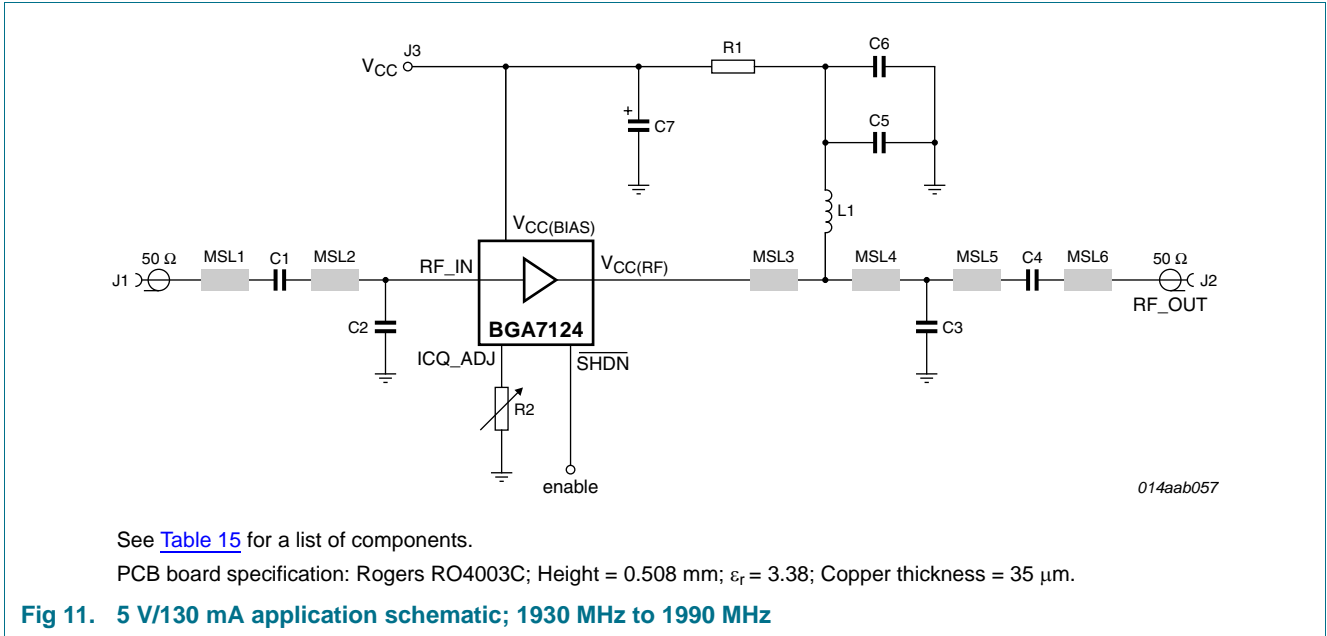

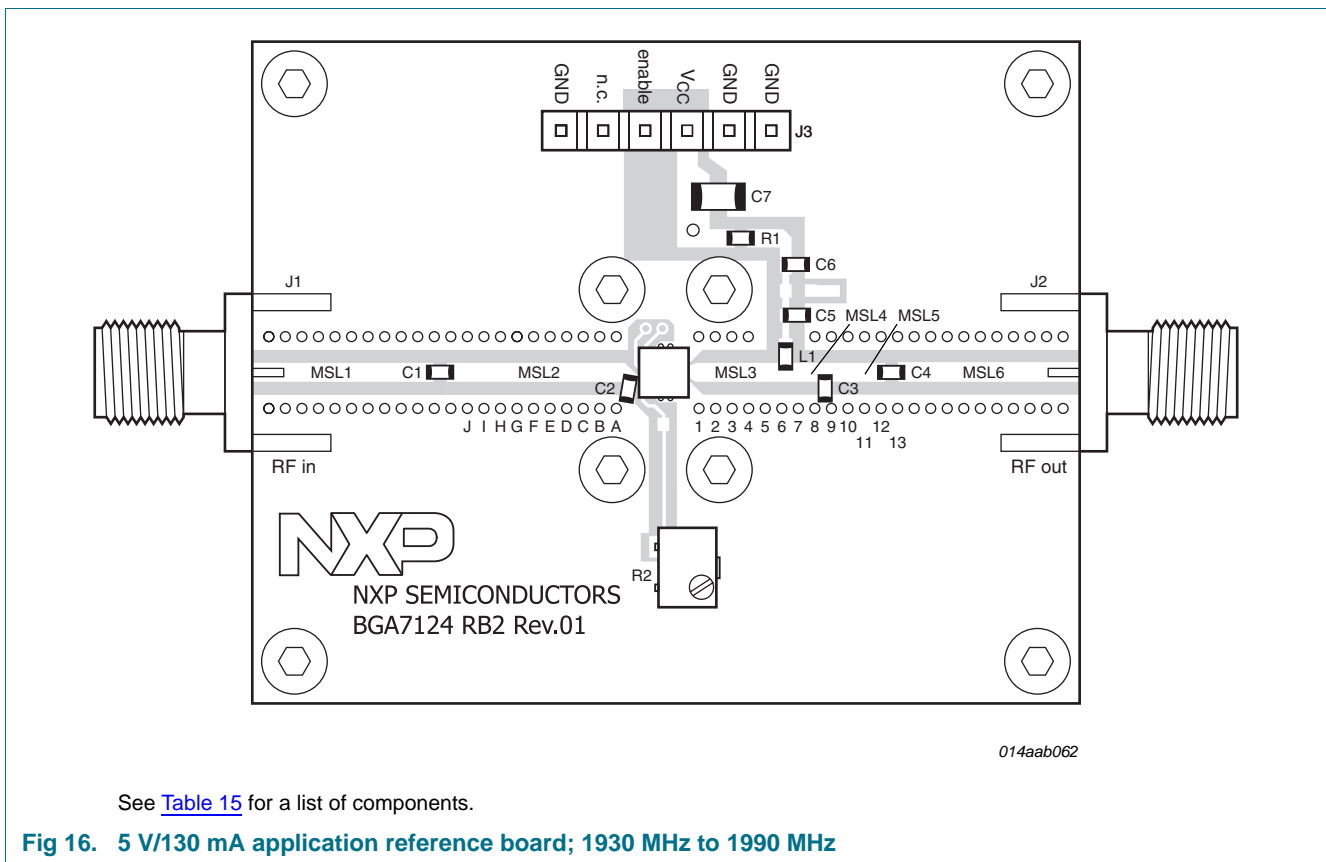
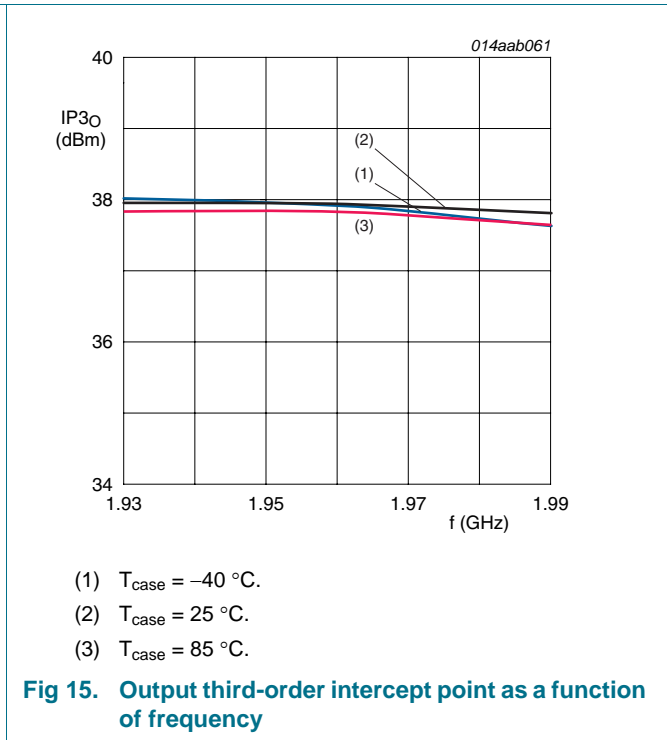
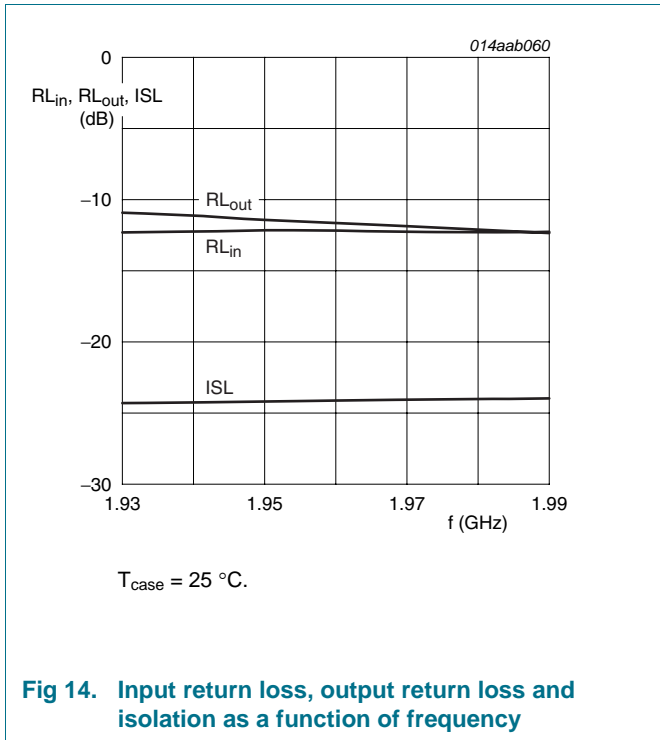

Table 15. 5 V/130 mA application list of components; 1930 MHz to 1990 MHz

See [Figure 11](#) and [Figure 16](#) for component layout. Printed-Circuit Board (PCB): Rogers RO4003C stack; height = 0.508 mm; copper plating thickness = 35 μm.

Component	Description	Value	Function	Remarks
C1, C4	capacitor	15 pF	DC blocking	Murata GRM1885C1H150JA01D
C2	capacitor	2.2 pF	input match	Murata GRM1885C1H2R2CZ01D
C3	capacitor	1.2 pF	output match	Murata GRM1885C1H1R2CZ01D
C5	capacitor	15 pF	RF decoupling	Murata GRM1885C1H150JA01D
C6	capacitor	100 nF	DC decoupling	AVX 0603YC104KAT2A
C7	capacitor	10 μF	DC decoupling	AVX 1206ZG106ZAT2A
J1, J2	RF connector	SMA		Emerson Network Power 142-0701-841
J3	DC connector	6-pins		MOLEX
L1	inductor	22 nH	DC feed	Tyco electronics 36501J022JTDG
MSL1 ^[1]	micro stripline	1.14 mm × 0.8 mm × 10.95 mm	input match	
MSL2 ^[1]	micro stripline	1.14 mm × 0.8 mm × 10.8 mm	input match	
MSL3 ^[1]	micro stripline	1.14 mm × 0.8 mm × 5.8 mm	output match	
MSL4 ^[1]	micro stripline	1.14 mm × 0.8 mm × 2.2 mm	output match	
MSL5 ^[1]	micro stripline	1.14 mm × 0.8 mm × 3.7 mm	output match	
MSL6 ^[1]	micro stripline	1.14 mm × 0.8 mm × 10.95 mm	output match	
R1	resistor	0 Ω		Multicomp MC 0.063W 0603 0R
R2	resistor (trimmer)	2 kΩ	bias adjustment	Bourns 3214W-1-202E

[1] MSL1 to MSL6 dimensions specified as Width (W), Spacing (S) and Length (L).

12.1.3 2110 MHz to 2170 MHz

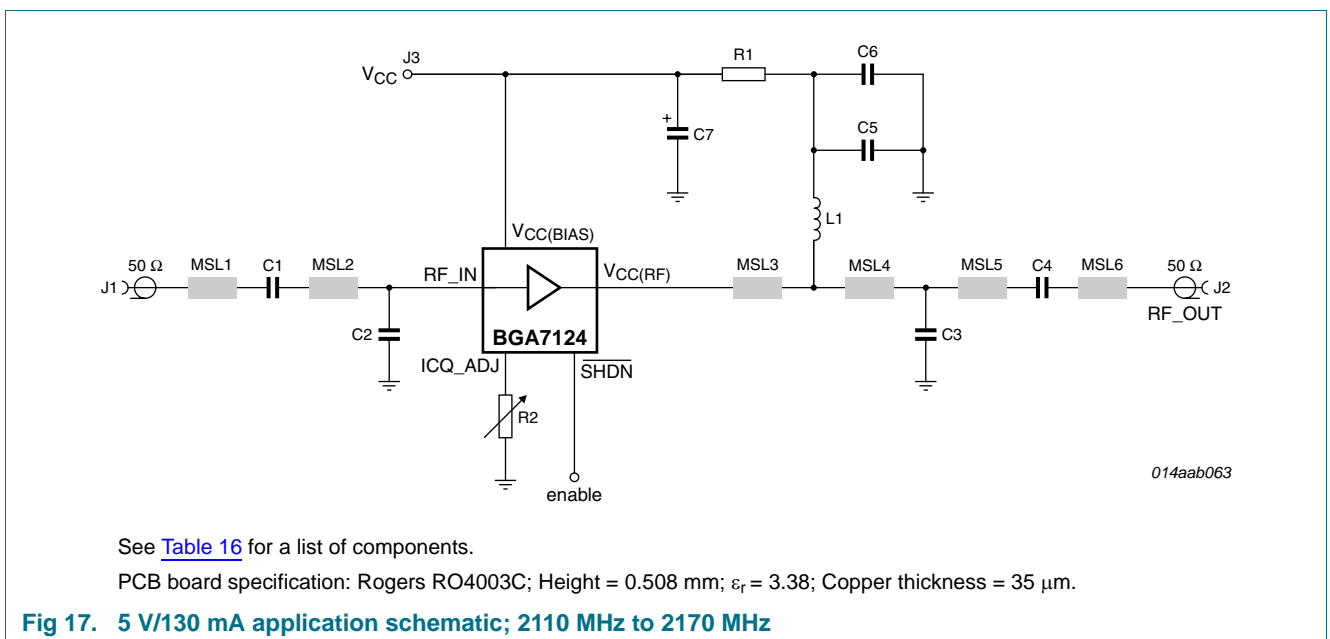

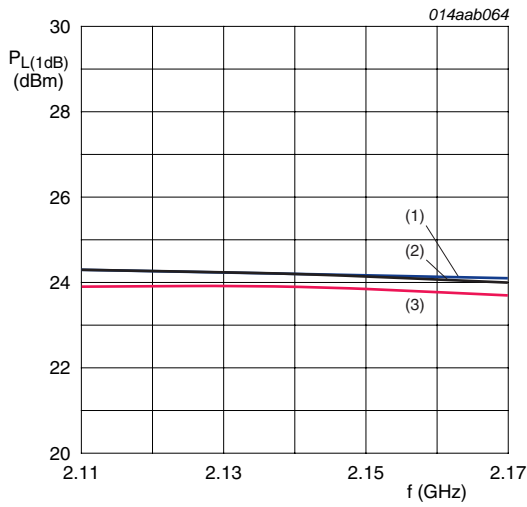

- (1) $T_{case} = -40\text{ }^{\circ}\text{C}$.
- (2) $T_{case} = 25\text{ }^{\circ}\text{C}$.
- (3) $T_{case} = 85\text{ }^{\circ}\text{C}$.

Fig 18. Output power at 1 dB gain compression as a function of frequency

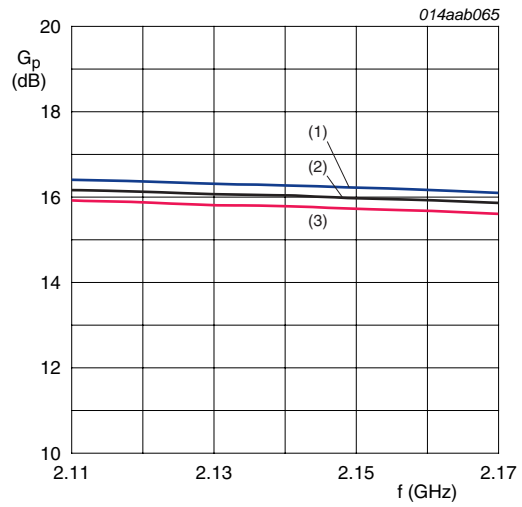

- (1) $T_{case} = -40\text{ }^{\circ}\text{C}$.
- (2) $T_{case} = 25\text{ }^{\circ}\text{C}$.
- (3) $T_{case} = 85\text{ }^{\circ}\text{C}$.

Fig 19. Power gain as a function of frequency

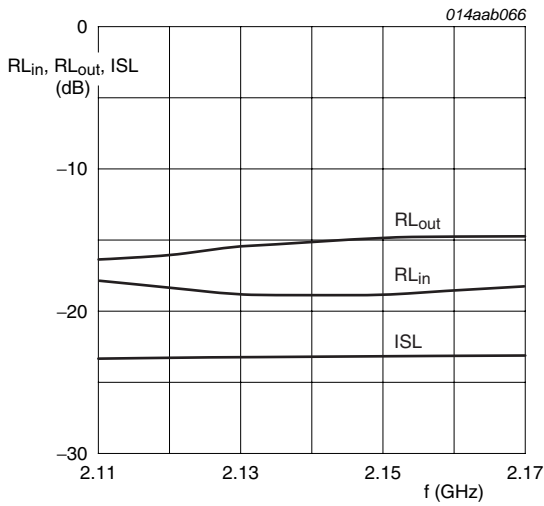

$T_{case} = 25\text{ }^{\circ}\text{C}$.

Fig 20. Input return loss, output return loss and isolation as a function of frequency

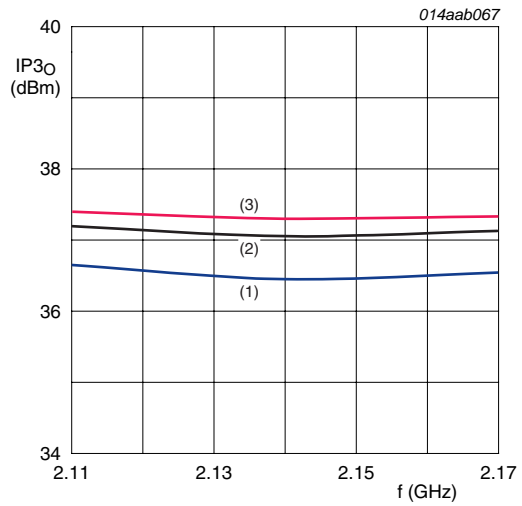

- (1) $T_{case} = -40\text{ }^{\circ}\text{C}$.
- (2) $T_{case} = 25\text{ }^{\circ}\text{C}$.
- (3) $T_{case} = 85\text{ }^{\circ}\text{C}$.

Fig 21. Output third-order intercept point as a function of frequency

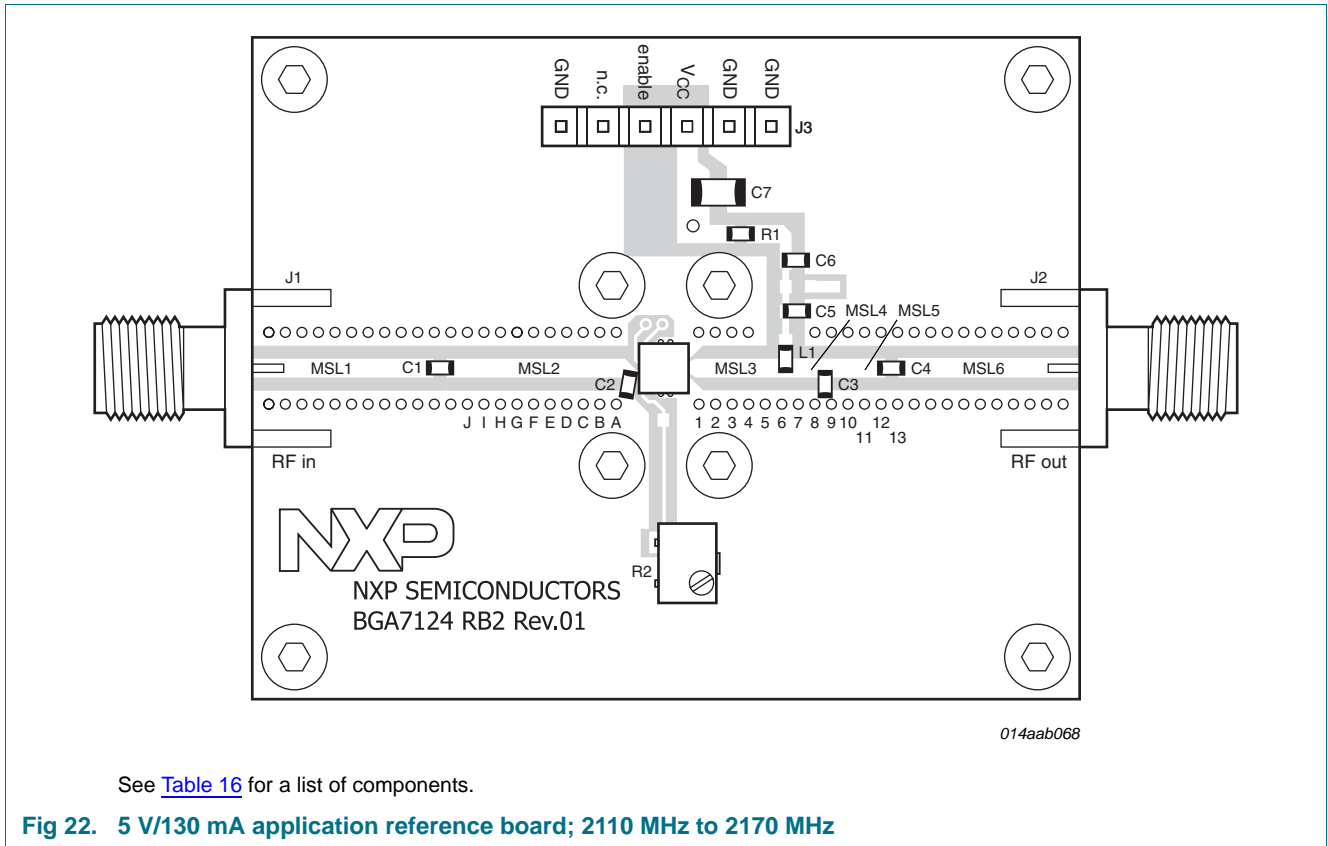

Table 16. 5 V/130 mA application list of components; 2110 MHz to 2170 MHz

See [Figure 17](#) and [Figure 22](#) for component layout. Printed-Circuit Board (PCB): Rogers RO4003C stack; height = 0.508 mm; copper plating thickness = 35 μm.

Component	Description	Value	Function	Remarks
C1, C4	capacitor	15 pF	DC blocking	Murata GRM1885C1H150JA01D
C2	capacitor	2.7 pF	input match	Murata GRM1885C1H2R7CZ01D
C3	capacitor	1.5 pF	output match	Murata GRM1885C1H1R5CZ01D
C5	capacitor	15 pF	RF decoupling	Murata GRM1885C1H150JA01D
C6	capacitor	100 nF	DC decoupling	AVX 0603YC104KAT2A
C7	capacitor	10 μF	DC decoupling	AVX 1206ZG106ZAT2A
J1, J2	RF connector	SMA		Emerson Network Power 142-0701-841
J3	DC connector	6-pins		MOLEX
L1	inductor	22 nH	DC feed	Tyco electronics 36501J022JTDG
MSL1 ^[1]	micro stripline	1.14 mm × 0.8 mm × 10.95 mm	input match	
MSL2 ^[1]	micro stripline	1.14 mm × 0.8 mm × 10.8 mm	input match	
MSL3 ^[1]	micro stripline	1.14 mm × 0.8 mm × 5.8 mm	output match	
MSL4 ^[1]	micro stripline	1.14 mm × 0.8 mm × 2.5 mm	output match	
MSL5 ^[1]	micro stripline	1.14 mm × 0.8 mm × 3.5 mm	output match	

Table 16. 5 V/130 mA application list of components; 2110 MHz to 2170 MHz ...continued

See [Figure 17](#) and [Figure 22](#) for component layout. Printed-Circuit Board (PCB): Rogers RO4003C stack; height = 0.508 mm; copper plating thickness = 35 μm.

Component	Description	Value	Function	Remarks
MSL6 ^[1]	micro stripline	1.14 mm × 0.8 mm × 10.95 mm	output match	
R1	resistor	0 Ω		Multicomp MC 0.063W 0603 0R
R2	resistor (trimmer)	2 kΩ	bias adjustment	Bourns 3214W-1-202E

[1] MSL1 to MSL6 dimensions specified as Width (W), Spacing (S) and Length (L).

12.1.4 2405 MHz to 2485 MHz

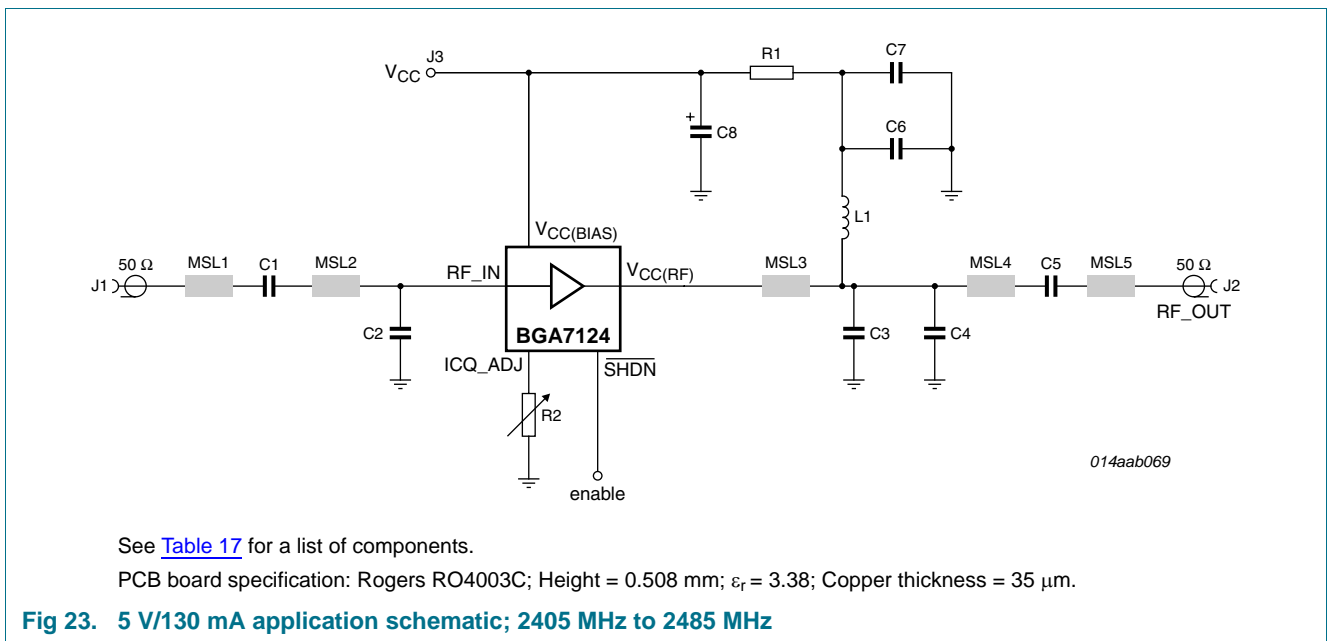

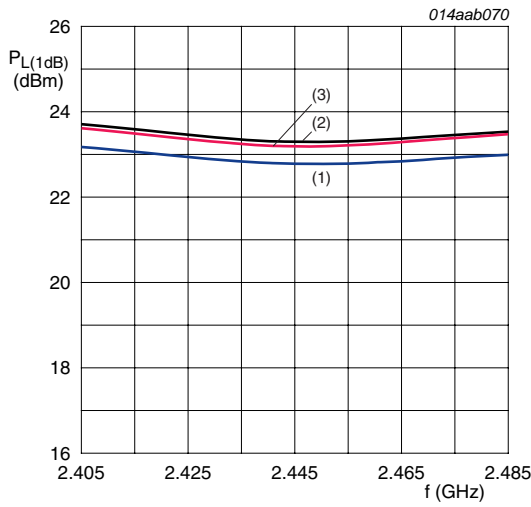

- (1) T_{case} = -40 °C.
- (2) T_{case} = 25 °C.
- (3) T_{case} = 85 °C.

Fig 24. Output power at 1 dB gain compression as a function of frequency

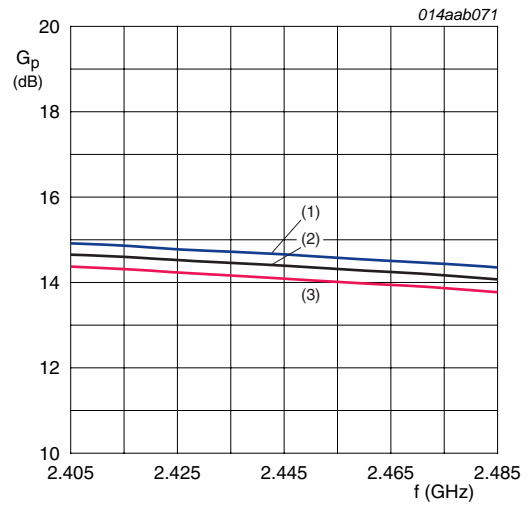

- (1) T_{case} = -40 °C.
- (2) T_{case} = 25 °C.
- (3) T_{case} = 85 °C.

Fig 25. Power gain as a function of frequency

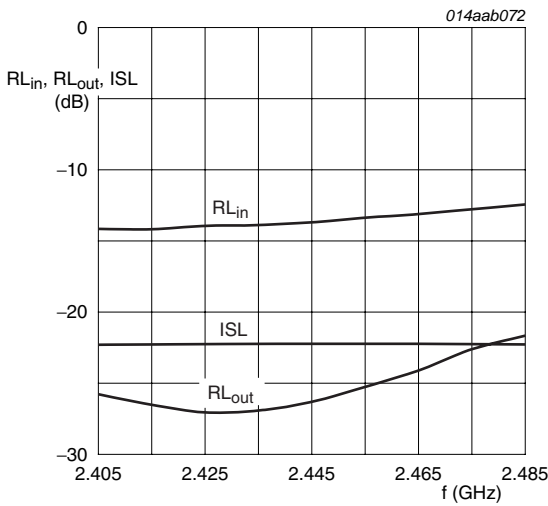

T_{case} = 25 °C.

Fig 26. Input return loss, output return loss and isolation as a function of frequency

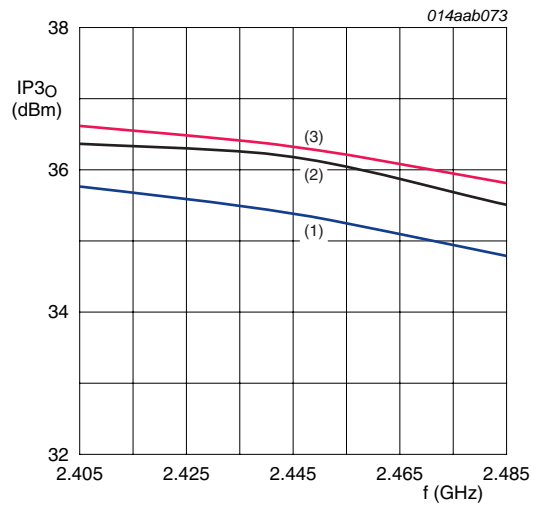

- (1) T_{case} = -40 °C.
- (2) T_{case} = 25 °C.
- (3) T_{case} = 85 °C.

Fig 27. Output third-order intercept point as a function of frequency

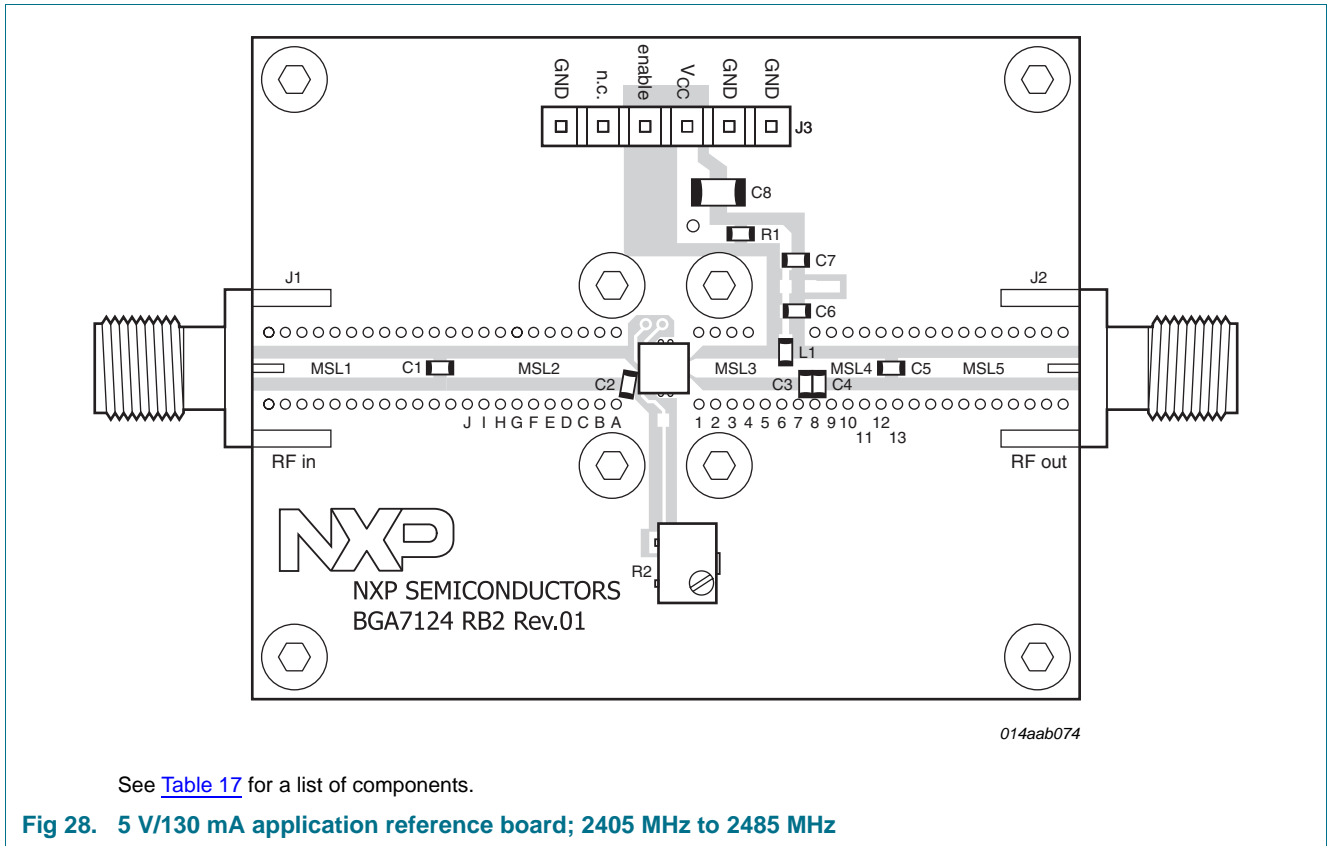

Table 17. 5 V/130 mA application list of components; 2405 MHz to 2485 MHz

See [Figure 23](#) and [Figure 28](#) for component layout. Printed-Circuit Board (PCB): Rogers RO4003C stack; height = 0.508 mm; copper plating thickness = 35 μm.

Component	Description	Value	Function	Remarks
C1, C5	capacitor	12 pF	DC blocking	Murata GRM1885C1H120JA01D
C2	capacitor	2.2 pF	input match	Murata GRM1885C1H2R2CZ01D
C3	capacitor	0.82 pF	output match	Murata GRM1885C1HR82CZ01D
C4	capacitor	0.68 pF	output match	Murata GRM1885C1HR68CZ01D
C6	capacitor	12 pF	RF decoupling	Murata GRM1885C1H120JA01D
C7	capacitor	100 nF	DC decoupling	AVX 0603YC104KAT2A
C8	capacitor	10 μF	DC decoupling	AVX 1206ZG106ZAT2A
J1, J2	RF connector	SMA		Emerson Network Power 142-0701-841
J3	DC connector	6-pins		MOLEX
L1	inductor	22 nH	DC feed	Tyco electronics 36501J022JTDG
MSL1 ^[1]	micro stripline	1.14 mm × 0.8 mm × 10.95 mm	input match	
MSL2 ^[1]	micro stripline	1.14 mm × 0.8 mm × 10.8 mm	input match	
MSL3 ^[1]	micro stripline	1.14 mm × 0.8 mm × 7.3 mm	output match	
MSL4 ^[1]	micro stripline	1.14 mm × 0.8 mm × 4.3 mm	output match	

Table 17. 5 V/130 mA application list of components; 2405 MHz to 2485 MHz ...continued

See [Figure 23](#) and [Figure 28](#) for component layout. Printed-Circuit Board (PCB): Rogers RO4003C stack; height = 0.508 mm; copper plating thickness = 35 μm.

Component	Description	Value	Function	Remarks
MSL5 ^[1]	micro stripline	1.14 mm × 0.8 mm × 10.95 mm	output match	
R1	resistor	2.2 Ω		Multicomp MC 0.063W 0603 2R2
R2	resistor (trimmer)	2 kΩ	bias adjustment	Bourns 3214W-1-202E

[1] MSL1 to MSL5 dimensions specified as Width (W), Spacing (S) and Length (L).

12.2 3.3 V applications

12.2.1 920 MHz to 960 MHz

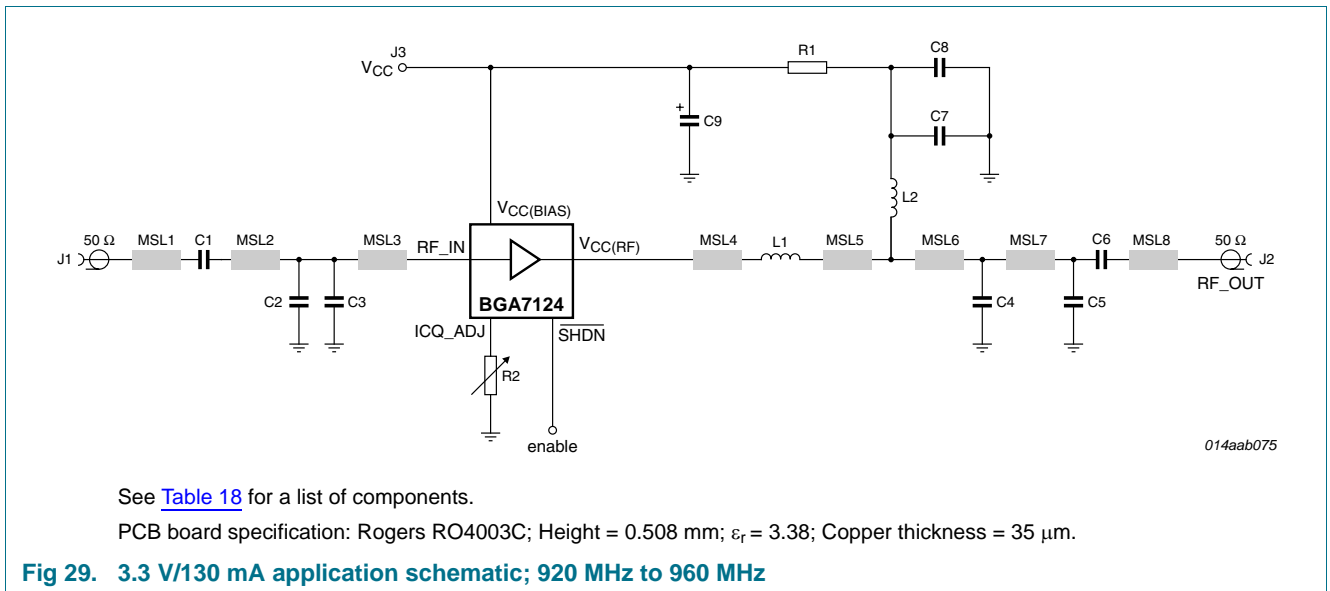

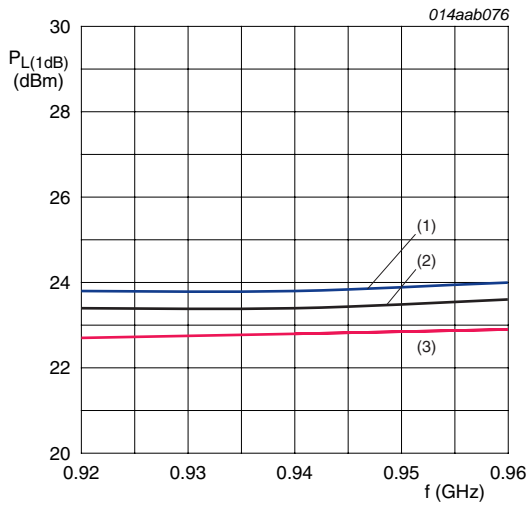

- (1) $T_{case} = -40\text{ }^{\circ}\text{C}$.
- (2) $T_{case} = 25\text{ }^{\circ}\text{C}$.
- (3) $T_{case} = 85\text{ }^{\circ}\text{C}$.

Fig 30. Output power at 1 dB gain compression as a function of frequency

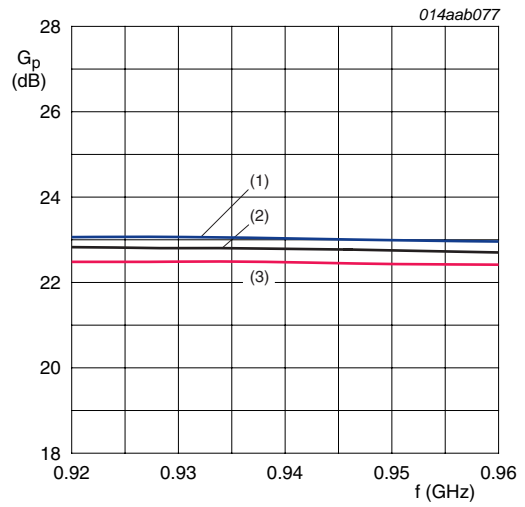

- (1) $T_{case} = -40\text{ }^{\circ}\text{C}$.
- (2) $T_{case} = 25\text{ }^{\circ}\text{C}$.
- (3) $T_{case} = 85\text{ }^{\circ}\text{C}$.

Fig 31. Power gain as a function of frequency

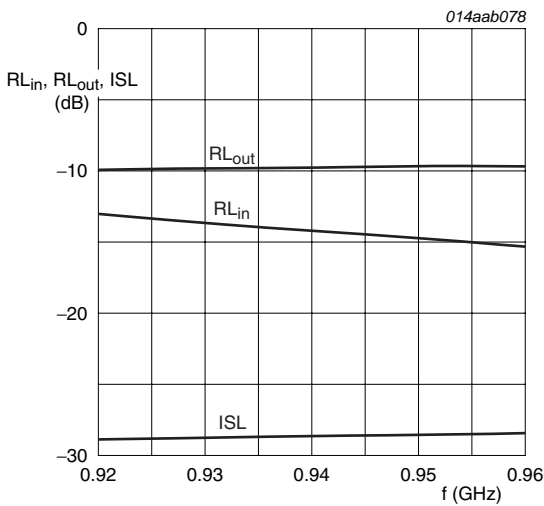

$T_{case} = 25\text{ }^{\circ}\text{C}$.

Fig 32. Input return loss, output return loss and isolation as a function of frequency

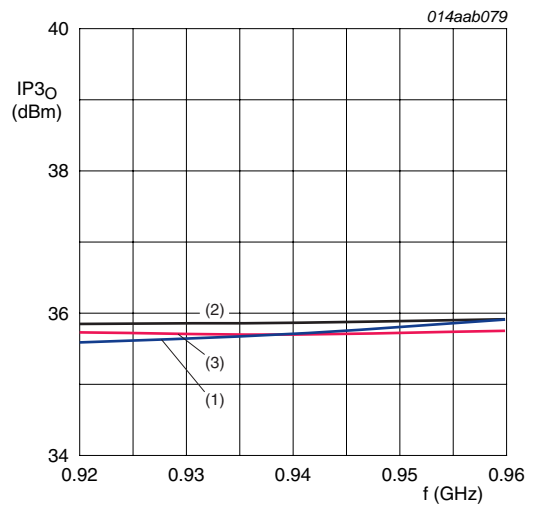

- (1) $T_{case} = -40\text{ }^{\circ}\text{C}$.
- (2) $T_{case} = 25\text{ }^{\circ}\text{C}$.
- (3) $T_{case} = 85\text{ }^{\circ}\text{C}$.

Fig 33. Output third-order intercept point as a function of frequency

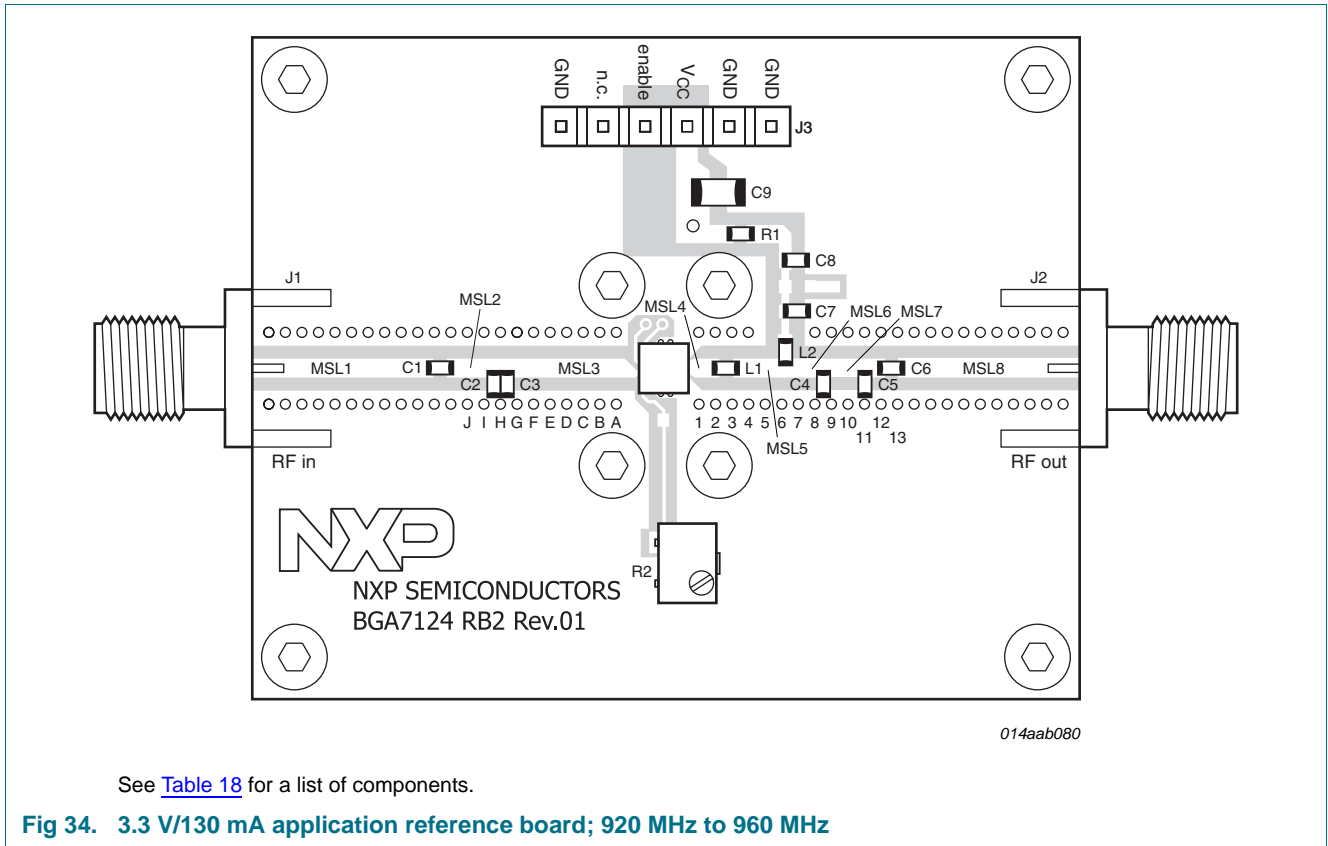

Table 18. 3.3 V/130 mA application list of components; 920 MHz to 960 MHz

See [Figure 29](#) and [Figure 34](#) for component layout. Printed-Circuit Board (PCB): Rogers RO4003C stack; height = 0.508 mm; copper plating thickness = 35 μm.

Component	Description	Value	Function	Remarks
C1, C6	capacitor	68 pF	DC blocking	Murata GRM1885C1H680JA01D
C2, C3	capacitor	3.3 pF	input match	Murata GRM1885C1H3R3CZ01D
C4	capacitor	3.9 pF	output match	Murata GRM1885C1H3R9CZ01D
C5	capacitor	1.0 pF	output match	Murata GRM1885C1H1R0CZ01D
C7	capacitor	68 pF	RF decoupling	Murata GRM1885C1H680JA01D
C8	capacitor	100 nF	DC decoupling	AVX 0603YC104KAT2A
C9	capacitor	10 μF	DC decoupling	AVX 1206ZG106ZAT2A
J1, J2	RF connector	SMA		Emerson Network Power 142-0701-841
J3	DC connector	6-pins		MOLEX
L1	inductor	2.2 nH	output match	Tyco electronics 36501J2N2JTDG
L2	inductor	22 nH	DC feed	Tyco electronics 36501J022JTDG
MSL1 ^[1]	micro stripline	1.14 mm × 0.8 mm × 10.95 mm	input match	
MSL2 ^[1]	micro stripline	1.14 mm × 0.8 mm × 2.95 mm	input match	
MSL3 ^[1]	micro stripline	1.14 mm × 0.8 mm × 7.75 mm	input match	
MSL4 ^[1]	micro stripline	1.14 mm × 0.8 mm × 23.4 mm	output match	
MSL5 ^[1]	micro stripline	1.14 mm × 0.8 mm × 2.2 mm	output match	

Table 18. 3.3 V/130 mA application list of components; 920 MHz to 960 MHz ...continued

See [Figure 29](#) and [Figure 34](#) for component layout. Printed-Circuit Board (PCB): Rogers RO4003C stack; height = 0.508 mm; copper plating thickness = 35 μm.

Component	Description	Value	Function	Remarks
MSL6 ^[1]	micro stripline	1.14 mm × 0.8 mm × 2.4 mm	output match	
MSL7 ^[1]	micro stripline	1.14 mm × 0.8 mm × 2.3 mm	output match	
MSL8 ^[1]	micro stripline	1.14 mm × 0.8 mm × 10.95 mm	output match	
R1	resistor	0 Ω		Multicomp MC 0.063W 0603 0R
R2	resistor (trimmer)	2 kΩ	bias adjustment	Bourns 3214W-1-202E

[1] MSL1 to MSL8 dimensions specified as Width (W), Spacing (S) and Length (L).

12.2.2 2405 MHz to 2485 MHz

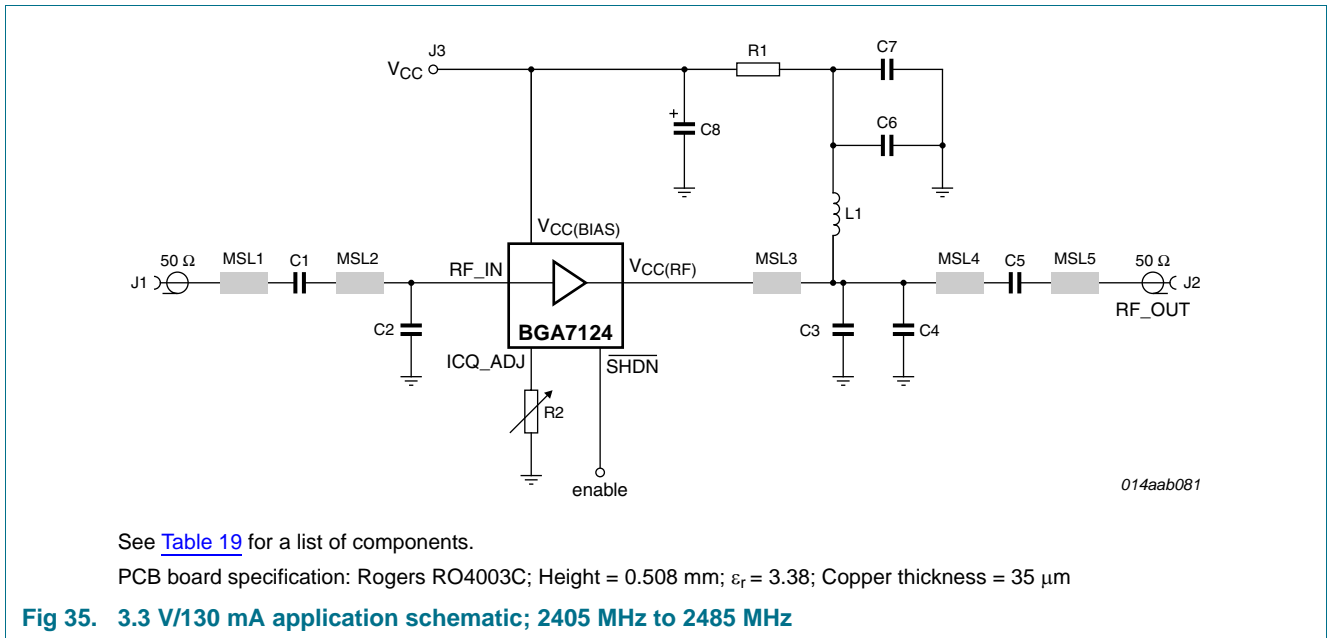

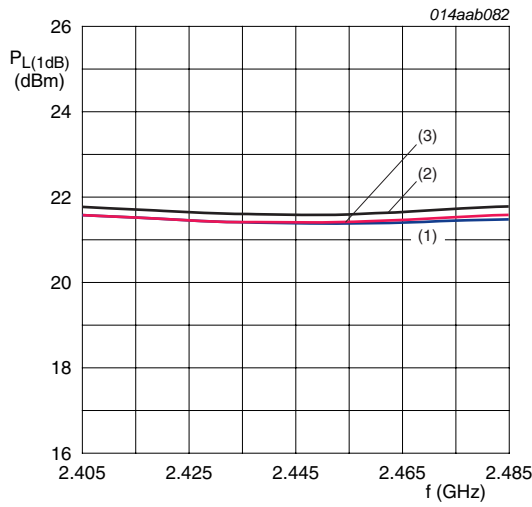

- (1) $T_{case} = -40\text{ }^{\circ}\text{C}$.
- (2) $T_{case} = 25\text{ }^{\circ}\text{C}$.
- (3) $T_{case} = 85\text{ }^{\circ}\text{C}$.

Fig 36. Output power at 1 dB gain compression as a function of frequency

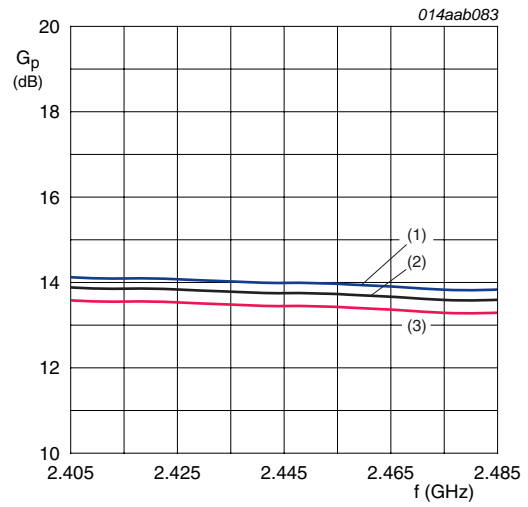

- (1) $T_{case} = -40\text{ }^{\circ}\text{C}$.
- (2) $T_{case} = 25\text{ }^{\circ}\text{C}$.
- (3) $T_{case} = 85\text{ }^{\circ}\text{C}$.

Fig 37. Power gain as a function of frequency

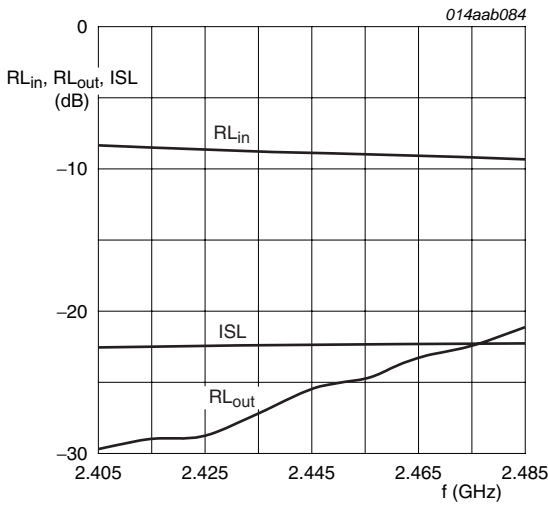

$T_{case} = 25\text{ }^{\circ}\text{C}$.

Fig 38. Input return loss, output return loss and isolation as a function of frequency

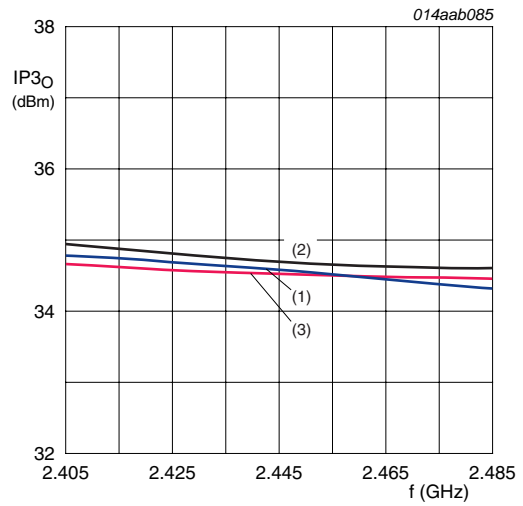

- (1) $T_{case} = -40\text{ }^{\circ}\text{C}$.
- (2) $T_{case} = 25\text{ }^{\circ}\text{C}$.
- (3) $T_{case} = 85\text{ }^{\circ}\text{C}$.

Fig 39. Output third-order intercept point as a function of frequency

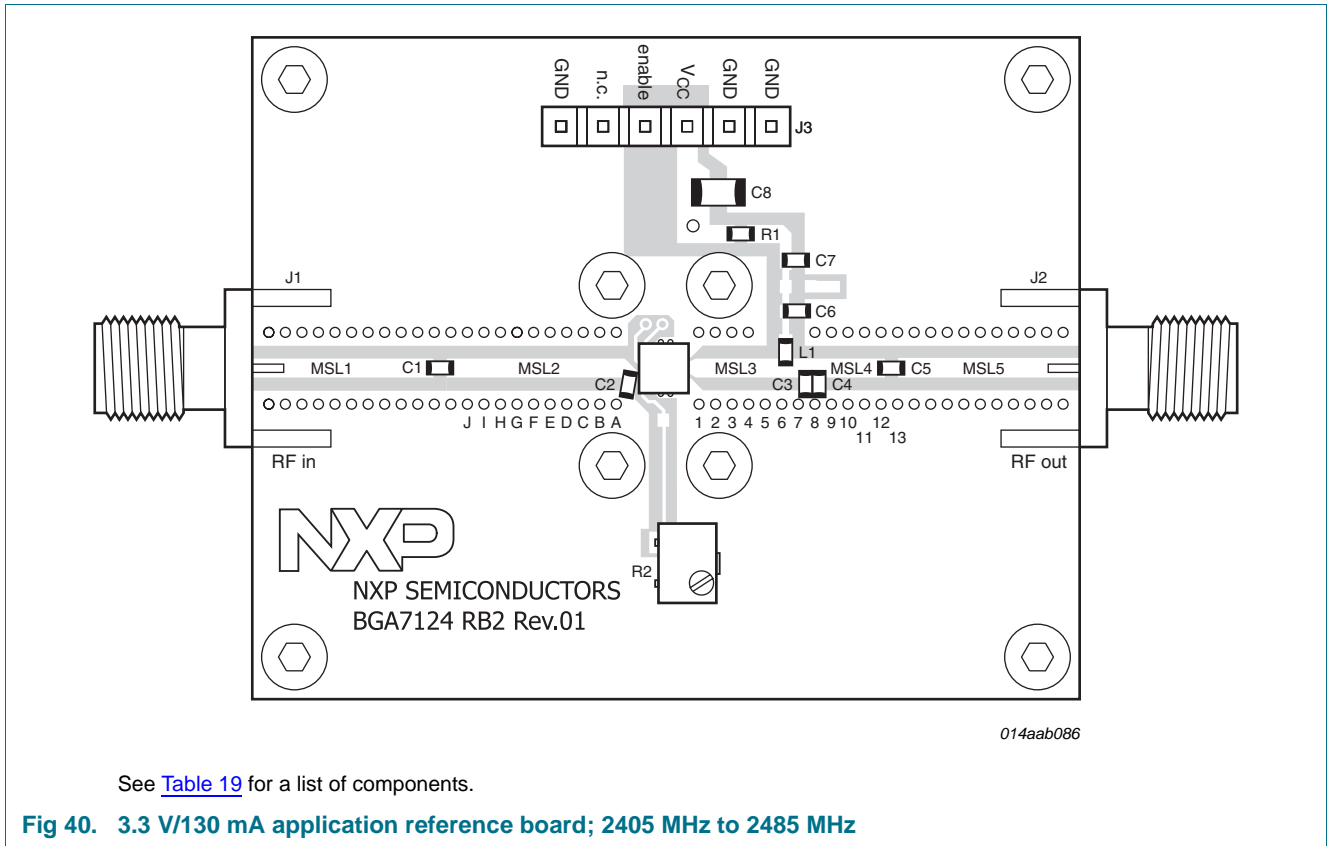

Table 19. 3.3 V/130 mA application list of components; 2405 MHz to 2485 MHz

See [Figure 35](#) and [Figure 40](#) for component layout. Printed-Circuit Board (PCB): Rogers RO4003C stack; height = 0.508 mm; copper plating thickness = 35 μm.

Component	Description	Value	Function	Remarks
C1, C5	capacitor	12 pF	DC blocking	Murata GRM1885C1H120JA01D
C2	capacitor	2.2 pF	input match	Murata GRM1885C1H2R2CZ01D
C3	capacitor	0.82 pF	output match	Murata GRM1885C1HR82CZ01D
C4	capacitor	0.68 pF	output match	Murata GRM1885C1HR68CZ01D
C6	capacitor	12 pF	RF decoupling	Murata GRM1885C1H120JA01D
C7	capacitor	100 nF	DC decoupling	AVX 0603YC104KAT2A
C8	capacitor	10 μF	DC decoupling	AVX 1206ZG106ZAT2A
J1, J2	RF connector	SMA		Emerson Network Power 142-0701-841
J3	DC connector	6-pins		MOLEX
L1	inductor	22 nH	DC feed	Tyco electronics 36501J022JTDG
MSL1 ^[1]	micro stripline	1.14 mm × 0.8 mm × 10.95 mm	input match	
MSL2 ^[1]	micro stripline	1.14 mm × 0.8 mm × 10.8 mm	input match	
MSL3 ^[1]	micro stripline	1.14 mm × 0.8 mm × 7.3 mm	output match	
MSL4 ^[1]	micro stripline	1.14 mm × 0.8 mm × 4.3 mm	output match	

Table 19. 3.3 V/130 mA application list of components; 2405 MHz to 2485 MHz ...continued

See [Figure 35](#) and [Figure 40](#) for component layout. Printed-Circuit Board (PCB): Rogers RO4003C stack; height = 0.508 mm; copper plating thickness = 35 μm.

Component	Description	Value	Function	Remarks
MSL5 ^[1]	micro stripline	1.14 mm × 0.8 mm × 10.95 mm	output match	
R1	resistor	2.2 Ω		Multicomp MC 0.063W 0603 2R2
R2	resistor (trimmer)	2 kΩ	bias adjustment	Bourns 3214W-1-202E

[1] MSL1 to MSL5 dimensions specified as Width (W), Spacing (S) and Length (L).

12.3 PCB stack

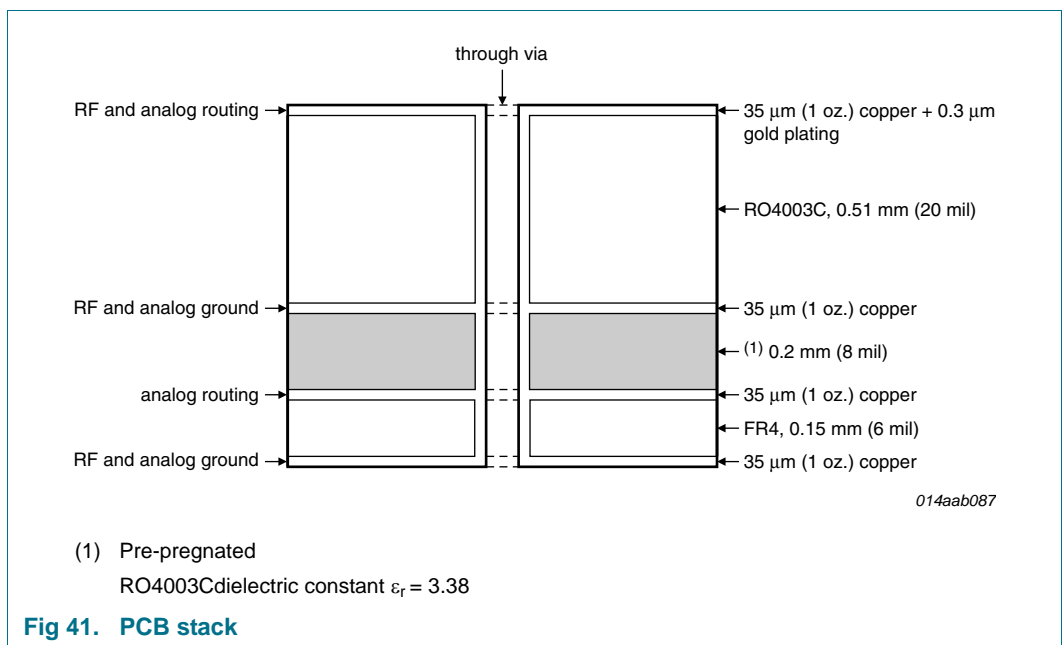

13. Package outline

HVSON8: plastic thermal enhanced very thin small outline package; no leads; 8 terminals; body 3 x 3 x 0.85 mm

SOT908-1

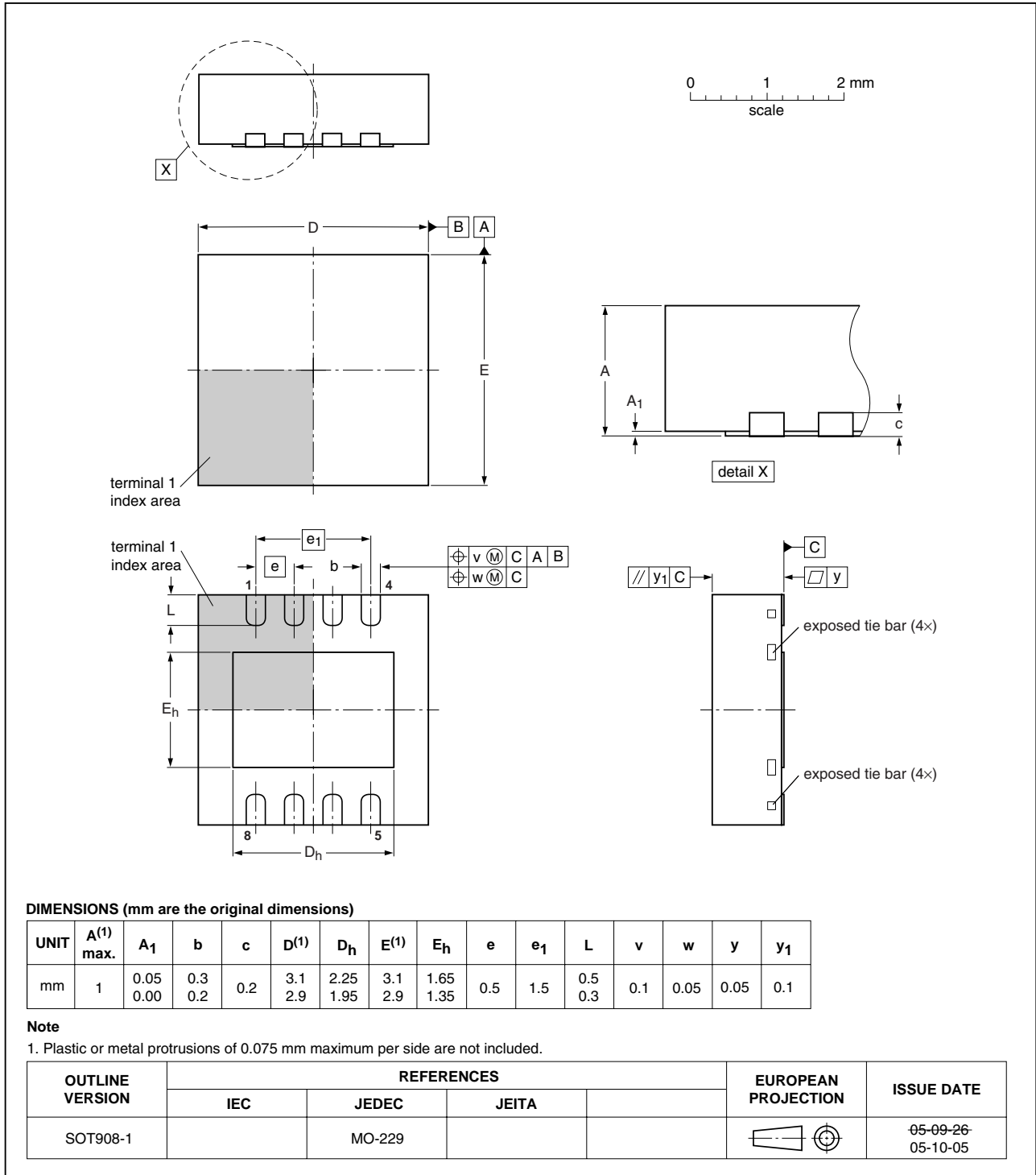

Fig 42. Package outline SOT908-1 (HVSON8)

14. Abbreviations

Table 20. Abbreviations

Acronym	Description
CPE	Customer-Premises Equipment
DC	Direct Current
ESD	ElectroStatic Discharge
HTOL	High Temperature Operating Life
ISM	Industrial, Scientific and Medical
MMIC	Monolithic Microwave Integrated Circuit
MoCA	Multimedia over Coax Alliance
RFID	Radio Frequency IDentification
SMA	SubMiniature version A
TX	Transmit
WLAN	Wireless Local Area Network

15. Revision history

Table 21. Revision history

Document ID	Release date	Data sheet status	Change notice	Supersedes
BGA7124 v.3	20100909	Product data sheet	-	BGA7124 v.2
Modifications:	<ul style="list-style-type: none"> • Figure 5 on page 11: MSL symbols have been corrected. • Figure 11 on page 14: MSL symbols have been corrected. • Figure 17 on page 16: MSL symbols have been corrected. • Figure 23 on page 19: MSL symbols have been corrected. • Figure 29 on page 22: MSL symbols have been corrected. • Figure 35 on page 25: MSL symbols have been corrected. 			
BGA7124 v.2	20100623	Product data sheet	-	BGA7124 v.1
BGA7124 v.1	20100421	Product data sheet	-	-

16. Legal information

16.1 Data sheet status

Document status ^{[1][2]}	Product status ^[3]	Definition
Objective [short] data sheet	Development	This document contains data from the objective specification for product development.
Preliminary [short] data sheet	Qualification	This document contains data from the preliminary specification.
Product [short] data sheet	Production	This document contains the product specification.

[1] Please consult the most recently issued document before initiating or completing a design.

[2] The term 'short data sheet' is explained in section "Definitions".

[3] The product status of device(s) described in this document may have changed since this document was published and may differ in case of multiple devices. The latest product status information is available on the Internet at URL <http://www.nxp.com>.

16.2 Definitions

Draft — The document is a draft version only. The content is still under internal review and subject to formal approval, which may result in modifications or additions. NXP Semiconductors does not give any representations or warranties as to the accuracy or completeness of information included herein and shall have no liability for the consequences of use of such information.

Short data sheet — A short data sheet is an extract from a full data sheet with the same product type number(s) and title. A short data sheet is intended for quick reference only and should not be relied upon to contain detailed and full information. For detailed and full information see the relevant full data sheet, which is available on request via the local NXP Semiconductors sales office. In case of any inconsistency or conflict with the short data sheet, the full data sheet shall prevail.

Product specification — The information and data provided in a Product data sheet shall define the specification of the product as agreed between NXP Semiconductors and its customer, unless NXP Semiconductors and customer have explicitly agreed otherwise in writing. In no event however, shall an agreement be valid in which the NXP Semiconductors product is deemed to offer functions and qualities beyond those described in the Product data sheet.

16.3 Disclaimers

Limited warranty and liability — Information in this document is believed to be accurate and reliable. However, NXP Semiconductors does not give any representations or warranties, expressed or implied, as to the accuracy or completeness of such information and shall have no liability for the consequences of use of such information.

In no event shall NXP Semiconductors be liable for any indirect, incidental, punitive, special or consequential damages (including - without limitation - lost profits, lost savings, business interruption, costs related to the removal or replacement of any products or rework charges) whether or not such damages are based on tort (including negligence), warranty, breach of contract or any other legal theory.

Notwithstanding any damages that customer might incur for any reason whatsoever, NXP Semiconductors' aggregate and cumulative liability towards customer for the products described herein shall be limited in accordance with the *Terms and conditions of commercial sale* of NXP Semiconductors.

Right to make changes — NXP Semiconductors reserves the right to make changes to information published in this document, including without limitation specifications and product descriptions, at any time and without notice. This document supersedes and replaces all information supplied prior to the publication hereof.

Suitability for use — NXP Semiconductors products are not designed, authorized or warranted to be suitable for use in life support, life-critical or safety-critical systems or equipment, nor in applications where failure or

malfunction of an NXP Semiconductors product can reasonably be expected to result in personal injury, death or severe property or environmental damage. NXP Semiconductors accepts no liability for inclusion and/or use of NXP Semiconductors products in such equipment or applications and therefore such inclusion and/or use is at the customer's own risk.

Applications — Applications that are described herein for any of these products are for illustrative purposes only. NXP Semiconductors makes no representation or warranty that such applications will be suitable for the specified use without further testing or modification.

Customers are responsible for the design and operation of their applications and products using NXP Semiconductors products, and NXP Semiconductors accepts no liability for any assistance with applications or customer product design. It is customer's sole responsibility to determine whether the NXP Semiconductors product is suitable and fit for the customer's applications and products planned, as well as for the planned application and use of customer's third party customer(s). Customers should provide appropriate design and operating safeguards to minimize the risks associated with their applications and products.

NXP Semiconductors does not accept any liability related to any default, damage, costs or problem which is based on any weakness or default in the customer's applications or products, or the application or use by customer's third party customer(s). Customer is responsible for doing all necessary testing for the customer's applications and products using NXP Semiconductors products in order to avoid a default of the applications and the products or of the application or use by customer's third party customer(s). NXP does not accept any liability in this respect.

Limiting values — Stress above one or more limiting values (as defined in the Absolute Maximum Ratings System of IEC 60134) will cause permanent damage to the device. Limiting values are stress ratings only and (proper) operation of the device at these or any other conditions above those given in the Recommended operating conditions section (if present) or the Characteristics sections of this document is not warranted. Constant or repeated exposure to limiting values will permanently and irreversibly affect the quality and reliability of the device.

Terms and conditions of commercial sale — NXP Semiconductors products are sold subject to the general terms and conditions of commercial sale, as published at <http://www.nxp.com/profile/terms>, unless otherwise agreed in a valid written individual agreement. In case an individual agreement is concluded only the terms and conditions of the respective agreement shall apply. NXP Semiconductors hereby expressly objects to applying the customer's general terms and conditions with regard to the purchase of NXP Semiconductors products by customer.

No offer to sell or license — Nothing in this document may be interpreted or construed as an offer to sell products that is open for acceptance or the grant, conveyance or implication of any license under any copyrights, patents or other industrial or intellectual property rights.

Export control — This document as well as the item(s) described herein may be subject to export control regulations. Export might require a prior authorization from national authorities.

Non-automotive qualified products — Unless this data sheet expressly states that this specific NXP Semiconductors product is automotive qualified, the product is not suitable for automotive use. It is neither qualified nor tested in accordance with automotive testing or application requirements. NXP Semiconductors accepts no liability for inclusion and/or use of non-automotive qualified products in automotive equipment or applications.

In the event that customer uses the product for design-in and use in automotive applications to automotive specifications and standards, customer (a) shall use the product without NXP Semiconductors' warranty of the product for such automotive applications, use and specifications, and (b) whenever customer uses the product for automotive applications beyond NXP Semiconductors' specifications such use shall be solely at customer's own risk, and (c) customer fully indemnifies NXP Semiconductors for any

liability, damages or failed product claims resulting from customer design and use of the product for automotive applications beyond NXP Semiconductors' standard warranty and NXP Semiconductors' product specifications.

Export control — This document as well as the item(s) described herein may be subject to export control regulations. Export might require a prior authorization from national authorities.

16.4 Trademarks

Notice: All referenced brands, product names, service names and trademarks are the property of their respective owners.

17. Contact information

For more information, please visit: <http://www.nxp.com>

For sales office addresses, please send an email to: salesaddresses@nxp.com

18. Contents

1	Product profile	1
1.1	General description	1
1.2	Features and benefits	1
1.3	Applications	1
1.4	Quick reference data	1
2	Pinning information	2
2.1	Pinning	2
2.2	Pin description	2
3	Ordering information	2
4	Functional diagram	3
5	Shutdown control	3
6	Limiting values	4
7	Thermal characteristics	5
8	Static characteristics	5
8.1	Supply current adjustment	5
9	Dynamic characteristics	6
9.1	Scattering parameters	9
10	Reliability information	10
11	Moisture sensitivity	10
12	Application information	11
12.1	5 V applications	11
12.1.1	920 MHz to 960 MHz	11
12.1.2	1930 MHz to 1990 MHz	14
12.1.3	2110 MHz to 2170 MHz	16
12.1.4	2405 MHz to 2485 MHz	19
12.2	3.3 V applications	22
12.2.1	920 MHz to 960 MHz	22
12.2.2	2405 MHz to 2485 MHz	25
12.3	PCB stack	28
13	Package outline	29
14	Abbreviations	30
15	Revision history	30
16	Legal information	31
16.1	Data sheet status	31
16.2	Definitions	31
16.3	Disclaimers	31
16.4	Trademarks	32
17	Contact information	32
18	Contents	33

Please be aware that important notices concerning this document and the product(s) described herein, have been included in section 'Legal information'.

© NXP B.V. 2010.

All rights reserved.

For more information, please visit: <http://www.nxp.com>

For sales office addresses, please send an email to: salesaddresses@nxp.com

Date of release: 9 September 2010

Document identifier: BGA7124