

AMIS-30660

High Speed CAN Transceiver

Description

The AMIS-30660 CAN transceiver is the interface between a controller area network (CAN) protocol controller and the physical bus and may be used in both 12 V and 24 V systems. The transceiver provides differential transmit capability to the bus and differential receive capability to the CAN controller.

Due to the wide common-mode voltage range of the receiver inputs, the AMIS-30660 is able to reach outstanding levels of electromagnetic susceptibility (EMS). Similarly, extremely low electromagnetic emission (EME) is achieved by the excellent matching of the output signals.

Features

- Fully Compatible with the ISO 11898-2 Standard
- Certified “Authentication on CAN Transceiver Conformance (d1.1)”
- High Speed (up to 1 Mbit/s)
- Ideally Suited for 12 V and 24 V Industrial and Automotive Applications
- Low EME Common-Mode Choke is No Longer Required
- Differential Receiver with Wide Common-Mode Range (± 35 V) for High EMS
- No Disturbance of the Bus Lines with an Unpowered Node
- Transmit Data (TxD) Dominant Time-out Function
- Thermal Protection
- Bus Pins Protected Against Transients in an Automotive Environment
- Silent Mode in which the Transmitter is Disabled
- Short Circuit Proof to Supply Voltage and Ground
- Logic Level Inputs Compatible with 3.3 V Devices
- These are Pb-Free Devices*



ON Semiconductor®

<http://onsemi.com>

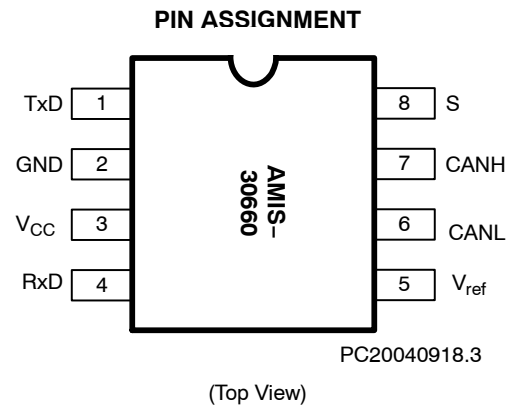
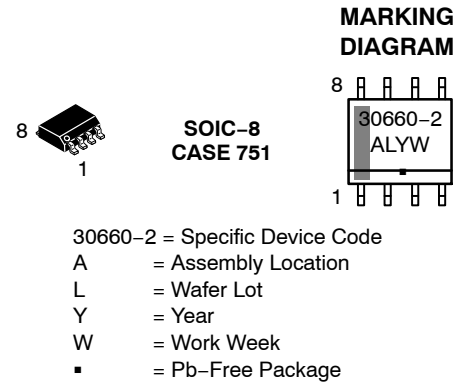

ORDERING INFORMATION

See detailed ordering and shipping information in the package dimensions section on page 9 of this data sheet.

*For additional information on our Pb-Free strategy and soldering details, please download the ON Semiconductor Soldering and Mounting Techniques Reference Manual, SOLDERRM/D.

Table 1. TECHNICAL CHARACTERISTICS

Symbol	Parameter	Conditions	Min	Max	Unit
V_{CANH}	DC Voltage at Pin CANH	$0 < V_{CC} < 5.25 \text{ V}$; No Time Limit	-45	+45	V
V_{CANL}	DC Voltage at Pin CANL	$0 < V_{CC} < 5.25 \text{ V}$; No Time Limit	-45	+45	V
$V_{o(dif)(bus_dom)}$	Differential Bus Output Voltage in Dominant State	$42.5 \Omega < R_{LT} < 60 \Omega$	1.5	3	V
$t_{pd(rec-dom)}$	Propagation Delay TxD to RxD	See Figure 6	70	245	ns
$t_{pd(dom-rec)}$	Propagation Delay TxD to RxD	See Figure 6	100	245	ns
$C_{M-range}$	Input Common-Mode Range for Comparator	Guaranteed Differential Receiver Threshold and Leakage Current	-35	+35	V
$V_{CM-peak}$	Common-Mode Peak	See Figures 7 and 8 (Note 1)	-500	500	mV
$V_{CM-step}$	Common-Mode Step	See Figures 7 and 8 (Note 1)	-150	150	mV

1. The parameters $V_{CM-peak}$ and $V_{CM-step}$ guarantee low electromagnetic emission.

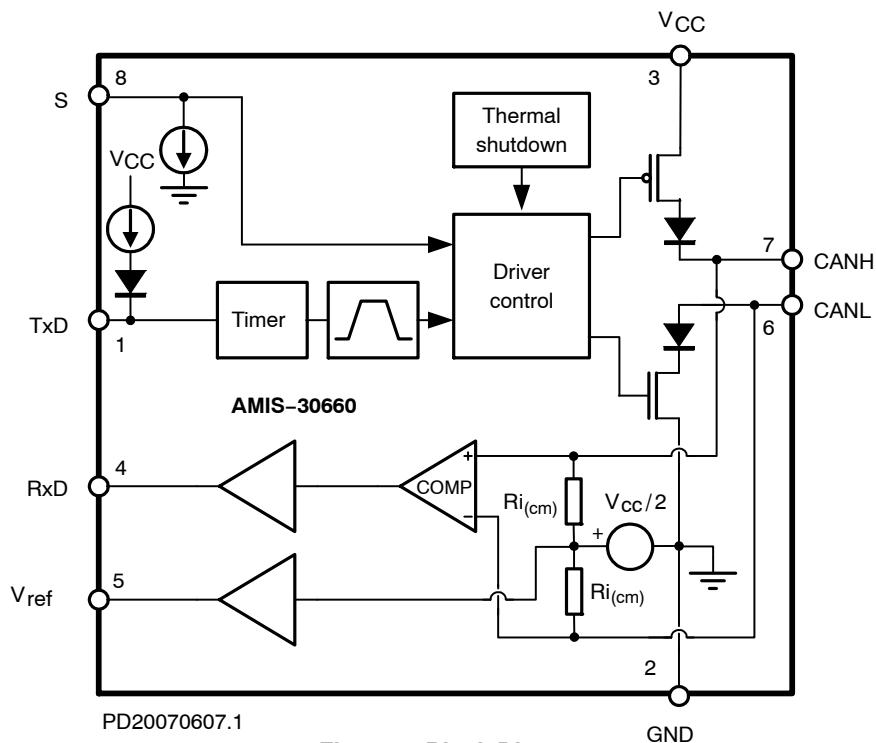

Figure 1. Block Diagram

Table 2. PIN LIST AND DESCRIPTIONS

Pin	Name	Description
1	TxD	Transmit data input; low input → dominant driver; internal pull-up current
2	GND	Ground
3	V _{CC}	Supply voltage
4	RxD	Receive data output; dominant transmitter → low output
5	V _{REF}	Reference voltage output
6	CANL	Low-level CAN bus line (low in dominant mode)
7	CANH	High-level CAN bus line (high in dominant mode)
8	S	Silent mode control input; internal pull-down current

Table 3. ABSOLUTE MAXIMUM RATINGS

Symbol	Parameter	Conditions	Min	Max	Unit
V _{CC}	Supply Voltage		-0.3	+7	V
V _{CANH}	DC Voltage at Pin CANH	0 < V _{CC} < 5.25 V; No Time Limit	-45	+45	V
V _{CANL}	DC Voltage at Pin CANL	0 < V _{CC} < 5.25 V; No Time Limit	-45	+45	V
V _{TxD}	DC Voltage at Pin TxD		-0.3	V _{CC} + 0.3	V
V _{RxD}	DC Voltage at Pin RxD		-0.3	V _{CC} + 0.3	V
V _S	DC Voltage at Pin S		-0.3	V _{CC} + 0.3	V
V _{ref}	DC Voltage at Pin V _{REF}		-0.3	V _{CC} + 0.3	V
V _{tran(CANH)}	Transient Voltage at Pin CANH	(Note 2)	-150	+150	V
V _{tran(CANL)}	Transient Voltage at Pin CANL	(Note 2)	-150	+150	V
V _{esd}	Electrostatic Discharge Voltage at All Pins	(Note 3) (Note 5)	-4 -500	+4 +500	kV V
Latchup	Static Latchup at All Pins	(Note 4)		100	mA
T _{stg}	Storage Temperature		-55	+155	°C
T _{amb}	Ambient Temperature		-40	+125	°C
T _{Junc}	Maximum Junction Temperature		-40	+150	°C

Stresses exceeding Maximum Ratings may damage the device. Maximum Ratings are stress ratings only. Functional operation above the Recommended Operating Conditions is not implied. Extended exposure to stresses above the Recommended Operating Conditions may affect device reliability.

2. Applied transient waveforms in accordance with ISO 7637 part 3, test pulses 1, 2, 3a, and 3b (see Figure 4).
3. Standardized human body model ESD pulses in accordance to MIL883 method 3015.7.
4. Static latch-up immunity: static latch-up protection level when tested according to EIA/JESD78.
5. Standardized charged device model ESD pulses when tested according to EOS/ESD DS5.3-1993.

Table 4. THERMAL CHARACTERISTICS

Symbol	Parameter	Conditions	Value	Unit
R _{th(vj-a)}	Thermal Resistance from Junction-to-Ambient in SOIC-8 Package	In Free Air	150	K/W
R _{th(vj-s)}	Thermal resistance from Junction-to-Substrate of Bare Die	In Free Air	45	K/W

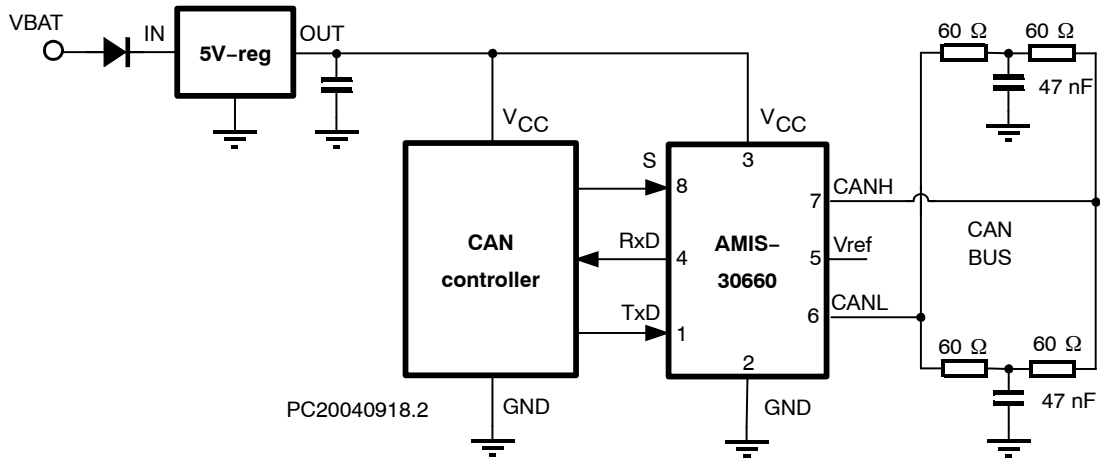

Figure 2. Application Diagram

FUNCTIONAL DESCRIPTION

Operating Modes

The behavior of AMIS-30660 under various conditions is illustrated in Table 5 below. In case the device is powered, one of two operating modes can be selected through Pin S.

Table 5. FUNCTIONAL TABLE OF AMIS-30660 (X = DON'T CARE)

VCC	Pin TxD	Pin S	Pin CANH	Pin CANL	Bus State	Pin RxD
4.75 V to 5.25 V	0	0 (or Floating)	High	Low	Dominant	0
4.75 V to 5.25 V	X	1	$V_{CC} / 2$	$V_{CC} / 2$	Recessive	1
4.75 V to 5.25 V	1 (or Floating)	X	$V_{CC} / 2$	$V_{CC} / 2$	Recessive	1
$V_{CC} < \text{PORL}$ (Unpowered)	X	X	$0 \text{ V} < \text{CANH} < V_{CC}$	$0 \text{ V} < \text{CANL} < V_{CC}$	Recessive	1
$\text{PORL} < V_{CC} < 4.75 \text{ V}$	$> 2 \text{ V}$	X	$0 \text{ V} < \text{CANH} < V_{CC}$	$0 \text{ V} < \text{CANL} < V_{CC}$	Recessive	1

High-Speed Mode

If Pin S is pulled low (or left floating), the transceiver is in its high-speed mode and is able to communicate via the bus lines. The signals are transmitted and received to the CAN controller via the Pins TxD and RxD. The slopes on the bus line outputs are optimized to give extremely low electromagnetic emissions.

Silent Mode

In silent mode, the transmitter is disabled. All other IC functions continue to operate. The silent mode is selected by connecting Pin S to V_{CC} and can be used to prevent network communication from being blocked, due to a CAN controller which is out of control.

Overtemperature Detection

A thermal protection circuit protects the IC from damage by switching off the transmitter if the junction temperature exceeds a value of approximately 160°C. Because the transmitter dissipates most of the power, the power dissipation and temperature of the IC is reduced. All other IC functions continue to operate. The transmitter off-state resets when Pin TxD goes high. The thermal protection

circuit is particularly necessary when a bus line short-circuits.

TxD Dominant Time-out Function

A TxD dominant time-out timer circuit prevents the bus lines from being driven to a permanent dominant state (blocking all network communication) if Pin TxD is forced permanently low by a hardware and/or software application failure. The timer is triggered by a negative edge on pin TxD. If the duration of the low-level on Pin TxD exceeds the internal timer value t_{dom} , the transmitter is disabled, driving the bus into a recessive state. The timer is reset by a positive edge on Pin TxD.

Fail-Safe Features

A current-limiting circuit protects the transmitter output stage from damage caused by an accidental short-circuit to either positive or negative supply voltage, although power dissipation increases during this fault condition.

The Pins CANH and CANL are protected from automotive electrical transients (according to “ISO 7637”; see Figure 3). Pin TxD is pulled high internally should the input become disconnected.

ELECTRICAL CHARACTERISTICS

Definitions

All voltages are referenced to GND (Pin 2). Positive currents flow into the IC. Sinking current means the current

is flowing into the pin; sourcing current means the current is flowing out of the pin.

Table 6. DC AND TIMING CHARACTERISTICS

(V_{CC} = 4.75 V to 5.25 V; T_{junc} = -40°C to +150°C; R_{LT} = 60 Ω unless specified otherwise.)

Symbol	Parameter	Conditions	Min	Typ	Max	Unit
SUPPLY (Pin V_{CC})						
I _{CC}	Supply Current	Dominant; V _{TxD} = 0 V Recessive; V _{TxD} = V _{CC}	25 2	45 4	65 8	mA
I _{CCS}	Supply Current in silent mode	V _S = V _{CC}	2	4	8	mA
TRANSMITTER DATA INPUT (Pin TxD)						
V _{IH}	High-level input voltage	Output recessive	2.0	-	V _{CC} +0.3	V
V _{IL}	Low-level input voltage	Output dominant	-0.3	-	+0.8	V
I _{IH}	High-level input current	V _{TxD} = V _{CC}	-1	0	+1	μA
I _{IL}	Low-level input current	V _{TxD} = 0 V	-75	-200	-350	μA
C _i	Input capacitance	Not tested	-	5	10	pF
MODE SELECT (Pin S)						
V _{IH}	High-level input voltage	Silent mode	2.0	-	V _{CC} +0.3	V
V _{IL}	Low-level input voltage	High-speed mode	-0.3	-	+0.8	V
I _{IH}	High-level input current	V _S = 2 V	20	30	50	μA
I _{IL}	Low-level input current	V _S = 0.8 V	15	30	45	μA
RECEIVER DATA OUTPUT (Pin RxD)						
V _{OH}	High-level output voltage	I _{RxD} = - 10 mA	0.6 x V _{CC}	0.75 x V _{CC}		V
V _{OL}	Low-level output voltage	I _{RxD} = 6 mA		0.25	0.45	V
REFERENCE VOLTAGE OUTPUT (Pin V_{ref})						
V _{REF}	Reference output voltage	-50 μA < I _{VREF} < +50 μA	0.45 x V _{CC}	0.50 x V _{CC}	0.55 x V _{CC}	V
V _{REF_CM}	Reference output voltage for full common mode range	-35 V < V _{CANH} < +35V; -35 V < V _{CANL} < +35V	0.40 x V _{CC}	0.50 x V _{CC}	0.60 x V _{CC}	V
BUS LINES (Pins CANH and CANL)						
V _{o(reces)} (CANH)	Recessive bus voltage at pin CANH	V _{TxD} = V _{CC} ; no load	2.0	2.5	3.0	V
V _{o(reces)} (CANL)	Recessive bus voltage at pin CANL	V _{TxD} = V _{CC} ; no load	2.0	2.5	3.0	V
I _{o(reces)} (CANH)	Recessive output current at pin CANH	-35 V < V _{CANH} < +35 V; 0 V < V _{CC} < 5.25 V	-2.5	-	+2.5	mA
I _{o(reces)} (CANL)	Recessive output current at pin CANL	-35 V < V _{CANL} < +35 V; 0V < V _{CC} < 5.25 V	-2.5	-	+2.5	mA
V _{o(dom)} (CANH)	Dominant output voltage at pin CANH	V _{TxD} = 0 V	3.0	3.6	4.25	V
V _{o(dom)} (CANL)	Dominant output voltage at pin CANL	V _{TxD} = 0 V	0.5	1.4	1.75	V
V _{o(dif)} (bus)	Differential bus output voltage (V _{CANH} - V _{CANL})	V _{TxD} = 0 V; dominant; 42.5 Ω < R _{LT} < 60 Ω	1.5	2.25	3.0	V
		V _{TxD} = V _{CC} ; recessive; No load	-120	0	+50	mV
I _{o(sc)} (CANH)	Short circuit output current at pin CANH	V _{CANH} = 0 V; V _{TxD} = 0 V	-45	-70	-95	mA
I _{o(sc)} (CANL)	Short circuit output current at pin CANL	V _{CANL} = 36V; V _{TxD} = 0V	45	70	120	mA

AMIS-30660

Table 6. DC AND TIMING CHARACTERISTICS

($V_{CC} = 4.75\text{ V to }5.25\text{ V}$; $T_{junc} = -40^{\circ}\text{C to }+150^{\circ}\text{C}$; $R_{LT} = 60\ \Omega$ unless specified otherwise.)

Symbol	Parameter	Conditions	Min	Typ	Max	Unit
BUS LINES (Pins CANH and CANL)						
$V_{i(dif)}(th)$	Differential receiver threshold voltage	$-5\text{ V} < V_{CANL} < +10\text{ V}$; $-5\text{ V} < V_{CANH} < +10\text{ V}$; See Figure 4	0.5	0.7	0.9	V
$V_{ihcm(dif)}(th)$	Differential receiver threshold voltage for high common-mode	$-35\text{ V} < V_{CANL} < +35\text{ V}$; $-35\text{ V} < V_{CANH} < +35\text{ V}$; See Figure 4	0.25	0.7	1.05	V
$V_{i(dif)}(hys)$	Differential receiver input voltage hysteresis	$-5\text{ V} < V_{CANL} < +10\text{ V}$; $-5\text{ V} < V_{CANH} < +10\text{ V}$; See Figure 4	50	70	100	mV
$R_{i(cm)}(CANH)$	Common-mode input resistance at pin CANH		15	25	37	K Ω
$R_{i(cm)}(CANL)$	Common-mode input resistance at pin CANL		15	25	37	K Ω
$R_{i(cm)}(m)$	Matching between pin CANH and pin CANL common-mode input resistance	$V_{CANH} = V_{CANL}$	-3	0	+3	%
$R_{i(dif)}$	Differential input resistance		25	50	75	K Ω
$C_{i(CANH)}$	Input capacitance at pin CANH	$V_{TxD} = V_{CC}$; not tested		7.5	20	pF
$C_{i(CANL)}$	Input capacitance at pin CANL	$V_{TxD} = V_{CC}$; not tested		7.5	20	pF
$C_{i(dif)}$	Differential input capacitance	$V_{TxD} = V_{CC}$; not tested		3.75	10	pF
$I_{LI}(CANH)$	Input leakage current at pin CANH	$V_{CC} = 0\text{ V}$; $V_{CANH} = 5\text{ V}$	10	170	250	μA
$I_{LI}(CANL)$	Input leakage current at pin CANL	$V_{CC} = 0\text{ V}$; $V_{CANL} = 5\text{ V}$	10	170	250	μA
$V_{CM-peak}$	Common-mode peak during transition from dom \rightarrow rec or rec \rightarrow dom	See Figures 7 and 8	-500		500	mV
$V_{CM-step}$	Difference in common-mode between dominant and recessive state	See Figures 7 and 8		-150	150	mV
POWER-ON-RESET (POR)						
PORL	POR level	CANH, CANL, V_{ref} in tri-state below POR level	2.2	3.5	4.5	V
THERMAL SHUTDOWN						
$T_{j(sd)}$	Shutdown junction temperature		150	160	180	$^{\circ}\text{C}$
TIMING CHARACTERISTICS (see Figures 5 and 6)						
$t_{d(TxD-BUSon)}$	Delay TxD to bus active	$V_s = 0\text{ V}$	40	85	130	ns
$t_{d(TxD-BUSoff)}$	Delay TxD to bus inactive	$V_s = 0\text{ V}$	30	60	105	ns
$t_{d(BUSon-RxD)}$	Delay bus active to RxD	$V_s = 0\text{ V}$	25	55	105	ns
$t_{d(BUSoff-RxD)}$	Delay bus inactive to RxD	$V_s = 0\text{ V}$	65	100	135	ns
$t_{pd(rec-dom)}$	Propagation delay TxD to RxD from recessive to dominant	$V_s = 0\text{ V}$	70		245	ns
$t_{d(dom-rec)}$	Propagation delay TxD to RxD from dominant to recessive	$V_s = 0\text{ V}$	100		245	ns
$t_{dom(TxD)}$	TxD dominant time for time out	$V_{TxD} = 0\text{ V}$	250	450	750	μs

AMIS-30660

MEASUREMENT SEUPS AND DEFINITIONS

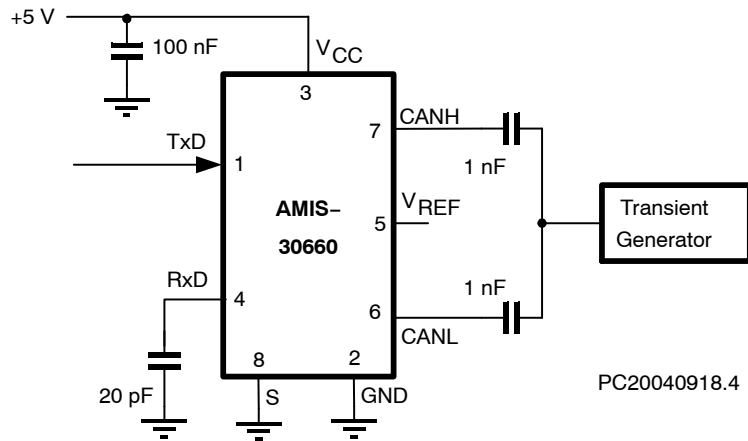

Figure 3. Test Circuit for Automotive Transients

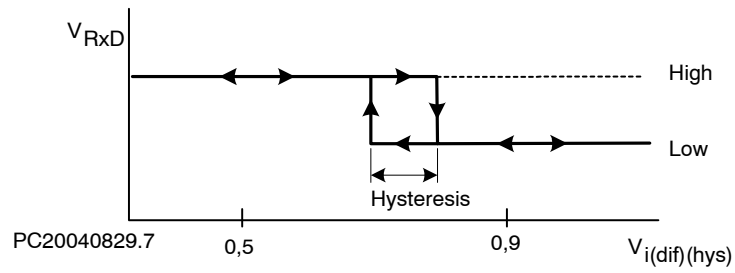

Figure 4. Hysteresis of the Receiver

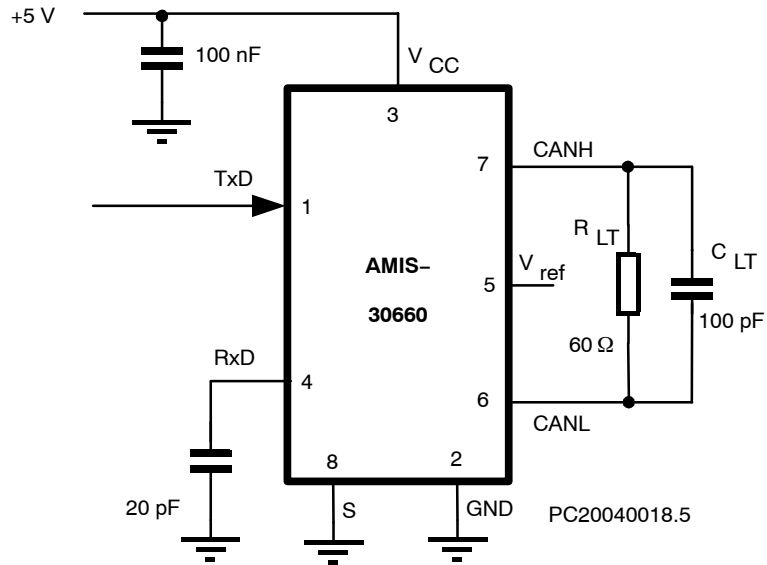

Figure 5. Test Circuit for Timing Characteristics

AMIS-30660

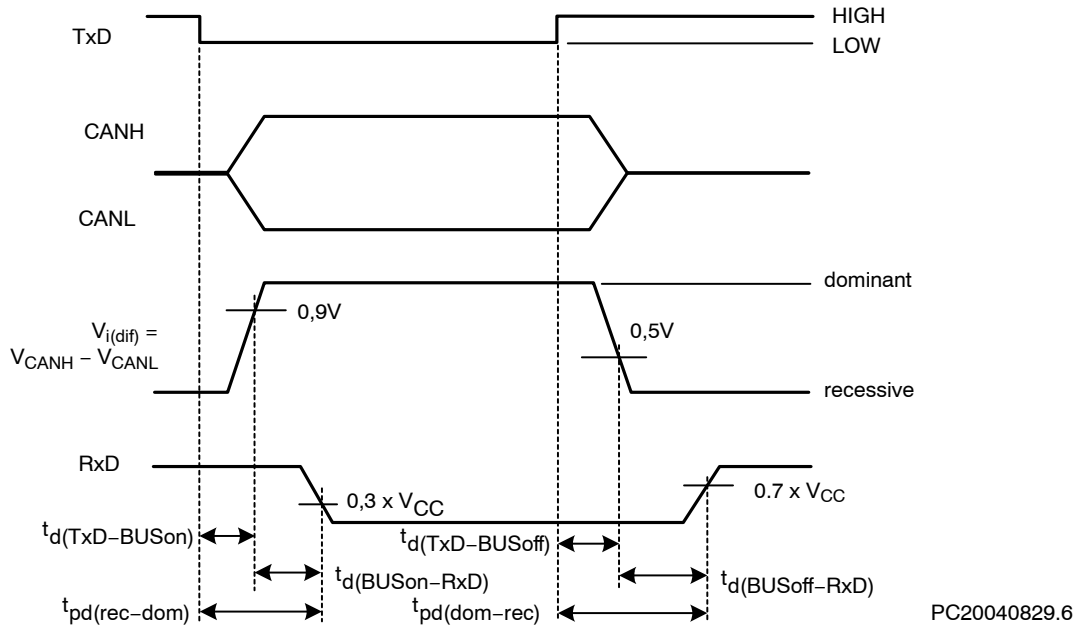

Figure 6. Timing Diagram for AC Characteristics

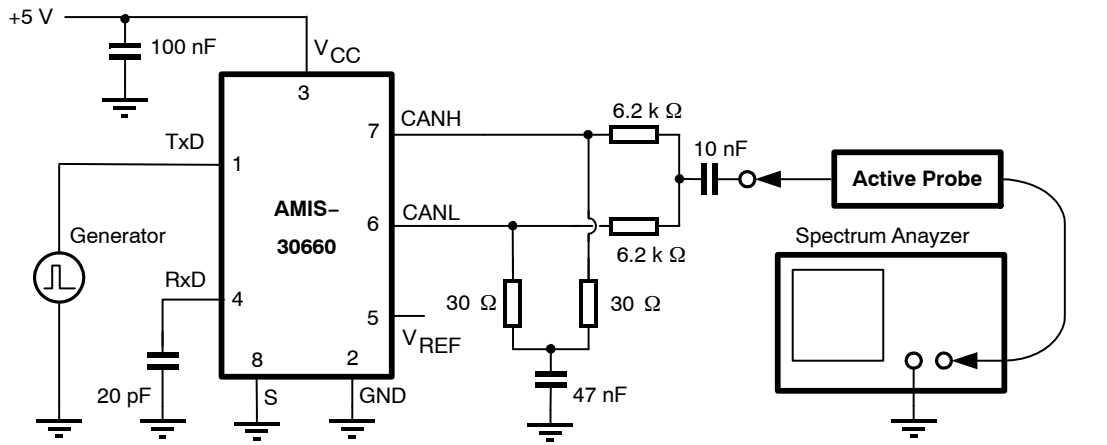

Figure 7. Basic Test Set-up for Electromagnetic Measurement

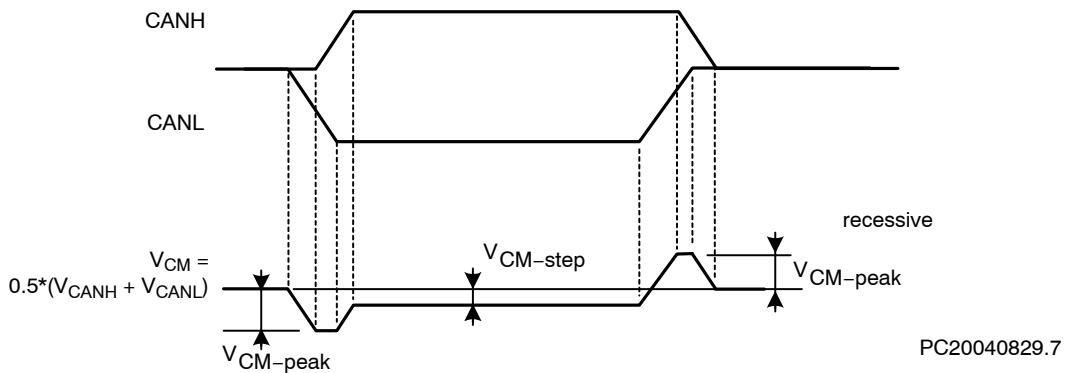

Figure 8. Common-Mode Voltage Peaks (see Measurement Setup)

AMIS-30660

DEVICE ORDERING INFORMATION

Part Number	Description	Temperature Range	Package Type	Shipping†
AMIS30660CANH2G	HS CAN Transc. (5 V) (Matte Sn)	-40°C – 125°C	SOIC-8 (Pb-Free)	96 Tube / Tray
AMIS30660CANH2RG	HS CAN Transc. (5 V) (Matte Sn)	-40°C – 125°C	SOIC-8 (Pb-Free)	3000 / Tape & Reel
AMIS30660CANH6G	HS CAN Transc. (5 V) (NiPdAu)	-40°C – 125°C	SOIC-8 (Pb-Free)	96 Tube / Tray
AMIS30660CANH6RG	HS CAN Transc. (5 V) (NiPdAu)	-40°C – 125°C	SOIC-8 (Pb-Free)	3000 / Tape & Reel

†For information on tape and reel specifications, including part orientation and tape sizes, please refer to our Tape and Reel Packaging Specifications Brochure, BRD8011/D.

AMIS-30660

PACKAGE DIMENSIONS

SOIC-8
CASE 751-07
ISSUE AK

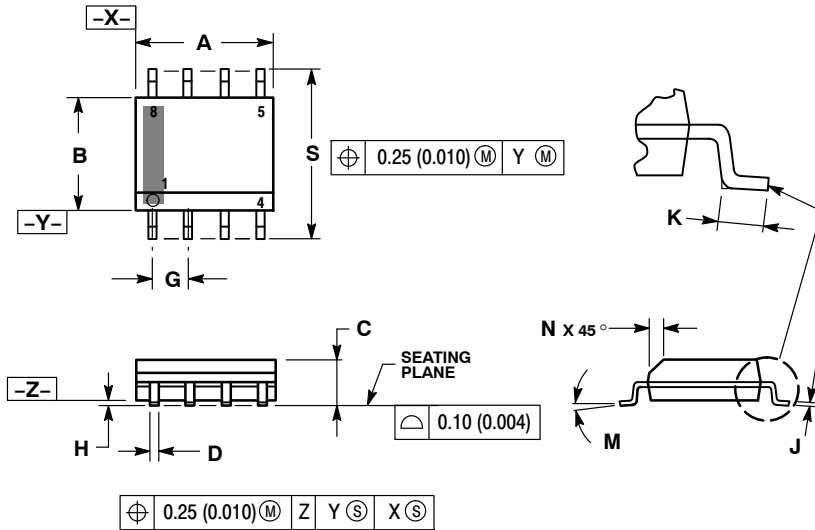

NOTES:

1. DIMENSIONING AND TOLERANCING PER ANSI Y14.5M, 1982.
2. CONTROLLING DIMENSION: MILLIMETER.
3. DIMENSION A AND B DO NOT INCLUDE MOLD PROTRUSION.
4. MAXIMUM MOLD PROTRUSION 0.15 (0.006) PER SIDE.
5. DIMENSION D DOES NOT INCLUDE DAMBAR PROTRUSION. ALLOWABLE DAMBAR PROTRUSION SHALL BE 0.127 (0.005) TOTAL IN EXCESS OF THE D DIMENSION AT MAXIMUM MATERIAL CONDITION.
6. 751-01 THRU 751-06 ARE OBSOLETE. NEW STANDARD IS 751-07.

DIM	MILLIMETERS		INCHES	
	MIN	MAX	MIN	MAX
A	4.80	5.00	0.189	0.197
B	3.80	4.00	0.150	0.157
C	1.35	1.75	0.053	0.069
D	0.33	0.51	0.013	0.020
G	1.27 BSC		0.050 BSC	
H	0.10	0.25	0.004	0.010
J	0.19	0.25	0.007	0.010
K	0.40	1.27	0.016	0.050
M	0°	8°	0°	8°
N	0.25	0.50	0.010	0.020
S	5.80	6.20	0.228	0.244

SOLDERING FOOTPRINT*

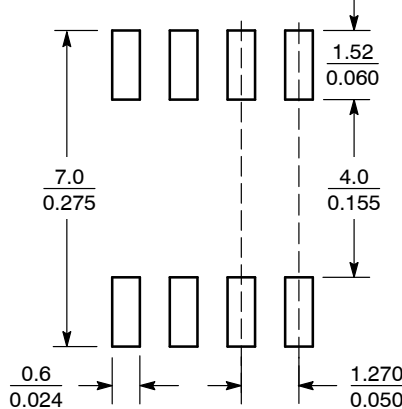

SCALE 6:1 (mm/inches)

*For additional information on our Pb-Free strategy and soldering details, please download the ON Semiconductor Soldering and Mounting Techniques Reference Manual, SOLDERRM/D.

ON Semiconductor and are registered trademarks of Semiconductor Components Industries, LLC (SCILLC). SCILLC owns the rights to a number of patents, trademarks, copyrights, trade secrets, and other intellectual property. A listing of SCILLC's product/patent coverage may be accessed at www.onsemi.com/site/pdf/Patent-Marking.pdf. SCILLC reserves the right to make changes without further notice to any products herein. SCILLC makes no warranty, representation or guarantee regarding the suitability of its products for any particular purpose, nor does SCILLC assume any liability arising out of the application or use of any product or circuit, and specifically disclaims any and all liability, including without limitation special, consequential or incidental damages. "Typical" parameters which may be provided in SCILLC data sheets and/or specifications can and do vary in different applications and actual performance may vary over time. All operating parameters, including "Typicals" must be validated for each customer application by customer's technical experts. SCILLC does not convey any license under its patent rights nor the rights of others. SCILLC products are not designed, intended, or authorized for use as components in systems intended for surgical implant into the body, or other applications intended to support or sustain life, or for any other application in which the failure of the SCILLC product could create a situation where personal injury or death may occur. Should Buyer purchase or use SCILLC products for any such unintended or unauthorized application, Buyer shall indemnify and hold SCILLC and its officers, employees, subsidiaries, affiliates, and distributors harmless against all claims, costs, damages, and expenses, and reasonable attorney fees arising out of, directly or indirectly, any claim of personal injury or death associated with such unintended or unauthorized use, even if such claim alleges that SCILLC was negligent regarding the design or manufacture of the part. SCILLC is an Equal Opportunity/Affirmative Action Employer. This literature is subject to all applicable copyright laws and is not for resale in any manner.

PUBLICATION ORDERING INFORMATION

LITERATURE FULFILLMENT:
Literature Distribution Center for ON Semiconductor
P.O. Box 5163, Denver, Colorado 80217 USA
Phone: 303-675-2175 or 800-344-3860 Toll Free USA/Canada
Fax: 303-675-2176 or 800-344-3867 Toll Free USA/Canada
Email: orderlit@onsemi.com

N. American Technical Support: 800-282-9855 Toll Free
USA/Canada
Europe, Middle East and Africa Technical Support:
Phone: 421 33 790 2910
Japan Customer Focus Center
Phone: 81-3-5817-1050

ON Semiconductor Website: www.onsemi.com
Order Literature: <http://www.onsemi.com/orderlit>

For additional information, please contact your local Sales Representative