

NIS6201

Floating, Regulated Charge Pump

The NIS6201 charge pump is designed to provide economical, low level power to circuits above ground level potential, such as the drive for ORing diodes. It is a very cost-effective replacement for a small, isolated, switching power supply.

It contains an internal linear regulator, and a versatile charge pump to allow bias voltage supplies to be transferred from a ground referenced source to a higher potential. The design of the charge pump allows for any isolation voltage required, as the high voltage components are external to the pump and can be sized accordingly.

Features

- Integrated Linear Regulator and Charge Pump
- Thermal Limit Protection
- Adjustable Voltage Output
- High Voltage Isolation
- This is a Pb-Free Device

Applications

- ORing Diodes
- Floating Supervisory Circuits
- LED Driver

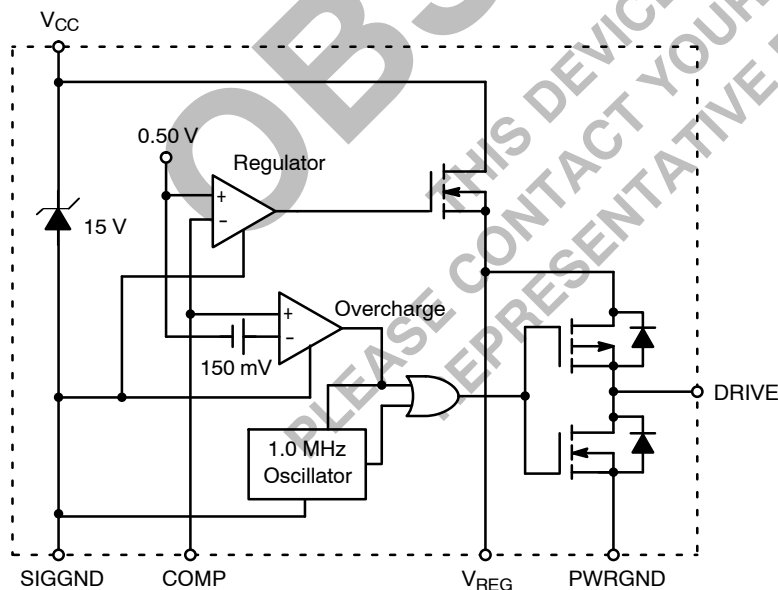

Figure 1. Charge Pump Block Diagram



ON Semiconductor®

<http://onsemi.com>

MARKING DIAGRAM



6201 = Specific Device Code
 A = Assembly Location
 Y = Year
 WW = Work Week
 ■ = Pb-Free Package

PIN CONNECTIONS

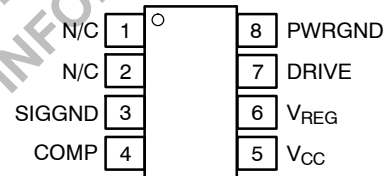

(Top View)

ORDERING INFORMATION

Device	Package	Shipping†
NIS6201DR2G	SOIC-8 (Pb-Free)	3000 / Tape & Reel

†For information on tape and reel specifications, including part orientation and tape sizes, please refer to our Tape and Reel Packaging Specifications Brochure, BRD8011/D.

NIS6201

PIN FUNCTION DESCRIPTION

Pin	Symbol	Description
1, 2	N/C	No connection.
3	SIGGND	Ground reference pin for control circuits. This should be connected to power ground on the PCB.
4	COMP	The feedback and compensation network of the linear regulator are connected to this pin.
5	V _{CC}	Input power to chip. There is an internal clamp at 15 V to allow for a shunt regulator circuit on this pin for high voltage inputs.
6	V _{REG}	This is the regulated output of the internal linear regulator.
7	DRIVE	Output drive of oscillator, that drives external diode/capacitor network.
8	PWRGND	Ground reference pin for driver current.

MAXIMUM RATINGS

Rating	Symbol	Value	Unit
Input Voltage, Operating (Note 1)	V _{CC}	-0.3 to 15	V
Comp pin Voltage	V _{comp}	4.5	V
Drive Current, Peak	I _{Dpk}	3.0	A
Drive Current, Average	I _{Davg}	0.05	A
Thermal Resistance, Junction-to-Air Min copper area 1 in ² copper (1 oz, single sided)	Q _{JA}	175 114	°C/W
Thermal Resistance, Junction-to-Lead (Pin 1)	Q _{JL}	41	°C/W
Power Dissipation @ T _A = 25°C Min copper area 1 in ² copper (1 oz, single sided)	P _{max}	.57 .88	W
Operating Temperature Range	T _J	-40 to 125	°C
Non-operating Temperature Range	T _J	-55 to 150	°C
Lead Temperature, Soldering (10 Sec)	T _L	260	°C

Stresses exceeding Maximum Ratings may damage the device. Maximum Ratings are stress ratings only. Functional operation above the Recommended Operating Conditions is not implied. Extended exposure to stresses above the Recommended Operating Conditions may affect device reliability.

- Above this voltage, a series resistor is necessary to limit current into the shunt regulator.

ELECTRICAL CHARACTERISTICS (Unless otherwise noted: V_{CC} = 15 V, V_{reg} = 12 V, DRIVE Pin open, T_J = 25°C.)

Characteristic	Symbol	Min	Typ	Max	Unit
----------------	--------	-----	-----	-----	------

OSCILLATOR

Frequency	f _{osc}	0.9	1.3	1.45	MHz
-----------	------------------	-----	-----	------	-----

DRIVER

On Resistance, High Side FET	R _{DSon(hi)}	-	9.5	-	Ω
On Resistance, Low Side FET	R _{DSon(low)}	-	9.5	12	Ω

LINEAR REGULATOR

Reference Voltage, Pin 4 T _J = -40 to 125°C	V _{ref}	490 475	500 505	510 525	mV
Headroom (V _{CC} -V _{reg}) V _{CC} = 7 V, I _{drive} = 10 mA	V _{head}	-	155	220	mV

TOTAL DEVICE

Minimum Operational Input Voltage	V _{min}	7.0	-	-	V
Bias Current (Operational)	I _{Bias}	-	3.6	4.6	mA
Bias Current (COMP Pin = 600 mV)	I _{Bias_SD}	-	3.0	3.6	mA
V _{CC} Zener Breakdown Voltage	V _{Zener}	14.5	15	-	V

NIS6201

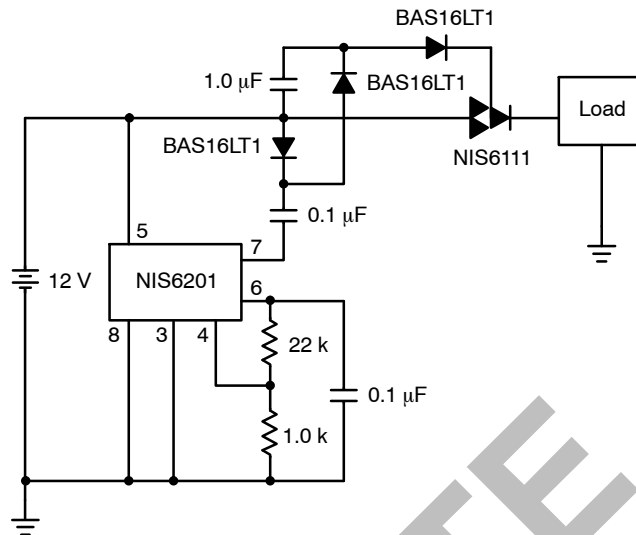

Figure 2. Application Circuit with Better ORing Diode

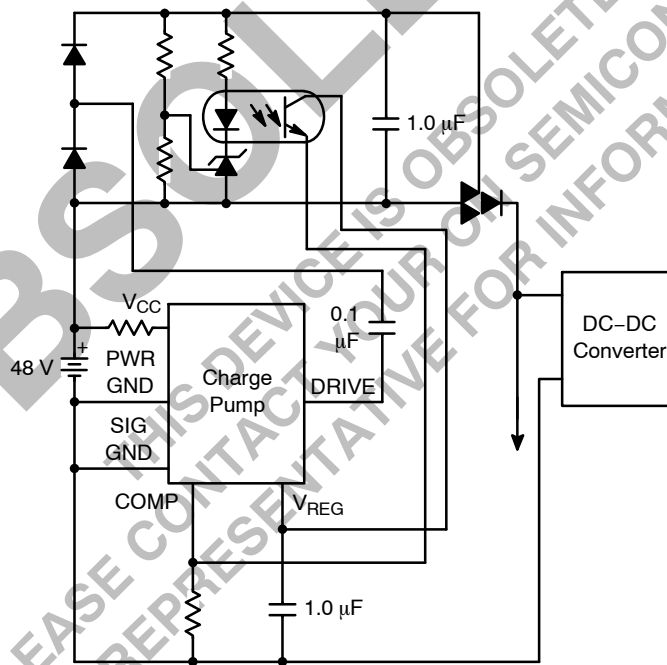

Figure 3. Application Circuit for Improved Regulation and Transient Response

OPERATING DESCRIPTION

DC Input

The Vcc pin is rated for a maximum dc voltage of 15 volts. An internal shunt diode is included for applications where the voltage may exceed 15 volts. For voltages greater than 15 volts an external shunt resistor must be added in series with the Vcc pin. This resistor must be sized such that at low line, the voltage drop across it will allow for an input voltage of greater than that of the output of the LDO and at high line such that the current into the chip does not exceed its power rating.

LDO

The internal LDO contains a P-Channel FET and error amplifier with a 0.5 volt reference. A voltage divider is required from the Vreg pin to the comp pin to set the output of the LDO. This output voltage (Vreg) is the voltage used for the charge pump oscillator. The divider can be calculated from the following formulas:

$$R_{bias} = 0.50 \frac{V}{I_{bias}}$$

Ibias is generally in the range of 100 µA to 1 mA and sets the bias current in the divider.

$$R_{set} = \frac{R_{bias}(V_{reg} - 0.50 V)}{0.50 V}$$

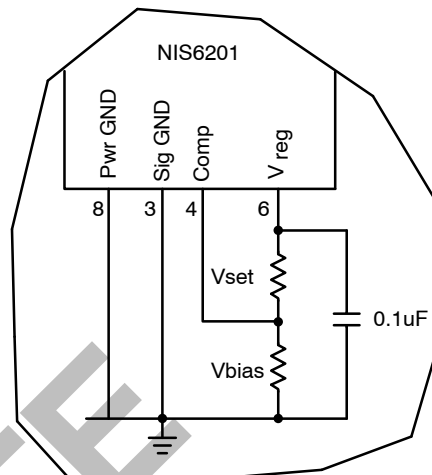

Figure 6. Bias Voltage Divider

Overcharge Comparator

The overcharge comparator provides a protection function from an overvoltage condition at turn-on.

Figure 7 shows a typical configuration for this charge pump. At turn-on there is a voltage divider consisting of two capacitors and two diodes. If this device is being operated at voltages significantly above the Vreg level, it is possible to charge the Vreg cap well beyond its intended level.

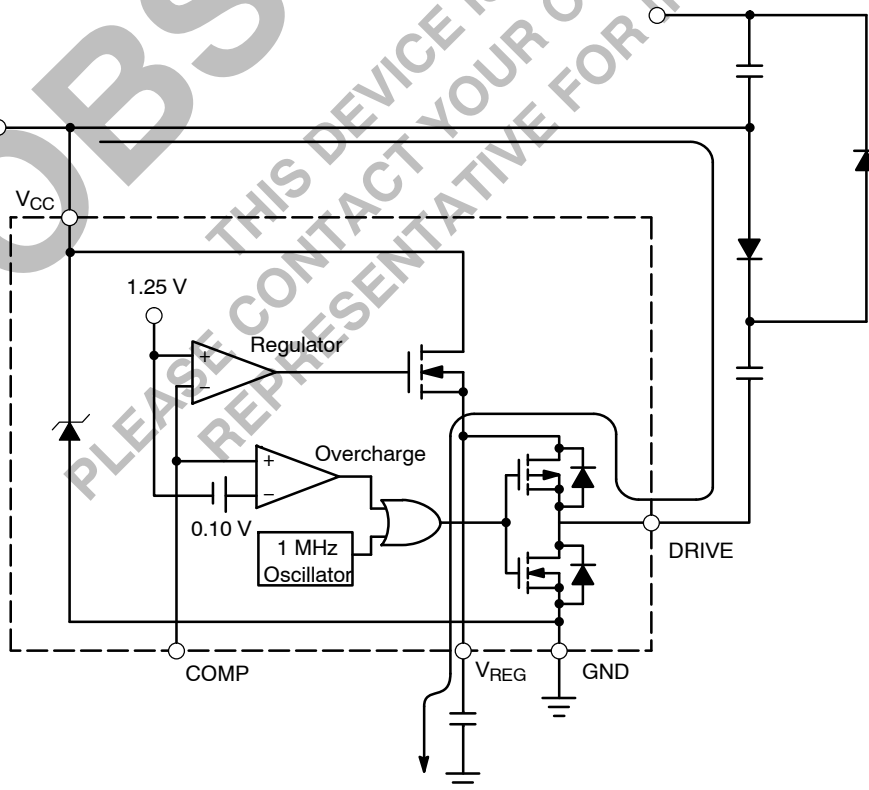

Figure 7. Overcharge Circuit

The overcharge comparator detects when the voltage at Vreg is 10% greater than its set level. If this situation occurs, the overcharge circuit overrides the oscillator and turns on the bottom FET of the driver stage. This shunts the start-up current directly to ground and bypasses the capacitor on Vreg thus allowing for safe start-ups at high input voltages.

Oscillator

The oscillator in this chip operates at a nominal frequency of 1 MHz. The FETs have an on resistance of 20 Ω and can drive loads in excess of 20 mA. Since the charge diodes and capacitors are external, this device can drive a “floating” voltage that is referenced to the input bus such as is shown in Figure 7. The “isolation” voltage for the regulated output is limited only by the ratings of these external components. The oscillator can also drive a conventional voltage doubler circuit or an inverting output stage.

Total Power Consumption

The SO-8 package used for this chip has a power rating of 570 milliwatts. The major losses in this device come from three circuits plus the bias current. These are the following:

Shunt Diode

The power dissipated in this diode is due to the current through the input series resistor when the input exceeds 15 volts. The current in the diode is the current through the input resistor less the output and bias currents in the chip. The output current is equal to the load current unless multiple pump stages are used in which case it is multiplied by the number of stages in use. An additional 2 mA of bias current is required to operate the charge pump.

Pshunt diode =

$$V_{CC} \cdot \left[\left(\frac{V_{in} - V_{CC}}{R_{series}} \right) - 2 \text{ mA} - (I_{out} \cdot n_{stages}) \right]$$

LDO

The power lost in the LDO pass transistor is calculated by the voltage drop across it and the current through it. As was the case with the shunt diode, when calculating the load current, the number of pump stages must be accounted for.

$$P_{LDO} = (V_{CC} - V_{reg}) \cdot (2\text{mA} + (I_{out} \cdot n_{stages}))$$

Oscillator

The power dissipated in the oscillator section can be approximated by multiplying the square of the load current by the typical on resistance.

$$P_{Osc} = I_{out}^2 \cdot 20 \Omega$$

Bias Current

The bias current is simply the input voltage at the Vcc pin multiplied by 2 mA.

The total power dissipated by the chip is the sum of these four losses. If the input voltage does not exceed 15 volts, the shunt diode losses can be ignored. The sum of these losses should not exceed the power rating for the device. Note that the power rating is specified at 25°C and must be derated at higher operating temperatures.

PROLE
 THIS DEVICE IS OBSOLETE
 PLEASE CONTACT YOUR ONSEMI REPRESENTATIVE FOR INFORMATION

NIS6201

PACKAGE DIMENSIONS

SOIC-8 NB CASE 751-07 ISSUE AJ

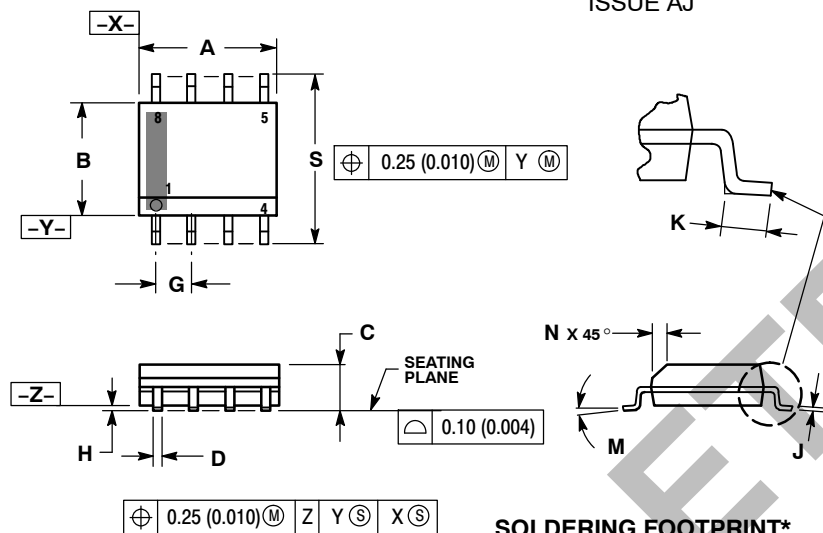

NOTES:

1. DIMENSIONING AND TOLERANCING PER ANSI Y14.5M, 1982.
2. CONTROLLING DIMENSION: MILLIMETER.
3. DIMENSION A AND B DO NOT INCLUDE MOLD PROTRUSION.
4. MAXIMUM MOLD PROTRUSION 0.15 (0.006) PER SIDE.
5. DIMENSION D DOES NOT INCLUDE DAMBAR PROTRUSION. ALLOWABLE DAMBAR PROTRUSION SHALL BE 0.127 (0.005) TOTAL IN EXCESS OF THE D DIMENSION AT MAXIMUM MATERIAL CONDITION.
6. 751-01 THRU 751-06 ARE OBSOLETE. NEW STANDARD IS 751-07.

DIM	MILLIMETERS		INCHES	
	MIN	MAX	MIN	MAX
A	4.80	5.00	0.189	0.197
B	3.80	4.00	0.150	0.157
C	1.35	1.75	0.053	0.069
D	0.33	0.51	0.013	0.020
G	1.27 BSC		0.050 BSC	
H	0.10	0.25	0.004	0.010
J	0.19	0.25	0.007	0.010
K	0.40	1.27	0.016	0.050
M	0°	8°	0°	8°
N	0.25	0.50	0.010	0.020
S	5.80	6.20	0.228	0.244

SOLDERING FOOTPRINT*

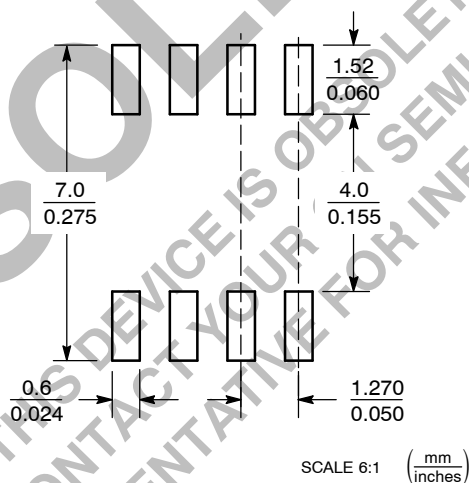

*For additional information on our Pb-Free strategy and soldering details, please download the ON Semiconductor Soldering and Mounting Techniques Reference Manual, SOLDERRM/D.

ON Semiconductor and are registered trademarks of Semiconductor Components Industries, LLC (SCILLC). SCILLC reserves the right to make changes without further notice to any products herein. SCILLC makes no warranty, representation or guarantee regarding the suitability of its products for any particular purpose, nor does SCILLC assume any liability arising out of the application or use of any product or circuit, and specifically disclaims any and all liability, including without limitation special, consequential or incidental damages. "Typical" parameters which may be provided in SCILLC data sheets and/or specifications can and do vary in different applications and actual performance may vary over time. All operating parameters, including "Typicals" must be validated for each customer application by customer's technical experts. SCILLC does not convey any license under its patent rights nor the rights of others. SCILLC products are not designed, intended, or authorized for use as components in systems intended for surgical implant into the body, or other applications intended to support or sustain life, or for any other application in which the failure of the SCILLC product could create a situation where personal injury or death may occur. Should Buyer purchase or use SCILLC products for any such unintended or unauthorized application, Buyer shall indemnify and hold SCILLC and its officers, employees, subsidiaries, affiliates, and distributors harmless against all claims, costs, damages, and expenses, and reasonable attorney fees arising out of, directly or indirectly, any claim of personal injury or death associated with such unintended or unauthorized use, even if such claim alleges that SCILLC was negligent regarding the design or manufacture of the part. SCILLC is an Equal Opportunity/Affirmative Action Employer. This literature is subject to all applicable copyright laws and is not for resale in any manner.

PUBLICATION ORDERING INFORMATION

LITERATURE FULFILLMENT:
Literature Distribution Center for ON Semiconductor
P.O. Box 5163, Denver, Colorado 80217 USA
Phone: 303-675-2175 or 800-344-3860 Toll Free USA/Canada
Fax: 303-675-2176 or 800-344-3867 Toll Free USA/Canada
Email: orderlit@onsemi.com

N. American Technical Support: 800-282-9855 Toll Free USA/Canada
Europe, Middle East and Africa Technical Support:
Phone: 421 33 790 2910
Japan Customer Focus Center
Phone: 81-3-5773-3850

ON Semiconductor Website: www.onsemi.com
Order Literature: <http://www.onsemi.com/orderlit>

For additional information, please contact your local Sales Representative