

# Atmel LED Drivers

## MSL2164/MSL2166

16-String High Efficiency LED Drivers for  
LCD TVs with Advanced Dimming Modes

Datasheet Brief



# Atmel LED Drivers MSL2164 / MSL2166

## 16-String High-Efficiency LED Drivers for LCD TVs with Advanced Dimming Modes

### Features:

- 12-Bit PWM String Dimming
- Forward, Center, Reverse and Inverse PWM Modes
- Fast 20MHz SPI Supports Up to 8 Devices per Bus
- 8-Bit Adaptive Power Correction Maximizes Efficiency for Up to 3 String Power Supplies
- External Current Regulation MOSFETs for High Voltage and/or Current
- Drives Up to 16 Parallel LED Strings Per Device, Cascade Additional Devices for More Strings
- Supports Adaptive, Real-Time Area Dimming for Highest Dynamic Range in LCD TVs and Monitors
- Easily Implements Scrolling, 3D, and Local Dimming Algorithms
- Programmable String Phase Reduces Motion Blur and Improves Efficiency
- Global Intensity Control via SPI Serial Interface
- 0.8% String to String Matching
- PWM Dimming Synchronized to VSYNC and HSYNC Including Frequency Multipliers and Dividers
- Second Set of PWM Registers Select Alternate Brightness and Timing
- Configurable Power-up Defaults Through Internal EEPROM
- LED Open Circuit and Short Circuit Fault Detection
- Individual Fault Detection Enabled for Each String
- Over-Temperature Shutdown Protection
- Broadcast Write Simplifies Configuration
- -40°C To +85°C Operating Temperature Range

The MSL2164/MSL2166 compact, high-power LED string drivers use external current control MOSFETs to sink up to 350mA per string, with matching better than  $\pm 0.8\%$ . The MSL2164/MSL2166 drive 16 parallel strings of LEDs and offer fault detection and management of open-circuit and short-circuit LEDs.

The MSL2164/MSL2166 feature a 20MHz SPI serial interface. Both devices support video frame-by-frame LED string intensity control for up to eight interconnected devices, allowing active area dimming and phase-shifted PWM outputs. They also include an advanced PWM engine that synchronizes PWM dimming to the video signal supporting forward, center, reverse and inverse PWM modes for reduced motion blur and waterfall noise.

The MSL2164/MSL2166 adaptively control any topology DC-DC or AC/DC converter that power the LED strings. The patent-pending "Efficiency Optimizers" minimize power use while maintaining LED current accuracy.

A unique combination of LED current control and pulse width dimming management offers simple full-screen brightness control, versatile area dimming and a consistent white point. Full-scale LED regulation current is set for each string using current sense resistors and a 10-bit register that controls global string current. The 12-bit global intensity register controls PWM dimming of all strings, and each string uses a 12-bit register to control individual string PWM dimming.

The MSL2164/MSL2166 monitor the LED strings for open-circuit, short-circuit, loss-of-sync and over-temperature faults, and provide a hardware fault output (FLTb) to notify the microcontroller. Detailed fault status and control are available through the serial interface. Additionally, the MSL2164/MSL2166 include on-chip EEPROMs that allow customizing of the register power-up states via the serial interface.

The MSL2164/MSL2166 are offered in a 9 x 9 x 0.85mm, 64-pin TQFN package and operate over the -40°C to 85°C temperature range.

### Applications:

#### Long-Life, Efficient LED Backlighting for:

- Televisions and Desktop Monitors
- Medical and Industrial Instrumentation
- Automotive Audio-visual Displays

#### Channel Signs

#### Architectural Lighting

### Ordering Information:

16-CHANNEL LED STRING DRIVERS		
PART	INTERFACE	PACKAGE
MSL2164	3 FBO	64 pin, 9 x 9 x 0.85mm TQFN
MSL2166	2 FBO + 1 FBI	64 pin, 9 x 9 x 0.85mm TQFN





## Detailed Description

The MSL2164 and MSL2166 are highly integrated, flexible, 16-string LED drivers that use external MOSFETs to allow high LED string currents and/or voltage. They include power supply control to maximize efficiency and an advanced PWM dimming control circuit for regional dimming and 3D LED backlights. The drivers optionally connect to a video subsystem to offer a simple architecture for use in LCD TV backlight applications. Up to eight devices easily connect together to drive large numbers of LED strings in a system. The drivers provide multiple methods of controlling LED brightness, through both LED regulation current control and through PWM dimming. Set the LED current to control color and use pulse width control for brightness management and motion blur reduction. An on-chip EEPROM stores all the default control register values, which are applied at start-up and reconfigured through the serial data interface.

The MSL2164/MSL2166 interface to a microcontroller or FPGA via SPI. The 20MHz bus addressable SPI interface supports up to eight devices per Chip Select line. LED PWM dimming is internally generated and synchronized to the video VSYNC and HSYNC signals or directly controlled by an external PWM drive signal applied to the PWM input. They also feature phase spreading when external PWM dimming, with a progressive 1/16 phase delay per string to reduce LED power supply transient load and reduce power supply input capacitor size.

PWM dimming is either synchronized to an external signal applied to PHI, generated from the internal oscillator for stand-alone applications or set directly by a signal at the PWM input. For video systems, derive the PHI signal from VSYNC. A 1x to 32x frequency multiplier processes PHI for PWM dimming at multiples of the video frame rate. Individually program each string's "on" time with up to 12-bit resolution when using the integrated PWM generator. The final PWM dimming resolution depends upon the ratio of the processed GSC to processed PHI frequencies, because the "on" time is an integer number of GSC clock cycles between 0 and 4095, and is scaled by the value of the 12-bit global intensity register. Phase delay is also an integer number of processed GSC clock cycles, to synchronize timing to the video frame. An on-chip frequency multiplier is provided in order to fully utilize the 12-bit dimming range. The "on" time count can be further scaled by a 12-bit global intensity value.

The processed GSC signal (the signal after being frequency multiplied or divided, from either internally or externally generated signal at GSC) precisely sets each string's phase delay so that it is synchronized to its physical position on the LCD panel, relative to the beginning, middle or end of the video frame. There are four different types of PWM modulation modes, each defined by the part of the "on" time or off-time set by the PHDLYn[11:0] register (part of the STRnSET register). The modes are "forward," "center,"

"reverse," and "inverse". All four modes use the PHDLYn register to set the defined edge, and PWMn[11:0] to set the "on" time as a number of processed GSC pulses. The four different modes and register definitions are illustrated in the figure below, showing the current waveforms. The delay for string 0 is held at 0, and the PWM width is the same for both strings and all the modes. Datan in the figure refers to both the dimming data and the phase delay data presented for the nth frame. For "forward" mode PHDLYn specifies the number of processed GSC cycles after the processed PHI edge that the string "on" time begins and the PWMn register specifies the "on" time. In this mode the falling edge varies with the "on" time width programmed in the PWMn register, with the rising edge held constant. In "center" mode, the delay is set from the processed PHI edge to the center of the PWM on pulse with width set by the PWMn register. Both the rising and falling edge vary based on the PWMn with the center held constant within a processed GSC cycle. In "reverse" mode, the PHDLYn sets the delay from the next frame's processed PHI edge to the falling edge of the PWM "on" time and the PWMn register determines the PWM "on" time. Therefore the rising edge varies with PWMn and the falling edge is held constant. In "inverse" mode, the delay is set from the next frames PHI edge backwards to the falling edge of the "on" time. The rising edge varies with the PWMn register, while the falling edge is held constant.

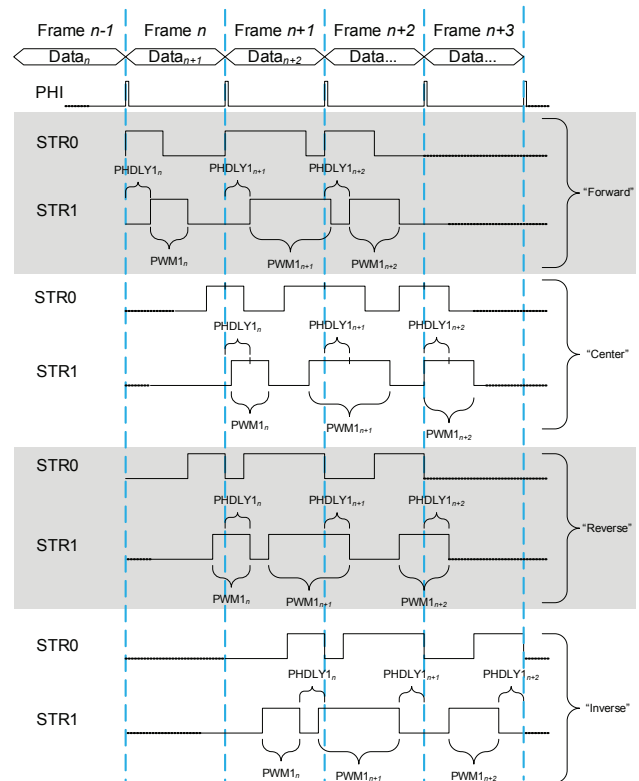

# Atmel LED Drivers MSL2164/MSL2166

16-String High-Efficiency LED Drivers for LCD TVs with Advanced Dimming Modes

## Block Diagram

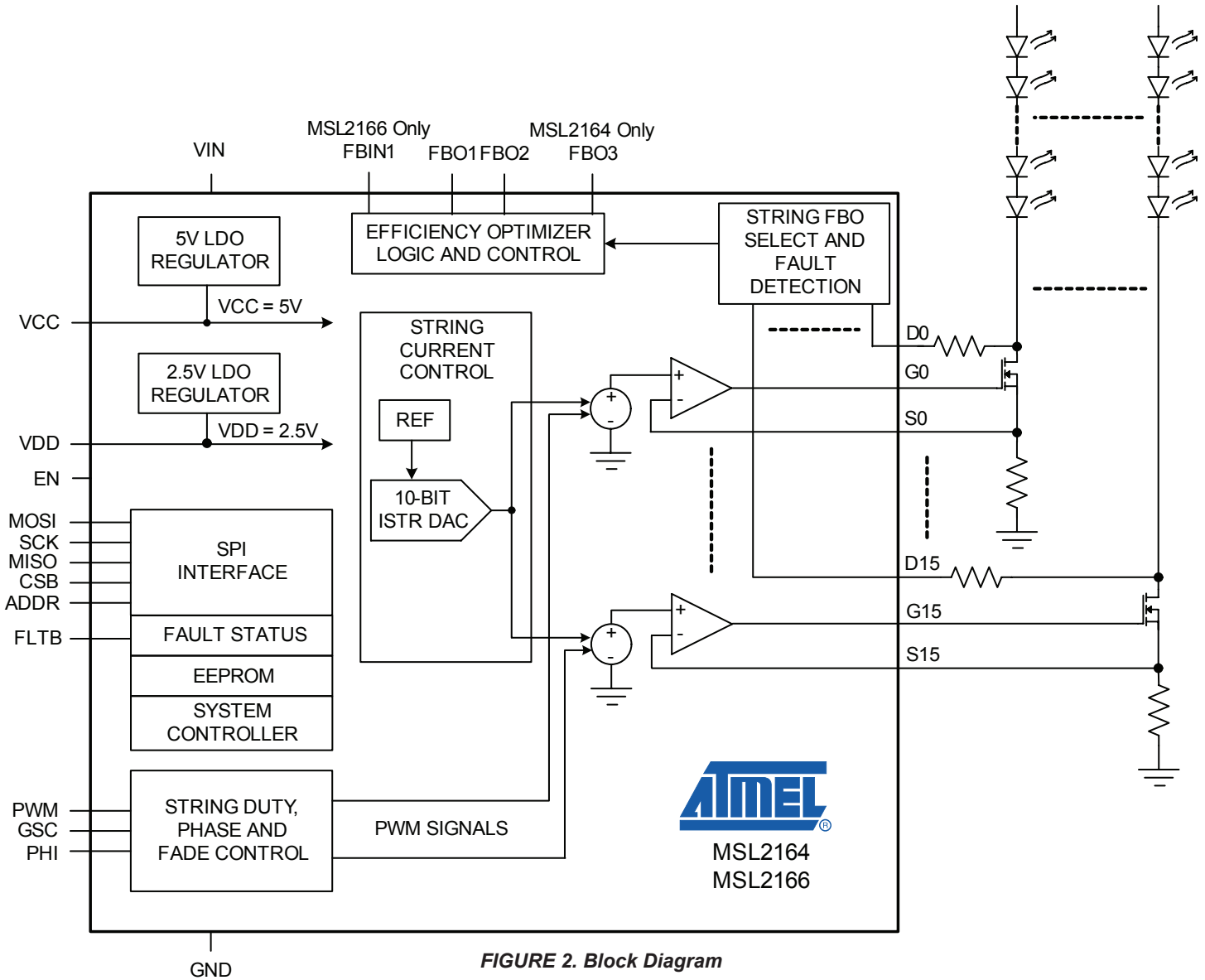



## Package / Pin Out

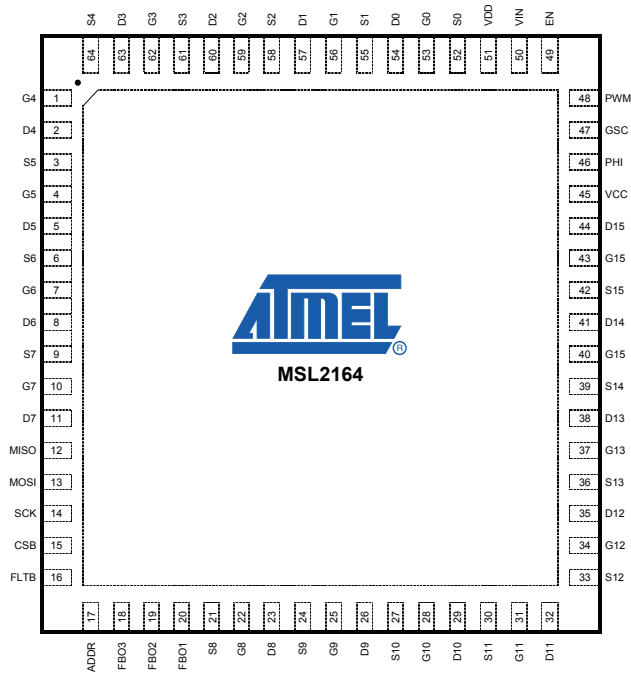

FIGURE 3: Pinning 64-Pin TQFN MSL2164 (9 x 9mm)

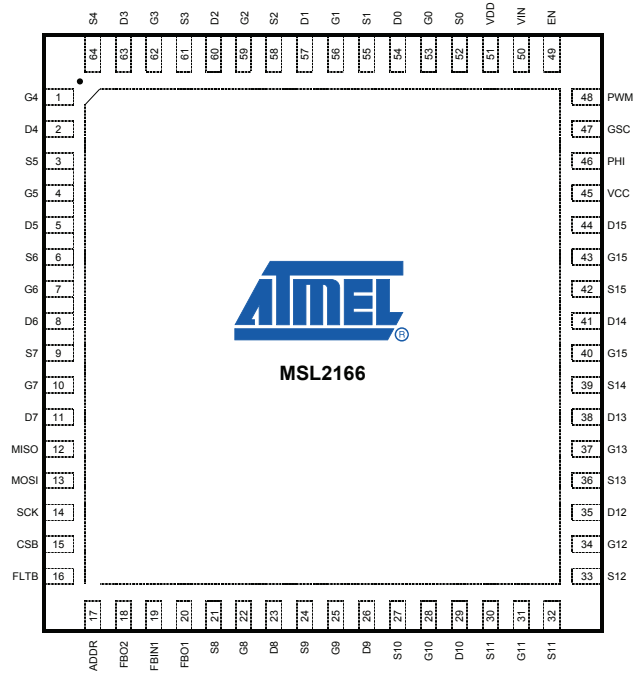
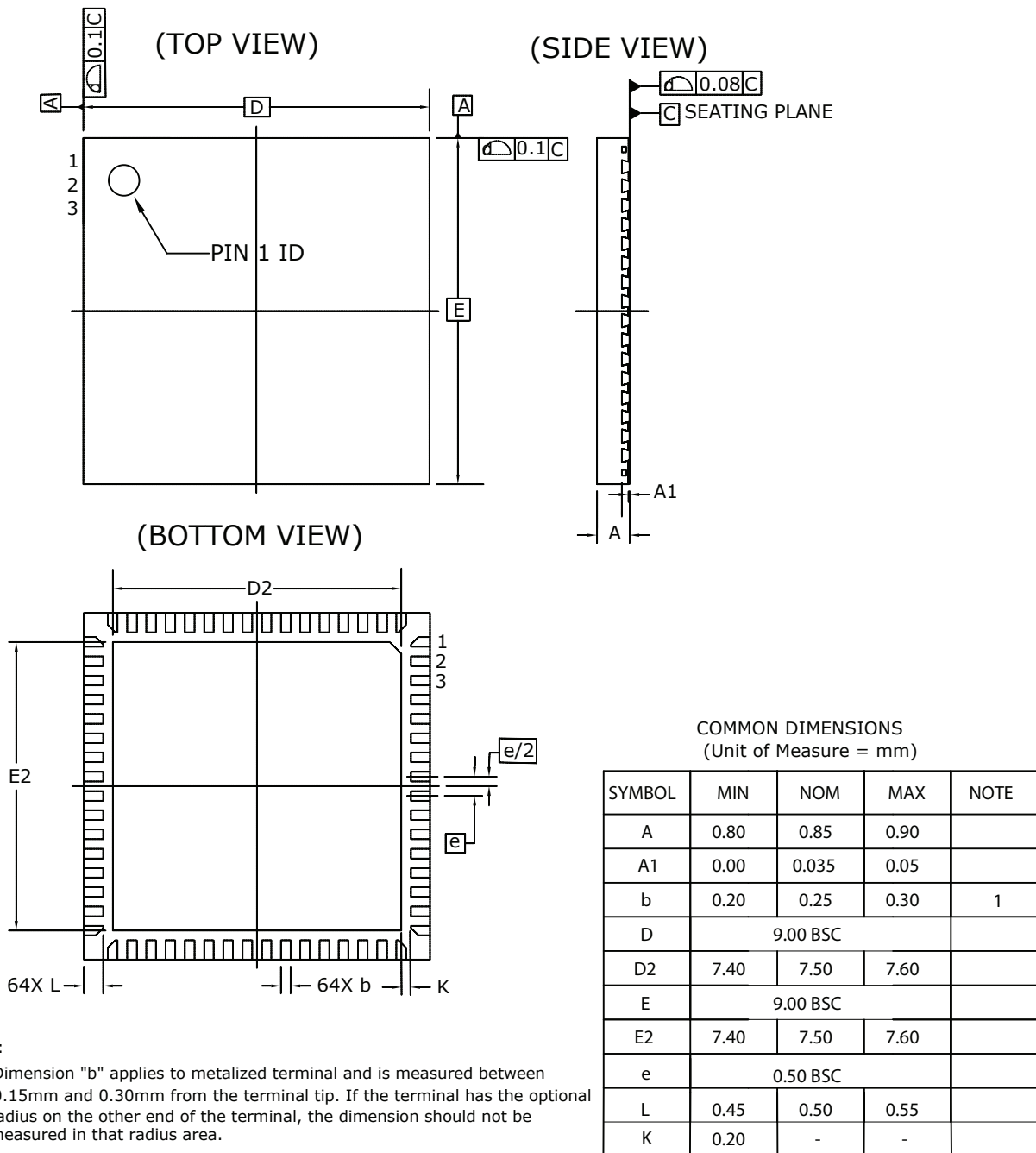

FIGURE 4: Pinning 64-Pin TQFN MSL2166 (9 x 9mm)

# Atmel LED Drivers MSL2164/MSL2166

16-String High-Efficiency LED Drivers for LCD TVs with Advanced Dimming Modes



**FIGURE 5. Package Dimensions: 64-pin, 9mm x 9mm x 0.85mm TQFN (0.5mm pin pitch) with Exposed Pad.**



## Package Connection Description

PIN #	MSL2166	MSL2164	PIN DESCRIPTION
1	G4	G4	Gate Output 4: External MOSFET Gate Drive Output for LED string 4. Connect G4 to the gate of the external MOSFET driving LED string 4. If unused, leave G4 unconnected.
2	D4	D4	Drain Sense Input 4: External MOSFET Drain Sense Input for LED string 4. Connect D4 through a 10MΩ resistor to the drain of the external MOSFET driving LED string 4. If unused, connect D4 to ground.
3	S5	S5	Source Sense Input 5: Source and Current Sense Input for LED string 5. Connect S5 to the source of the external MOSFET and to the current sense resistor for LED string 5. The full scale LED current is reached when 500mV is across the current sense resistor. If unused, connect S5 to ground.
4	G5	G5	Gate Output 5: External MOSFET Gate Drive Output for LED string 5. Connect G5 to the gate of the external MOSFET driving LED string 5. If unused, leave G5 unconnected.
5	D5	D5	Drain Sense Input 5: External MOSFET Drain Sense Input for LED string 5. Connect D5 through a 10MΩ resistor to the drain of the external MOSFET driving LED string 5. If unused, connect D5 to ground.
6	S6	S6	Source Sense Input 6: Source and Current Sense Input for LED string 6. Connect S6 to the source of the external MOSFET and to the current sense resistor for LED string 6. The full scale LED current is reached when 500mV is across the current sense resistor. If unused, connect S6 to ground.
7	G6	G6	Gate Output 6: External MOSFET Gate Drive Output for LED string 6. Connect G6 to the gate of the external MOSFET driving LED string 6. If unused, leave G6 unconnected.
8	D6	D6	Drain Sense Input 6: External MOSFET Drain Sense Input for LED string 6. Connect D6 through a 10MΩ resistor to the drain of the external MOSFET driving LED string 6. If unused, connect D6 to ground.
9	S7	S7	Source Sense Input 7: Source and Current Sense Input for LED string 7. Connect S7 to the source of the external MOSFET and to the current sense resistor for LED string 7. The full scale LED current is reached when 500mV is across the current sense resistor. If unused, connect S7 to ground.
10	G7	G7	Gate Output 7: External MOSFET Gate Drive Output for LED string 7. Connect G7 to the gate of the external MOSFET driving LED string 7. If unused, leave G7 unconnected.
11	D7	D7	Drain Sense Input 7: External MOSFET Drain Sense Input for LED string 7. Connect D7 through a 10MΩ resistor to the drain of the external MOSFET driving LED string 7. If unused, connect D7 to ground.
12	MISO	MISO	Master Input Slave Output: MISO is the MSL2164/MSL2166 (slave) SPI serial data output and the master data input. Connect MISO to the SPI master data input.
13	MOSI	MOSI	Master Output Slave Input: MOSI is the MSL2164/MSL2166 (slave) SPI serial data input and the master data output. Connect MOSI to the SPI master data output.
14	SCK	SCK	SCK is the SPI interface clock input. The SPI master generates the clock. Connect SCK to the master SPI interface clock output.
15	CSB	CSB	Chip Select Bar: CSB is the SPI interface chip select input. Drive CSB low to enable SPI transactions.
16	FLT B	FLT B	Fault Indication Output (Open Drain, Active Low): Open drain output FLT B sinks current to GND whenever a fault is detected. FLT B remains low until the fault registers are read, and reasserts if the fault persists.
17	ADDR	ADDR	Slave ID Selection Inputs: Connect ADDR to GND through a resistor to set the serial interface address.
18	-	FBO3	Efficiency Optimizer Output 3: Connect FBO3 to the third power supply's feedback node.
	FBO2	-	Efficiency Optimizer Output 2 : Connect FBO2 to the second power supply's feedback node.
19	-	FBO2	Efficiency Optimizer Output 2: Connect FBO2 to the second power supply's feedback node.
	FBIN1	-	Efficiency Optimizer Input 1: Connect FBIN1 to FBO1 of the next device when chaining devices (Figure 8-5). If unused connect FBIN1 to ground.
20	FBO1	FBO1	Efficiency Optimizer Output 1 : Connect FBO1 to the first power supply's feedback node.
21	S8	S8	Source Sense Input 8 : Source and Current Sense Input for LED string 8. Connect S8 to the source of the external MOSFET and to the current sense resistor for LED string 8. The full scale LED current is reached when 500mV is across the current sense resistor. If unused, connect S8 to ground.
22	G8	G8	Gate Output 8: External MOSFET Gate Drive Output for LED string 8. Connect G8 to the gate of the external MOSFET driving LED string 8. If unused, leave G8 unconnected.
23	D8	D8	Drain Sense Input 8: External MOSFET Drain Sense Input for LED string 8. Connect D8 through a 10MΩ resistor to the drain of the external MOSFET driving LED string 8. If unused, connect D8 to ground.
24	S9	S9	Source Sense Input 9: Source and Current Sense Input for LED string 9. Connect S9 to the source of the external MOSFET and to the current sense resistor for LED string 9. The full scale LED current is reached when 500mV is across the current sense resistor. If unused, connect S9 to ground.
25	G9	G9	Gate Output 9: External MOSFET Gate Drive Output for LED string 9. Connect G9 to the gate of the external MOSFET driving LED string 9. If unused, leave G9 unconnected.
26	D9	D9	Drain Sense Input 9: External MOSFET Drain Sense Input for LED string 9. Connect D9 through a 10MΩ resistor to the drain of the external MOSFET driving LED string 9. If unused, connect D9 to ground.
27	S10	S10	Source Sense Input 10 : Source and Current Sense Input for LED string 10. Connect S10 to the source of the external MOSFET and to the current sense resistor for LED string 10. The full scale LED current is reached when 500mV is across the current sense resistor. If unused, connect S10 to ground.
28	G10	G10	Gate Output 10: External MOSFET Gate Drive Output for LED string 10. Connect G10 to the gate of the external MOSFET driving LED string 10. If unused, leave G10 unconnected.
29	D10	D10	Drain Sense Input 10: External MOSFET Drain Sense Input for LED string 10. Connect D10 through a 10MΩ resistor to the drain of the external MOSFET driving LED string 10. If unused, connect D10 to ground.
30	S11	S11	Source Sense Input 11 : Source and Current Sense Input for LED string 11. Connect S11 to the source : the external MOSFET and to the current sense resistor for LED string 11. The full scale LED current is reached when 500mV is across the current sense resistor. If unused, connect S119 to ground.
31	G11	G11	Gate Output 11: External MOSFET Gate Drive Output for LED string 11. Connect G11 to the gate of the external MOSFET driving LED string 11. If unused, leave G11 unconnected.
32	D11	D11	Drain Sense Input 11: External MOSFET Drain Sense Input for LED string 11. Connect D11 through a 10MΩ resistor to the drain of the external MOSFET driving LED string 11. If unused, connect D11 to ground.
33	S12	S12	Source Sense Input 12 : Source and Current Sense Input for LED string 12. Connect S12 to the source of the external MOSFET and to the current sense resistor for LED string 12. The full scale LED current is reached when 500mV is across the current sense resistor. If unused, connect S12 to ground.
26	D9	D9	Drain Sense Input 9: External MOSFET Drain Sense Input for LED string 9. Connect D9 through a 10MΩ resistor to the drain of the external MOSFET driving LED string 9. If unused, connect D9 to ground.
27	S10	S10	Source Sense Input 10 : Source and Current Sense Input for LED string 10. Connect S10 to the source of the external MOSFET and to the current sense resistor for LED string 10. The full scale LED current is reached when 500mV is across the current sense resistor. If unused, connect S10 to ground.
28	G10	G10	Gate Output 10: External MOSFET Gate Drive Output for LED string 10. Connect G10 to the gate of the external MOSFET driving LED string 10. If unused, leave G10 unconnected.
29	D10	D10	Drain Sense Input 10: External MOSFET Drain Sense Input for LED string 10. Connect D10 through a 10MΩ resistor to the drain of the external MOSFET driving LED string 10. If unused, connect D10 to ground.
30	S11	S11	Source Sense Input 11 : Source and Current Sense Input for LED string 11. Connect S11 to the source of the external MOSFET and to the current sense resistor for LED string 11. The full scale LED current is reached when 500mV is across the current sense resistor. If unused, connect S119 to ground.

# Atmel LED Drivers MSL2164/MSL2166

## 16-String High-Efficiency LED Drivers for LCD TVs with Advanced Dimming Modes

PIN #	MSL2166	MSL2164	PIN DESCRIPTION
31	G11	G11	Gate Output 11: External MOSFET Gate Drive Output for LED string 11. Connect G11 to the gate of the external MOSFET driving LED string 11. If unused, leave G11 unconnected.
32	D11	D11	Drain Sense Input 11: External MOSFET Drain Sense Input for LED string 11. Connect D11 through a 10MΩ resistor to the drain of the external MOSFET driving LED string 11. If unused, connect D11 to ground.
33	S12	S12	Source Sense Input 12: Source and Current Sense Input for LED string 12. Connect S12 to the source of the external MOSFET and to the current sense resistor for LED string 12. The full scale LED current is reached when 500mV is across the current sense resistor. If unused, connect S12 to ground.
34	G12	G12	Gate Output 12: External MOSFET Gate Drive Output for LED string 12. Connect G12 to the gate of the external MOSFET driving LED string 12. If unused, leave G12 unconnected.
35	D12	D12	Drain Sense Input 12: External MOSFET Drain Sense Input for LED string 12. Connect D12 through a 10MΩ resistor to the drain of the external MOSFET driving LED string 12. If unused, connect D12 to ground.
36	S13	S13	Source Sense Input 13: Source and Current Sense Input for LED string 13. Connect S13 to the source of the external MOSFET and to the current sense resistor for LED string 13. The full scale LED current is reached when 500mV is across the current sense resistor. If unused, connect S13 to ground.
37	G13	G13	Gate Output 13: External MOSFET Gate Drive Output for LED string 13. Connect G13 to the gate of the external MOSFET driving LED string 13. If unused, leave G13 unconnected.
38	D13	D13	Drain Sense Input 13: External MOSFET Drain Sense Input for LED string 13. Connect D13 through a 10MΩ resistor to the drain of the external MOSFET driving LED string 13. If unused, connect D13 to ground.
39	S14	S14	Source Sense Input 14: Source and Current Sense Input for LED string 14. Connect S14 to the source of the external MOSFET and to the current sense resistor for LED string 14. The full scale LED current is reached when 500mV is across the current sense resistor. If unused, connect S14 to ground.
40	G14	G14	Gate Output 14: External MOSFET Gate Drive Output for LED string 14. Connect G14 to the gate of the external MOSFET driving LED string 14. If unused, leave G14 unconnected.
41	D14	D14	Drain Sense Input 14: External MOSFET Drain Sense Input for LED string 14. Connect D14 through a 10MΩ resistor to the drain of the external MOSFET driving LED string 14. If unused, connect D14 to ground.
42	S15	S15	Source Sense Input 15: Source and Current Sense Input for LED string 15. Connect S15 to the source of the external MOSFET and to the current sense resistor for LED string 15. The full scale LED current is reached when 500mV is across the current sense resistor. If unused, connect S15 to ground.
43	G15	G15	Gate Output 15: External MOSFET Gate Drive Output for LED string 15. Connect G15 to the gate of the external MOSFET driving LED string 15. If unused, leave G15 unconnected.
44	D15	D15	Drain Sense Input 15: External MOSFET Drain Sense Input for LED string 15. Connect D15 through a 10MΩ resistor to the drain of the external MOSFET driving LED string 15. If unused, connect D15 to ground.
45	VCC	VCC	5V internal LDO Regulator Output: VCC is the 5V source that powers internal circuits. Bypass VCC to GND with a 4.7μF or greater ceramic capacitor placed close to the MSL2164/MSL2166.
46	PHI	PHI	Phase Synchronization Input: Drive PHI with an external signal from 40Hz to 10kHz to synchronize the MSL2164/MSL2166's internal PWM dimming to the external signal. In video systems drive PHI with VSYNC.
47	GSC	GSC	Gate Shift Clock Input: Drive GSC with the gate shift clock of the video signal, from the PHI frequency up to 1.5MHz. In video systems drive GSC with HSYNC.
48	PWM	PWM	PWM Input: Pulse-Width modulation control input. Drive PWM with a pulse-width modulated signal with duty cycle ranging from 0% to 100% and frequency up to 5kHz.
49	EN	EN	Enable (On/Off) Control Input: Drive EN high to turn on the MSL2164/MSL2166, drive EN low to turn it off. For automatic startup connect EN to V <sub>IN</sub> . Driving EN low-to-high turns on the MSL2164/MSL2166 and initiates a boot load of the EEPROM data into the control registers.
50	V <sub>IN</sub>	V <sub>IN</sub>	Supply Voltage Input: Connect a 12V ±10% supply to VIN. Bypass VIN to GND with a 10μF ceramic capacitor placed close to VIN.
51	VDD	VDD	2.5V internal LDO Regulator Output: VDD is the 2.5V source that powers internal logic. Bypass VDD to GND with a 4.7μF ceramic capacitor placed close to the MSL2164/MSL2166.
52	S0	S0	Source Sense Input 0: Source and Current Sense Input for LED string0. Connect S0 to the source of the external MOSFET and to the current sense resistor for LED string 0. The full scale LED current is reached when 500mV is across the current sense resistor. If unused, connect S0 to ground.
53	G0	G0	Gate Output 0: External MOSFET Gate Drive Output for LED string 0. Connect G0 to the gate of the external MOSFET driving LED string 0. If unused, leave G0 unconnected.
54	D0	D0	Drain Sense Input 0: External MOSFET Drain Sense Input for LED string 0. Connect D0 through a 10MΩ resistor to the drain of the external MOSFET driving LED string 0. If unused, connect D0 to ground.
55	S1	S1	Source Sense Input 1: Source and Current Sense Input for LED string1. Connect S1 to the source of the external MOSFET and to the current sense resistor for LED string 1. The full scale LED current is reached when 500mV is across the current sense resistor. If unused, connect S1 to ground.
56	G1	G1	Gate Output 1: External MOSFET Gate Drive Output for LED string 1. Connect G1 to the gate of the external MOSFET driving LED string 1. If unused, leave G1 unconnected.
57	D1	D1	Drain Sense Input 1: External MOSFET Drain Sense Input for LED string 1. Connect D1 through a 10MΩ resistor to the drain of the external MOSFET driving LED string 1. If unused, connect D1 to ground.
58	S2	S2	Source Sense Input 2: Source and Current Sense Input for LED string 2. Connect S2 to the source of the external MOSFET and to the current sense resistor for LED string 2. The full scale LED current is reached when 500mV is across the current sense resistor. If unused, connect S2 to ground.
59	G2	G2	Gate Output 2: External MOSFET Gate Drive Output for LED string 2. Connect G2 to the gate of the external MOSFET driving LED string 2. If unused, leave G2 unconnected.
60	D2	D2	Drain Sense Input 2: External MOSFET Drain Sense Input for LED string 2. Connect D2 through a 10MΩ resistor to the drain of the external MOSFET driving LED string 2. If unused, connect D2 to ground.
61	S3	S3	Source Sense Input 3: Source and Current Sense Input for LED string 3. Connect S3 to the source of the external MOSFET and to the current sense resistor for LED string 3. The full scale LED current is reached when 500mV is across the current sense resistor. If unused, connect S3 to ground.
62	G3	G3	Gate Output 3: External MOSFET Gate Drive Output for LED string 3. Connect G3 to the gate of the external MOSFET driving LED string 3. If unused, leave G3 unconnected.
63	D3	D3	Drain Sense Input 3: External MOSFET Drain Sense Input for LED string 3. Connect D3 through a 10MΩ resistor to the drain of the external MOSFET driving LED string 3. If unused, connect D3 to ground.
64	S4	S4	Source and Current Sense Input for LED string 4. Connect S4 to the source of the external MOSFET and to the current sense resistor for LED string 4. The full scale LED current is reached when 500mV is across the current sense resistor. If unused, connect S4 to ground.
EP	EP	EP	Exposed Paddle, Power Ground: EP is the exposed die attach paddle which acts as a low thermal resistance path for the die and as power ground. Connect EP to system ground, and to GND using short, wide traces.



## Register Map and the EEPROM

Control the MSL2164/MSL2166 using the registers in the range 0x00 through 0xBF. Two additional registers, 0xC0 and 0xC1, control EEPROM reading and writing. The control register power-on values are stored in EEPROM, and can be changed through the serial interface.

ADDRESS AND REGISTER NAME		FUNCTION	REGISTER DATA								
			D7	D6	D5	D4	D3	D2	D1	D0	
0x00	STRINGENO	LED String Enables	STR7EN	STR6EN	STR5EN	STR4EN	STR3EN	STR2EN	STR1EN	STROEN	
0x01	STRINGEN1		STR15EN	STR14EN	STR13EN	STR12EN	STR11EN	STR10EN	STR9EN	STR8EN	
0x02	CONFIG	Configuration	SLEEP	-	-	-	FLDBKEN	STRSCDLY[2:0]			
0x03	FLTEN	Fault Enable	-	-	-	PHIMAXFEN	GSCMAXFEN	STRSCFEN	STROCFEN	FBOOCFEN	
0x04	STRFLTENO	String Fault Enable	FEN7	FEN6	FEN5	FEN4	FEN3	FEN2	FEN1	FENO	
0x05	STRFLTEN1		FEN15	FEN14	FEN13	FEN12	FEN11	FEN10	FEN9	FEN8	
0x06	FLTSTATUS	Fault Status	FLTBDV	-	-	PHIMAXFLT	GSCMAXFLT	STRSCFLT	STROCFLT	FBOOCFLT	
0x07	OCSTAT0	String Open Circuit Fault Status	OC7	OC6	OC5	OC4	OC3	OC2	OC1	OC0	
0x08	OCSTAT1		OC15	OC14	OC13	OC12	OC11	OC10	OC9	OC8	
0x09	SCSTAT0		SC7	SC6	SC5	SC4	SC3	SC2	SC1	SC0	
0x0A	SCSTAT1	String Short Circuit Fault Status	SC15	SC14	SC13	SC12	SC11	SC10	SC9	SC8	
0x0B thru 0x0E			UNUSED								
0x0F	OSCFREQ	Oscillator Frequency	-	-	-	-	-	-	OSCFREQ[2:0]		
0x10	FBOCTRL0	Efficiency Optimizer Control	HDRMSTEP[1:0]		RECALDLY[1:0]		SETTLE[1:0]		IERRCONF[1:0]		
0x11	FBOCTRL1		INCRSTEP[1:0]		DECRSTEP[1:0]		INITPWM	ACAL100	-	ICHKDIS	
0x12	FBOCTRL2		-	ACALEN3	ACALEN2	ACALEN1	FBO3OCEN	FBO2OCEN	FBO1OCEN	FBOEN	
0x13	FBODAC0		FBODAC1[7:0]								
0x14	FBODAC1		FBODAC2[7:0]								
0x15	FBODAC2	FBODAC3[7:0]									
0x16	FBOSTAT	Efficiency Optimizer Status	FBO3OC	FBO2OC	FBO1OC	FBO3ACT	FBO2ACT	FBO1ACT	FBOCAL	FBOINITCAL	
0x17 thru 0x1F			UNUSED								
0x20	GSCCTRL	GSC Processing Control	GSCCHK-SEL	-	-	-	GSCMAXEN	GSCPOL	GSCPHI-SYNCEN	GSCINTEN	
0x21	GSCNTR	Internal Clock Counter for GSC	GSCNTR[7:0]								
0x22	GSCNTR		GSCNTR[15:8]								
0x23	GSCMUL	GSC Multiplier	-	-	-	-	GSCMUL[4:0]				
0x24	GSCDIV	GSC Divider	GSCDIV[7:0]								
0x25	GSCMAX	Max Oscillator Cycles Between GSC Pulses	GSCMAX[7:0]								
0x26	GSCMAX		GSCMAX[15:8]								
0x27	PHICTRL	PHI Processing Control	PHICHK-SEL	-	-	-	-	PHIMAXEN	PHIPOL	PHIINTEN	
0x28	PHICNTR	Internal Clock Counter for PHI	PHICNTR[7:0]								
0x29	PHICNTR		PHICNTR[15:8]								
0x2A	PHIMUL	PHI Multiplier	-	-	-	-	PHIMUL[4:0]				
0x2B	PHIMAX	Min GSC Pulses Over PHI Period	PHIMAX[7:0]								
0x2C	PHIMAX		PHIMAX[11:8]								
0x2D	PWMCTRL0	PWM Control	GINT+1EN	'1'	ALTEN	OVRFLOZEN	OVRFLOEN	PWMGLBLEN	PWMDIRECT	PWMEN	
0x2E	PWMCTRL1		-	-	-	-	EXTALTEN	PHOVR FLOZEN	PHOVR FLOEN	PHADLYEN	
0x2F			UNUSED								
0x30	GINT	Global PWM Scaling	GINT[7:0]								
0x31	GINT		GINT[11:8]								
0x32	ALTGINT	Alternate Global PWM Scaling	ALTGINT[7:0]								
0x33	ALTGINT		ALTGINT[11:8]								
0x34	ISTR	9-Bit Global String Current	ISTR[7:0]								
0x35	ISTR		ISTR[9:8]								
0x36	PWMSTATUS	PWM & Counter Status	PHIMAXERRCNT[2:0]			PHIMAX1FLT	PHIMULFLT	GSCMULFLT	PHICNTRFLT	GINT-MULERR	
0x37	PHIPCNT	PHI Pulse Counter & Status	PHICNTRMAX	-	-	PHIMULCNTR[0:4]					
0x38	GSCPCNTR	GSC Pulse Counter	GSCPULSECNTR[7:0]								
0x39	GSCPCNTR		GSCPULSECNTR[12:8]								
0x3A	RESERVED	Reserved	'0'	-	-	-	-	-	'0'	'0'	
0x3B	PWMMODE	PWM Mode	PWMMODE[1:0]								
0x3C - 0x3F			UNUSED								
0x40	STROSET	Phase Delay and EO Assignment for String 0	PHDLY0[7:0]				PHDLY0[11:8]				
0x41	STROSET		FBOSET0[1:0]	-	-	-	PHDLY0[11:8]				
..thru..	...thru...	...thru...	...thru...								
0x5E	STR15SET	Phase Delay & EO Assignment for String 15	PHDLY15[7:0]				PHDLY15[11:8]				
0x5F	STR15SET		FBOSET15[1:0]	-	-	-	PHDLY15[11:8]				
0x60	PWM0	11-Bit PWM Setting for String 0	PWM0[7:0]				PWM0[11:8]				
0x61	PWM0		-	-	-	-	PWM0[11:8]				
..thru..	...thru...	...thru...	...thru...								
0x7E	PWM15	11-Bit PWM Setting for String 15	PWM15[7:0]				PWM15[11:8]				
0x7F	PWM15		-	-	-	-	PWM15[11:8]				
0x80	ALTPWM0	Phase Delay and EO Assignment for String 0	ALTPHDLY0[7:0]	-	-	-	-	-	-	-	
0x81	ALTPWM0		-	-	-	-	ALTPHDLY0[11:8]				
..thru..	...thru...	...thru...	...thru...								
0x9E	ALTPWM15	Phase Delay and EO Assignment for String 15	ALTPHDLY15[7:0]				ALTPHDLY15[11:8]				
0x9F	ALTPWM15		-	-	-	-	ALTPHDLY15[11:8]				
0xA0	ALTPWM0	11-Bit PWM Setting for String 0	ALTPWM0[7:0]				ALTPWM0[11:8]				
0xA1	ALTPWM0		-	-	-	-	ALTPWM0[11:8]				
..thru..	...thru...	...thru...	...thru...								
0xBE	ALTPWM15	11-Bit PWM Setting for String 15	ALTPWM15[7:0]				ALTPWM15[11:8]				
0xBF	ALTPWM15		-	-	-	-	ALTPWM15[11:8]				
0xC0	E2ADDR	EEPROM Read/Write Access	E2ADDR[6:0]				E2ADDR[6:0]				
0xC1	E2CTRLSTA		E2BUSY	BLDACT	E2ERR	-	-	RWCTRL[2:0]			





**Atmel Corporation**

2325 Orchard Parkway  
San Jose, CA 95131  
USA

**Tel:** (+1)(408) 441-0311

**Fax:** (+1)(408) 487-2600

[www.atmel.com](http://www.atmel.com)

**Atmel Asia Limited**

Unit 01-5 & 16, 19F  
BEA Tower, Millennium City 5  
418 Kwun Tong Road  
Kwun Tong, Kowloon  
HONG KONG

**Tel:** (+852) 2245-6100

**Fax:** (+852) 2722-1369

**Atmel Munich GmbH**

Business Campus  
Parking 4  
D-85748 Garching b. Munich  
GERMANY

**Tel:** (+49) 89-31970-0

**Fax:** (+49) 89-3194621

**Atmel Japan**

9F, Tonetsu Shinkawa Bldg.  
1-24-8 Shinkawa  
Chuo-ku, Tokyo 104-0033  
JAPAN

**Tel:** (+81)(3) 3523-3551

**Fax:** (+81)(3) 3523-7581

© 2012 Atmel Corporation. All rights reserved. / Rev.: MEM-MSL2160/61DB1-E-US\_06-11

Atmel®, logo and combinations thereof, and others are registered trademarks or trademarks of Atmel Corporation or its subsidiaries. Other terms and product names may be trademarks of others.

Disclaimer: The information in this document is provided in connection with Atmel products. No license, express or implied, by estoppel or otherwise, to any intellectual property right is granted by this document or in connection with the sale of Atmel products. EXCEPT AS SET FORTH IN THE ATMEL TERMS AND CONDITIONS OF SALES LOCATED ON THE ATMEL WEBSITE, ATMEL ASSUMES NO LIABILITY WHATSOEVER AND DISCLAIMS ANY EXPRESS, IMPLIED OR STATUTORY WARRANTY RELATING TO ITS PRODUCTS INCLUDING, BUT NOT LIMITED TO, THE IMPLIED WARRANTY OF MERCHANTABILITY, FITNESS FOR A PARTICULAR PURPOSE, OR NON-INFRINGEMENT. IN NO EVENT SHALL ATMEL BE LIABLE FOR ANY DIRECT, INDIRECT, CONSEQUENTIAL, PUNITIVE, SPECIAL OR INCIDENTAL DAMAGES (INCLUDING, WITHOUT LIMITATION, DAMAGES FOR LOSS AND PROFITS, BUSINESS INTERRUPTION, OR LOSS OF INFORMATION) ARISING OUT OF THE USE OR INABILITY TO USE THIS DOCUMENT, EVEN IF ATMEL HAS BEEN ADVISED OF THE POSSIBILITY OF SUCH DAMAGES. Atmel makes no representations or warranties with respect to the accuracy or completeness of the contents of this document and reserves the right to make changes to specifications and products descriptions at any time without notice. Atmel does not make any commitment to update the information contained herein. Unless specifically provided otherwise, Atmel products are not suitable for, and shall not be used in, automotive applications. Atmel products are not intended, authorized, or warranted for use as components in applications intended to support or sustain life.