

Atmel LED Driver-MSLB9082 LED Backlight Driver Module

Compact, 8-channel, 20W LED Driver Board with I²C Interface

Datasheet



Atmel LED Driver-MSLB9082 LED Backlight Driver Module

Compact, 8-channel, 20W LED Driver Board with I²C Interface

General Description

The Atmel® compact, 8-channel LED driver board is a complete LED backlight driver solution using the Atmel LED Driver-MSL3162 for medium-sized LCD panels. Each channel drives up to 10 series-connected LEDs at up to 160mA per channel. The driver board is configured to operate from a 10 - 16V input voltage. The full-scale LED current is preset to 50, 60, 70, or 80mA per LED string, selected by an onboard switch. Current can be reduced from full scale through the I²C serial interface in 64 linear steps. Digital (PWM) dimming is available through an external signal or by using the internal PWM generator via the serial interface.

The optional microcontroller board and graphical user interface (GUI) software allow control of the driver board through a personal computer. This gives access to the internal features of the MSL3162, including fault detection, digital control of LED current, individual LED string on/off control, and internally generated PWM dimming.

The compact eight-channel LED driver board is intended for evaluation, prototyping, or small production runs. Gerber files and Cadence OrCAD layout files are available to allow the circuit to be integrated into a larger system for large production runs.

Applications

- LCD Panel LED Backlight Driver

Ordering Information

PART	DESCRIPTION
MSLB9082	Compact, 8-channel LED driver module

Atmel LED Driver-MSLB9082 LED Backlight Driver Module

Compact, 8-channel, 20W LED Driver Board with I²C Interface

Key Features

- Drives Up to 8LED Strings
- Up to 10 LEDs per String
- Up to 160mA per LED string
- Internally Generated PWM Dimming
- I²C Serial Interface
- Fault Detection and Protection
- 10 To 16V Input Voltage Range
- Up To 20W Output Power
- Small Size, 1.0" X 2.0"
- Four Available I²C Slave Addresses, Switch Selectable
- Four Full-scale Current Settings, Switch Selectable
- Four Available Voltage Ranges To Support Multiple Panels
- 1.4mhz Switching Frequency
- Internal or External PWM Dimming Control
- Digital Control Of LED String Current
- Individual LED String On/Off Digital Control
- Short Circuit Or Open Circuit LED String Detection
- Automatic Over-voltage Protection

LED Driver Board

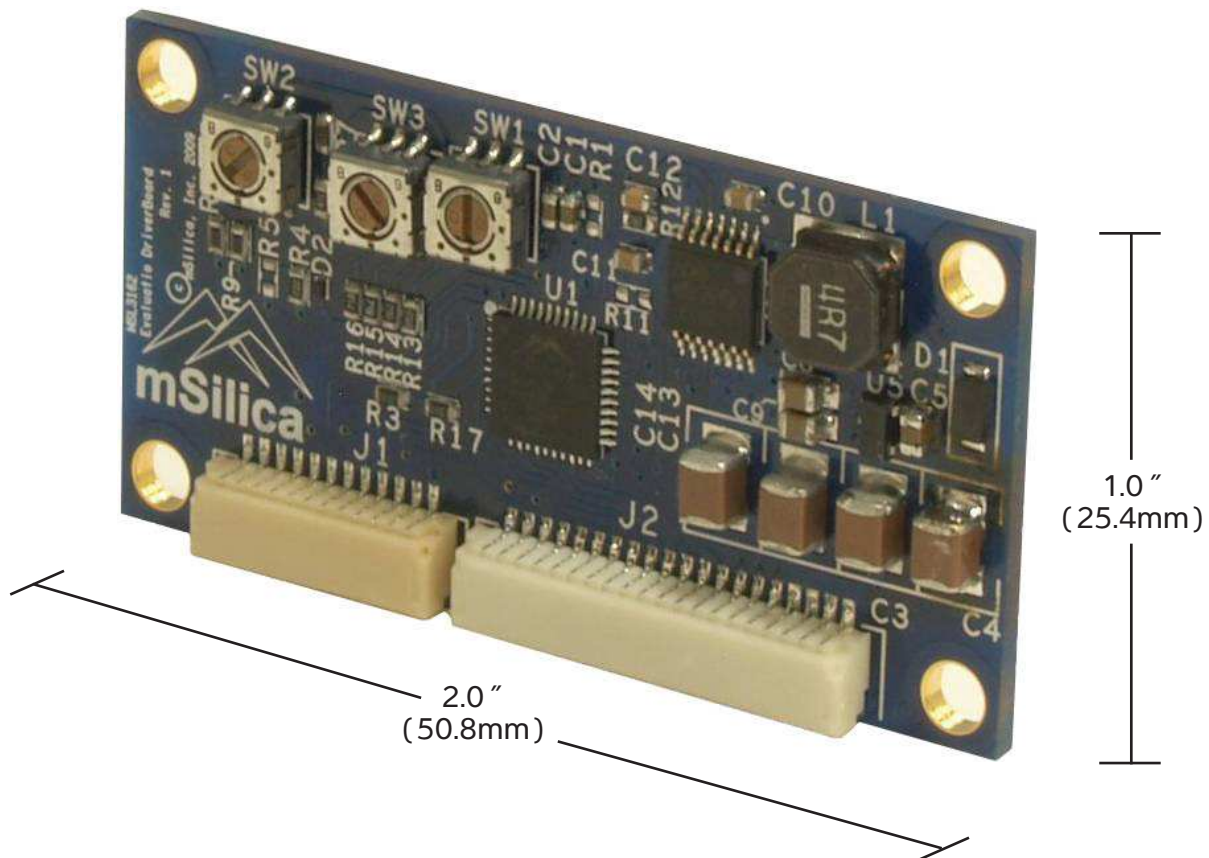



Mechanical Drawing

Figure 1. Atmel LED Driver-MSLB9082 Mechanical Drawing. All Dimensions in Inches.

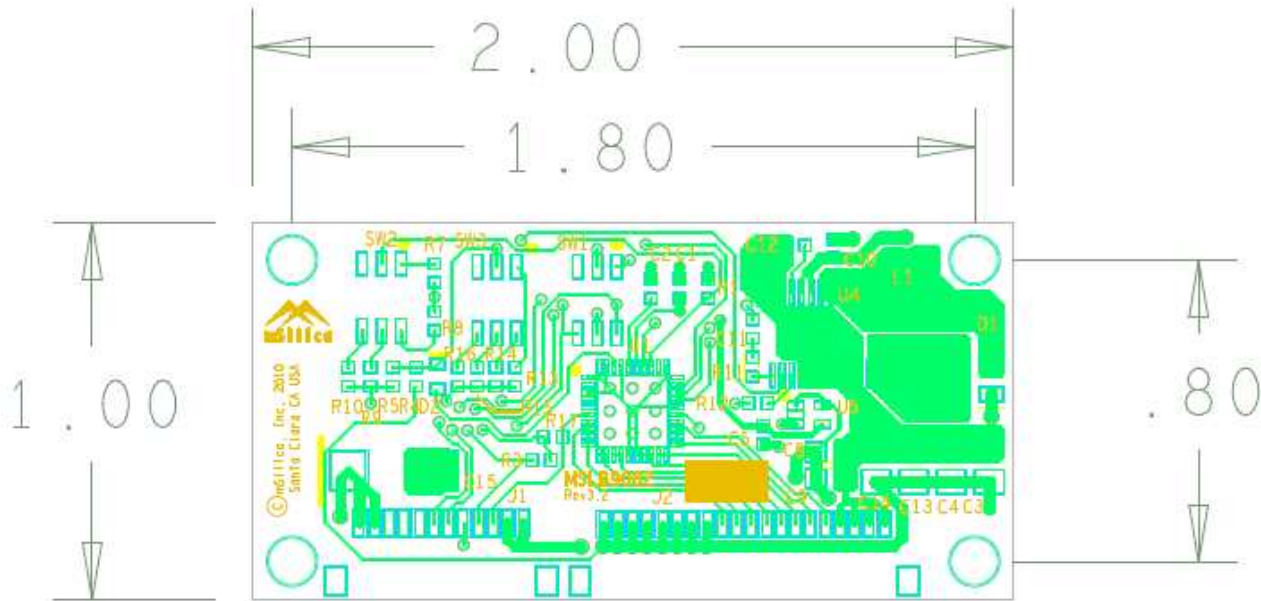

Connector Pin Descriptions

Table 1. J2 Input Connector Pin Descriptions

PIN NAME	PIN NUMBER	PIN DESCRIPTION
PWR	1,2	Input power to integrated boost regulator circuit
NC	3	No connection
NC	4	No connection
NC	5	No connection
SDA	6	I ² C serial data
SCL	7	I ² C serial clock
FLT_B	8	Active low fault indication output
EN	9	Enable control input
PWM	10	PWM dimming control input
GND	11,12	Ground

Table 2. J3 Output Connector Pin Descriptions

Atmel LED Driver-MSLB9082

LED Backlight Driver Module

Compact, 8-channel, 20W LED Driver Board with I²C Interface

PIN NAME	PIN NUMBER	PIN DESCRIPTION
VLED	1-8	LED string anode output voltage
STRA	9	LED string A cathode connection (MSL3162 STR0 and STR1)
STRB	10	LED string B cathode connection (MSL3162 STR2 and STR3)
STRC	11	LED string C cathode connection (MSL3162 STR4 and STR5)
STRD	12	LED string D cathode connection (MSL3162 STR6 and STR7)
STRE	13	LED string E cathode connection (MSL3162 STR8 and STR9)
STRF	14	LED string F cathode connection (MSL3162 STR10 and STR11)
STRG	15	LED string G cathode connection (MSL3162 STR12 and STR13)
STRH	16	LED string H cathode connection (MSL3162 STR14 and STR15)
GND	17-20	Ground

Absolute Maximum Ratings

Voltage (With Respect to GND)

STR1-STR6	-0.3V to +40V
VLED	-0.3V to +40V
PWR	-0.3V to +25V
EN, PWM, SDA, SCL, FLTB	-0.3V to +5.5V
Ambient operating temperature range $T_A = T_{MIN}$ to T_{MAX}	-40°C to +50°C

Table 3: Electrical Operating Characteristics

(Typical application circuit, $V_{IN} = 12V$, $T_A = T_{MIN}$ to T_{MAX} unless otherwise noted. Typical values are at $T_A = +25°C$)

PARAMETER	CONDITIONS AND NOTES	MIN	TYP	MAX	UNIT
DC ELECTRICAL CHARACTERISTICS					
Power input voltage		10		16	V
EN logic input high level		2.3			V
EN logic input low level				0.8	V
PWM, SDA, SCL input high voltage		2			V
PWM, SDA, SCL input low voltage				0.9	V
FLTB output low voltage	$I_{FLTB} = 1mA$			0.1	V
FLTB leakage current	$V_{FLTB} = 3.6V$			1	uA
STR1-STR8 output current	ISTRn = 0x3F, S2 position 1		50		mA
	ISTRn = 0x3F, S2 position 2		60		mA
	ISTRn = 0x3F, S2 position 3		70		mA
	ISTRn = 0x3F, S2 position 4		80		mA



PARAMETER	CONDITIONS AND NOTES	MIN	TYP	MAX	UNIT
AC ELECTRICAL CHARACTERISTICS					
PWM input frequency				20	kHz

PARAMETER	CONDITIONS AND NOTES	MIN	TYP	MAX	UNIT
I²C SWITCHING CHARACTERISTICS					
SCL clock frequency	I ² C timeout disabled (Note 1)			1000	kHz
Bus timeout			25		ms
Bus free time between a STOP and START condition		0.5			μs
Hold time for a repeated START condition		0.26			μs
Set-up time for a repeated START condition		0.26			μs
Set-up time for STOP condition		0.26			μs
Data hold time		10			ns
Data valid acknowledge time	(Note 2)	0.05		0.45	μs
Data valid time	(Note 3)	0.05		0.45	μs
Data set-up time		100			ns
LOW period of the SCL clock		0.5			μs
HIGH period of the SCL clock		0.26			μs
Fall time of SDA and SCL signals	(note 4,5)			120	ns
Rise time of both SDA and SCL signals				120	ns
Pulse width of spikes that must be suppressed by the input filter	(Note 6)		50		ns
SDA, SCL, AD0 input capacitance			10		pF

Note 1. Minimum SCL clock frequency is limited by the bus timeout feature, which resets the serial bus interface if either SDA or SCL is held low for 25ms. Disable bus timeout feature for DC operation.

Note 2. Time for acknowledge signal from SCL low to SDA (out) low.

Note 3. Minimum time for SDA data out to be valid following SCL low.

Note 4. A master device must internally provide a hold time of at least 300ns for the SDA signal (refer to the V_{IL} of the SCL signal) in order to bridge the undefined region of SCL falling edge.

Note 5. The maximum fall times for the SDA and SCL bus lines are specified at 300ns. The maximum fall time for the SDA output stage is specified at 250ns. This allows series protection resistors to be connected between SDA and SCL and the SDA/SCL bus lines without exceeding the maximum specified fall time.

Note 6. Input filters on the SDA, SCL, and AD0 inputs suppress noise less than 50ns

Atmel LED Driver-MSLB9082 LED Backlight Driver Module

Compact, 8-channel, 20W LED Driver Board with I²C Interface

Typical Performance Characteristics

String Phasing

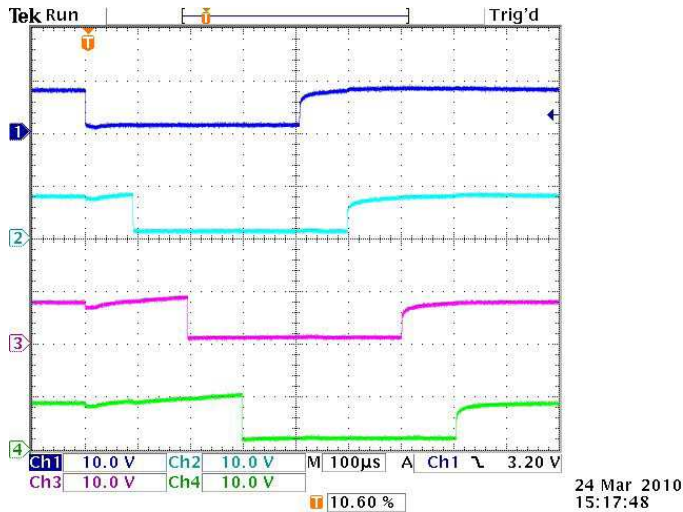

EFFICIENCY vs. STRING CURRENT

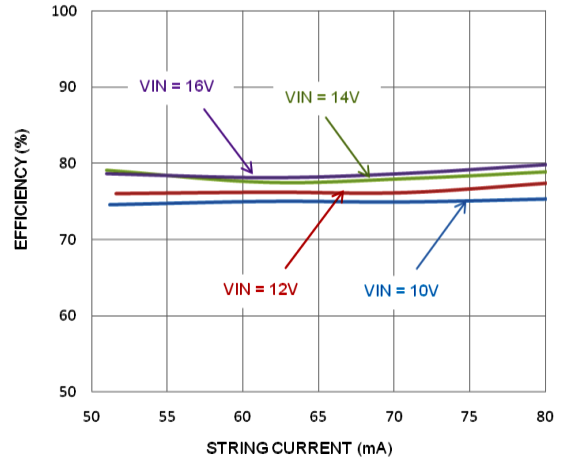

MAXIMUM LED POWER vs. SUPPLY VOLTAGE

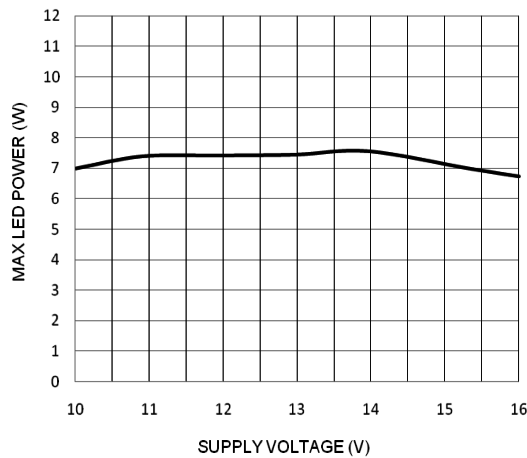

Efficiency Optimizer Initial Calibration

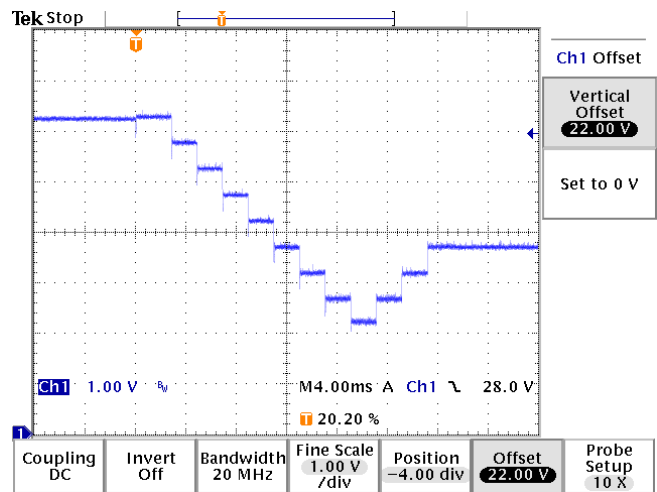



Typical Performance Characteristics (Continued)

Efficiency Optimizer Auto Recalibration

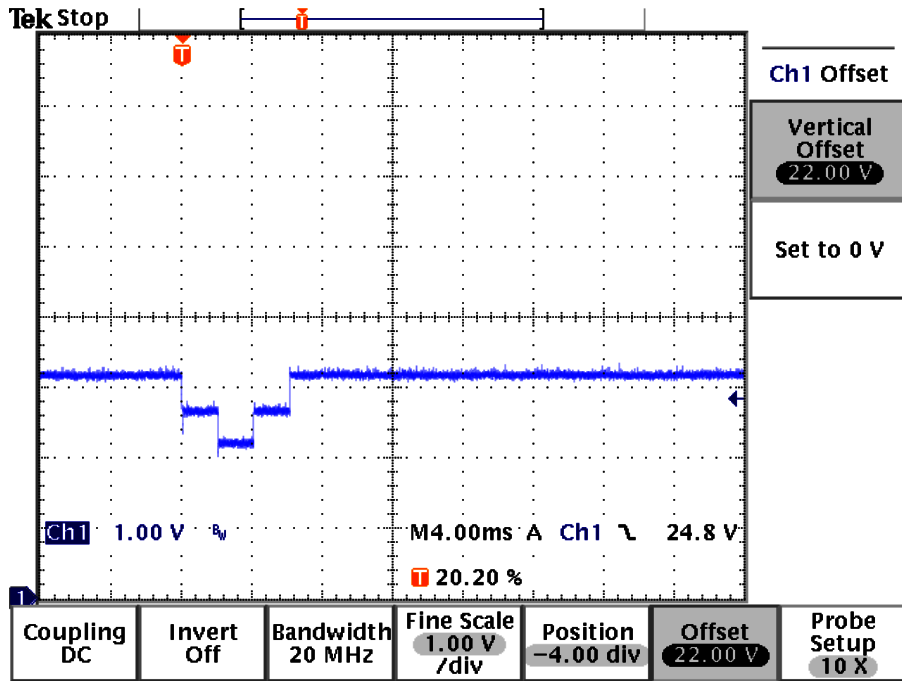

Detailed Description

The MSLB9082 is a stand-alone, eight-channel LED driver board suitable for integration into small-production devices. It includes an I²C serial interface for accessing the digital features of the MSL3162 LED driver. It has onboard switches that set the I²C slave address to one of four available addresses, a switch to set the full-scale LED current to 50, 60, 70, or 80mA in single-string mode, and 100, 120, 140, or 160mA in dual-string mode, and a switch to set the maximum LED voltage to 39, 36, 32, or 28V. The board is powered from a single input voltage between 10V and 16V.

Input Power

The MSLB9082 board is powered from a single input voltage ranging from 10 to 16V.

Setting the Full-scale LED Current

The MSL3162 regulates the LED string current. The LED string current is set by a current sense resistor. Four different values are programmed to the MSLB9082 LED driver module, and switch S2 selects one of those resistors to set the full-scale, per-string LED current to 50, 60, 70, or 80mA. Table 4 shows the switch settings and the full-scale, per-string LED current for each setting.

Table 4: Full-scale, Per-string LED Current (S2) Settings

Atmel LED Driver-MSLB9082

LED Backlight Driver Module

Compact, 8-channel, 20W LED Driver Board with I²C Interface

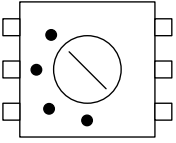
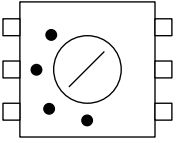
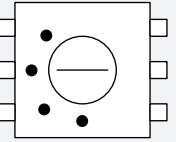
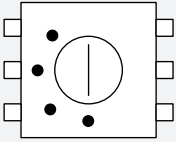
FULL-SCALE LED CURRENT SWITCH S2 POSITION	FULL-SCALE, PER-STRING LED CURRENT	FULL-SCALE LED CURRENT SWITCH S2 POSITION	FULL-SCALE, PER-STRING LED CURRENT
 Position 1	50mA	 Position 3	70mA
 Position 2	60mA	 Position 4	80mA

When using the I²C serial interface, the per-string LED current is changed from the full-scale value by programming the I_{STRn} register, where n is the LED string number from 0 to 15. The I_{STRn} register is a 6-bit word that sets the LED current for each LED string to one of 64 linear levels. The per-string LED current is:

$$I_{STRn} = I_{STR_FULL} \left(\frac{ISTRn+1}{64} \right),$$

where I_{STRn} is the current of LED string n , I_{STR_FULL} is the full-scale LED current set by S2, and $ISTRn$ is the value of the current setting register for string n between 0 and 64 (0x3F).



I²C Serial Interface

The MSLB9082 driver module uses an I²C/SMBus serial interface for digital LED control and fault detection. Four slave ID addresses are available, and are selected by the I²C address selection switch. The addresses are shown in table 5.

Table 5: I²C Slave Address Switch (S1) Settings

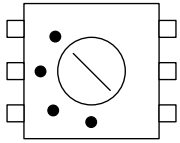
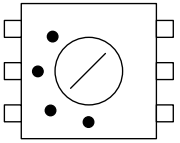
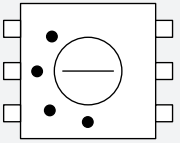
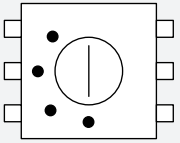
ADDRESS SWITCH S1 POSITION	I ² C SLAVE ADDRESS	ADDRESS SWITCH S1 POSITION	I ² C SLAVE ADDRESS
 Position 1	0xA0	 Position 3	0xA4
 Position 2	0xA6	 Position 4	0xA2

There are a number of features available through the I²C serial interface. Table 5 shows the registers for the MSL3162 LED driver.

Atmel LED Driver-MSLB9082

LED Backlight Driver Module

Compact, 8-channel, 20W LED Driver Board with I²C Interface

Table 6. Atmel LED Driver-MSL3162 Register Map

REGISTER	ADD-RESS	DEFAULT VALUES	FUNCTION	REGISTER DATA							
				D7	D6	D5	D4	D3	D2	D1	D0
CONTROL0	0x00	0x55	LED string enables	STR7EN	STR6EN	STR5EN	STR4EN	STR3EN	STR2EN	STR1EN	STR0EN
CONTROL1	0x01	0x55		STR15EN	STR14EN	STR13EN	STR12EN	STR11EN	STR10EN	STR9EN	STR8EN
POWERCTRL	0x02	0x7F	Fault configuration	SLEEP	-	SCEN	OCEN	0*	TOEN	FBEN	PHAEN
FLTSTATUS	0x03	RO	Fault status, global	0	SCDET	OCDET	0	0	0	FBOICAL	FLTDET
FLTMASK0	0x04	0xFF	Fault enables, string monitoring	FLTEN7	FLTEN6	FLTEN5	FLTEN4	FLTEN3	FLTEN2	FLTEN1	FLTEN0
FLTMASK1	0x05	0xFF		FLTEN15	FLTEN14	FLTEN13	FLTEN12	FLTEN11	FLTEN10	FLTEN9	FLTEN8
OCSTAT0	0x06	RO	Fault status, LED string open circuit	OC7	OC6	OC5	OC4	OC3	OC2	OC1	OC0
OCSTAT1	0x07	RO		OC15	OC14	OC13	OC12	OC11	OC10	OC9	OC8
SCSTAT0	0x08	RO	Fault status, LED string short circuit	SC7	SC6	SC5	SC4	SC3	SC2	SC1	SC0
SCSTAT1	0x09	RO		SC15	SC14	SC13	SC12	SC11	SC10	SC9	SC8
STRFB0	0x0A	0x55	LED string feed-back assignment to power supplies FBO1, FBO2, FBO3	STRFB3[1:0]		STRFB2[1:0]		STRFB1[1:0]		STRFB0[1:0]	
STRFB1	0x0B	0x55		STRFB7[1:0]		STRFB6[1:0]		STRFB5[1:0]		STRFB4[1:0]	
STRFB2	0x0C	0x55		STRFB11[1:0]		STRFB10[1:0]		STRFB9[1:0]		STRFB8[1:0]	
STRFB3	0x0D	0x55		STRFB15[1:0]		STRFB14[1:0]		STRFB13[1:0]		STRFB12[1:0]	
FBOCTRL0	0x10	0x00	Efficiency optimizer configuration	HLDSTEP[1:0]		FBCLDLY[1:0]		FBSLDLY[1:0]		FBCFDLY[1:0]	
FBOCTRL1	0x11	0x00		SCCDLY[1:0]		-	-	ACALPWM	ACALFSTR	ACALEN	TRIDIS
FBODAC1	0x12	RO	Efficiency optimizer DAC Readback	DSTAT1	0	0	0	FBODAC1[3:0]			
FBODAC2	0x13	RO		DSTAT2	0	0	0	FBODAC2[3:0]			
FBODAC3	0x14	RO		DSTAT3	0	0	0	FBODAC3[3:0]			
OSCCTRL	0x18	0x04	Oscillator frequency	-	-	-	-	-	OSC[2:0]		
IGSCGEN	0x1A	0xF9	GSC clock generator internal	IGSCGEN[7:0]							
	0x1B	0x00		IGSCGEN[15:8]							
IPHIGEN	0x1C	0x00	PHI clock generator internal	IPHIGEN[7:0]							
	0x1D	0x1F		IPHIGEN[15:8]							
PWMCTRL0	0x20	0xC0	PWM and phase control configuration	HPSCREN	GINTEN	PHIPOL	OTPDIGEN	PHIMINEN	GSCMAXEN	FSNOZSK	1*
PWMCTRL1	0x21	0x03		-	-	-	-	-	PWMMODE	INTPHI	INTGSC
SYSTEMP	0x22	0x00	System temperature	SYSTEMP[7:0]							
OTTEMP	0x23	0x00	Over-temp derating threshold	OTTEMP[7:0]							
OTSLOPE	0x24	0x00	Over-temp derating slope	OTSLOPE[7:0]							
GSCMAX	0x25	0x00	Max osc. cycles per GSC pulse	GSCMAX[7:0]							
	0x26	0x00		GSCMAX[15:8]							
PHIMIN	0x27	0x00	Min GSC pulses over PHI period	PHIMIN[7:0]							
	0x28	0x00		-	-	-	-	PHIMIN[15:8]			
HPSCR	0x29	0x00	GSC divider	-	-	-	-	HPSCR[3:0]			



Table 6. Atmel LED Driver - MSL3162 Register Map

REGISTER	ADD-RESS	DEFAULT VALUES	FUNCTION	REGISTER DATA						
				D7	D6	D5	D4	D3	D2	D1
FRATE	0x2A	0x01	PHI freq. multiplier	-	-	-	FRATE[4:0]			
GINT	0x2B	0x2B	Global intensity	-	-	GINT[6:0]				
ISTR0	0x30	0x20	LED string 6-bit individual analog current settings	-			ISTR0[5:0]			
To				to						
ISTR15	0x3F			-			ISTR15[5:0]			
PHDLY0	0x40	0x00	LED string 8-bit individual PWM phase settings	PHDLY0[7:0]						
PHDLY1	0x41	0x00		PHDLY1 [7:0]						
PHDLY2	0x42	0x20		PHDLY2[7:0]						
PHDLY3	0x43	0x20		PHDLY3[7:0]						
PHDLY4	0x44	0x40		PHDLY4[7:0]						
PHDLY5	0x45	0x40		PHDLY5[7:0]						
PHDLY6	0x46	0x60		PHDLY6[7:0]						
PHDLY7	0x47	0x60		PHDLY7[7:0]						
PHDLY8	0x48	0x80		PHDLY8[7:0]						
PHDLY9	0x49	0x80		PHDLY9[7:0]						
PHDLY10	0x4A	0xA0		PHDLY10[7:0]						
PHDLY11	0x4B	0xA0		PHDLY11[7:0]						
PHDLY12	0x4C	0xC0		PHDLY12[7:0]						
PHDLY13	0x4D	0xC0		PHDLY13[7:0]						
PHDLY14	0x4E	0xE0		PHDLY14[7:0]						
PHDLY15	0x4F	0xE0		PHDLY15[7:0]						
PWM0	0x50	0x30	LED string 8-bit individual PWM intensity settings	PWM0[7:0]						
to				To						
PWM15	0x5F			PWM15[7:0]						
Do not access address range 0x60 to 0x8F										
E2ADDR	0x90		User EEPROM read/write access	-	E2ADDR[6:0]					
E2CTRLSTA	0x91			E2BUSY	BLDACT	E2ERR	SLVATCNT[1:0]		RWCTRL[1:0]	

For detailed descriptions of the MSL3162 register-controlled operating modes, see the MSL3162 Datasheet.

Atmel LED Driver-MSLB9082

LED Backlight Driver Module

Compact, 8-channel, 20W LED Driver Board with I²C Interface

Setting the Internal PWM Dimming Frequency and Duty Cycle

The MSL3162 internally generates the PWM dimming duty cycle and frequency. The PWM dimming frequency is programmable, as are the PWM duty cycle and phasing between LED strings.

Setting the PWM Dimming Frequency

The PWM frequency (PHI frequency) is internally set by the IPHIGEN register. This 16-bit number sets the divider ratio from an internal 2.5MHz clock. Therefore, the PWM frequency is:

$$f_{PWM} = \frac{2.5MHz}{IPHIGEN}$$

For high dimming accuracy, keep the PWM dimming frequency below 10kHz. To set the PWM frequency, program the IPHIGEN register between 38Hz and 10kHz per the equation:

$$IPHIGEN = \frac{2.5MHz}{f_{PWM}}$$

where IPHIGEN ranges between 250 (0x00FA) and 65535 (0xFFFF)

For full PWM dimming resolution, make sure that the ratio between the IGSCGEN register and IPHIGEN register is 32. See Setting the PWM Dimming Resolution for more details.

Setting the PWM Dimming Resolution

The MSL3162 uses the IPHIGEN register to set the PWM dimming frequency, and it uses the IGSCGEN register to set the PWM dimming resolution (GSC frequency). The MSL3162 internally counts using the frequency set by the IGSCGEN register to set the PWM duty and phasing. Full PWM dimming is achieved if the ratio of IGSCGEN to IPHIGEN is less than 32. If the ratio is greater than 32, then the maximum achievable duty cycle is:

$$D_{MAX} = 32 \times \left(\frac{IGSCGEN - 1}{IPHIGEN} \right)$$

For $D_{MAX} > 1$, the maximum duty cycle is 100%.

Setting the LED PWM Dimming Duty Cycle

The MSL3162 allows each LED string to operate at different duty cycles and phases. The per-string PWM dimming duty cycle for any LED string is set by the PWMn register, where n is the LED string number. The MSL3162 also offers PWM dimming of all strings simultaneously through the global intensity (GINT) register. Each string PWM on time is set by the eight most-significant bits of the product of the PWMn and GINT registers, multiplied by the GSC period:

$$t_{ON_PWMn} = \left(\frac{1}{f_{GSC}} \right) * \left(\frac{PWMn * GINT}{64} \right)$$

$$t_{ON_PWMn} = \left(\frac{IGSCGEN - 1}{20 \text{ MHz}} \right) * \left(\frac{PWMn * GINT}{64} \right)$$

where PWMn ranges from 0 to 256 (0xFF) and GINT ranges from 0 to 64 (0x3F).

Setting the LED PWM Dimming Phasing

Each LED string's PWM dimming occurs with independent phasing. This is useful to force phase shifted PWM dimming, which reduces the transient load on the DC-DC converter, improving performance.

The phase of each LED string is set by PHDLYn, where n is the LED string number. The MSL3162 counts GSC pulses to determine the on-time delay from the beginning of each PHI frame. For example, if PHDLY0 is set to 0x00, the LED string 0 on time starts at the beginning of a PHI frame. If PHDLY0 is set to 0x40, the LED string 0 on time begins at 64 (0x40) GSC pulses after the beginning of a PHI frame.

$$t_{PHDLYn} = \left(\frac{1}{f_{GSC}} \right) * PHDLYn$$

$$t_{PHDLYn} = \left(\frac{IGSCGEN - 1}{20 \text{ MHz}} \right) * PHDLYn$$

Setting the LED Voltage Range

The MSL9082 LED driver board uses four different voltage ranges to power the LEDs, which are set through the S3 switch. The ranges are shown in Table 7. The MSL3162 automatically adjusts the LED voltage over a 7.4V range to minimize power loss while maintaining enough current sink headroom to keep the LED string current accurate. Choose an LED voltage range that suits the LEDs used so that the MSL3162 can adjust the voltage to optimize for the LED voltage. For more information, consult the MSL3162 data sheet.

Table 6: LED Voltage Settings

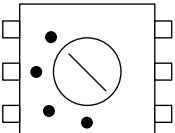
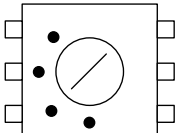
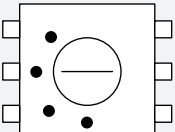
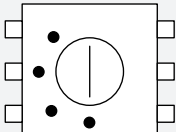
VOLTAGE SWITCH S3 POSITION	LED VOLTAGE RANGE	VOLTAGE SWITCH S3 POSITION	LED VOLTAGE RANGE
 <p>Position 1</p>	28.8V to 21.3V	 <p>Position 3</p>	37.1V to 29.6V
 <p>Position 2</p>	39.7V to 32.3V	 <p>Position 4</p>	33.0V to 25.6V

Atmel LED Driver-MSLB9082 LED Backlight Driver Module

Compact, 8-channel, 20W LED Driver Board with I²C Interface

On/Off (EN) Control Input

The on/off control input, pin 9 of input connector J2, turns on/off the LED driver. Drive it high (between 2.3 and 5V) to turn on the LED driver, and drive it low (0 to 0.8V) to turn it off. The on/off control input is internally pulled up by a 100k Ω resistor. For automatic start-up, leave EN unconnected.

External PWM Control Input

The MSL3162 operates in one of three modes: internal PWM mode, external PWM mode, or gated PWM mode. Internal PWM mode dims the LEDs with a frequency and phase set by the MSL3162, and the state of the PWM input is ignored and has no effect on LED brightness. In this case, each string can have a different PWM set by the MSL3162's PWM n register setting. To control the brightness of all LEDs simultaneously, set the GINT register between 0 and 3F.

External PWM and gated PWM modes use the duty cycle of the signal applied to the PWM input; connector J2, pin 10. The PWM input is pulled high through a 100k Ω resistor. If not used, leave PWM unconnected or drive it high. The MSL3162 digitizes the PWM input signal and determines the duty cycle of that signal. This value replaces the GINT register value to control the global brightness (of all LEDs simultaneously). In this case, individual string brightness is controlled through the PWM n register.

Gated PWM mode turns on all LEDs when PWM is driven high, and turns them off when PWM is driven low. By programming the PWM n registers and GINT for 100% duty cycle, the LEDs are directly PWM dimmed by the signal applied to the PWM input.

Fault Indicator Output

The MSL3162 includes fault detection circuitry that detects and open-circuited LED string, and an LED string with one or more short-circuited LEDs. If any fault is detected, the output is driven low. Use this output as an alert signal to a system controller. Once the controller gets the alert signal, it determines which LED is faulty by reading the STATUS, OCSTATUS, and SCSTATUS registers through the I²C serial interface.

Connecting the LEDs to the Atmel LED Driver-MSL9082 LED Driver

The MSLB9082 driver board drives LED arrays with up to eight parallel strings of up to 12 series LEDs each through the output connector, J3. Eight connections for LED cathode connections allow the use of separate LED strings or common-anode-connected LED strings.

Driving LEDs with Greater than 80mA LED Current

The MSL3162 is capable of driving up to 80mA per LED string. The MSLB9082 board has two string drivers connected to each driver connection (STR A -STR H), with one disabled. This allows driving up to 180mA per LED string by enabling the two drivers and setting the same PWM duty ratios and phasing for both MSL3162 driver inputs (dual-string mode). See the MSL3162 datasheet for more details on programming the MSL3162.

Table 8 shows the switch settings and the full-scale, per-string LED current for each setting when operating in parallel mode.

Table 8. Settings for Higher Currents

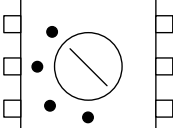
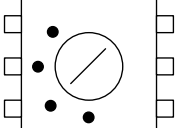
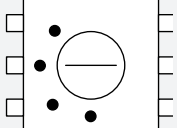
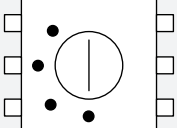
FULL-SCALE LED CURRENT SWITCH S2 POSITION	FULL-SCALE, PER-STRING LED CURRENT	FULL-SCALE LED CURRENT SWITCH S2 POSITION	FULL-SCALE, PER-STRING LED CURRENT
 <p>Position 1</p>	100mA	 <p>Position 3</p>	140mA
 <p>Position 2</p>	120mA	 <p>Position 4</p>	160mA

Atmel LED Driver-MSLB9082 LED Backlight Driver Module

Compact, 8-channel, 20W LED Driver Board with I²C Interface

Atmel LED Driver-MSLB9082 Schematic

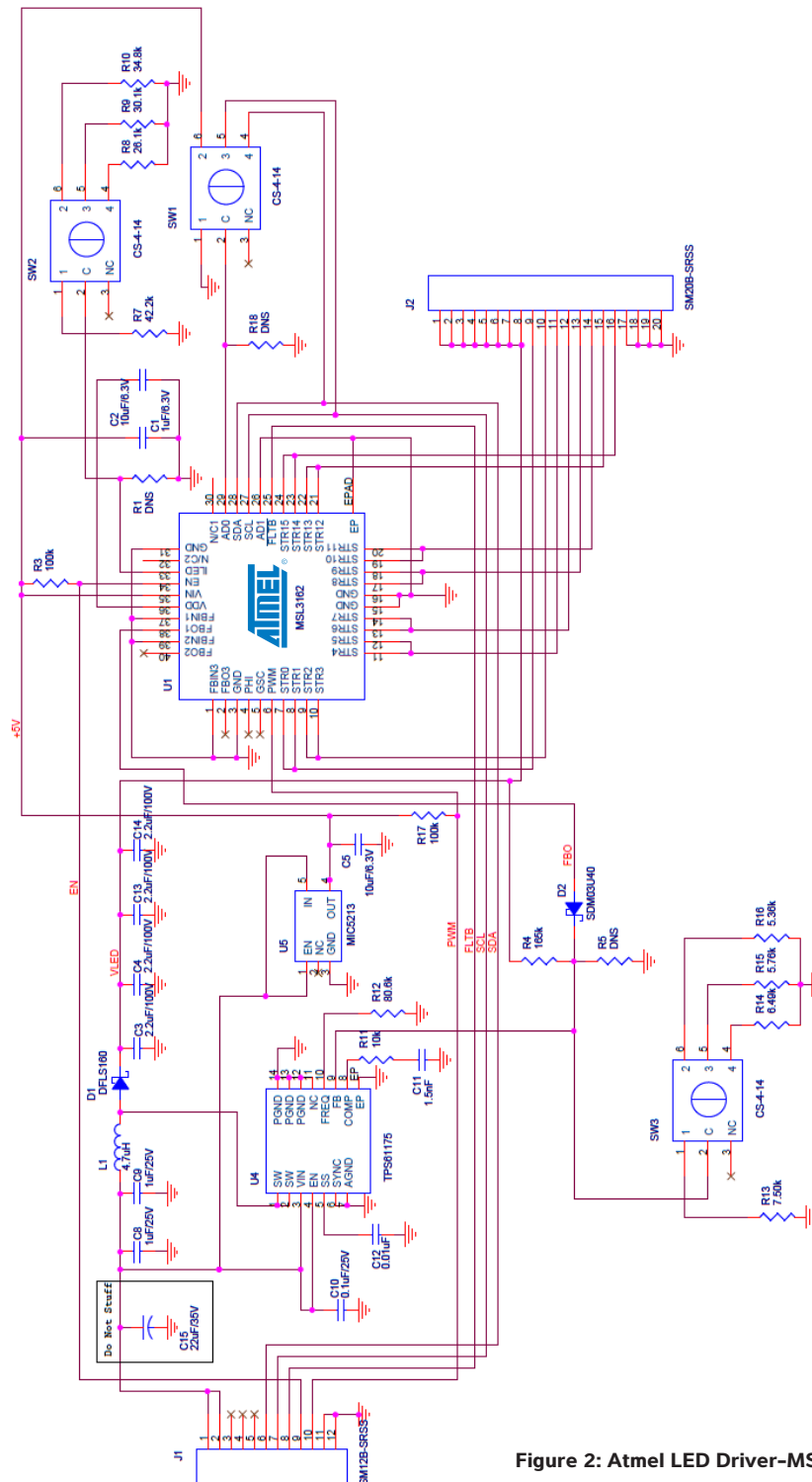

Figure 2: Atmel LED Driver-MSLB9082 Board Schematic.

Atmel LED Driver-MSLB9082 Component Placement

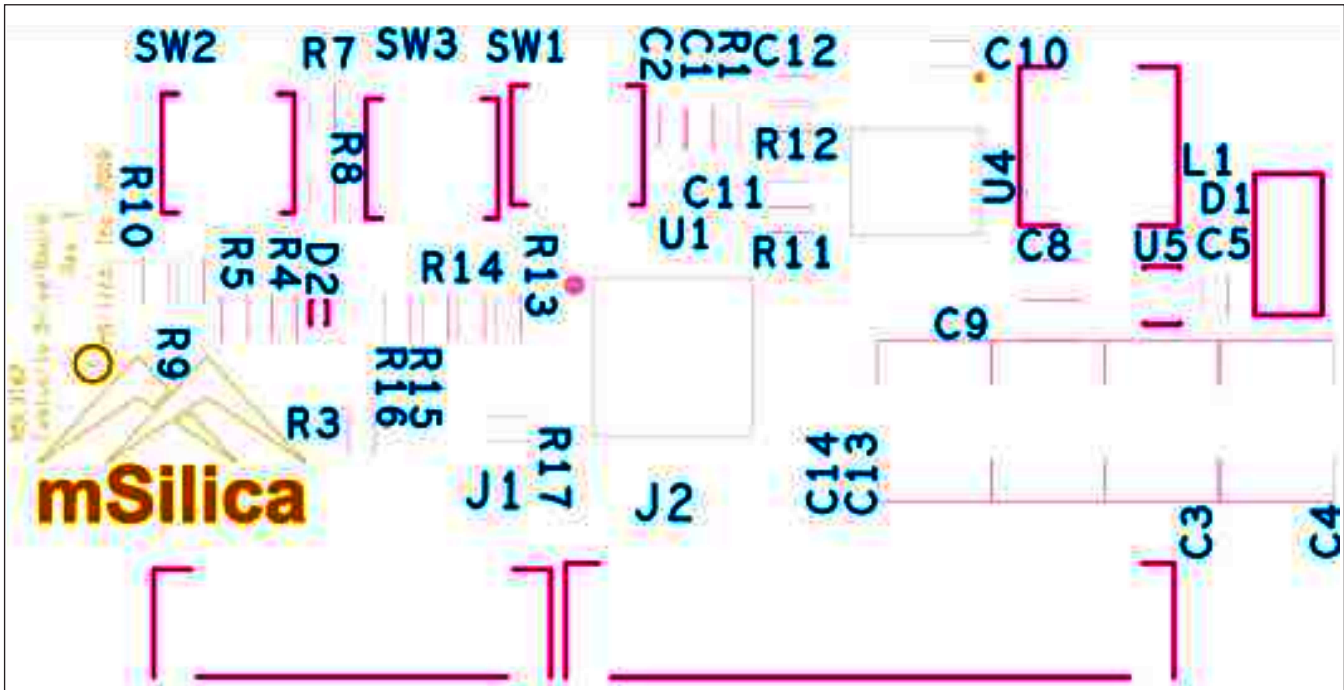

Figure 3: EVU-MSL3162-BLU1 Component Placement.

Atmel LED Driver-MSLB9082

LED Backlight Driver Module

Compact, 8-channel, 20W LED Driver Board with I²C Interface

Atmel LED Driver-MSLB9082 Bill of Materials

Atmel LED Driver-MSL3162 LED driver board revised: Wednesday, October 7, 2009

Revision: 3

ITEM	QUANTITY	REFERENCE	PART
1	1	C1	1 μ F/6.3V
2	1	C2	4.7 μ F/6.3V
3	4	C3,C4,C13,C14	2.2 μ F/100V
4	1	C5	2.2 μ F
5	2	C8,C9	1 μ F/25V
6	1	C10	0.1 μ F/25V
7	1	C11	3.3nF
8	1	C12	0.01 μ F
9	1	D1	Schottky rectifier, Diodes DLFS140
10	1	D2	Schottky rectifier, Central CMAD6263
11	1	J1	12-position connector, JST SM12B-SRSS
12	1	J2	20-position connector, JST SM20B-SRSS
13	1	L1	5.6uH inductor, Sumida CDRH5D20-5R6
14	2	R1,R5	Do Not Stuff
15	1	R3	100k Ω
16	1	R4	165k Ω
17	1	R7	42.2k Ω
18	1	R8	26.1k Ω
19	1	R9	30.1k Ω
20	1	R10	34.8k Ω
21	1	R11	4.7k Ω
22	1	R12	80k Ω
23	1	R13	7.50k Ω
24	1	R14	6.49k Ω
25	1	R15	5.76k Ω
26	1	R16	5.36k Ω
27	3	SW1,SW2,SW3	4-position switch, Copal CS-4-14
28	1	U1	16-channel LED driver, MSL3162
29	1	U3	5V regulator, Micrel MIC5233
30	1	U4	Boost regulator, TI TPS61175

**Atmel Corporation**

2325 Orchard Parkway
San Jose, CA 95131
USA

Tel: (+1)(408) 441-0311

Fax: (+1)(408) 487-2600

www.atmel.com

Atmel Asia Limited

Unit 01-5 & 16, 19F
BEA Tower, Millennium City 5
418 Kwun Tong Road
Kwun Tong, Kowloon
HONG KONG

Tel: (+852) 2245-6100

Fax: (+852) 2722-1369

Atmel Munich GmbH

Business Campus
Parking 4
D-85748 Garching b. Munich
GERMANY

Tel: (+49) 89-31970-0

Fax: (+49) 89-3194621

Atmel Japan

9F, Tonetsu Shinkawa Bldg.
1-24-8 Shinkawa
Chuo-ku, Tokyo 104-0033
JAPAN

Tel: (+81)(3) 3523-3551

Fax: (+81)(3) 3523-7581

© 2011 Atmel Corporation. All rights reserved. / Rev.: MEM-MSLB9082DS1-E-US_06-11

Atmel®, logo and combinations thereof, and others are registered trademarks or trademarks of Atmel Corporation or its subsidiaries. Other terms and product names may be trademarks of others.

Disclaimer: The information in this document is provided in connection with Atmel products. No license, express or implied, by estoppel or otherwise, to any intellectual property right is granted by this document or in connection with the sale of Atmel products. EXCEPT AS SET FORTH IN THE ATMEL TERMS AND CONDITIONS OF SALES LOCATED ON THE ATMEL WEBSITE, ATMEL ASSUMES NO LIABILITY WHATSOEVER AND DISCLAIMS ANY EXPRESS, IMPLIED OR STATUTORY WARRANTY RELATING TO ITS PRODUCTS INCLUDING, BUT NOT LIMITED TO, THE IMPLIED WARRANTY OF MERCHANTABILITY, FITNESS FOR A PARTICULAR PURPOSE, OR NON-INFRINGEMENT. IN NO EVENT SHALL ATMEL BE LIABLE FOR ANY DIRECT, INDIRECT, CONSEQUENTIAL, PUNITIVE, SPECIAL OR INCIDENTAL DAMAGES (INCLUDING, WITHOUT LIMITATION, DAMAGES FOR LOSS AND PROFITS, BUSINESS INTERRUPTION, OR LOSS OF INFORMATION) ARISING OUT OF THE USE OR INABILITY TO USE THIS DOCUMENT, EVEN IF ATMEL HAS BEEN ADVISED OF THE POSSIBILITY OF SUCH DAMAGES. Atmel makes no representations or warranties with respect to the accuracy or completeness of the contents of this document and reserves the right to make changes to specifications and products descriptions at any time without notice. Atmel does not make any commitment to update the information contained herein. Unless specifically provided otherwise, Atmel products are not suitable for, and shall not be used in, automotive applications. Atmel products are not intended, authorized, or warranted for use as components in applications intended to support or sustain life.