

## Features

- Full-wave Current Sensing
- Mains Supply Variation Compensated
- Programmable Load-current Limitation with Over- and High-load Output
- Variable Soft Start
- Voltage and Current Synchronization
- Automatic Retriggering Switchable
- Triggering Pulse Typically 125mA
- Internal Supply-voltage Monitoring
- Current Requirement  $\leq 3\text{mA}$
- Temperature-compensated Reference Voltage

## Applications

- Advanced Motor Control
- Grinder
- Drilling Machine

## 1. Description

The U2010B is designed as a phase-control circuit in bipolar technology for motor control applications with load-current feedback and overload protection. It enables load-current detection and has a soft-start function as well as reference voltage output.

Figure 1-1. Block Diagram

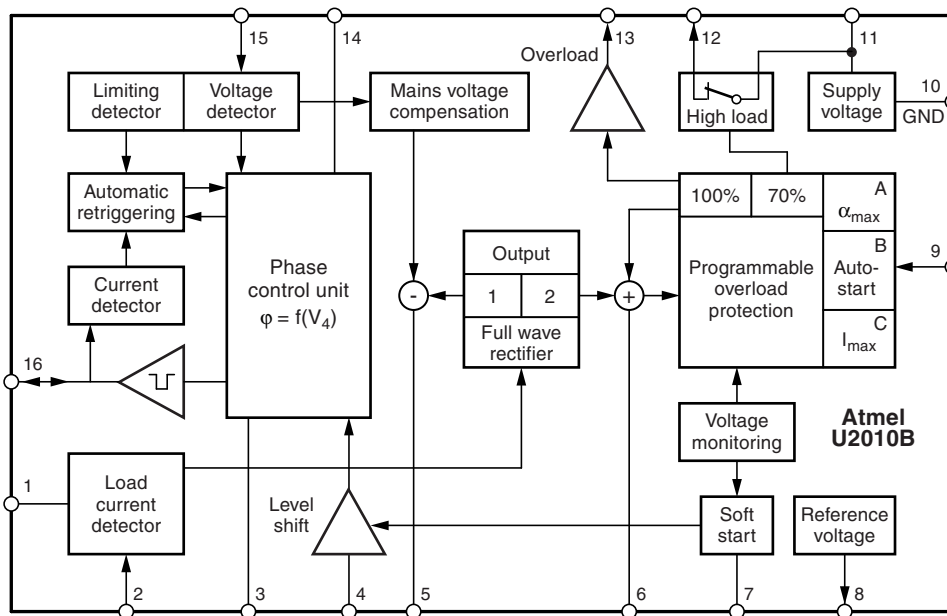

## Phase-control IC with Current Feedback and Overload Protection

## Atmel U2010B



**Figure 1-2. Block Diagram with External Circuit**

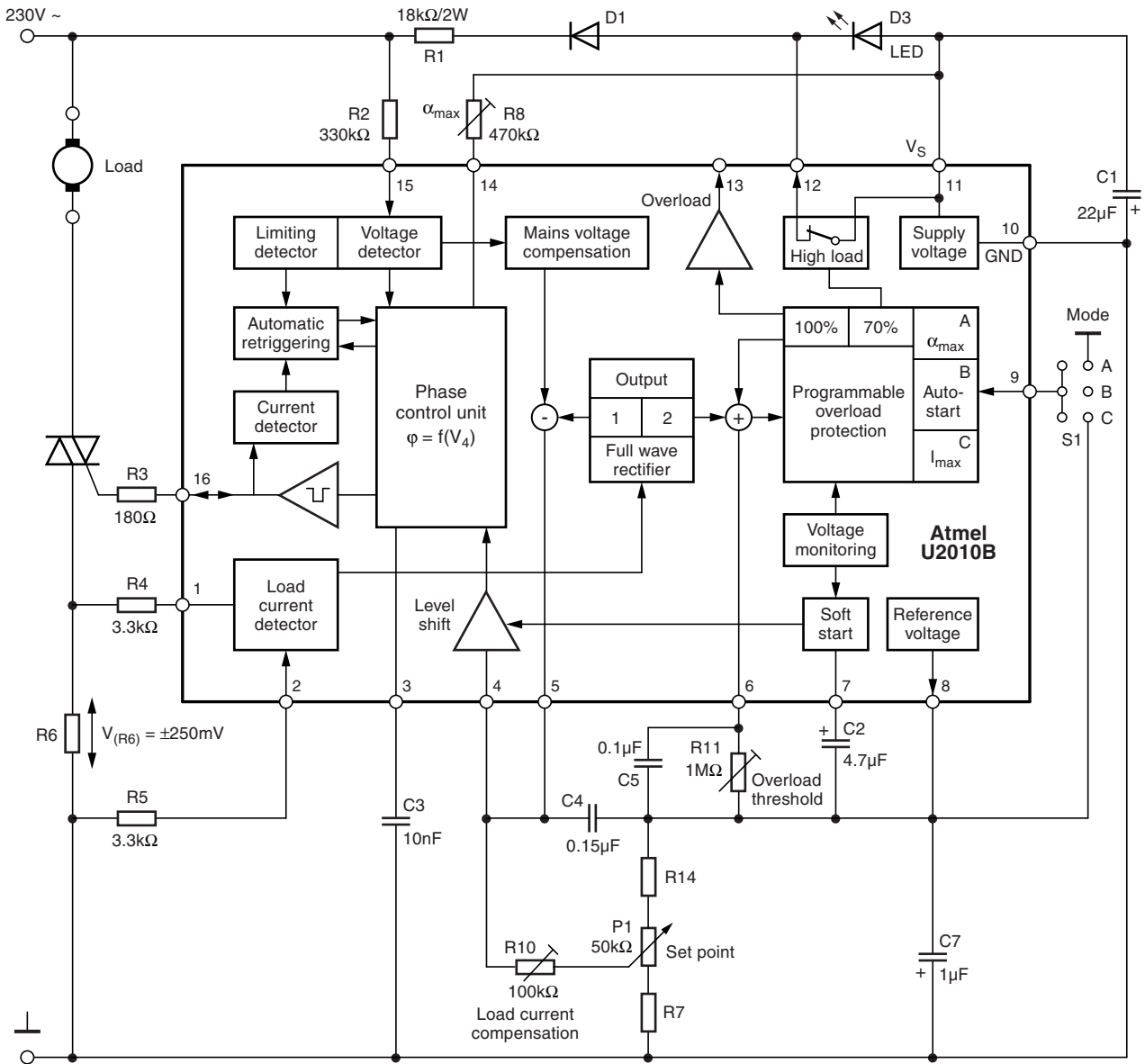

## 2. Pin Configuration

Figure 2-1. Pinning DIP16/SO16

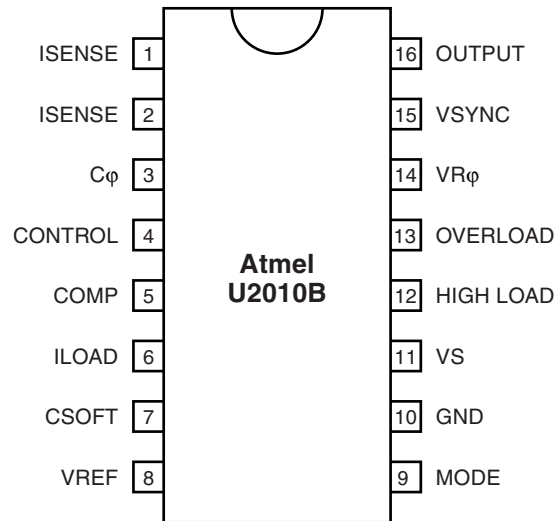

Table 2-1. Pin Description

Pin	Symbol	Function
1	ISENSE	Load current sensing
2	ISENSE	Load current sensing
3	C $\phi$	Ramp voltage
4	CONTROL	Control input
5	COMP	Compensation output
6	ILOAD	Load current limitation
7	CSOFT	Soft start
8	VREF	Reference voltage
9	MODE	Mode selection
10	GND	Ground
11	VS	Supply voltage
12	HIGH LOAD	High load indication
13	OVERLOAD	Overload indication
14	VR $\phi$	Ramp current adjust
15	VSYNC	Voltage synchronization
16	OUTPUT	Trigger output

### 3. General Description

#### 3.1 Mains Supply

The Atmel® U2010B contains voltage limiting and can be connected with the mains supply via  $D_1$  and  $R_1$ . Supply voltage – between pin 10 and pin 11 – is smoothed by  $C_1$ .

In the case of  $V_6 \leq 70\%$  of the overload threshold voltage, pins 11 and 12 are connected internally whereby  $V_{\text{sat}} \leq 1.2\text{V}$ . When  $|V_6| \geq |V_{T70}|$ , the supply current flows across  $D_3$ .

The series resistance  $R_1$  can be calculated as follows:

$$R_{1\text{max}} = \frac{V_{\text{mains}} - V_{\text{Smax}}}{2 \times I_{\text{tot}}}$$

where:

$V_{\text{mains}}$  = Mains supply voltage

$V_{\text{Smax}}$  = Maximum supply voltage

$I_{\text{tot}}$  = Total current consumption =  $I_{\text{Smax}} + I_x$

$I_{\text{Smax}}$  = Maximum current consumption of the IC

$I_x$  = Current consumption of the external components

#### 3.2 Voltage Monitoring

When the voltage is built up, uncontrolled output pulses are avoided by internal voltage monitoring. Apart from that, all latches in the circuit (phase control, load limit regulation) are reset and the soft-start capacitor is short-circuited. This guarantees a specified start-up behavior each time the supply voltage is switched on or after short interruptions of the mains supply. Soft start is initiated after the supply voltage has been built up. This behavior guarantees a gentle start-up for the motor and automatically ensures the optimum run-up time.

#### 3.3 Phase Control

The function of the phase control is mainly identical to the well-known IC U211B. The phase angle of the trigger pulse is derived by comparing the ramp voltage  $V_3$ , which is mains-synchronized by the voltage detector, with the set value on the control input, pin 4. The slope of the ramp is determined by  $C_\phi$  and its charging current  $I_\phi$ . The charging current can be varied using  $R_\phi$  at pin 14. The maximum phase angle,  $\alpha_{\text{max}}$ , can also be adjusted by using  $R_\phi$  (minimum current flow angle  $\phi_{\text{min}}$ ), see [Figure 7-1 on page 10](#).

When the potential on pin 3 reaches the set point level of pin 4, a trigger pulse width,  $t_p$ , is determined from the value of  $C_\phi$  ( $t_p = 9\mu\text{s}/n\text{F}$ ). At the same time, a latch is set with the output pulse as long as the automatic retriggering has not been activated. When this happens, no more pulses can be generated in that half cycle. The control input at pin 4 (with respect to pin 10) has an active range from  $V_8$  to  $-1\text{V}$ . When  $V_4 = V_8$ , then the phase angle is at its maximum,  $\alpha_{\text{max}}$ , i.e., the current flow angle is minimum. The minimum phase angle,  $\alpha_{\text{min}}$ , is set with  $V_4 \geq -1\text{V}$ .

## 3.4 Automatic Retriggering

The current-detector circuit monitors the state of the triac after triggering by measuring the voltage drop at the triac gate. A current flow through the triac is recognized when the voltage drop exceeds a threshold level of typically 40mV.

If the triac is quenched within the relevant half-wave after triggering (for example owing to low load currents before or after the zero crossing of the current wave, or for commutator motors, owing to brush lifters), the automatic retriggering circuit ensures immediate retriggering, if necessary with a high repetition rate,  $t_{pp}/t_p$ , until the triac remains reliably triggered.

## 3.5 Current Synchronization

Current synchronization fulfils two functions:

- Monitoring the current flow after triggering.  
In case the triac extinguishes again or does not switch on, automatic triggering is activated until the triggering is successful.
- Avoiding triggering due to an inductive load.  
In the case of inductive load operation, the current synchronization ensures that in the new half wave, no pulse will be enabled as long as there is a current available from the previous half wave, which flows from the opposite polarity to the actual supply voltage.

The current synchronization as described above is a special feature of the Atmel® U2010B. The device evaluates the voltage at the pulse output between gate and reference electrode of the triac. As a result, no separate current synchronization input with specified series resistance is necessary.

## 3.6 Voltage Synchronization with Mains Voltage Compensation

The voltage detector synchronizes the reference ramp with the mains supply voltage. At the same time, the mains-dependent input current at pin 15 is shaped and rectified internally. This current activates the automatic retriggering and at the same time is available at pin 5. By suitable dimensioning, it is possible to obtain the specified compensation effect. Automatic retriggering and mains voltage compensation are not activated until  $|V_{15-10}|$  increases to 8V. The resistance  $R_{sync}$  defines the width of the zero voltage cross over pulse, synchronization current, and hence the mains supply voltage compensation current.

**Figure 3-1.** Suppression of Mains Voltage Compensation and Automatic Retrigger

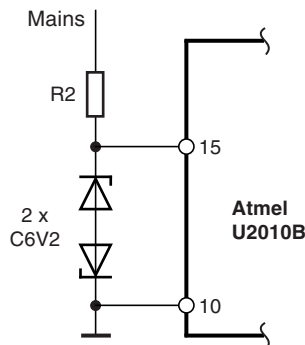

If the mains voltage compensation and the automatic retriggering are not required, both functions can be suppressed by limiting  $|V_{15-10}| \leq 7V$ , see [Figure 3-1](#).

### 3.7 Load-current Compensation

The circuit continuously measures the load current as a voltage drop at resistance  $R_6$ . The evaluation and use of both half waves results in a quick reaction to load-current change. Due to the voltage at resistance  $R_6$ , there is a difference between both input currents at pins 1 and 2. This difference controls the internal current source, whose positive current values are available at pins 5 and 6. The output current generated at pin 5 contains the difference from the load-current detection and from the mains voltage compensation, see [Figure 1-2 on page 2](#).

The efficient impedance of the set-point network generates a voltage at pin 4. A current, flowing out of pin 5 through  $R_{10}$ , modulates this voltage. An increase of mains voltage causes the increase of control angle  $\alpha$ , an increase of load current results in a decrease in the control angle. This avoids a decrease in revolution by increasing the load as well as an increase of revolution by the increment of the mains supply voltage.

### 3.8 Load-current Limitation

The total output load current is available at pin 6. It results in a voltage drop across  $R_{11}$ . When the potential of the load current reaches about 70% of the threshold value ( $V_{T70}$ ), i.e., about 4.35V at pin 6, it switches the high-load comparator and opens the switch between pins 11 and 12. By using an LED between these pins (11 and 12), a high-load indication can be realized.

If the potential at pin 6 increases to about 6.2V ( $= V_{T100}$ ), it switches the overload comparator. The result is programmable at pin 9 (operation mode).

#### 3.8.1 Mode Selection

- a)  $\alpha_{\max} (V_9 = 0)$   
 In this mode of operation, pin 13 switches to  $-V_S$  (pin 11) and pin 6 to GND (pin 10) after  $V_6$  has reached the threshold  $V_{T100}$ . A soft-start capacitor is then shorted and the control angle is switched to  $\alpha_{\max}$ . This position is maintained until the supply voltage is switched off. The motor can be started again with the soft-start function when the power is switched on again. As the overload condition switches pin 13 to pin 11, it is possible to use a smaller control angle,  $\alpha_{\max}$ , by connecting a further resistance between pins 13 and 14.
- b) Auto start (pin 9 – open), see [Figure 7-8 on page 12](#)  
 The circuit behaves as described above, with the exception that pin 6 is not connected to GND. If the value of  $V_6$  decreases to 25% of the threshold value ( $V_{T25}$ ), the circuit becomes active again with soft start.
- c)  $I_{\max} (V_9 = V_8)$ , see [Figure 7-10 on page 13](#)  
 When  $V_6$  has reached the maximum overload threshold value (i.e.,  $V_6 = V_{T100}$ ), pin 13 is switched to pin 8 ( $V_{Ref}$ ) through the resistance  $R (= 2k\Omega)$  without the soft-start capacitor discharging at pin 7. With this mode of operation, direct load-current control ( $I_{\max}$ ) is possible.

## 4. Absolute Maximum Ratings

Stresses beyond those listed under “Absolute Maximum Ratings” may cause permanent damage to the device. This is a stress rating only and functional operation of the device at these or any other conditions beyond those indicated in the operational sections of this specification is not implied. Exposure to absolute maximum rating conditions for extended periods may affect device reliability.

Reference point pin 10, unless otherwise specified.

Parameters	Pin	Symbol	Value	Unit
Sink current $t \leq 10\mu\text{s}$	11	$-I_S$	30	mA
	11	$-i_s$	100	mA
Synchronous currents $t \leq 10\mu\text{s}$	15	$\pm I_{\text{syncV}}$	5	mA
	15	$\pm i_{\text{syncV}}$	20	mA
<b>Phase Control</b>				
Control voltage	4, 8	$-V_I$	$0 - V_B$	V
Input current	4	$\pm I_I$	500	$\mu\text{A}$
Charging current	14	$-I_{\text{jtmax}}$	0.5	mA
<b>Soft Start</b>				
Input voltage	7, 8	$-V_I$	$0 - V_B$	V
<b>Pulse Output</b>				
Input voltage	16	$+V_I$	2	V
		$-V_I$	$V_{11}$	V
<b>Reference Voltage Source</b>				
Output current $t \leq 10\mu\text{s}$	8	$I_O$	10	mA
	8	$I_O$	30	mA
<b>Load-current Sensing</b>				
Input currents	1, 2	$\pm I_I$	1	mA
Input voltages	5, 6	$-V_I$	$0 - V_B$	V
Overload output	13	$I_L$	1	mA
High-load output $t \leq 10\mu\text{s}$	12	$I_L$	30	mA
	12	$I_L$	100	mA
Storage temperature range		$T_{\text{stg}}$	$-40$ to $+125$	$^{\circ}\text{C}$
Junction temperature range		$T_j$	125	$^{\circ}\text{C}$
Ambient temperature range		$T_{\text{amb}}$	$-10$ to $+100$	$^{\circ}\text{C}$

## 5. Thermal Resistance

Parameters		Symbol	Value	Unit
Junction ambient	DIP16	$R_{\text{thJA}}$	120	K/W
	SO16 on p.c.	$R_{\text{thJA}}$	180	K/W
	SO16 on ceramic	$R_{\text{thJA}}$	100	K/W

## 6. Electrical Characteristics

$V_S = -13V$ ,  $T_{amb} = 25^\circ C$ , reference point pin 10, unless otherwise specified

Parameters	Test Conditions	Pin	Symbol	Min.	Typ.	Max.	Unit
<b>Supply</b>		11					
Supply-voltage limitation	$-I_S = 3.5mA$ $-I_S = 30mA$		$-V_S$ $-V_S$	14.5 14.6		16.5 16.8	V V
Current requirement	$-V_S = 13.0V$	1, 2, 8 and 15 open	$-I_S$			3.6	mA
<b>Reference Voltage Source</b>		8					
Reference voltage	$I_L = 10\mu A$ $I_L = 2.5mA$		$-V_{Ref}$ $-V_{Ref}$	8.6 8.4	8.9 8.8	9.2 9.1	V V
Temperature coefficient	$I_S = 2.5mA$ $I_S = 10\mu A$		$TC_{V_{Ref}}$ $TC_{V_{Ref}}$		-0.004 +0.006		%/K %/K
<b>Voltage Monitoring</b>		11					
Turn-on threshold			$-V_{Son}$		11.3	12.3	V
<b>Phase Control Synchronization</b>		15					
Input current	Voltage sync.		$\pm I_{syncV}$	0.15		2	mA
Voltage limitation	$\pm I_L = 2mA$		$\pm V_{syncV}$	8.0	8.5	9.0	V
Input current	Current synchronization	16	$\pm I_{syncI}$	3		30	$\mu A$
<b>Reference Ramp, see Figure 7-1 on page 10</b>							
Charging current		14	$-I_\phi$	1		100	$\mu A$
Start voltage		3	$-V_{max}$	1.85	1.95	2.05	V
Temperature coefficient of start voltage		3	$TC_R$		-0.003		%/K
Final voltage		3	$-V_{min}$	$(V_8 \pm 200mV)$			
$R_\phi$ - reference voltage	$I_\phi = 10\mu A$	11, 14	$V_{R\phi}$	0.96	1.02	1.10	V
Temperature coefficient	$I_\phi = 10\mu A$ $I_\phi = 1\mu A$	14	$TC_{VR\phi}$ $TC_{VR\phi}$		0.03 0.06		%/K %/K
Pulse output current	$V_{16} = -1.2V$ , Figure 7-2 on page 10	16	$I_o$	100	125	150	mA
Output pulse width	$V_S = V_{limit}$ $C_3 = 3.3nF$ , see Figure 7-3 on page 10	16	$t_p$		30		$\mu s$
<b>Automatic Retriggering</b>							
Repetition rate	$I_{15} \geq 150\mu A$		$t_{pp}$	3	5	7.5	$t_p$
Threshold voltage		16	$\pm V_I$	20		60	mV
<b>Soft Start, see Figure 7-4 and Figure 7-5 on page 11</b>		7					
Starting current	$V_7 = V_8$		$-I_o$	5	10	15	$\mu A$
Final current	$V_{7-10} = -1V$		$-I_o$	15	25	40	$\mu A$
Discharge current			$+I_o$	0.5			mA
Output current		4	$+I_o$	0.2		2	mA
<b>Mains Voltage Compensation, see Figure 7-6 on page 11</b>		15					
Transfer gain	$I_{15}/I_5$	15/5 (1 and 2 open)	$G_i$	14	17	20	
Output offset current	$V_{(R6)} = V_{15} = V_5 = 0$		$\pm I_o$			2	$\mu A$

## 6. Electrical Characteristics (Continued)

$V_S = -13V$ ,  $T_{amb} = 25^\circ C$ , reference point pin 10, unless otherwise specified

Parameters	Test Conditions	Pin	Symbol	Min.	Typ.	Max.	Unit
<b>Load-current Detection, <math>R_1 = R_2 = 3k\Omega</math>, <math>V_{15} = 0</math>, <math>V_5 = V_6 = V_8</math>, see Figure 7-7 on page 12</b>							
Transfer gain	$I_5/150mV$ , $I_6/150mV$		$G_I$	0.28	0.32	0.37	$\mu A/mV$
Output offset currents		5, 6, 7, 8	$-I_0$	0	3	6	$\mu A$
Reference voltage	$I_1, I_2 = 100\mu A$	1, 2	$-V_{Ref}$	300		400	mV
Shunt voltage amplitude	See Figure 1-2 on page 2		$\pm V_{(R6)}$			250	mV
<b>Load-current Limitation</b> 6, 7, 8							
High load switching	Threshold $V_{T70}$ Figure 7-9 on page 12		$V_{T70}$	4	4.35	4.7	V
Overload switching	Threshold $V_{T100}$ Figure 7-10 on page 13 Figure 7-11 on page 13		$V_{T100}$	5.8	6.2	6.6	V
Restart switching	Threshold $V_{T25}$ Figure 7-8 on page 12		$V_{T25}$	1.25	1.55	1.85	V
Input current	Enquiry mode		$I_i$			1	$\mu A$
Output impedance	Switching mode		$R_0$	2	4	8	$k\Omega$
<b>Programming Input, see Figure 1-2 on page 2</b> 9							
Input voltage - auto-start		9 open	$-V_9$	3.8	4.3	4.7	V
Input current	$V_9 = 0$ ( $a_{max}$ )		$-I_9$	5	10	20	$\mu A$
	$V_9 = V_8$ ( $I_{max}$ )		$I_9$	5	10	20	$\mu A$
<b>High Load Output, <math>V_{T70}</math>, see Figure 7-9 on page 12, <math>I_{12} = -3mA</math></b> 11, 12							
Saturation voltages	$V_{6-8} \leq V_{T70}$		$V_{sat}$	0.5	0.75	1.0	V
	$V_{6-8} \geq V_{T70}$		$V_{lim}$	7.0	7.4	7.8	V
<b>Overload Output, <math>V_{T100}</math>, <math>V_9 = Open</math> or <math>V_9 = V_{10}</math>, see Figure 7-10 on page 13</b>							
Leakage current	$V_{6-8} \leq V_{T25}$ , $V_{13} = (V_{11}+1)V$	13	$I_{lkg}$			0.5	$\mu A$
Saturation voltages	$V_{6-8} \geq V_{T100}$ , $I_{13} = 10\mu A$	11, 12, 13	$V_{sat}$			0.1	V
Output current, maximum load	$V_9 = V_8$ , see Figure 7-10 on page 13	13	$I_{13}$			1	mA
Leakage current	$V_6 \leq V_{T100}$	13	$I_{lkg}$			4	$\mu A$
Output impedance	Open collector, $V_6 \geq V_{T100}$	13	$R_0$	2	4	8	$k\Omega$
Saturation voltage	$V_{6-8} \geq V_{T100}$ , $I_{13} = 10\mu A$	13	$V_{13-8}$		100		mV

## 7. Diagrams

Figure 7-1. Ramp Control

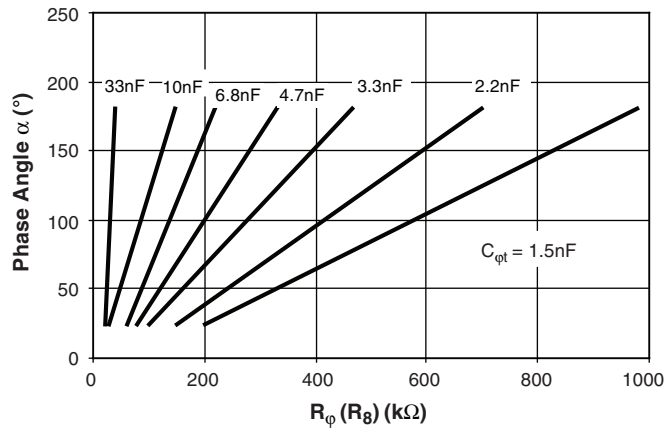

Figure 7-2. Pulse Output

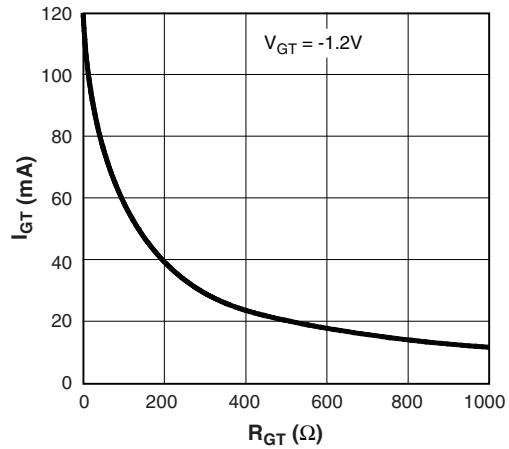

Figure 7-3. Output Pulse Width

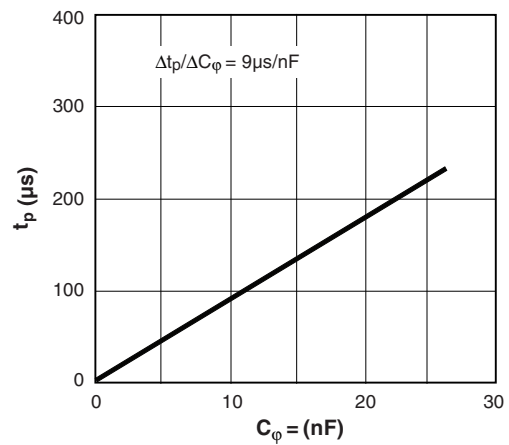

Figure 7-4. Soft-start Charge Current

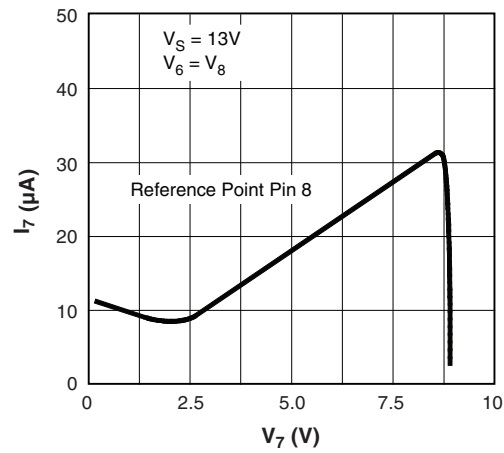

Figure 7-5. Soft-start Characteristic

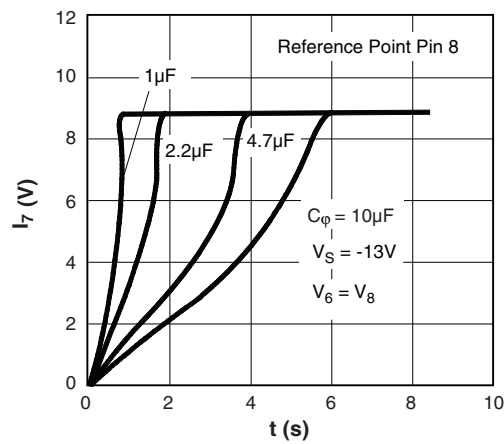
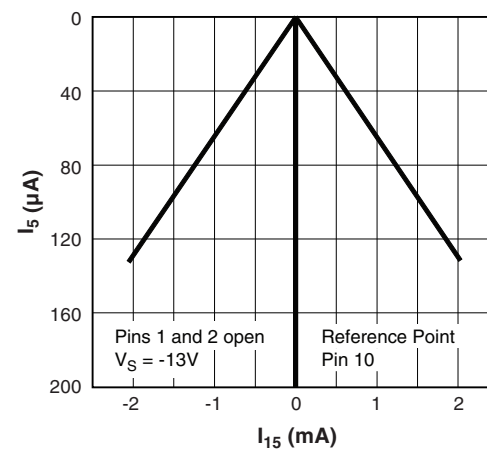
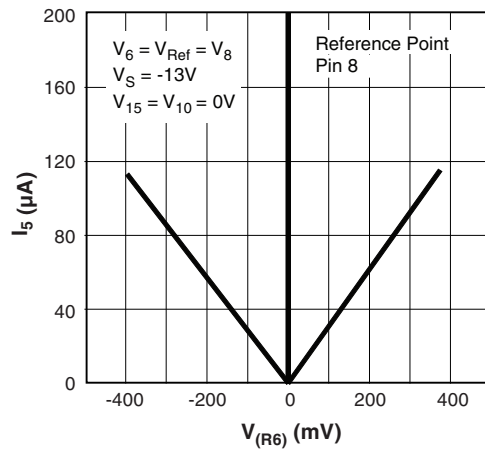

Figure 7-6. Mains Voltage Compensation



**Figure 7-7. Load-current Detection**



**Figure 7-8. Restart Switching Auto Start Mode**

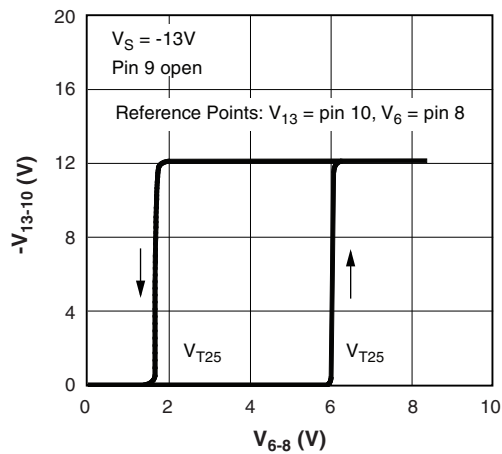

**Figure 7-9. High Load Switching (70%)**

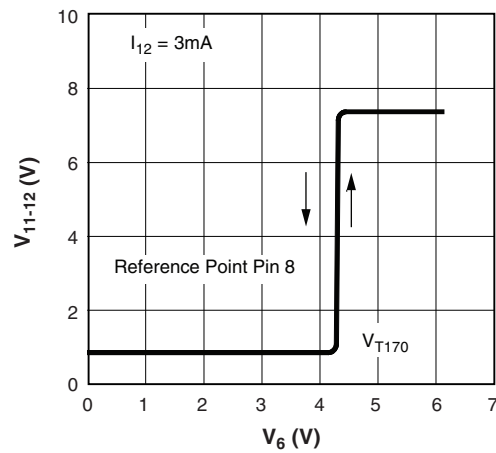

Figure 7-10. Overload Switching

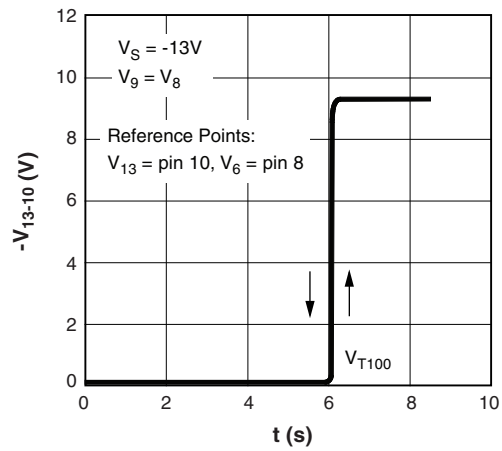

Figure 7-11. Load Limitation

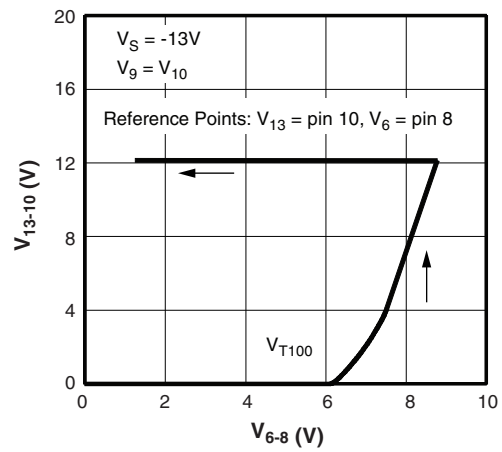
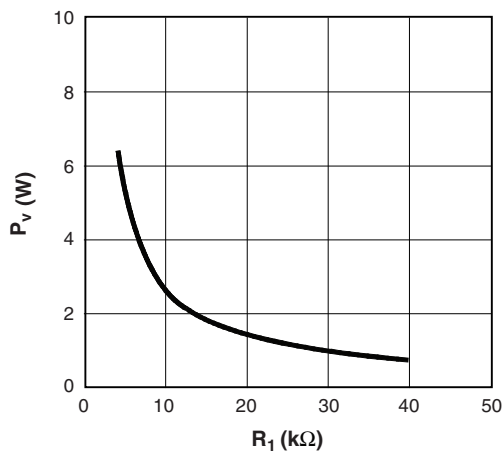
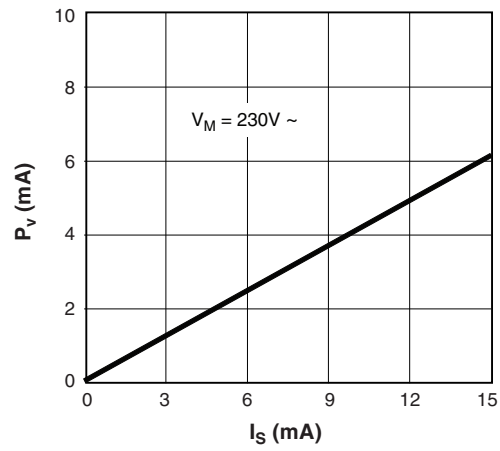

Figure 7-12. Power Dissipation of  $R_1$



**Figure 7-13.** Power Dissipation of  $R_1$  According to Current Consumption



**Figure 7-14.** Maximum Resistance of  $R_1$

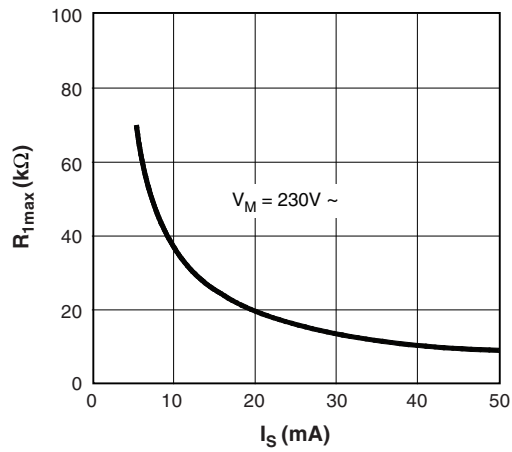

**Figure 7-15. Application Circuit**

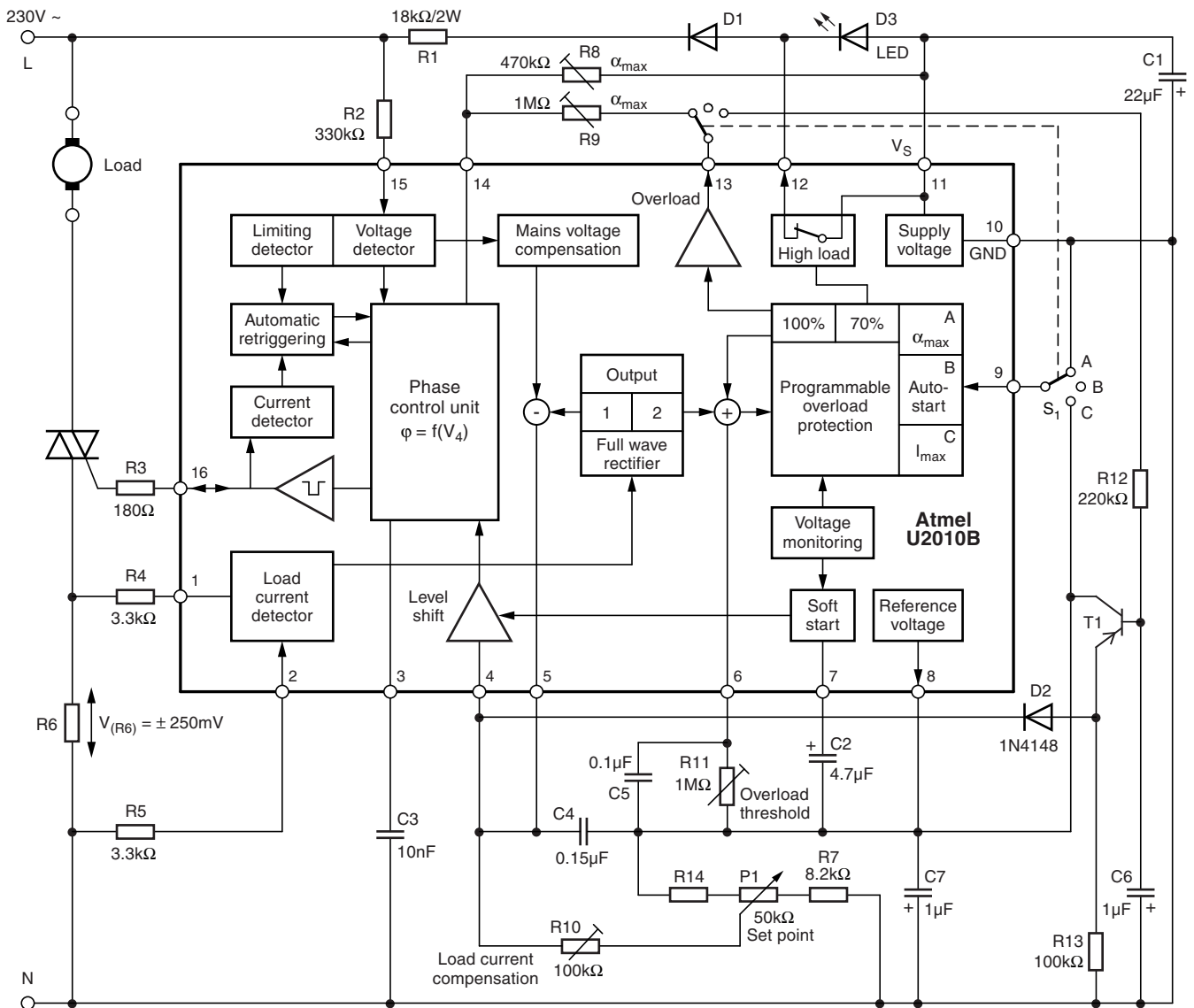

## 8. Ordering Information

Extended Type Number	Package	Remarks
U2010B-MY	DIP16	Tube, Pb-free
U2010B-MFPY	SO16	Tube, Pb-free
U2010B-MFPG3Y	SO16	Taped and reeled, Pb-free

## 9. Package Information

Package DIP16  
Dimensions in mm

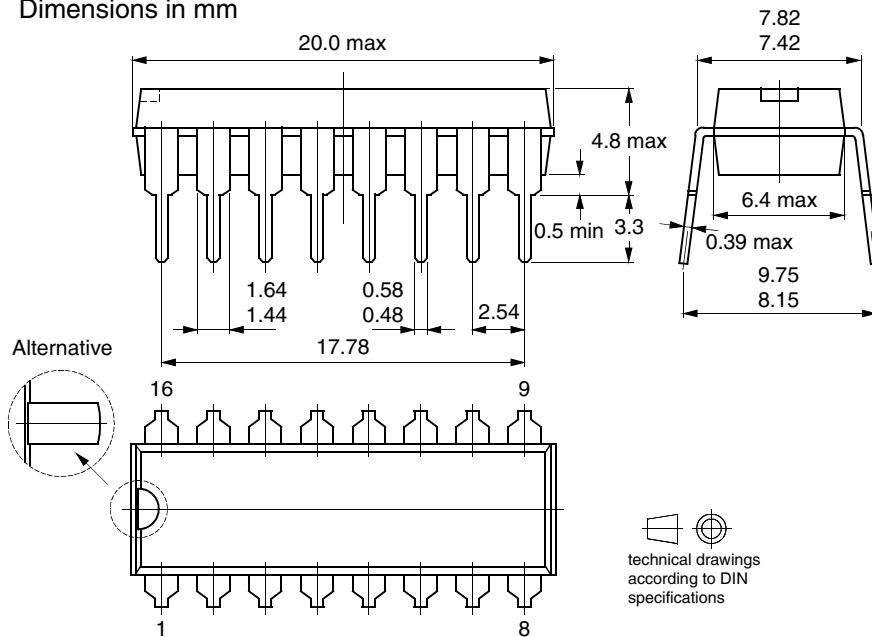

Package: SO 16

Dimensions in mm

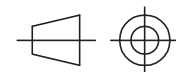
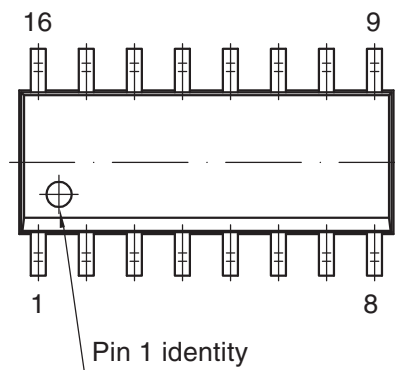

technical drawings  
according to DIN  
specifications

Drawing-No.: 6.541-5031.02-4

Issue: 1; 15.08.06

## 10. Revision History

Please note that the following page numbers referred to in this section refer to the specific revision mentioned, not to this document.

Revision No.	History
4766D-INDCO-03/11	<ul style="list-style-type: none"> <li>Put datasheet in a new template</li> <li>Page 7: Abs.Max.Ratings table: Change in row Synchronous currents</li> <li>Page 8: El.Characteristics: Change in heading</li> </ul>
4766C-INDCO-04/10	<ul style="list-style-type: none"> <li>Put datasheet in the newest template</li> <li>Pb-free logo on page 1 deleted</li> <li>Figure 2-1 "Pinning DIP16/SO16" on page 3 changed</li> </ul>
4766B-INDCO-08/05	<ul style="list-style-type: none"> <li>Put datasheet in the newest template</li> <li>Pb-free logo on page 1 added</li> <li>Section 8 "Ordering Information" on page 16 changed</li> </ul>



***Atmel Corporation***

2325 Orchard Parkway  
San Jose, CA 95131  
USA

**Tel:** (+1)(408) 441-0311

**Fax:** (+1)(408) 487-2600

***Atmel Asia Limited***

Unit 01-5 & 16, 19/F  
BEA Tower, Millennium City 5  
418 Kwun Tong Road  
Kwun Tong, Kowloon  
HONG KONG

**Tel:** (+852) 2245-6100

**Fax:** (+852) 2722-1369

***Atmel Munich GmbH***

Business Campus  
Parking 4  
D-85748 Garching b. Munich  
GERMANY

**Tel:** (+49) 89-31970-0

**Fax:** (+49) 89-3194621

***Atmel Japan***

9F, Tonetsu Shinkawa Bldg.  
1-24-8 Shinkawa  
Chuo-ku, Tokyo 104-0033  
JAPAN

**Tel:** (+81) (3) 3523-3551

**Fax:** (+81) (3) 3523-7581

© 2011 Atmel Corporation. All rights reserved. / Rev.: 4766D-INDCO-03/11

Atmel®, Atmel logo and combinations thereof, and others are registered trademarks or trademarks of Atmel Corporation or its subsidiaries. Other terms and product names may be trademarks of others.

Disclaimer: The information in this document is provided in connection with Atmel products. No license, express or implied, by estoppel or otherwise, to any intellectual property right is granted by this document or in connection with the sale of Atmel products. EXCEPT AS SET FORTH IN THE ATMEL TERMS AND CONDITIONS OF SALES LOCATED ON THE ATMEL WEBSITE, ATMEL ASSUMES NO LIABILITY WHATSOEVER AND DISCLAIMS ANY EXPRESS, IMPLIED OR STATUTORY WARRANTY RELATING TO ITS PRODUCTS INCLUDING, BUT NOT LIMITED TO, THE IMPLIED WARRANTY OF MERCHANTABILITY, FITNESS FOR A PARTICULAR PURPOSE, OR NON-INFRINGEMENT. IN NO EVENT SHALL ATMEL BE LIABLE FOR ANY DIRECT, INDIRECT, CONSEQUENTIAL, PUNITIVE, SPECIAL OR INCIDENTAL DAMAGES (INCLUDING, WITHOUT LIMITATION, DAMAGES FOR LOSS AND PROFITS, BUSINESS INTERRUPTION, OR LOSS OF INFORMATION) ARISING OUT OF THE USE OR INABILITY TO USE THIS DOCUMENT, EVEN IF ATMEL HAS BEEN ADVISED OF THE POSSIBILITY OF SUCH DAMAGES. Atmel makes no representations or warranties with respect to the accuracy or completeness of the contents of this document and reserves the right to make changes to specifications and products descriptions at any time without notice. Atmel does not make any commitment to update the information contained herein. Unless specifically provided otherwise, Atmel products are not suitable for, and shall not be used in, automotive applications. Atmel products are not intended, authorized, or warranted for use as components in applications intended to support or sustain life.