

Features

- Very High Transmitting Frequency Accuracy Compared to SAW Solutions (Enables Receivers at Lower Bandwidth than with SAW Resonators)
- Lower Cost than the Usual Discrete Solutions Using SAW and Transistors
- Supply Voltage 2.0V to 5.5V in the Temperature Range -20°C to $+70^{\circ}\text{C}$
Supply Voltage 2.2 V to 5.5 V in the Temperature Range -40°C to $+85^{\circ}\text{C}$
- XTO Output for Clocking the Microcontroller, Thereby Together with the ATAR090 or ATAR890 Results in the Optimum System Cost-effectiveness
- One-chip Solution with Minimum External Circuitry
- Very Small SSO16 Package, Pitch 0.635, 150 mil
- “Single-ended Open-collector” Output (Same Antennas as in Discrete Solutions Can Be Used, Simpler Adaptation of Magnetic Loop Antennas)
- Very Large FSK Frequency Deviation Achievable by ± 100 ppm Pulling of the Reference Crystal
- Enables Receivers at Lower Bandwidth than with SAW Resonators
- ESD Protection According to MIL-STD.883 (4 KV HBM) Except Pins XTO1/ 2, ANT and LF



Electrostatic sensitive device.
Observe precautions for handling.



1. Description

The U2741B is a PLL transmitter IC which has been especially developed for the demands of RF low-cost data transmission systems at data rates up to 20 kBaud.

The transmitting frequency range is 300 MHz to 450 MHz. The device can be used in both FSK and ASK systems.



UHF ASK/FSK Transmitter

U2741B



Figure 1-1. System Block Diagram

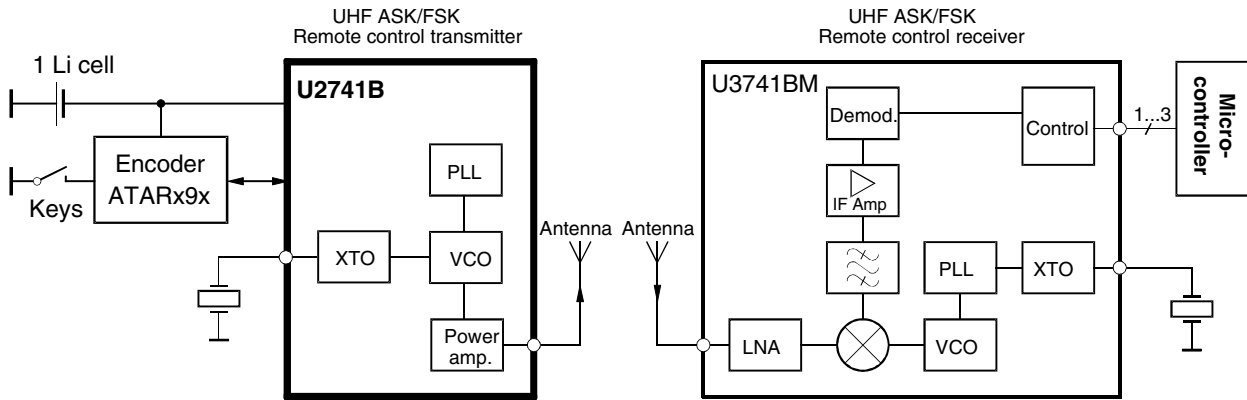
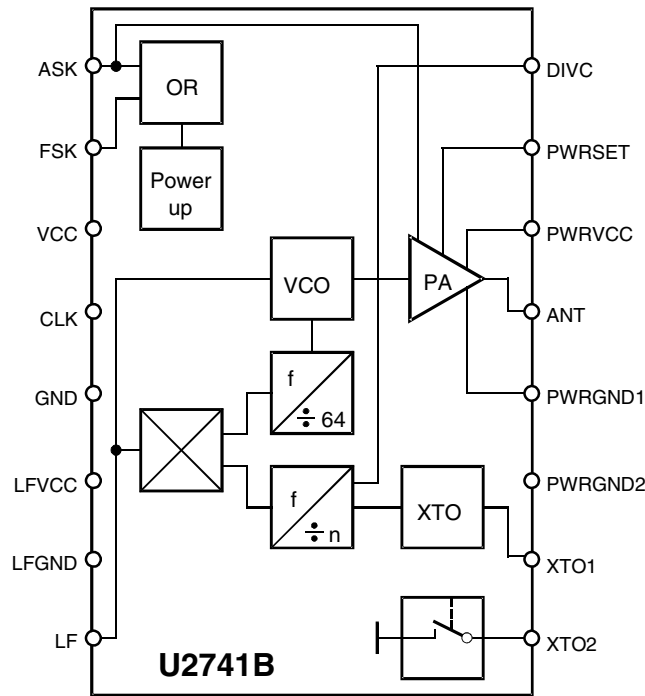

Figure 1-2. Block Diagram



2. Pin Configuration

Figure 2-1. Pinning SSO16

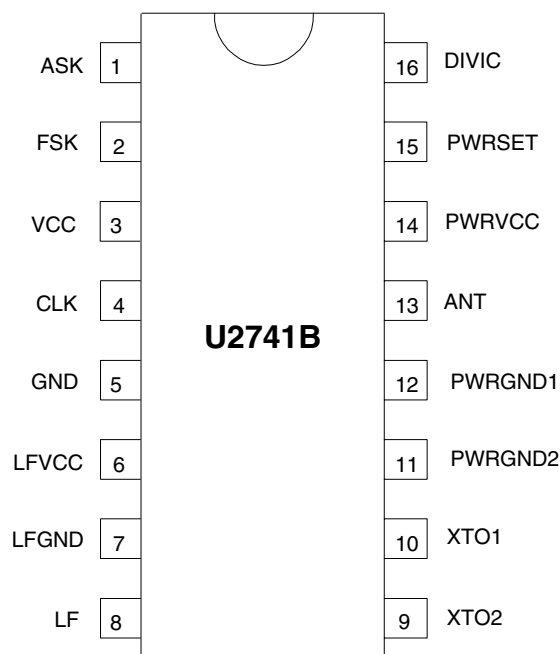

Table 2-1. Pin Description

Pin	Symbol	Function
1	ASK	Modulation input ASK
2	FSK	Modulation input FSK
3	VCC	Supply voltage
4	CLK	Clock output
5	GND	Ground
6	LFVCC	Supply voltage VCO
7	LFGND	VCO ground
8	LF	Circuit PLL loop
9	XTO2	FM modulation output
10	XTO1	Connection for crystal
11	PWRGND2	Power GND2
12	PWRGND1	Power GND1
13	ANT	RF output
14	PWRVCC	Supply voltage power amplifier
15	PWRSET	Applied to VCC
16	DIVIC	Pitch factor setting for crystal L: high crystal frequency H: low crystal frequency

3. General Description

The fully integrated VCO and the “single-ended open-collector” output allow particularly simple, low-cost RF miniature transmitters to be assembled. The single-ended output enables a considerably simplified adaptation of both a magnetic loop antenna of any form or a $\lambda/4$ antenna. This is because the load impedance must not be balanced as would be the case with a differential output.

The XTO's frequency can be selected at either 13.56 MHz (USA 9.844 MHz) or 6.78 MHz (USA 4.9219 MHz). Thus, it is possible to use not only exceptionally small SMD crystals at 13.56 MHz but also very low-cost 6.78 MHz crystals in a wired metal package (e.g., in the HC49S housing). The frequency is selected by connecting pin 16 (DIVC) to either GND or V_S .

At high frequencies, crystals have a very fast start-up time (< 1.5 ms at 13.56 MHz, < 3 ms at 6.78 MHz), whereby a wait time of 5 to 10 ms is required until the transmitter IC is locked. This means that the processor does not need to poll a lock detect output.

4. Functional Description

The IC can be switched on at both the FSK and the ASK input. The IC's ChipSelect is performed by the logical OR operation of ASK and FSK input. In the case of $V_{FSK}, V_{ASK} \leq 0.3V$, the power-down supply current is $I_{S_{off}} < 0.35 \mu A$. The ASK input activates the power amplifier and the PLL. The FSK input only activates the PLL and, if capacitor C_3 is installed, pulls the crystal to the lower frequency, whereby the transmitter is FSK modulated. After switching on at FSK, the VCO locks onto the 32 or 64 times higher frequency of the crystal oscillator.

4.1 FSK Transmission

The U2741B is switched on by $V_{FSK} = V_S$. 5 ms later, V_S is applied to V_{ASK} . The output can then be modulated by means of pin FSK. This is done by connecting capacitor C_3 in parallel to the load capacitor C_4 .

4.2 ASK Transmission

The U2741B is activated by $V_{FSK} = V_S$. V_{ASK} remains 0V for 5 ms, then the output power can be modulated by means of pin ASK. In this case, V_{FSK} remains = V_S during the message, the capacitor C_3 is not mounted.

4.3 Take-over of the Clock Pulse in the Microcontroller

The clock of the crystal oscillator can be used for clocking the microcontroller. The ATAR090 and ATAR890 have the special feature of starting with an integrated RC oscillator to switch on the U2741B with $V_{FSK} = V_S$. 5 ms later, the 3.39-MHz clock frequency is present, so that the message can be sent with crystal accuracy.

5. Application Circuit

The following component values are recommendations for a typical application. C_5 , C_6 , and C_7 are block capacitors. The values of these capacitors depend on the board layout. $C_5 = 1$ nF, $C_6 = 1$ nF, and $C_7 = 22$ nF are typically used here. For C_5 , the impedance between $f = 100$ MHz and $f = 1$ GHz should be as low as possible.

C_3 is not needed in ASK transmitter applications. In the case of FSK, C_3 is selected in such a way that the desired transmission frequency deviation is achieved (typical ± 30 kHz). The capacitance here depends upon the crystal's load capacity (C_4) recommended by the manufacturer of the crystal. $C_2 = 3.9$ nF, $C_1 = 15$ nF, and $R_4 = 220\Omega$

C_{Loop1} and C_{Loop2} are selected so that the antenna oscillates in resonance and the adaptation to the appropriate impedance transformation is possible.

L_{Feed} is an inductor for the antenna's DC current supply. A typical value is $L_{Feed} = 220$ nH. L_{Feed} can be either printed on the PC board or be a discrete component.

5.1 Output Power Measurement

The output network [as shown in [Figure 5-1](#)] can be used for output power evaluation, the exact values of L_{10} and C_{10} depend on the layout.

L_{10} and C_{10} form the transformation network to adopt the output impedance of the IC to 50Ω . [Table 5-1](#) shows the values for an output power of 2 mW and an $R_{PWRSET} = 1.2$ k Ω

Table 5-1. Transformation Network

f/MHz	C10/pF	L10/nH	Z_{Load_opt}/Ω
315	2.7	56	$260 + j330$
433.92	1.8	33	$185 + j268$

Figure 5-1. Measurement Output Network

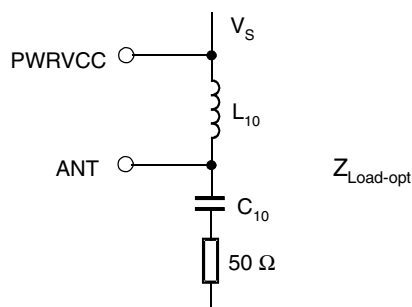
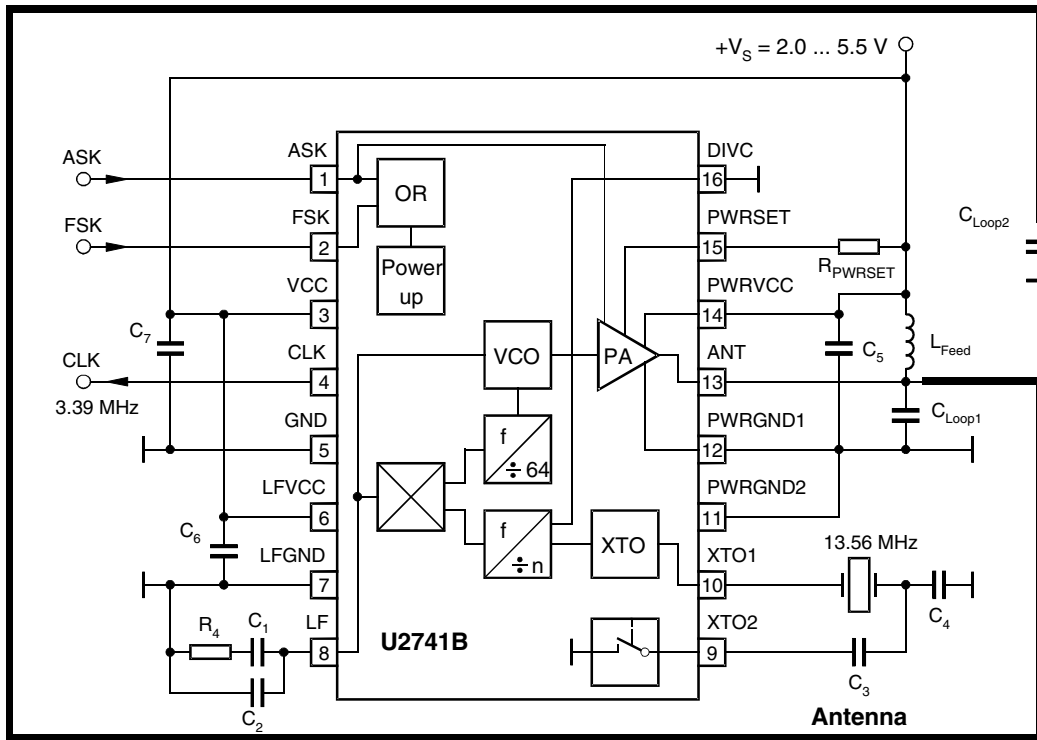

Figure 5-2. Application Circuit



6. Absolute Maximum Ratings

Stresses beyond those listed under “Absolute Maximum Ratings” may cause permanent damage to the device. This is a stress rating only and functional operation of the device at these or any other conditions beyond those indicated in the operational sections of this specification is not implied. Exposure to absolute maximum rating conditions for extended periods may affect device reliability.

Parameters	Symbol	Min.	Max.	Unit
Supply voltage	V_S		6	V
Power dissipation	P_{tot}		250	mW
Junction temperature	T_j		150	°C
Storage temperature	T_{stg}	-55	125	°C
Ambient temperature	T_{amb}	-40	105	°C

7. Thermal Resistance

Parameters	Symbol	Value	Unit
Junction ambient	R_{thJA}	180	K/W

8. Electrical Characteristics

All parameters are referred to GND (pin 5). The possible operating ranges refer to different circuit conditions:

$V_S = 2.0V$ to $5.5V$ at $T_{amb} = -20^\circ C$ to $+70^\circ C$, $V_S = 2.2V$ to $5.5V$ at $T_{amb} = -40^\circ C$ to $+85^\circ C$ (typically $25^\circ C$, $3V$)

Parameters	Test Conditions	Symbol	Min.	Typ.	Max.	Unit
Supply current (power down)	$V_{ASK}, V_{FSK} \leq 0.3V, V_S < 3.6V$	I_{Soff}			0.35	μA
Supply current (power up, output OFF)	$V_{ASK} = GND, V_{FSK} = V_S, V_S = 3V$	I_{Son}		4.7	6.2	mA
Supply current (power up, output ON)	$V_{ASK} = V_S, V_S = 3V, R_{PWRSET} = 1.2 k\Omega$	$I_{Stransmit}$		10	12.5	mA
Output power	$V_S = 3V, T_{amb} = 25^\circ C, f = 433.92 MHz$ $R_{PWRSET} = 1.2 k\Omega$ $R_{PWRSET} = 1.8 k\Omega$	P_{Ref}	1.5	3	5	dBm
		P_{Ref}	-0.5	1	3	dBm
Output power variation for the full temperature range	$T_{amb} = -40^\circ C$ to $+85^\circ C, f = 433.92 MHz,$ $V_S = 3.0V$ $V_S = 2.4V$	ΔP_{Ref}			-1.5	dB
		ΔP_{Ref}			-4.0	dB
Output power variation for $f = 315 MHz$ compared to $f = 433.92 MHz$	$T_{amb} = -20^\circ C$ to $+85^\circ C, f = 433.92 MHz,$ $V_S = 2.0V$ $P_{out} = P_{Ref} + \Delta P_{Ref}$	ΔP_{Ref}		1.5		dB
		ΔP_{Ref}				
Maximum peak output antenna voltage	at $P_{out} = 2.0 mW$, the load impedance must be selected to meet the V_{out} maximum requirement the supply current is not dependent on the load impedance tolerance	V_{outmax}		$V_S - 0.7V$		$V_{(peak)}$
Spurious emission	at $T_{amb} = 25^\circ C$ $f_o \pm (n \times f_{PC})$ where $f_{PC} = 6.78 MHz$ Load capacitance at CLK $\leq 3 pF$ $f = 230 MHz$ to $470 MHz$ $f < 230 MHz, f > 470 MHz$	Em			-40	dBc
		Em			-58	dBc

8. Electrical Characteristics (Continued)

All parameters are referred to GND (pin 5). The possible operating ranges refer to different circuit conditions:
 $V_S = 2.0V$ to $5.5V$ at $T_{amb} = -20^{\circ}C$ to $+70^{\circ}C$, $V_S = 2.2V$ to $5.5V$ at $T_{amb} = -40^{\circ}C$ to $+85^{\circ}C$ (typically $25^{\circ}C$, $3V$)

Parameters	Test Conditions	Symbol	Min.	Typ.	Max.	Unit
Oscillator frequency XTO	M-version: at $T_{amb} = 25^{\circ}C$ N-version: full temperature range (monitoring) Crystal frequency = 13.56 MHz	f_{XTO}	13.56 – 30 ppm	13.56	13.56 + 30 ppm	MHz
	Crystal frequency = 6.78 MHz Load capacity of the crystal must be selected accordingly	f_{XTO}	6.78 – 30 ppm	6.78	6.78 + 30 ppm	MHz
Loop bandwidth	For best LO noise Loop filter components: $C_2 = 3.9$ nF, $C_1 = 15$ nF, $R_4 = 220\Omega$	B_{Loop}		100		kHz
Phase noise PLL	Referring to the phase comparator $f_{PC} = 6.78$ MHz	PN_{PLL}		-111	-105	dBc/Hz
Phase noise VCO	at 1 MHz at 36 MHz	PN_{VCO} PN_{VCO}		-91 -123	-87 -119	dBc/Hz
Frequency range of the VCO		f_{VCO}	300		450	MHz
Clock output (CMOS microcontroller compatible)		Clk_{out}		$f_{out}/128$		MHz
Load capacitance at CLK		C_{CLK}			10	pF
Series resonance R of the crystal	$f_{XTO} = 13.56$ MHz $f_{XTO} = 9.84$ MHz $f_{XTO} = 6.78$ MHz $f_{XTO} = 4.90$ MHz	R_s R_s R_s R_s			80 100 150 225	Ω
FSK modulation frequency rate	Duty cycle of the modulation signal = 50%	f_{modFSK}	0		20	kHz
ASK modulation frequency rate	Duty cycle of the modulation signal = 50%	f_{modASK}	0		20	kHz
CLK output - Output current Low - Output current Low - Output current High - Output current High	$V_{CLK} = 0.2 \times V_S$ $V_{CLK} = 0.3 \times V_S$ $V_{CLK} = 0.8 \times V_S$ $V_{CLK} = 0.7 \times V_S$	I_{ol} I_{ol} I_{oh} I_{oh}	150 200 -150 -200		+100	μA μA μA μA
ASK input - Low level input voltage - High level input voltage - Input current High		V_{ASKl} V_{ASKh} I_{ASKh}	1.7		0.3 140	V V μA
FSK input - Low level input voltage - High level input voltage - Input current High		V_{FSKl} V_{FSKh} I_{FSKh}	1.7		0.3 140	V V μA

9. Ordering Information

Extended Type Number	Package	Remarks
U2741B-NFBY	SSO16	Tube, optimized power-supply rejection, value of C ₄ differs from M-version, enhanced XTO stability, Pb-free
U2741B-NFBG3Y	SSO16	Taped and reeled, see above, Pb-free

10. Package Information

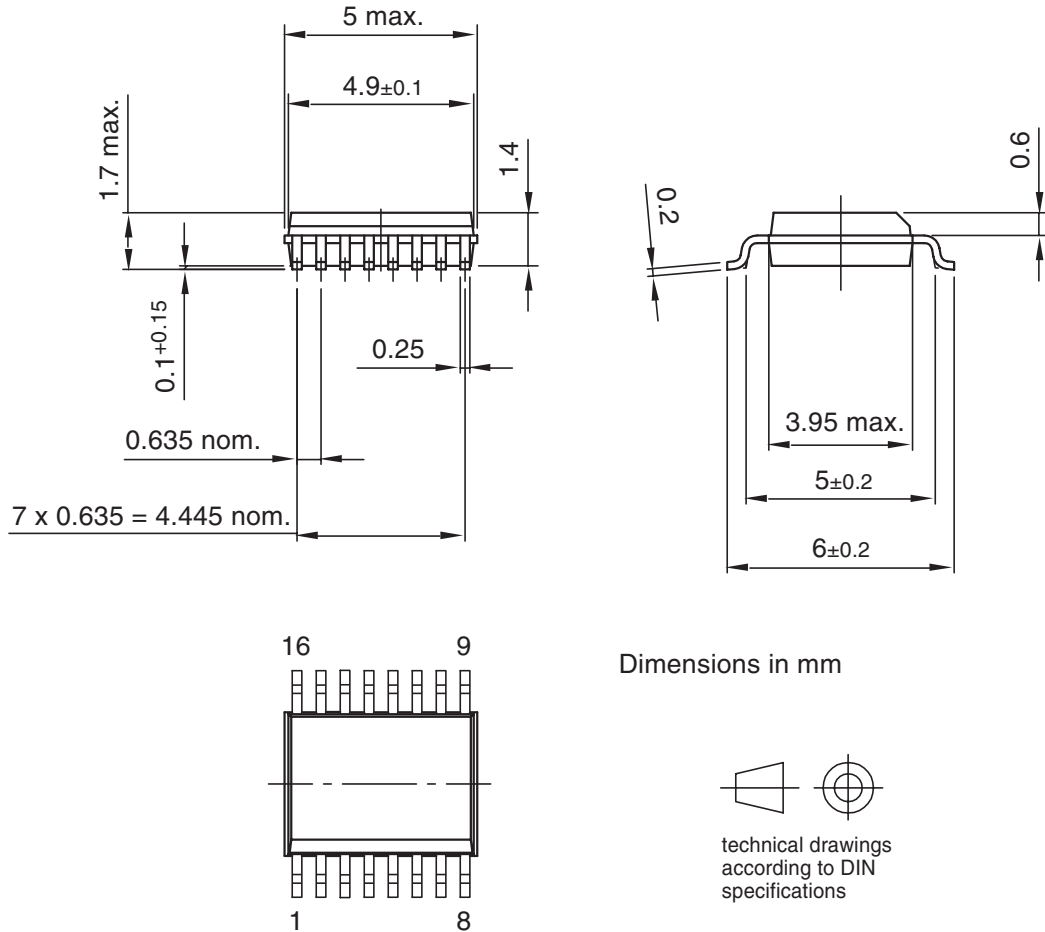

Drawing-No.: 6.543-5060.01-4
 Issue: 2; 05.02.99

Drawing refers to following types: SSO16
 Package acc. JEDEC MO 137 AB

11. Revision History

Please note that the following page numbers referred to in this section refer to the specific revision mentioned, not to this document.

Revision No.	History
4733B-RKE-09/05	<ul style="list-style-type: none">• Put datasheet in a new template• Pb-free Logo on page 1 added• Ordering Information on page 9 changed



Atmel Corporation

2325 Orchard Parkway
San Jose, CA 95131, USA
Tel: 1(408) 441-0311
Fax: 1(408) 487-2600

Regional Headquarters

Europe

Atmel Sarl
Route des Arsenaux 41
Case Postale 80
CH-1705 Fribourg
Switzerland
Tel: (41) 26-426-5555
Fax: (41) 26-426-5500

Asia

Room 1219
Chinachem Golden Plaza
77 Mody Road Tsimshatsui
East Kowloon
Hong Kong
Tel: (852) 2721-9778
Fax: (852) 2722-1369

Japan

9F, Tonetsu Shinkawa Bldg.
1-24-8 Shinkawa
Chuo-ku, Tokyo 104-0033
Japan
Tel: (81) 3-3523-3551
Fax: (81) 3-3523-7581

Atmel Operations

Memory

2325 Orchard Parkway
San Jose, CA 95131, USA
Tel: 1(408) 441-0311
Fax: 1(408) 436-4314

Microcontrollers

2325 Orchard Parkway
San Jose, CA 95131, USA
Tel: 1(408) 441-0311
Fax: 1(408) 436-4314

La Chantrerie
BP 70602
44306 Nantes Cedex 3, France
Tel: (33) 2-40-18-18-18
Fax: (33) 2-40-18-19-60

ASIC/ASSP/Smart Cards

Zone Industrielle
13106 Rousset Cedex, France
Tel: (33) 4-42-53-60-00
Fax: (33) 4-42-53-60-01

1150 East Cheyenne Mtn. Blvd.
Colorado Springs, CO 80906, USA
Tel: 1(719) 576-3300
Fax: 1(719) 540-1759

Scottish Enterprise Technology Park
Maxwell Building
East Kilbride G75 0QR, Scotland
Tel: (44) 1355-803-000
Fax: (44) 1355-242-743

RF/Automotive

Theresienstrasse 2
Postfach 3535
74025 Heilbronn, Germany
Tel: (49) 71-31-67-0
Fax: (49) 71-31-67-2340

1150 East Cheyenne Mtn. Blvd.
Colorado Springs, CO 80906, USA
Tel: 1(719) 576-3300
Fax: 1(719) 540-1759

Biometrics/Imaging/Hi-Rel MPU/ High Speed Converters/RF Datacom

Avenue de Rochepleine
BP 123
38521 Saint-Egreve Cedex, France
Tel: (33) 4-76-58-30-00
Fax: (33) 4-76-58-34-80

Literature Requests

www.atmel.com/literature

Disclaimer: The information in this document is provided in connection with Atmel products. No license, express or implied, by estoppel or otherwise, to any intellectual property right is granted by this document or in connection with the sale of Atmel products. **EXCEPT AS SET FORTH IN ATMEL'S TERMS AND CONDITIONS OF SALE LOCATED ON ATMEL'S WEB SITE, ATMEL ASSUMES NO LIABILITY WHATSOEVER AND DISCLAIMS ANY EXPRESS, IMPLIED OR STATUTORY WARRANTY RELATING TO ITS PRODUCTS INCLUDING, BUT NOT LIMITED TO, THE IMPLIED WARRANTY OF MERCHANTABILITY, FITNESS FOR A PARTICULAR PURPOSE, OR NON-INFRINGEMENT. IN NO EVENT SHALL ATMEL BE LIABLE FOR ANY DIRECT, INDIRECT, CONSEQUENTIAL, PUNITIVE, SPECIAL OR INCIDENTAL DAMAGES (INCLUDING, WITHOUT LIMITATION, DAMAGES FOR LOSS OF PROFITS, BUSINESS INTERRUPTION, OR LOSS OF INFORMATION) ARISING OUT OF THE USE OR INABILITY TO USE THIS DOCUMENT, EVEN IF ATMEL HAS BEEN ADVISED OF THE POSSIBILITY OF SUCH DAMAGES.** Atmel makes no representations or warranties with respect to the accuracy or completeness of the contents of this document and reserves the right to make changes to specifications and product descriptions at any time without notice. Atmel does not make any commitment to update the information contained herein. Unless specifically provided otherwise, Atmel products are not suitable for, and shall not be used in, automotive applications. Atmel's products are not intended, authorized, or warranted for use as components in applications intended to support or sustain life.

© Atmel Corporation 2005. All rights reserved. Atmel®, logo and combinations thereof, Everywhere You Are® and others, are registered trademarks or trademarks of Atmel Corporation or its subsidiaries. Other terms and product names may be trademarks of others.



Printed on recycled paper.