

Features

- Temperature and Voltage Compensated Frequency
- Warning Indication of Lamp Failure by Means of Frequency Doubling
- Minimum Lamp Load for Flasher Operation $\geq 10\text{W}$
- Relay Output with High Current Carrying Capacity and Low Saturation Voltage
- Low Susceptibility to EMI



Flasher, 30 m Ω
Shunt, Pilot
Lamp to GND or
 V_{Batt}

1. Description

The integrated circuit U2043B is used in relay-controlled automotive flashers where a high EMC level is required. A lamp outage is indicated by frequency doubling during hazard mode as well as direction mode. The pilot lamp can be connected either to V_{Batt} or GND.

Figure 1-1. Block Diagram

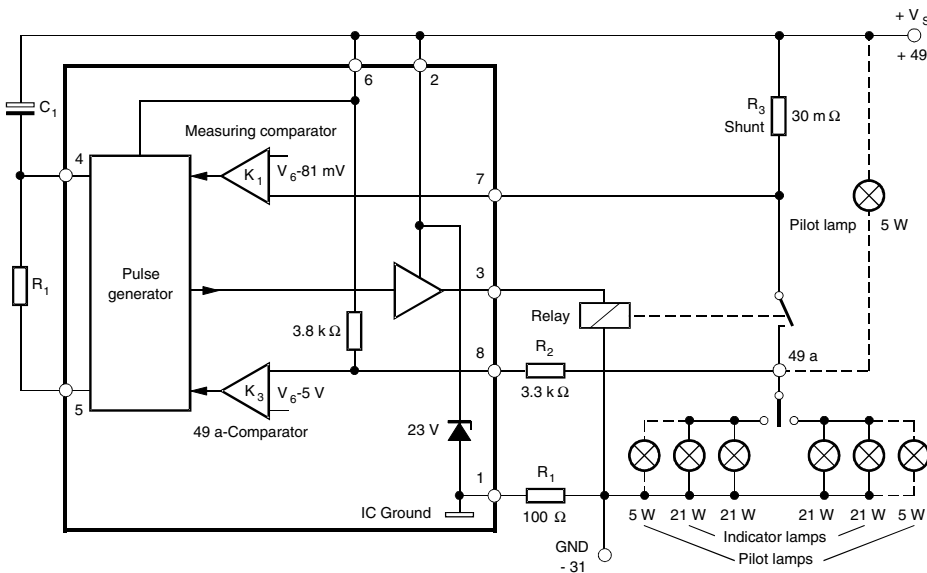

2. Pin Configuration

Figure 2-1. Pinning DIP8/SO8

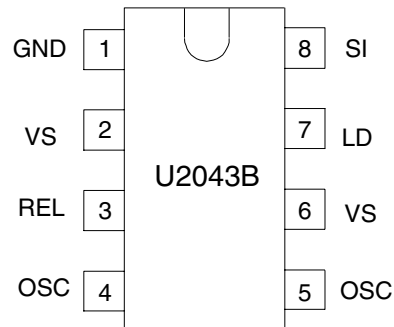

Table 2-1. Pin Description

| Pin | Symbol | Function |
|-----|--------|------------------------|
| 1 | GND | IC ground |
| 2 | VS | Supply voltage V_S |
| 3 | REL | Relay driver |
| 4 | OSC | C_1 Oscillator |
| 5 | OSC | R_1 Oscillator |
| 6 | VS | Supply voltage V_S |
| 7 | LD | Lamp failure detection |
| 8 | SI | Start input (49a) |

3. Functional Description

3.1 GND (Pin 1)

The integrated circuit is protected against damage via resistor R_4 to ground (–31) in the case of battery reversal. An integrated protection circuit together with external resistances R_2 and R_4 limits the current pulses in the IC.

3.2 Supply Voltage, V_S Power (Pin 2)

The arrangement of the supply connections to pin 2 must be so as to ensure that, on the connection printed circuit board (PCB), the resistance of V_S to pin 6 is lower than that to pin 2.

3.3 Relay Control Output (Driver, Pin 3)

The relay control output is a high-side driver with a low saturation voltage and capable of driving a typical automotive relay with a minimum coil resistance of 60Ω .

3.4 Oscillator (Pin 4 and 5)

Flashing frequency, f_1 , is determined by the R_1C_1 components as follows (see [Figure 1-1 on page 1](#)):

$$f_1 = \frac{1}{R_1 \times C_1 \times 1.5} \text{ Hz}$$

where $C_1 \leq 47 \mu\text{F}$
 $R_1 = 6.8 \text{ k}\Omega$ to $510 \text{ k}\Omega$

In the case of a lamp outage (see pin 7) the oscillator frequency is switched to the lamp outage frequency f_2 with $f_2 \approx 2.2 \times f_1$.

| | |
|-------------------------------------|--------------------|
| Duty cycle in normal flashing mode: | 50% |
| Duty cycle in lamp outage mode: | 40% (bright phase) |

3.5 Supply Voltage, Sense (Pin 6)

For accurate monitoring via the shunt resistor, a minimized layer resistance from point V_S /shunt to pin 6 is recommended.

3.6 Lamp Outage Detection (Pin 7)

The lamp current is monitored via an external shunt resistor R_3 and an internal comparator K1 with its reference voltage of typically 81 mV ($V_S = 12V$). The outage of one lamp out of two lamps is detected according to the following calculation:

$$\text{Nominal current of 1 lamp: } 21W/(V_S = 12V): \quad I_{\text{lamp}} = 1.75A$$

$$\text{Nominal current of 2 lamps: } 2 \times 21W/(V_S = 12V): \quad I_{\text{lamp}} = 3.5A$$

We recommend setting the detection threshold in the middle of the current range:

$$I_{\text{outage}} \approx 2.7A$$

Thus, the shunt resistor is calculated as:

$$R_3 = V_T (K1)/I_{\text{outage}}$$

$$R_3 = 81 \text{ mV}/2.7 \text{ A} = 30 \text{ m}\Omega$$

Comparator K1's reference voltage is matched to the characteristics of filament lamps (see section "Control Signal Threshold").

The combination of the shunt resistor and the resistance of the wire harness prevents pin 7 from a too high voltage in the case of shorted lamps.

3.7 Start Input (Pin 8)

Start condition for flashing:

The voltage at pin 8 has to be less than $V_S - 5V$ (flasher switch closed).

Humidity and dirt may decrease the resistance between 49a and GND. If this leakage resistance is $> 5 \text{ k}\Omega$ the IC is still kept in its off-condition. In this case the voltage at pin 8 is greater than $V_S - 5V$.

During the bright phase the voltage at pin 8 is above the K2 threshold, during the dark phase it is below the K3 threshold. For proper start conditions a minimum lamp wattage of 10W is required.

4. Absolute Maximum Ratings

Stresses beyond those listed under “Absolute Maximum Ratings” may cause permanent damage to the device. This is a stress rating only and functional operation of the device at these or any other conditions beyond those indicated in the operational sections of this specification is not implied. Exposure to absolute maximum rating conditions for extended periods may affect device reliability.

Reference point: pin 1

| Parameters | Symbol | Value | Unit |
|--|-----------|-------------|------------------|
| Supply voltage, pins 2 and pin 6 | V_S | 16.5 | V |
| Surge forward current | | | |
| $t_p = 0.1$ ms | I_{FSM} | 1.5 | A |
| $t_p = 2$ ms | I_{FSM} | 1.0 | A |
| $t_p = 2$ ms | I_{FSM} | 50 | mA |
| Output current, pin 3 | I_O | 0.3 | A |
| Power Dissipation | | | |
| $T_{amb} = 95^\circ\text{C}$, DIP8 SO8 | P_{tot} | 420 | mW |
| | P_{tot} | 340 | mW |
| $T_{amb} = 60^\circ\text{C}$, DIP8 SO8 | P_{tot} | 690 | mW |
| | P_{tot} | 560 | mW |
| Junction temperature | T_j | 150 | $^\circ\text{C}$ |
| Ambient temperature range | T_{amb} | -40 to +95 | $^\circ\text{C}$ |
| Storage temperature range | T_{stg} | -55 to +150 | $^\circ\text{C}$ |

5. Thermal Resistance

| Parameters | Symbol | Value | Unit |
|------------------------|------------|-------|------|
| Junction ambient, DIP8 | R_{thJA} | 110 | K/W |
| Junction ambient, SO8 | R_{thJA} | 160 | K/W |

6. Electrical Characteristics

Typical values under normal operation in application circuit [Figure 1-1 on page 1](#), V_S (+49, pin 2 and pin 6) = 12V.
Reference point ground (-31), $T_{amb} = 25^\circ\text{C}$, unless otherwise specified

| Parameters | Test Conditions | Symbol | Min. | Typ. | Max. | Unit |
|---------------------------------|---|--------------|-------------------|---------|------------------|---------------|
| Supply voltage range | Pins 2, 6 | $V_S(+49)$ | | 9 to 15 | | V |
| Supply current | Dark phase or stand-by, pins 2, 6 | I_S | | 4.5 | 8 | mA |
| Supply current | Bright phase, pins 2, 6 | I_S | | 7.0 | 11 | mA |
| Relay output | Saturation voltage $I_O = 150$ mA, $V_S = 9$ V (pin 3) | V_O | | | 1.0 | V |
| Relay output reverse current | Pin 3 | I_O | | | 0.1 | mA |
| Relay coil resistance | | R_L | 60 | | | Ω |
| Start delay | First bright phase | t_{on} | | | 10 | ms |
| Frequency determining resistor | | R_1 | 6.8 | | 510 | k Ω |
| Frequency determining capacitor | | C_1 | | | 47 | μF |
| Frequency tolerance | Normal flashing, basic frequency f_1 not including the tolerance of the external components R_1 and C_1 | Δf_1 | -5 | | +5 | % |
| Bright period | Basic frequency f_1 | Δf_1 | 47 | | 53 | % |
| | Control frequency f_2 | Δf_2 | 37 | | 45 | % |
| Frequency increase | Lamp outage | f_2 | $2.15 \times f_1$ | | $2.3 \times f_1$ | Hz |
| Control signal threshold | $V_S = 15$ V (pin 7) | V_{R3} | 85 | 91 | 97 | mV |
| | $V_S = 9$ V | V_{R3} | 66 | 71 | 76 | mV |
| | $V_S = 12$ V | V_{R3} | 76 | 81 | 87 | mV |
| Leakage resistance | 49a to GND | R_p | | 2 | 5 | k Ω |
| Lamp load | | P_L | 10 | | | W |

7. Ordering Information

| Extended Type Number | Package | Remarks |
|----------------------|---------|---------------------------|
| U2043B-MY | DIP8 | Tubed, Pb-free |
| U2043B-MFPY | SO8 | Tubed, Pb-free |
| U2043B-MFPG3Y | SO8 | Taped and reeled, Pb-free |

8. Package Information

Package SO8

Dimensions in mm

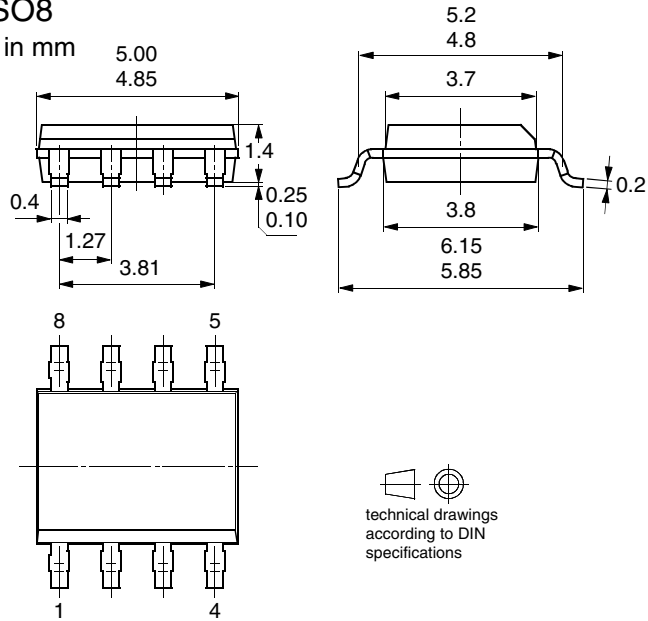

9. Revision History

Please note that the following page numbers referred to in this section refer to the specific revision mentioned, not to this document.

| Revision No. | History |
|------------------|---|
| 4720B-AUTO-09/05 | <ul style="list-style-type: none">• Put datasheet in a new template• Pb-free logo on page 1 added• New heading rows in Table “Absolute Maximum Rating” on page 5 added• Ordering Information on page 7 changed |



Atmel Corporation

2325 Orchard Parkway
San Jose, CA 95131, USA
Tel: 1(408) 441-0311
Fax: 1(408) 487-2600

Regional Headquarters

Europe

Atmel Sarl
Route des Arsenaux 41
Case Postale 80
CH-1705 Fribourg
Switzerland
Tel: (41) 26-426-5555
Fax: (41) 26-426-5500

Asia

Room 1219
Chinachem Golden Plaza
77 Mody Road Tsimshatsui
East Kowloon
Hong Kong
Tel: (852) 2721-9778
Fax: (852) 2722-1369

Japan

9F, Tonetsu Shinkawa Bldg.
1-24-8 Shinkawa
Chuo-ku, Tokyo 104-0033
Japan
Tel: (81) 3-3523-3551
Fax: (81) 3-3523-7581

Atmel Operations

Memory

2325 Orchard Parkway
San Jose, CA 95131, USA
Tel: 1(408) 441-0311
Fax: 1(408) 436-4314

Microcontrollers

2325 Orchard Parkway
San Jose, CA 95131, USA
Tel: 1(408) 441-0311
Fax: 1(408) 436-4314

La Chantrerie
BP 70602
44306 Nantes Cedex 3, France
Tel: (33) 2-40-18-18-18
Fax: (33) 2-40-18-19-60

ASIC/ASSP/Smart Cards

Zone Industrielle
13106 Rousset Cedex, France
Tel: (33) 4-42-53-60-00
Fax: (33) 4-42-53-60-01

1150 East Cheyenne Mtn. Blvd.
Colorado Springs, CO 80906, USA
Tel: 1(719) 576-3300
Fax: 1(719) 540-1759

Scottish Enterprise Technology Park
Maxwell Building
East Kilbride G75 0QR, Scotland
Tel: (44) 1355-803-000
Fax: (44) 1355-242-743

RF/Automotive

Theresienstrasse 2
Postfach 3535
74025 Heilbronn, Germany
Tel: (49) 71-31-67-0
Fax: (49) 71-31-67-2340

1150 East Cheyenne Mtn. Blvd.
Colorado Springs, CO 80906, USA
Tel: 1(719) 576-3300
Fax: 1(719) 540-1759

Biometrics/Imaging/Hi-Rel MPU/ High Speed Converters/RF Datacom

Avenue de Rochepleine
BP 123
38521 Saint-Egreve Cedex, France
Tel: (33) 4-76-58-30-00
Fax: (33) 4-76-58-34-80

Literature Requests

www.atmel.com/literature

Disclaimer: The information in this document is provided in connection with Atmel products. No license, express or implied, by estoppel or otherwise, to any intellectual property right is granted by this document or in connection with the sale of Atmel products. **EXCEPT AS SET FORTH IN ATMEL'S TERMS AND CONDITIONS OF SALE LOCATED ON ATMEL'S WEB SITE, ATMEL ASSUMES NO LIABILITY WHATSOEVER AND DISCLAIMS ANY EXPRESS, IMPLIED OR STATUTORY WARRANTY RELATING TO ITS PRODUCTS INCLUDING, BUT NOT LIMITED TO, THE IMPLIED WARRANTY OF MERCHANTABILITY, FITNESS FOR A PARTICULAR PURPOSE, OR NON-INFRINGEMENT. IN NO EVENT SHALL ATMEL BE LIABLE FOR ANY DIRECT, INDIRECT, CONSEQUENTIAL, PUNITIVE, SPECIAL OR INCIDENTAL DAMAGES (INCLUDING, WITHOUT LIMITATION, DAMAGES FOR LOSS OF PROFITS, BUSINESS INTERRUPTION, OR LOSS OF INFORMATION) ARISING OUT OF THE USE OR INABILITY TO USE THIS DOCUMENT, EVEN IF ATMEL HAS BEEN ADVISED OF THE POSSIBILITY OF SUCH DAMAGES.** Atmel makes no representations or warranties with respect to the accuracy or completeness of the contents of this document and reserves the right to make changes to specifications and product descriptions at any time without notice. Atmel does not make any commitment to update the information contained herein. Unless specifically provided otherwise, Atmel products are not suitable for, and shall not be used in, automotive applications. Atmel's products are not intended, authorized, or warranted for use as components in applications intended to support or sustain life.

© Atmel Corporation 2005. All rights reserved. Atmel®, logo and combinations thereof, Everywhere You Are® and others, are registered trademarks or trademarks of Atmel Corporation or its subsidiaries. Other terms and product names may be trademarks of others.



Printed on recycled paper.