

Features

- Identification Transponder in Plastic Cube
- Basic Component: e5530 IDIC®
- Includes Coil and Capacitor for Tuned Circuit Antenna
- Carrier Frequency: 125 kHz

Application

- Car Immobilizer
- Access Control
- Alarm Systems
- Other Identification Systems



Read-only Transponder

1. Description

The TK5530 is a complete transponder, which implements all important functions for immobilizer and identification systems. It consists of a plastic cube which accommodates the read-only IDentification Integral Circuit (IDIC) e5530 and the antenna is realized by a LC-circuit.

The identifying data are stored in a 128 bit PROM on the e5530, realized as an array of laser-programmable fuses. The logic block diagram for the e5530 is shown in [Figure 4-1 on page 2](#). The data are sent bit-serially as a code.

Any attempt to fake the base station with a wrong transponder will be recognized immediately.

Figure 1-1. System Block Diagram

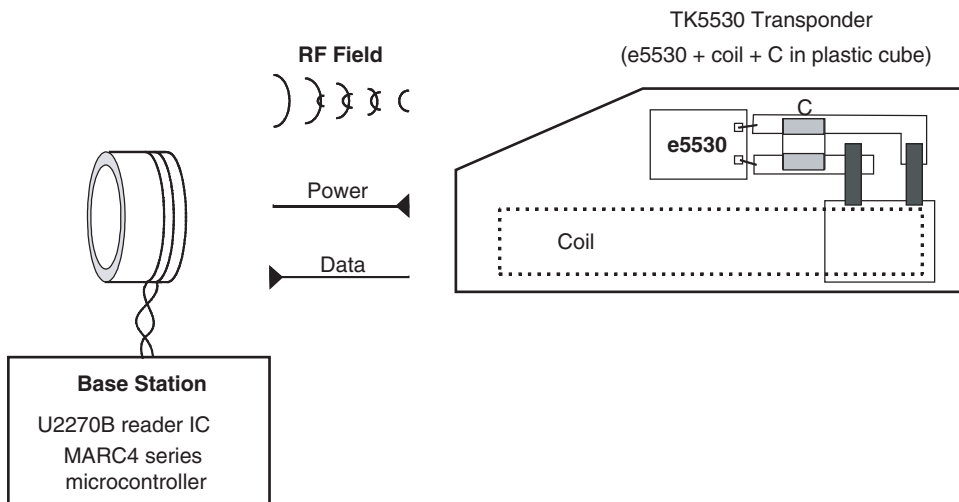

TK5530

2. General

The transponder consists of a plastic cube which accommodates following components:

- Read-only IDIC with ROM (e5530)
- Antenna realized as tuned LC-circuit

3. Read-Only IDIC with ROM (e5530)

The e5530 is part of a closed coupled identification system (see [Figure 1-1 on page 1](#)). It receives power from a RF transmitter (reader) which is coupled inductively to the IDIC. The TK5530 transponder operates at a nominal frequency of 125 kHz. Receiving RF, the IDIC responds with a data stream by damping the incoming RF via an internal load. This damping in turn can be detected by the reader. The identifying data are stored in a 128-bit PROM on the e5530, which is factory programmed with a unique code (see specification of the e5530).

The e5530 has several possible options regarding modulation, bitrate, memory size etc.

4. Antenna

The antenna consists of a coil and a capacitor for tuning the circuit to the nominal carrier frequency of 125 kHz. The coil has a ferrite-core for improving the readout distance.

Figure 4-1. Block Diagram

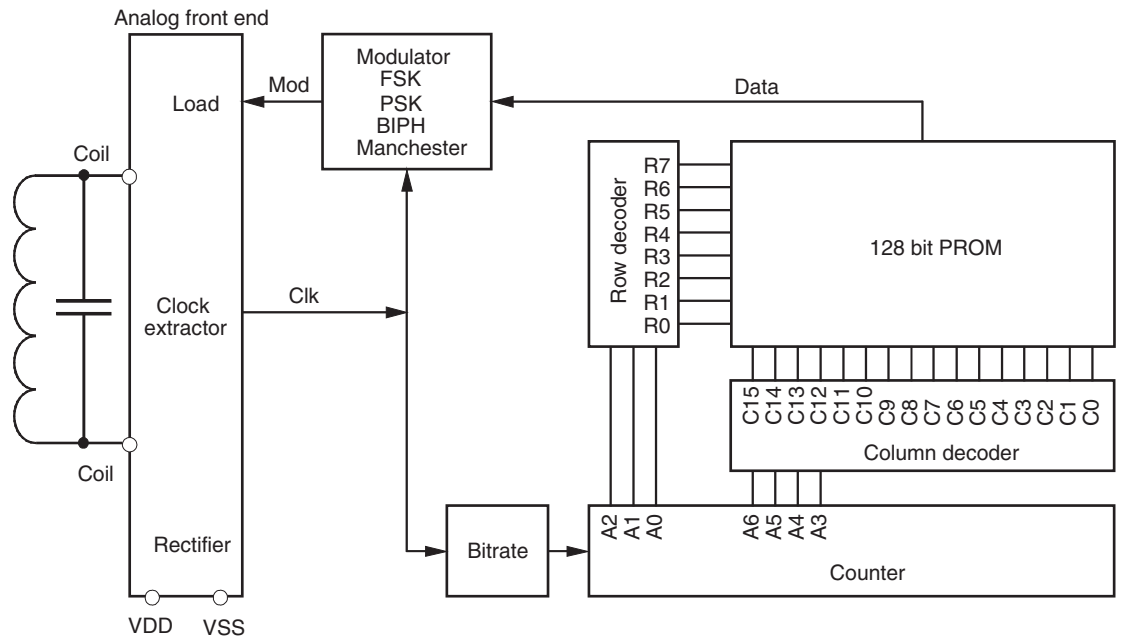

5. Absolute Maximum Ratings

Stresses beyond those listed under “Absolute Maximum Ratings” may cause permanent damage to the device. This is a stress rating only and functional operation of the device at these or any other conditions beyond those indicated in the operational sections of this specification is not implied. Exposure to absolute maximum rating conditions for extended periods may affect device reliability

| Parameter | Symbol | Value | Unit |
|------------------------------------|-----------|-------------|------|
| Operating temperature range | T_{amb} | -40 to +85 | °C |
| Storage temperature range | T_{stg} | -40 to +125 | °C |
| Assembly temperature $t < 5$ min | T_{ass} | 170 | °C |
| Magnetic field strength at 125 kHz | H_{pp} | 1000 | A/m |

6. Operating Characteristics Transponder

$T_{amb} = 25^{\circ}C$, $f = 125$ kHz unless otherwise specified

| Parameters | Test Conditions | Symbol | Min. | Typ. | Max. | Unit |
|---|---|---------------|-------|--------------------------|-------|------|
| Inductance | | L | | 3.95 | | mH |
| LC circuit, $H_{pp} = 20$ A/m | | | | | | |
| Resonance frequency | Room temperature | f_r | 121.4 | 125 | 129.2 | kHz |
| Resonance frequency | $T_{amb} = -40$ to $+85^{\circ}C$ | f_r | 120.0 | | 131.0 | kHz |
| Quality factor | | Q_{LC} | | 13 | | |
| Magnetic Field Strength (H) | | | | | | |
| Max. field strength where tag does not modulate | No influence to other tags in the field | $H_{pp\ not}$ | | 2 | | A/m |
| Field strength for operation | $T_{amb} = -40^{\circ}C$ | $H_{pp\ -40}$ | | 30 | | A/m |
| Field strength for operation | $T_{amb} = 25^{\circ}C$ | $H_{pp\ 25}$ | | 18 | | A/m |
| Field strength for operation | $T_{amb} = 85^{\circ}C$ | $H_{pp\ 85}$ | | 17 | | A/m |
| Maximum field strength | | $H_{pp\ max}$ | | | 600 | A/m |
| Modulation Range (See also H-DV Curve) | | | | | | |
| Modulation range | $H_{pp} = 20$ A/m $H_{pp} = 30$ A/m $H_{pp} = 50$ A/m $H_{pp} = 100$ A/m | DV | | 4.0 6.0 8.0 8.0 | | V |

Figure 6-1. Typical T_K -range of Resonance Frequency

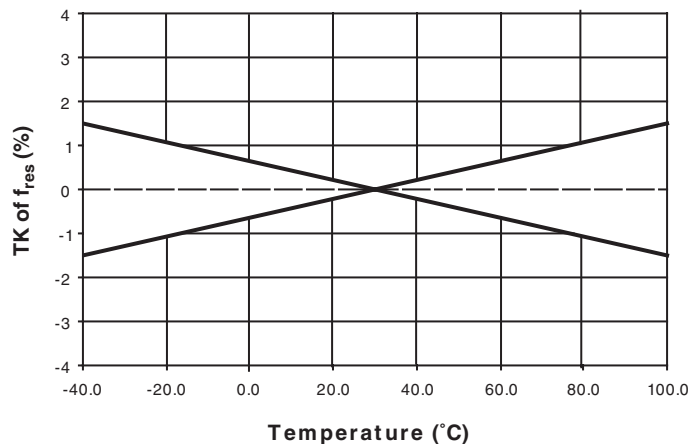

Figure 6-2. Typical H-DV Curve

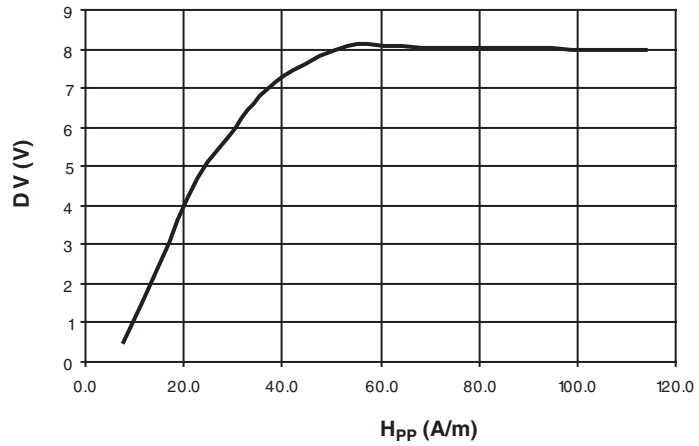
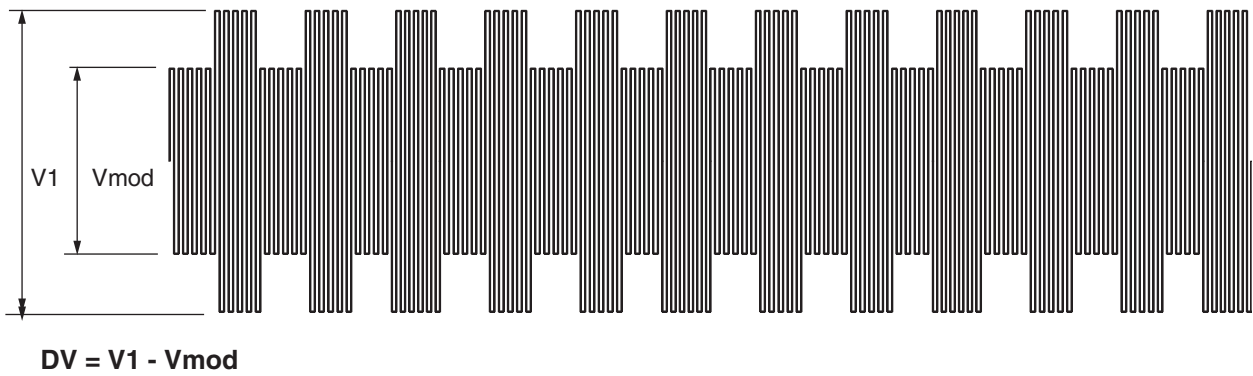

Figure 6-3. Measurement of the Modulation Range DV

Output Voltage of the Testing Application



7. Measurement Assembly

All parameters are measured in a Helmholtz-arrangement, which generates a homogenous magnetic field (see [Figure 7-1](#) and [Figure 7-2](#)). A function generator drives the field generating coils, so the magnetic field can be varied in frequency and field strength.

Figure 7-1. Testing Application

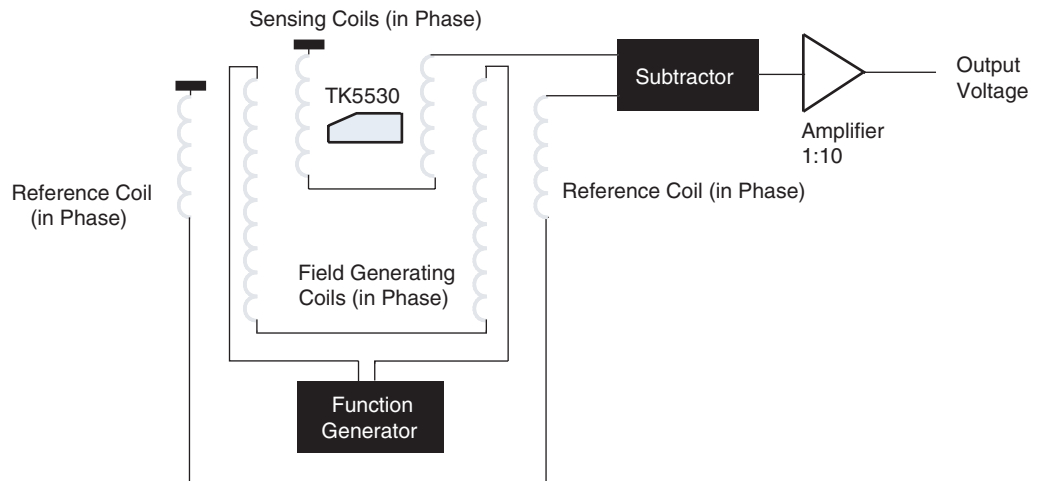
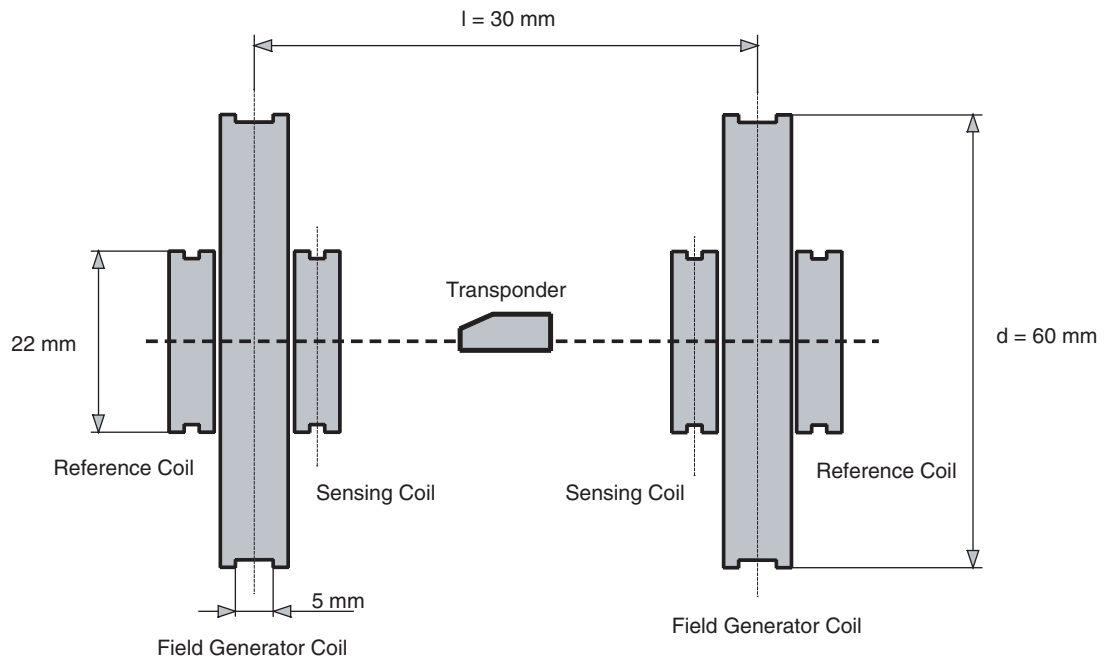

Figure 7-2. Testing Geometry



8. IDIC (Reference Data Sheet e5530)

| | |
|--|--------------------------------|
| Memory size maximum | 128 Bit (details see "Coding") |
| Memory type | ROM |
| Programming | Laser cutting |
| Data rate | RF/32 - RF/64 |
| Encoding | Manchester or Bi-phase |
| Modulation | AM |
| Maximum coil voltage (internally limited) V_{pp} ($I = 5 \text{ mA}$) | 16V |

8.1 Coding

The memory of the TK5530 can be selected to be a 64- or 128-bit rolling code. In the non-standard version, the first 8 bits are a customer-specific pattern. This can be selected by the customer, provided that Atmel agrees to the customer's proposal. This pattern is unique within the serial rolling code data stream. The ID code and further bit informations following the 8-bit header can also be defined within the customer's specification.

The set-up of a suitable coding scheme can be provided on customer's request.

8.2 Read Distance

The maximum distance between the base station and the TK5530 mainly depends on the base station, the coil geometries and the modulation options chosen (see U2270B Antenna Design Hints and the U2270B data sheet). When generating an appropriate field with a suitable reader technique, a distance of 10 cm and more can be obtained. When using the Atmel U2270B demo board, the typical distances in the range of 0 to 5 cm can be achieved. Maximum distance values which are generally valid can not be given in this data sheet. The exact measuring of the maximum distance should be carried out with the TK5530 being integrated into the specific application.

9. Application

Figure 9-1. Complete Transponder System with the Read/Write Base-station IC U2270B

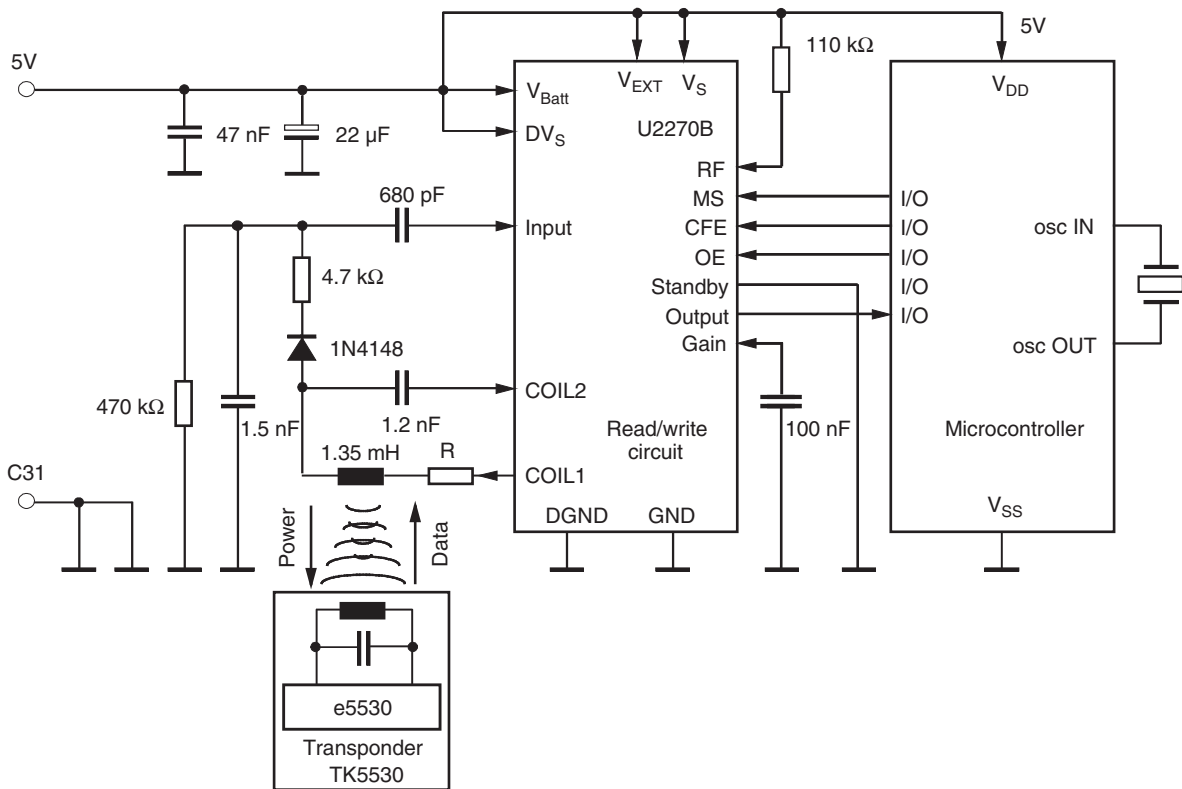

$$f_{\text{res}} = \frac{1}{2\pi\sqrt{LC}} = 125 \text{ kHz}$$

10. Ordering Information

| Extended Type Number | Modulation | Data Rate | Configuration | Checksum | Header | ID Code | SPQ (Minimum Volume) | Minimum Order Volume |
|----------------------|---------------------|-----------|---------------|--------------|--------|-----------------------|----------------------|---------------------------------|
| TK5530HM-232-PP | Manchester | RF/32 | 64 bit | no check-sum | E6 | fixed and unique code | 10 kpcs | >1 kpcs (per order, from stock) |
| TK5530HM-zzz-PP | defined by customer | | | | | | | > 300 kpcs p.a. |

1. Definition of customized part number basing on orders for first year volume (300 kpcs)
2. Definition of header, ID code, checksum etc. according to customers data base
3. 8.000 US\$ initial cost for metal mask
4. Lead time 5 month
5. Low volume customized application can be covered by TK5550F-PP programming, for identical application, as TK5530H-zzz-PP

10.1 Ordering Number for Standard Version

TK5530HM-232-PP

10.2 Ordering Number for Customized Version

TK5530xy-zzz-PP

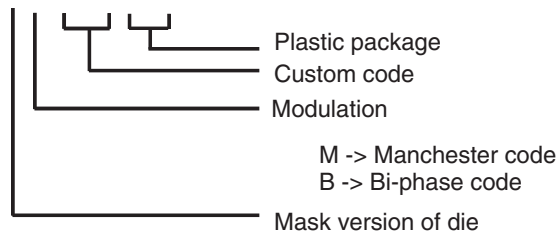

11. Package Information

Dimensions in mm

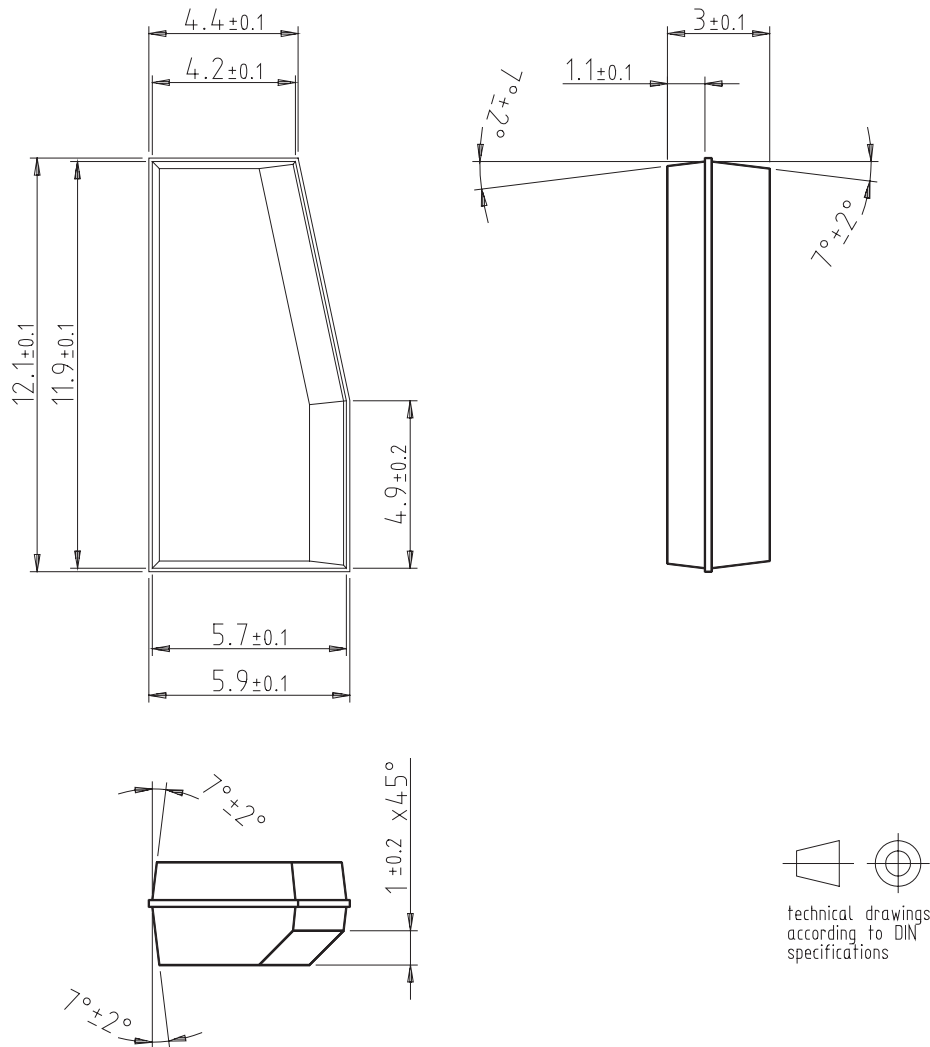

12. Revision History

Please note that the following page numbers referred to in this section refer to the specific revision mentioned, not to this document.

| Revision No. | History |
|------------------|---|
| 4863D-RFID-11/05 | <ul style="list-style-type: none"> Last page: Legal sentence changed |
| 4863C-RFID-08/05 | <ul style="list-style-type: none"> Figure 9-1 "Complete Transponder System with the Read/Write Base-station IC U2270B" on page 7 changed |
| 4863B-RFID-06/05 | <ul style="list-style-type: none"> Put datasheet in a new template Lead-free Logo on page 1 added |



Atmel Corporation

2325 Orchard Parkway
San Jose, CA 95131, USA
Tel: 1(408) 441-0311
Fax: 1(408) 487-2600

Regional Headquarters

Europe

Atmel Sarl
Route des Arsenaux 41
Case Postale 80
CH-1705 Fribourg
Switzerland
Tel: (41) 26-426-5555
Fax: (41) 26-426-5500

Asia

Room 1219
Chinachem Golden Plaza
77 Mody Road Tsimshatsui
East Kowloon
Hong Kong
Tel: (852) 2721-9778
Fax: (852) 2722-1369

Japan

9F, Tonetsu Shinkawa Bldg.
1-24-8 Shinkawa
Chuo-ku, Tokyo 104-0033
Japan
Tel: (81) 3-3523-3551
Fax: (81) 3-3523-7581

Atmel Operations

Memory

2325 Orchard Parkway
San Jose, CA 95131, USA
Tel: 1(408) 441-0311
Fax: 1(408) 436-4314

Microcontrollers

2325 Orchard Parkway
San Jose, CA 95131, USA
Tel: 1(408) 441-0311
Fax: 1(408) 436-4314

La Chantrerie
BP 70602
44306 Nantes Cedex 3, France
Tel: (33) 2-40-18-18-18
Fax: (33) 2-40-18-19-60

ASIC/ASSP/Smart Cards

Zone Industrielle
13106 Rousset Cedex, France
Tel: (33) 4-42-53-60-00
Fax: (33) 4-42-53-60-01

1150 East Cheyenne Mtn. Blvd.
Colorado Springs, CO 80906, USA
Tel: 1(719) 576-3300
Fax: 1(719) 540-1759

Scottish Enterprise Technology Park
Maxwell Building
East Kilbride G75 0QR, Scotland
Tel: (44) 1355-803-000
Fax: (44) 1355-242-743

RF/Automotive

Theresienstrasse 2
Postfach 3535
74025 Heilbronn, Germany
Tel: (49) 71-31-67-0
Fax: (49) 71-31-67-2340

1150 East Cheyenne Mtn. Blvd.
Colorado Springs, CO 80906, USA
Tel: 1(719) 576-3300
Fax: 1(719) 540-1759

Biometrics/Imaging/Hi-Rel MPU/ High Speed Converters/RF Datacom

Avenue de Rochepleine
BP 123
38521 Saint-Egreve Cedex, France
Tel: (33) 4-76-58-30-00
Fax: (33) 4-76-58-34-80

Literature Requests

www.atmel.com/literature

Disclaimer: The information in this document is provided in connection with Atmel products. No license, express or implied, by estoppel or otherwise, to any intellectual property right is granted by this document or in connection with the sale of Atmel products. **EXCEPT AS SET FORTH IN ATMEL'S TERMS AND CONDITIONS OF SALE LOCATED ON ATMEL'S WEB SITE, ATMEL ASSUMES NO LIABILITY WHATSOEVER AND DISCLAIMS ANY EXPRESS, IMPLIED OR STATUTORY WARRANTY RELATING TO ITS PRODUCTS INCLUDING, BUT NOT LIMITED TO, THE IMPLIED WARRANTY OF MERCHANTABILITY, FITNESS FOR A PARTICULAR PURPOSE, OR NON-INFRINGEMENT. IN NO EVENT SHALL ATMEL BE LIABLE FOR ANY DIRECT, INDIRECT, CONSEQUENTIAL, PUNITIVE, SPECIAL OR INCIDENTAL DAMAGES (INCLUDING, WITHOUT LIMITATION, DAMAGES FOR LOSS OF PROFITS, BUSINESS INTERRUPTION, OR LOSS OF INFORMATION) ARISING OUT OF THE USE OR INABILITY TO USE THIS DOCUMENT, EVEN IF ATMEL HAS BEEN ADVISED OF THE POSSIBILITY OF SUCH DAMAGES.** Atmel makes no representations or warranties with respect to the accuracy or completeness of the contents of this document and reserves the right to make changes to specifications and product descriptions at any time without notice. Atmel does not make any commitment to update the information contained herein. Unless specifically provided otherwise, Atmel products are not suitable for, and shall not be used in, automotive applications. Atmel's products are not intended, authorized, or warranted for use as components in applications intended to support or sustain life.

© Atmel Corporation 2005. All rights reserved. Atmel®, logo and combinations thereof, Everywhere You Are®, IDIC®, and others, are registered trademarks or trademarks of Atmel Corporation or its subsidiaries. Other terms and product names may be trademarks of others.



Printed on recycled paper.