



Features

- 10kV – ESD protection
- Two comparators with common reference
- Tight threshold tolerance
- Constant threshold
- NPN output
- Interference and damage-protection according to VDE 0839 and ISO/CD 7637 EMI protection
- Reversal polarity protection
- Load-dump protection

Description

The bipolar Atmel® U4793B is designed to monitor overload or a short circuit in automotive or industrial applications. The threshold is tied to $V_{4,6} = V_S - V_T$ where $V_T = 44.5\text{mV}$. It is independent of the supply voltage, V_S . If the voltage drop across shunt resistor, R_{sh} , exceeds this value, the output is turned on, otherwise the output is turned off.

Without supply voltage or open input pin 8, the output is turned off. The output breakdown voltage is determined by the Z-diodes Z_3 and Z_5 with a typical value of $V_Z = 22\text{V}$.

An unused comparator input must be connected to pin 7.

1. Block Diagram

Figure 1-1. Schematic and Application Circuit

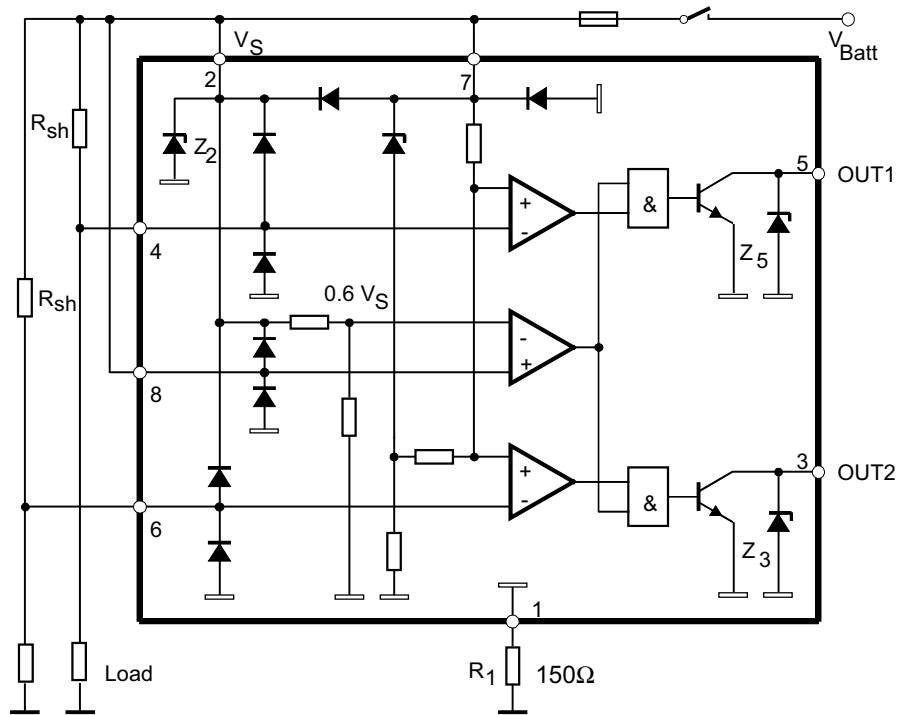

2. Pin Configuration

Figure 2-1. Pinning SO8

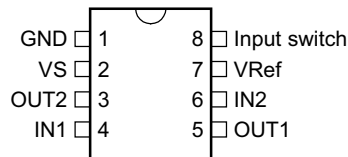

Table 2-1. Pin Description

Pin	Symbol	Function
1	GND	Reference point, ground
2	VS	Supply voltage
3	OUT2	Output 2
4	IN1	Input 1
5	OUT1	Output 1
6	IN2	Input 2
7	VRef	Reference voltage
8	Input switch	Input switch

3. Absolute Maximum Ratings

Stresses beyond those listed under “Absolute Maximum Ratings” may cause permanent damage to the device. This is a stress rating only and functional operation of the device at these or any other conditions beyond those indicated in the operational sections of this specification is not implied. Exposure to absolute maximum rating conditions for extended periods may affect device reliability.

Parameters	Symbol	Value	Unit
Supply voltage; pins 2 and 7	V_S	16.5	V
Current consumption $t = 2$ ms, measured at pin 1 (GND), pin 1	I_1	1.5	A
Output current, pins 3 and 5	$I_{3,5}$	20	mA
Input voltage reference point pin 7, pins 4 and 6	$-V_{4,6}$	6	V
Power dissipation			
$T_{amb} = 125^\circ\text{C}$	P_{tot}	150	mW
$T_{amb} = 95^\circ\text{C}$	P_{tot}	360	mW
$T_{amb} = 60^\circ\text{C}$	P_{tot}	560	mW
Ambient temperature range	T_{amb}	-40 to +125	$^\circ\text{C}$
Storage temperature range	T_{stg}	-55 to +125	$^\circ\text{C}$
Junction temperature	T_j	150	$^\circ\text{C}$

4. Thermal Resistance

Parameters	Symbol	Value	Unit
Junction ambient	R_{thJA}	160	K/W

5. Electrical Characteristics

$V_S = 9\text{V}$ to 15V , $T_{amb} = -40^\circ\text{C}$ to $+125^\circ\text{C}$, unless otherwise specified (see [Figure 1-1 on page 2](#))

No.	Parameters	Test Conditions	Pin	Symbol	Min.	Typ.	Max.	Unit	Type*
1	Supply								
1.1	Supply voltage		2, 7	V_S	9		15	V	A
1.2	Internal Z-diode Z_2		2	V_Z	20			V	A
1.3	Current consumption	$V_S = 12\text{V}$ measured $T_{amb} = -40^\circ\text{C}$	1	I_1	3.5	4.8	6.0	mA	C
1.4		$V_S = 12\text{V}$ measured $T_{amb} = 25^\circ\text{C}$	1	I_1	2.8	3.4	6.0	mA	A
1.5		$V_S = 12\text{V}$ measured $T_{amb} = 125^\circ\text{C}$	1	I_1	2.0	2.6	3.2	mA	C

*) Type means: A = 100% tested, B = 100% correlation tested, C = Characterized on samples, D = Design parameter

5. Electrical Characteristics (Continued)

$V_S = 9V$ to $15V$, $T_{amb} = -40^\circ C$ to $+125^\circ C$, unless otherwise specified (see Figure 1-1 on page 2)

No.	Parameters	Test Conditions	Pin	Symbol	Min.	Typ.	Max.	Unit	Type*
2 Output									
2.1	Output saturation voltage	$V_S = 9V$, $I_{3,5} = 10mA$ $T_{amb} = 25^\circ C$	3, 5	V_{sat}			0.5	V	A
2.2	Output Z-diodes Z_3, Z_5		3, 5	V_Z	21			V	A
3 Control Signal									
3.1		$I_{3,5} = 1mA$, Figure 5-1 $T_{amb} = -40^\circ C$	4, 6	$-V_T$	42	44	46	mV	C
3.2	Control signal threshold	$I_{3,5} = 1mA$, Figure 5-1 $T_{amb} = 25^\circ C$	4, 6	$-V_T$	43	44.5	46	mV	A
3.3		$I_{3,5} = 1mA$, Figure 5-1 $T_{amb} = 125^\circ C$	4, 6	$-V_T$	44.5	46	47.5	mV	C
3.4	Temperature coefficient of control signal threshold			TC		15		$\mu V/K$	C
3.5	Input currents	$T_{amb} = -40^\circ C$		I_I	100		190	nA	C
3.6	Pins connected to 12V	$T_{amb} = 25^\circ C$	4, 6	I_I	60	100	150	nA	A
3.7		$T_{amb} = 125^\circ C$		I_I	30		110	nA	C
3.8	Input currents	$T_{amb} = -40^\circ C$		I_I	5.5		7.0	μA	C
3.9	Pins connected to 12V	$T_{amb} = 25^\circ C$	8	I_I	4.0	5.0	5.5	μA	A
3.10		$T_{amb} = 125^\circ C$		I_I	3.0		4.5	μA	C
4 Threshold									
4.1	Threshold voltage	Switch identification $T_{amb} = -40^\circ C$	8	V_8	$0.47 \times V_S$		$0.69 \times V_S$	V	C
4.2		Switch identification $T_{amb} = 25^\circ C$		V_8	$0.47 \times V_S$	$0.6 V_S$	$0.69 \times V_S$	V	A
4.3		Switch identification $T_{amb} = 125^\circ C$		V_8	$0.47 \times V_S$		$0.69 \times V_S$	V	C
5 Switch Delay ($R_L = 10k\Omega$ connected from Pin 3 or Pin 5 to V_{Batt})									
5.1	Delay time	$T_{amb} = -40^\circ C$	3, 5	$t_{d(on)}$	3	4	6	μs	C
5.2	Switch-on	$T_{amb} = 25^\circ C$		$t_{d(on)}$	4	6	8	μs	C
5.3	High to low	$T_{amb} = 125^\circ C$		$t_{d(on)}$	5	7	9	μs	C
5.4	Delay time	$T_{amb} = -40^\circ C$		$t_{d(off)}$	16	24	32	μs	C
5.5	Switch-off	$T_{amb} = 25^\circ C$		$t_{d(off)}$	18	30	50	μs	A
5.6	Low to high	$T_{amb} = 125^\circ C$		$t_{d(off)}$	30	50	70	μs	C

*) Type means: A = 100% tested, B = 100% correlation tested, C = Characterized on samples, D = Design parameter

Figure 5-1. Timing Diagram

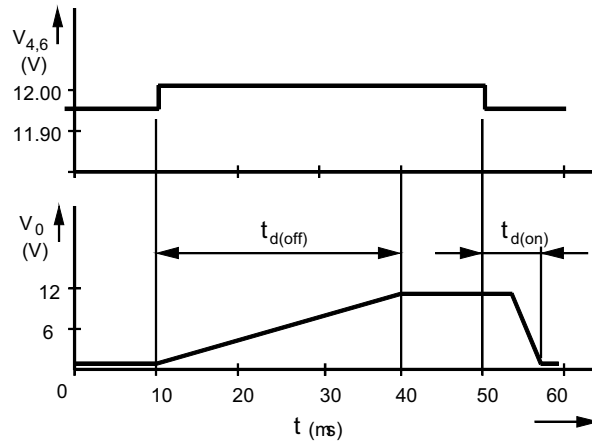
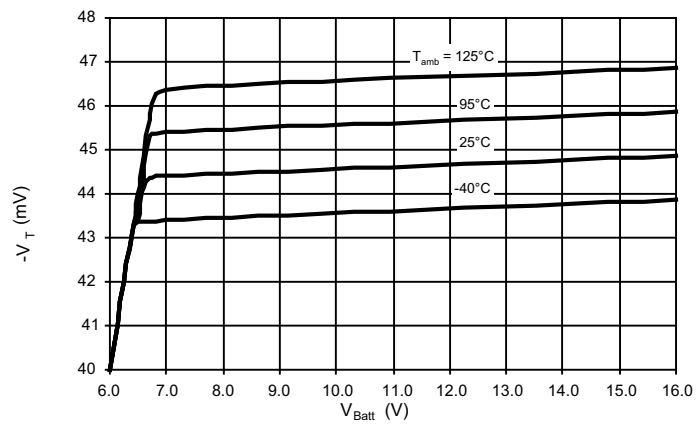

Figure 5-2. Threshold Voltage = $f(V_{Batt}$ and Temperature)



6. Ordering Information

Extended Type Number	Package	Remarks
U4793B-MFPY	SO8	Tube, Pb-free

7. Package Information

Figure 7-1. SO8

Package: SO 8

Dimensions in mm

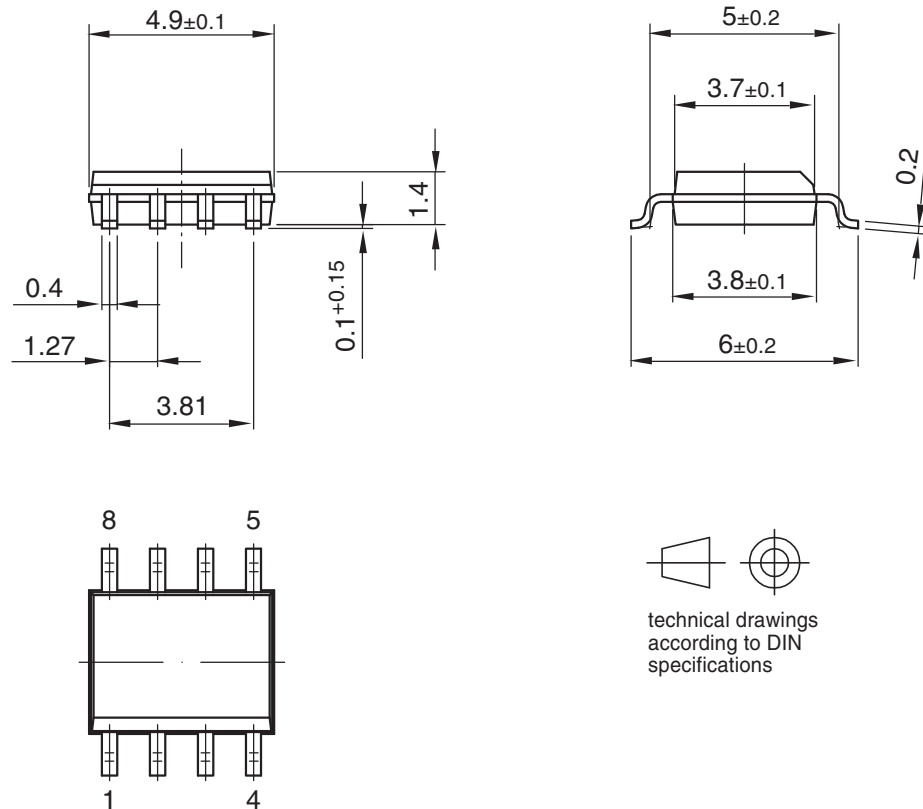

Drawing-No.: 6.541-5031.01-4

Issue: 1; 15.08.06

8. Revision History

Please note that the following page numbers referred to in this section refer to the specific revision mentioned, not to this document.

Revision No.	History
4557C-AUTO-06/12	<ul style="list-style-type: none">• Section 4 “Absolute Maximum Ratings” on page 3 changed• Section 5 “Thermal Resistance” on page 3 changed• Section 7 “Ordering Information” on page 6 changed• Section 8 “Package Information” on page 6 changed
4557B-AUTO-09/05	<ul style="list-style-type: none">• Put datasheet in a new template• Pb-free logo on page 1 added• Ordering Information on page 6 changed



Enabling Unlimited Possibilities™

Atmel Corporation

2325 Orchard Parkway
San Jose, CA 95131
USA

Tel: (+1) (408) 441-0311

Fax: (+1) (408) 487-2600

www.atmel.com

Atmel Asia Limited

Unit 01-5 & 16, 19F
BEA Tower, Millennium City 5
418 Kwun Tong Roa
Kwun Tong, Kowloon

HONG KONG

Tel: (+852) 2245-6100

Fax: (+852) 2722-1369

Atmel Munich GmbH

Business Campus
Parkring 4
D-85748 Garching b. Munich
GERMANY

Tel: (+49) 89-31970-0

Fax: (+49) 89-3194621

Atmel Japan G.K.

16F Shin-Osaki Kangyo Building
1-6-4 Osaki
Shinagawa-ku, Tokyo 141-0032
JAPAN

Tel: (+81) (3) 6417-0300

Fax: (+81) (3) 6417-0370

© 2012 Atmel Corporation. All rights reserved. / Rev.: 4557C-AUTO-06/12

Atmel®, Atmel logo and combinations thereof, Enabling Unlimited Possibilities®, and others are registered trademarks or trademarks of Atmel Corporation or its subsidiaries. Other terms and product names may be trademarks of others.

Disclaimer: The information in this document is provided in connection with Atmel products. No license, express or implied, by estoppel or otherwise, to any intellectual property right is granted by this document or in connection with the sale of Atmel products. EXCEPT AS SET FORTH IN THE ATMEL TERMS AND CONDITIONS OF SALES LOCATED ON THE ATMEL WEBSITE, ATMEL ASSUMES NO LIABILITY WHATSOEVER AND DISCLAIMS ANY EXPRESS, IMPLIED OR STATUTORY WARRANTY RELATING TO ITS PRODUCTS INCLUDING, BUT NOT LIMITED TO, THE IMPLIED WARRANTY OF MERCHANTABILITY, FITNESS FOR A PARTICULAR PURPOSE, OR NON-INFRINGEMENT. IN NO EVENT SHALL ATMEL BE LIABLE FOR ANY DIRECT, INDIRECT, CONSEQUENTIAL, PUNITIVE, SPECIAL OR INCIDENTAL DAMAGES (INCLUDING, WITHOUT LIMITATION, DAMAGES FOR LOSS AND PROFITS, BUSINESS INTERRUPTION, OR LOSS OF INFORMATION) ARISING OUT OF THE USE OR INABILITY TO USE THIS DOCUMENT, EVEN IF ATMEL HAS BEEN ADVISED OF THE POSSIBILITY OF SUCH DAMAGES. Atmel makes no representations or warranties with respect to the accuracy or completeness of the contents of this document and reserves the right to make changes to specifications and products descriptions at any time without notice. Atmel does not make any commitment to update the information contained herein. Unless specifically provided otherwise, Atmel products are not suitable for, and shall not be used in, automotive applications. Atmel products are not intended, authorized, or warranted for use as components in applications intended to support or sustain life.