

Features

- 80C52 Compatible
 - 8051 Pin and Instruction Compatible
 - Four 8-bit I/O Ports (or 6 in 64/68 Pins Packages)
 - Three 16-bit Timer/Counters
 - 256 bytes Scratch Pad RAM
 - 7 Interrupt Sources With 4 Priority Levels
- ISP (In-System Programming) Using Standard V_{CC} Power Supply
- Boot Flash Contains Low Level Flash Programming Routines and a Default Serial Loader
- High-Speed Architecture
 - 40 MHz in Standard Mode
 - 20 MHz in X2 Mode (6 Clocks/Machine Cycle)
- 64K bytes On-chip Flash Program/Data Memory
 - Byte and Page (128 bytes) Erase and Write
 - 100K Write Cycles
- On-chip 1024 Bytes Expanded RAM (XRAM)
 - Software Selectable Size (0, 256, 512, 768, 1024 bytes)
 - 768 Bytes Selected at Reset for T87C51RD2 Compatibility
- Dual Data Pointer
 - Variable Length MOVX for Slow RAM/Peripherals
- Improved X2 Mode with Independent Selection for CPU and Each Peripheral
- 2K bytes EEPROM Block for Data Storage
 - 100K Write Cycle
- Programmable Counter Array with
 - High Speed Output
 - Compare/Capture
 - Pulse Width Modulator
 - Watchdog Timer Capabilities
 - Asynchronous Port Reset
 - Full-duplex Enhanced UART
 - Low EMI (Inhibit ALE)
 - Hardware Watchdog Timer (One-time Enabled with Reset-out)
- Power Control Modes:
 - Idle Mode
 - Power-down Mode
- Power Supply:
 - M version: Commercial and Industrial
 - 4.5V to 5.5V: 40 MHz (X1 Mode), 20 MHz (X2 Mode)
 - 3V to 5.5V: 33 MHz (X1 Mode), 16 MHz (X2 Mode)
 - L version: Commercial and industrial
 - 2.7V to 3.6V: 25 MHz (X1 Mode), 12 MHz (X2 Mode)
- Temperature Ranges: Commercial (0 to +70°C) and Industrial (-40 to +85°C)
- Packages: PDIL40, PLCC44, VQFP44, PLCC68, VQFP64



**0 to 40 MHz
Flash
Programmable
8-bit
Microcontroller**

T89C51RD2

Rev. 4243G-8051-05/03





Description

T89C51RD2 is high performance CMOS Flash version of the 80C51 CMOS single chip 8-bit microcontroller. It contains a 64 Kbytes Flash memory block for program and for data.

The 64 Kbytes Flash memory can be programmed either in parallel mode or in serial mode with the ISP capability or with software. The programming voltage is internally generated from the standard V_{CC} pin.

The T89C51RD2 retains all features of the ATMEL 80C52 with 256 bytes of internal RAM, a 7-source 4-level interrupt controller and three timer/counters.

In addition, the T89C51RD2 has a Programmable Counter Array, an XRAM of 1024 bytes, an EEPROM of 2048 bytes, a Hardware Watchdog Timer, a more versatile serial channel that facilitates multiprocessor communication (EUART) and a speed improvement mechanism (X2 mode). Pinout is either the standard 40/44 pins of the C52 or an extended version with 6 ports in a 64/68 pins package.

The fully static design of the T89C51RD2 allows to reduce system power consumption by bringing the clock frequency down to any value, even DC, without loss of data.

The T89C51RD2 has 2 software-selectable modes of reduced activity for further reduction in power consumption. In the idle mode the CPU is frozen while the peripherals and the interrupt system are still operating. In the power-down mode the RAM is saved and all other functions are inoperative.

The added features of the T89C51RD2 makes it more powerful for applications that need pulse width modulation, high speed I/O and counting capabilities such as alarms, motor control, corded phones, smart card readers.

Table 1. Memory Size

PDIL40 PLCC44 VQFP44 1.4	Flash (bytes)	EEPROM (bytes)	XRAM (bytes)	TOTAL RAM (bytes)	I/O
T89C51RD2	64K	2K	1024	1280	32

PLCC68 VQFP64 1.4	Flash (bytes)	EEPROM (bytes)	XRAM (bytes)	TOTAL RAM (bytes)	I/O
T89C51RD2	64K	2K	1024	1280	48

Block Diagram

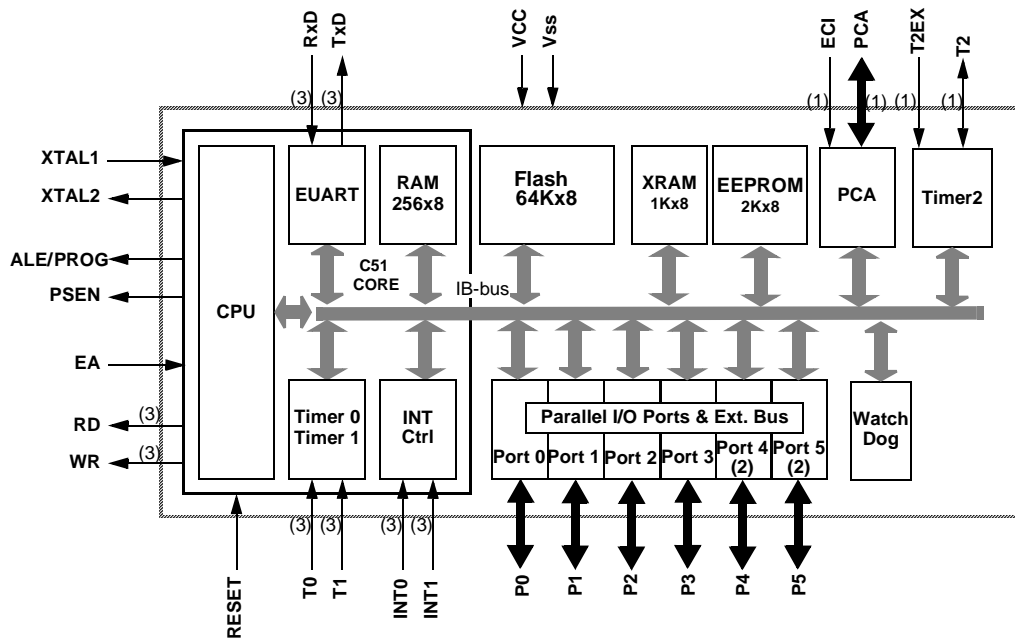

- Notes:
1. Alternate function of Port 1.
 2. Only available on high pin count packages.
 3. Alternate function of Port 3.

Pin Configuration

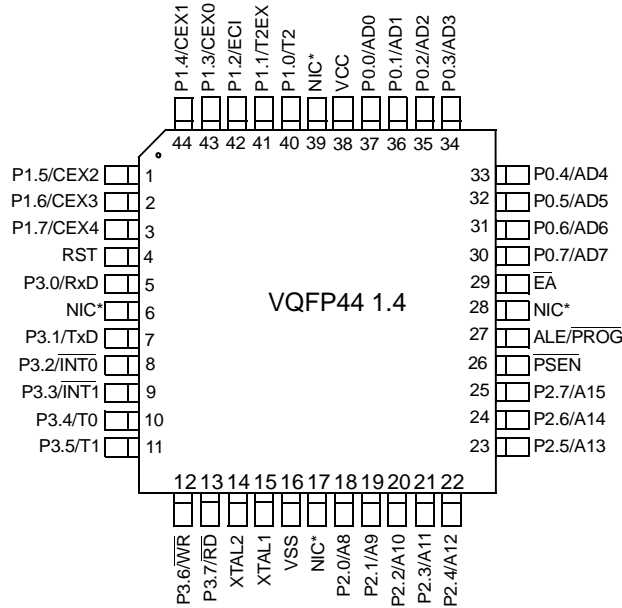
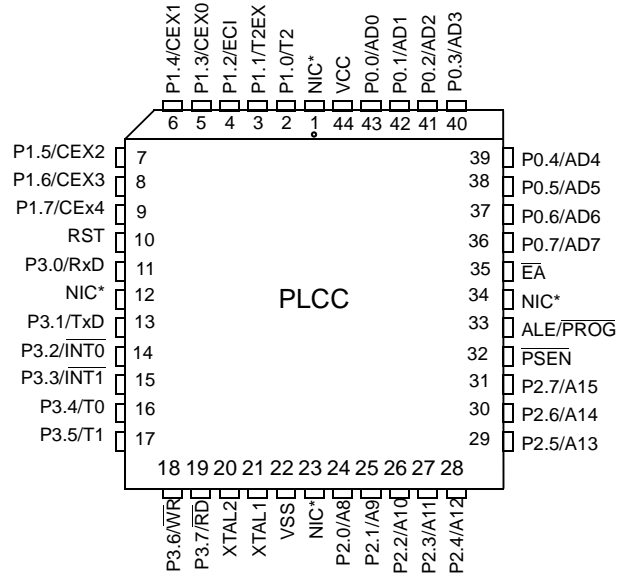
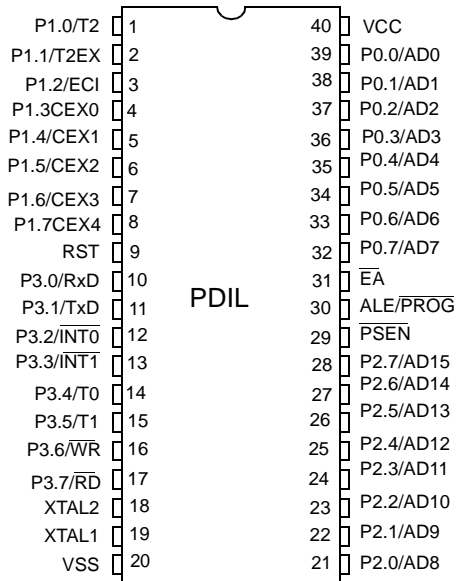

Note: NIC = No Internal Connection

Table 2. Pin Description

Mnemonic	Pin Number			Type	Name and Function
	DIL	LCC	VQFP 1.4		
V _{SS}	20	22	16	I	Ground: 0V reference
V _{SS1}		1	39	I	Optional Ground: Contact the Sales Office for ground connection.
V _{CC}	40	44	38	I	Power Supply: This is the power supply voltage for normal, idle and power-down operation
P0.0-P0.7	39-32	43-36	37-30	I/O	Port 0: Port 0 is an open-drain, bidirectional I/O port. Port 0 pins that have 1s written to them float and can be used as high impedance inputs. Port 0 must be polarized to V _{CC} or V _{SS} in order to prevent any parasitic current consumption. Port 0 is also the multiplexed low-order address and data bus during access to external program and data memory. In this application, it uses strong internal pull-up when emitting 1s. Port 0 also inputs the code bytes during EPROM programming. External pull-ups are required during program verification during which P0 outputs the code bytes.
P1.0-P1.7	1-8	2-9	40-44 1-3	I/O	Port 1: Port 1 is an 8-bit bidirectional I/O port with internal pull-ups. Port 1 pins that have 1s written to them are pulled high by the internal pull-ups and can be used as inputs. As inputs, Port 1 pins that are externally pulled low will source current because of the internal pull-ups. Port 1 also receives the low-order address byte during memory programming and verification. Alternate functions for TSC8x54/58 Port 1 include:
	1	2	40	I/O	T2 (P1.0): Timer/Counter 2 external count input/Clockout
	2	3	41	I	T2EX (P1.1): Timer/Counter 2 Reload/Capture/Direction Control
	3	4	42	I	ECI (P1.2): External Clock for the PCA
	4	5	43	I/O	CEX0 (P1.3): Capture/Compare External I/O for PCA module 0
	5	6	44	I/O	CEX1 (P1.4): Capture/Compare External I/O for PCA module 1
	6	7	1	I/O	CEX2 (P1.5): Capture/Compare External I/O for PCA module 2
	7	8	2	I/O	CEX3 (P1.6): Capture/Compare External I/O for PCA module 3
	8	9	3	I/O	CEX4 (P1.7): Capture/Compare External I/O for PCA module 4
P2.0-P2.7	21-28	24-31	18-25	I/O	Port 2: Port 2 is an 8-bit bidirectional I/O port with internal pull-ups. Port 2 pins that have 1s written to them are pulled high by the internal pull-ups and can be used as inputs. As inputs, Port 2 pins that are externally pulled low will source current because of the internal pull-ups. Port 2 emits the high-order address byte during fetches from external program memory and during accesses to external data memory that use 16-bit addresses (MOVX @DPTR). In this application, it uses strong internal pull-ups emitting 1s. During accesses to external data memory that use 8-bit addresses (MOVX @Ri), port 2 emits the contents of the P2 SFR. Some Port 2 pins receive the high order address bits during EPROM programming and verification: P2.0 to P2.5 for RB devices P2.0 to P2.6 for RC devices P2.0 to P2.7 for RD devices.
P3.0-P3.7	10-17	11, 13-19	5, 7-13	I/O	Port 3: Port 3 is an 8-bit bidirectional I/O port with internal pull-ups. Port 3 pins that have 1s written to them are pulled high by the internal pull-ups and can be used as inputs. As inputs, Port 3 pins that are externally pulled low will source current because of the internal pull-ups. Port 3 also serves the special features of the 80C51 family, as listed below.
	10	11	5	I	RXD (P3.0): Serial input port
	11	13	7	O	TXD (P3.1): Serial output port

Table 2. Pin Description (Continued)

Mnemonic	Pin Number			Type	Name and Function
	DIL	LCC	VQFP 1.4		
	12	14	8	I	$\overline{\text{INT0}}$ (P3.2): External interrupt 0
	13	15	9	I	$\overline{\text{INT1}}$ (P3.3): External interrupt 1
	14	16	10	I	T0 (P3.4): Timer 0 external input
	15	17	11	I	T1 (P3.5): Timer 1 external input
	16	18	12	O	$\overline{\text{WR}}$ (P3.6): External data memory write strobe
	17	19	13	O	$\overline{\text{RD}}$ (P3.7): External data memory read strobe
Reset	9	10	4	I/O	Reset: A high on this pin for two machine cycles while the oscillator is running, resets the device. An internal diffused resistor to V_{SS} permits a power-on reset using only an external capacitor to V_{CC} . This pin is an output when the hardware watchdog forces a system reset.
$\overline{\text{ALE/PROG}}$	30	33	27	O (I)	Address Latch Enable/Program Pulse: Output pulse for latching the low byte of the address during an access to external memory. In normal operation, ALE is emitted at a constant rate of 1/6 (1/3 in X2 mode) the oscillator frequency, and can be used for external timing or clocking. Note that one ALE pulse is skipped during each access to external data memory. This pin is also the program pulse input (PROG) during Flash programming. ALE can be disabled by setting SFR's AUXR.0 bit. With this bit set, ALE will be inactive during internal fetches.
PSEN	29	32	26	O	Program Store ENable: The read strobe to external program memory. When executing code from the external program memory, PSEN is activated twice each machine cycle, except that two PSEN activations are skipped during each access to external data memory. PSEN is not activated during fetches from internal program memory.
EA	31	35	29	I	External Access Enable: $\overline{\text{EA}}$ must be externally held low to enable the device to fetch code from external program memory locations 0000H to FFFFH (RD). If security level 1 is programmed, $\overline{\text{EA}}$ will be internally latched on Reset.
XTAL1	19	21	15	I	Crystal 1: Input to the inverting oscillator amplifier and input to the internal clock generator circuits.
XTAL2	18	20	14	O	Crystal 2: Output from the inverting oscillator amplifier

SFR Mapping

The Special Function Registers (SFRs) of the T89C51RD2 fall into the following categories:

- C51 core registers: ACC, B, DPH, DPL, PSW, SP, AUXR1
- I/O port registers: P0, P1, P2, P3, P4, P5
- Timer registers: T2CON, T2MOD, TCON, TH0, TH1, TH2, TMOD, TL0, TL1, TL2, RCAP2L, RCAP2H
- Serial I/O port registers: SADDR, SADEN, SBUF, SCON
- Power and clock control registers: PCON
- Hardware Watchdog Timer register: WDTRST, WDTPRG
- Interrupt system registers: IE, IP, IPH
- Flash and EEPROM registers: FCON, EECON, EETIM
- Others: AUXR, AUXR1, CKCON

Table 3 below shows all SFRs with their address and their reset value.

Table 3. SFR Table

	Bit	Non Bit addressable							
	Addressable	1/9	2/A	3/B	4/C	5/D	6/E	7/F	
F8h	0/8	CH 0000 0000	CCAP0H XXXX XXXX	CCAP1H XXXX XXXX	CCAP2H XXXX XXXX	CCAP3H XXXX XXXX	CCAP4H XXXX XXXX		FFh
F0h	B 0000 0000								F7h
E8h	P5 1111 1111	CL 0000 0000	CCAP0L XXXX XXXX	CCAP1L XXXX XXXX	CCAP2L XXXX XXXX	CCAP3L XXXX XXXX	CCAP4L XXXX XXXX		EFh
E0h	ACC 0000 0000								E7h
D8h	CCON 00X0 0000	CMOD 00XX X000	CCAPM0 X000 0000	CCAPM1 X000 0000	CCAPM2 X000 0000	CCAPM3 X000 0000	CCAPM4 X000 0000		DFh
D0h	PSW 0000 0000	FCON XXXX 0000	EECON XXXX XX00	EETIM 0000 0000					D7h
C8h	T2CON 0000 0000	T2MOD XXXX XX00	RCAP2L 0000 0000	RCAP2H 0000 0000	TL2 0000 0000	TH2 0000 0000			CFh
C0h	P4 1111 1111							P5 1111 1111	C7h
B8h	IP X000 000	SADEN 0000 0000							BFh
B0h	P3 1111 1111							IPH X000 0000	B7h
A8h	IE 0000 0000	SADDR 0000 0000							AFh
A0h	P2 1111 1111		AUXR1 XXXX 00X0				WDRST XXXX XXXX	WDTPRG XXXX X000	A7h
98h	SCON 0000 0000	SBUF XXXX XXXX							9Fh
90h	P1 1111 1111								97h
88h	TCON 0000 0000	TMOD 0000 0000	TL0 0000 0000	TL1 0000 0000	TH0 0000 0000	TH1 0000 0000	AUXR XX0X 1000	CKCON X000 0000	8Fh
80h	P0 1111 1111	SP 0000 0111	DPL 0000 0000	DPH 0000 0000				PCON 00X1 0000	87h
	0/8	1/9	2/A	3/B	4/C	5/D	6/E	7/F	

 reserved

Enhanced Features

In comparison to the original 80C52, the T89C51RD2 implements some new features, which are:

- The X2 option
- The Dual Data Pointer
- The extended RAM
- The Programmable Counter Array (PCA)
- The Watchdog
- The 4 level interrupt priority system
- The power-off flag
- The ONCE mode
- The ALE disabling
- Some enhanced features are also located in the UART and the Timer 2

X2 Feature and Clock Generation

The T89C51RD2 core needs only 6 clock periods per machine cycle. This feature called "X2" provides the following advantages:

- Divide frequency crystals by 2 (cheaper crystals) while keeping same CPU power.
- Save power consumption while keeping same CPU power (oscillator power saving).
- Save power consumption by dividing dynamically operating frequency by 2 in operating and idle modes.
- Increase CPU power by 2 while keeping same crystal frequency.

In order to keep the original C51 compatibility, a divider by 2 is inserted between the XTAL1 signal and the main clock input of the core (phase generator). This divider may be disabled by software.

Description

The clock for the whole circuit and peripheral is first divided by two before being used by the CPU core and peripherals. This allows any cyclic ratio to be accepted on XTAL1 input. In X2 mode, as this divider is bypassed, the signals on XTAL1 must have a cyclic ratio between 40 to 60%. Figure 1 shows the clock generation block diagram. X2 bit is validated on XTAL1÷2 rising edge to avoid glitches when switching from X2 to STD mode. Figure 2 shows the mode switching waveforms.

Figure 1. Clock Generation Diagram

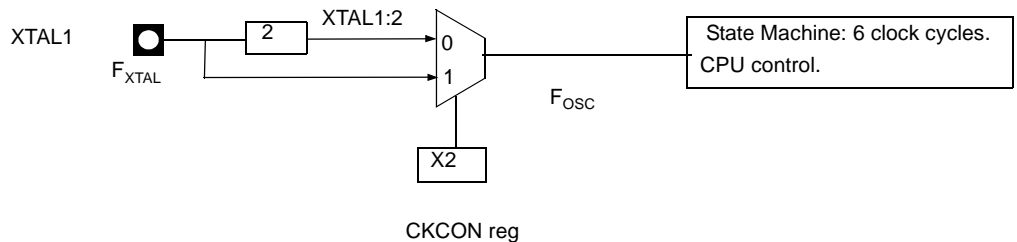
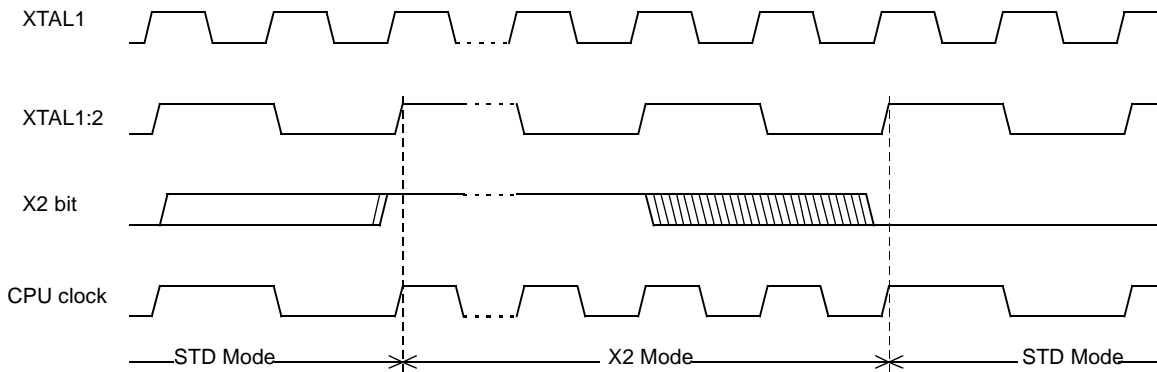

Figure 2. Mode Switching Waveforms



The X2 bit in the CKCON register (Table 4) allows to switch from 12 clock periods per instruction to 6 clock periods and vice versa. At reset, the standard speed is activated (STD mode). Setting this bit activates the X2 feature (X2 mode).

The T0X2, T1X2, T2X2, SiX2, PcaX2 and WdX2 bits in the CKCON register (Table 4) allow to switch from standard peripheral speed (12 clock periods per peripheral clock cycle) to fast peripheral speed (6 clock periods per peripheral clock cycle). These bits are active only in X2 mode.

More information about the X2 mode can be found in the application note ANM072 "How to take advantage of the X2 features in TS80C51 microcontroller".

Table 4. CKCON Register
CKCON - Clock Control Register (8Fh)

7	6	5	4	3	2	1	0
-	WdX2	PcaX2	SiX2	T2X2	T1X2	T0X2	X2
Bit Number	Bit Mnemonic	Description					
7	-	Reserved					
6	WdX2	Watchdog clock (This control bit is validated when the CPU clock X2 is set; when X2 is low, this bit has no effect) Clear to select 6 clock periods per peripheral clock cycle. Set to select 12 clock periods per peripheral clock cycle.					
5	PcaX2	Programmable Counter Array clock (This control bit is validated when the CPU clock X2 is set; when X2 is low, this bit has no effect) Clear to select 6 clock periods per peripheral clock cycle. Set to select 12 clock periods per peripheral clock cycle.					
4	SiX2	Enhanced UART clock (Mode 0 and 2) (This control bit is validated when the CPU clock X2 is set; when X2 is low, this bit has no effect) Clear to select 6 clock periods per peripheral clock cycle. Set to select 12 clock periods per peripheral clock cycle.					
3	T2X2	Timer2 clock (This control bit is validated when the CPU clock X2 is set; when X2 is low, this bit has no effect) Clear to select 6 clock periods per peripheral clock cycle. Set to select 12 clock periods per peripheral clock cycle.					

Bit Number	Bit Mnemonic	Description
2	T1X2	Timer1 clock (This control bit is validated when the CPU clock X2 is set; when X2 is low, this bit has no effect) Clear to select 6 clock periods per peripheral clock cycle. Set to select 12 clock periods per peripheral clock cycle
1	T0X2	Timer0 clock (This control bit is validated when the CPU clock X2 is set; when X2 is low, this bit has no effect) Clear to select 6 clock periods per peripheral clock cycle. Set to select 12 clock periods per peripheral clock cycle
0	X2	CPU clock Clear to select 12 clock periods per machine cycle (STD mode) for CPU and all the peripherals. Set to select 6 clock periods per machine cycle (X2 mode) and to enable the individual peripherals "X2" bits.

Reset Value = X000 0000b

Not bit addressable

Dual Data Pointer Register Ddptr

The additional data pointer can be used to speed up code execution and reduce code size.

The dual DPTR structure is a way by which the chip will specify the address of an external data memory location. There are two 16-bit DPTR registers that address the external memory, and a single bit called DPS = AUXR1/bit0 (See Table 5.) that allows the program code to switch between them (Refer to Figure 3).

Figure 3. Use of Dual Pointer

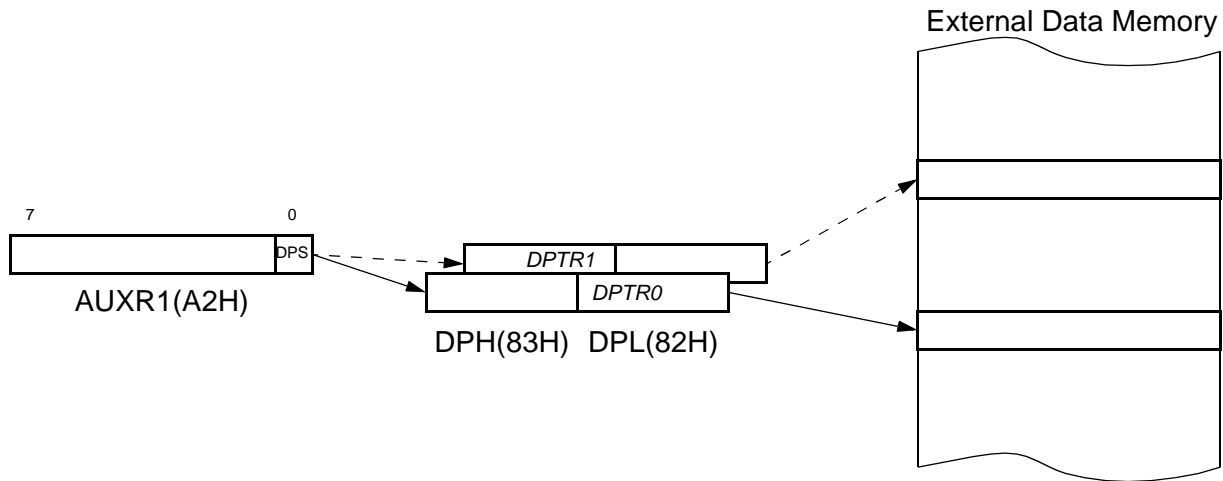

Table 5. AUXR1: Auxiliary Register 1

AUXR1 Address 0A2H	-	-	-	-	GF3	0	-	DPS
Reset value	X	X	X	X	0	0	X	0

Symbol	Function
-	Not implemented, reserved for future use. ⁽¹⁾
DPS	Data Pointer Selection.
	DPS Operating Mode
	0 DPTR0 Selected
1 DPTR1 Selected	
GF3	This bit is a general purpose user flag ⁽²⁾ .

1. User software should not write 1s to reserved bits. These bits may be used in future 8051 family products to invoke new feature. In that case, the reset value of the new bit will be 0, and its active value will be 1. The value read from a reserved bit is indeterminate.
2. Bit 2 stuck at 0; this allows to use INC AUXR1 to toggle DPS without changing GF3.

Application

Software can take advantage of the additional data pointers to both increase speed and reduce code size, for example, block operations (copy, compare, search ...) are well served by using one data pointer as a 'source' pointer and the other one as a "destination" pointer.

ASSEMBLY LANGUAGE

```

; Block move using dual data pointers
; Modifies DPTR0, DPTR1, A and PSW
; note: DPS exits opposite of entry state
; unless an extra INC AUXR1 is added
;
00A2  AUXR1 EQU 0A2H
;
0000 909000MOV DPTR,#SOURCE ; address of SOURCE
0003 05A2 INC AUXR1 ; switch data pointers
0005 90A000 MOV DPTR,#DEST ; address of DEST
0008  LOOP:
0008 05A2 INC AUXR1 ; switch data pointers
000A E0 MOVX A,@DPTR ; get a byte from SOURCE
000B A3 INC DPTR ; increment SOURCE address
000C 05A2 INC AUXR1 ; switch data pointers
000E F0 MOVX @DPTR,A ; write the byte to DEST
000F A3 INC DPTR ; increment DEST address
0010 70F6JNZ LOOP ; check for 0 terminator
0012 05A2 INC AUXR1 ; (optional) restore DPS

```

INC is a short (2 bytes) and fast (12 clocks) way to manipulate the DPS bit in the AUXR1 SFR. However, note that the INC instruction does not directly force the DPS bit to a particular state, but simply toggles it. In simple routines, such as the block move example, only the fact that DPS is toggled in the proper sequence matters, not its actual value. In other words, the block move routine works the same whether DPS is '0' or '1' on entry. Observe that without the last instruction (INC AUXR1), the routine will exit with DPS in the opposite state.

Expanded RAM (XRAM)

The T89C51RD2 provide additional Bytes of random access memory (RAM) space for increased data parameter handling and high level language usage.

T89C51RD2 devices have expanded RAM in external data space; Maximum size and location are described in Table 6.

Table 6. Description of Expanded RAM

Port	XRAM size	Address	
		Start	End
T89C51RD2	1024	00h	3FFh

The T89C51RD2 has internal data memory that is mapped into four separate segments.

The four segments are:

- 1. The Lower 128 bytes of RAM (addresses 00H to 7FH) are directly and indirectly addressable.
- 2. The Upper 128 bytes of RAM (addresses 80H to FFH) are indirectly addressable only.
- 3. The Special Function Registers, SFRs, (addresses 80H to FFH) are directly addressable only.
- 4. The expanded RAM bytes are indirectly accessed by MOVX instructions, and with the EXTRAM bit cleared in the AUXR register. (See Table 7.)

The Lower 128 bytes can be accessed by either direct or indirect addressing. The Upper 128 bytes can be accessed by indirect addressing only. The Upper 128 bytes occupy the same address space as the SFR. That means they have the same address, but are physically separate from SFR space.

Figure 4. Internal and External Data Memory Address

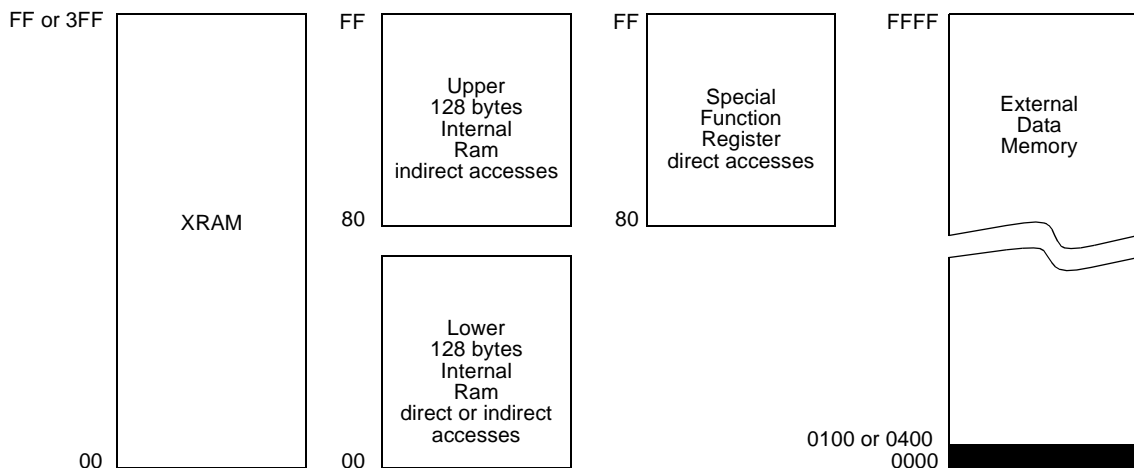

When an instruction accesses an internal location above address 7FH, the CPU knows whether the access is to the upper 128 bytes of data RAM or to SFR space by the addressing mode used in the instruction.

- Instructions that use direct addressing access SFR space. **For example: MOV 0A0H, # data**, accesses the SFR at location 0A0H (which is P2).

- Instructions that use indirect addressing access the Upper 128 bytes of data RAM. **For example: MOV @R0, # data** where R0 contains 0A0H, accesses the data byte at address 0A0H, rather than P2 (whose address is 0A0H).
- The XRAM bytes can be accessed by indirect addressing, with EXTRAM bit cleared and MOVX instructions. This part of memory which is physically located on-chip, logically occupies the first bytes of external data memory. The bits XRS0 and XRS1 are used to hide a part of the available XRAM as explained in Table 7. This can be useful if external peripherals are mapped at addresses already used by the internal XRAM.
- With EXTRAM = 0, the XRAM is indirectly addressed, using the MOVX instruction in combination with any of the registers R0, R1 of the selected bank or DPTR. **An access to XRAM will not affect ports P0, P2, P3.6 (WR) and P3.7 (RD). For example, with EXTRAM = 0, MOVX @R0, # data** where R0 contains 0A0H, accesses the XRAM at address 0A0H rather than external memory. An access to external data memory locations higher than the accessible size of the XRAM will be performed with the MOVX DPTR instructions in the same way as in the standard 80C51, so with P0 and P2 as data/address busses, and P3.6 and P3.7 as write and read timing signals. Accesses to XRAM above 0FFH can only be done thanks to the use of DPTR.
- With EXTRAM = 1, MOVX @Ri and MOVX @DPTR will be similar to the standard 80C51. MOVX @ Ri will provide an eight-bit address multiplexed with data on Port0 and any output port pins can be used to output higher order address bits. This is to provide the external paging capability. MOVX @DPTR will generate a sixteen-bit address. Port2 outputs the high-order eight address bits (the contents of DPH) while Port0 multiplexes the low-order eight address bits (DPL) with data. MOVX @ Ri and MOVX @DPTR will generate either read or write signals on P3.6 (WR) and P3.7 (RD).

The stack pointer (SP) may be located anywhere in the 256 bytes RAM (lower and upper RAM) internal data memory. The stack may not be located in the XRAM.

The M0 bit allows to stretch the XRAM timings; if M0 is set, the read and write pulses are extended from 6 to 30 clock periods. This is useful to access external slow peripherals.

Table 7. Auxiliary Register (08EH)

AUXR Address 08EH	-	-	M0	-	XRS1	XRS0	EXTRA M	AO
Reset value	X	X	0	X	1	0	0	0

Symbol	Function
-	Not implemented, reserved for future use. ⁽¹⁾
AO	Disable/Enable ALE
	AO Operating Mode
	0 ALE is emitted at a constant rate of 1/6 the oscillator frequency (or 1/3 if X2 mode is used)
	1 ALE is active only during a MOVX or MOVC instruction
EXTRAM	Internal/External RAM (00H-FFH) access using MOVX @ Ri/ @ DPTR
	EXTRAM Operating Mode
	0 Internal XRAM access using MOVX @ Ri/ @ DPTR
	1 External data memory access
XRS0 XRS1	XRAM size: Accessible size of the XRAM
	XRS1:0 XRAM size
	0 0 256 bytes
	0 1 512 bytes
	1 0 768 bytes (default)
	1 1 1024 bytes
M0	Stretch MOVX control: the RD/ and the WR/ pulse length is increased according to the value of M0
	M0 Pulse length in clock period
	0 6
	1 30

1. User software should not write 1s to reserved bits. These bits may be used in future 8051 family products to invoke new features. In that case, the reset or inactive value of the new bit will be 0, and its active value will be 1. The value read from a reserved bit is indeterminate.

Timer 2

The timer 2 in the T89C51RD2 is compatible with the timer 2 in the 80C52. It is a 16-bit timer/counter: the count is maintained by two eight-bit timer registers, TH2 and TL2, connected in cascade. It is controlled by T2CON register (See Table 8) and T2MOD register (See Table 9). Timer 2 operation is similar to Timer 0 and Timer 1. $\overline{C/T2}$ selects $F_{OSC}/12$ (timer operation) or external pin T2 (counter operation) as the timer clock input. Setting TR2 allows TL2 to be incremented by the selected input.

Timer 2 has 3 operating modes: capture, autoreload and Baud Rate Generator. These modes are selected by the combination of RCLK, TCLK and CP/RL2 (T2CON), as described in the ATMEL Wireless and Microcontrollers 8-bit Microcontroller Hardware description.

Refer to the ATMEL Wireless and Microcontrollers 8-bit Microcontroller Hardware description for the description of Capture and Baud Rate Generator Modes.

In T89C51RD2 Timer 2 includes the following enhancements:

- Auto-reload mode with up or down counter
- Programmable clock-output

Auto-Reload Mode

The auto-reload mode configures timer 2 as a 16-bit timer or event counter with automatic reload. If DCEN bit in T2MOD is cleared, timer 2 behaves as in 80C52 (refer to the ATMEL Wireless and Microcontrollers 8-bit Microcontroller Hardware description). If DCEN bit is set, timer 2 acts as an Up/down timer/counter as shown in Figure 5. In this mode the T2EX pin controls the direction of count.

When T2EX is high, timer 2 counts up. Timer overflow occurs at FFFFh which sets the TF2 flag and generates an interrupt request. The overflow also causes the 16-bit value in RCAP2H and RCAP2L registers to be loaded into the timer registers TH2 and TL2.

When T2EX is low, timer 2 counts down. Timer underflow occurs when the count in the timer registers TH2 and TL2 equals the value stored in RCAP2H and RCAP2L registers. The underflow sets TF2 flag and reloads FFFFh into the timer registers.

The EXF2 bit toggles when timer 2 overflows or underflows according to the the direction of the count. EXF2 does not generate any interrupt. This bit can be used to provide 17-bit resolution.

Figure 5. Auto-Reload Mode Up/Down Counter (DCEN = 1)

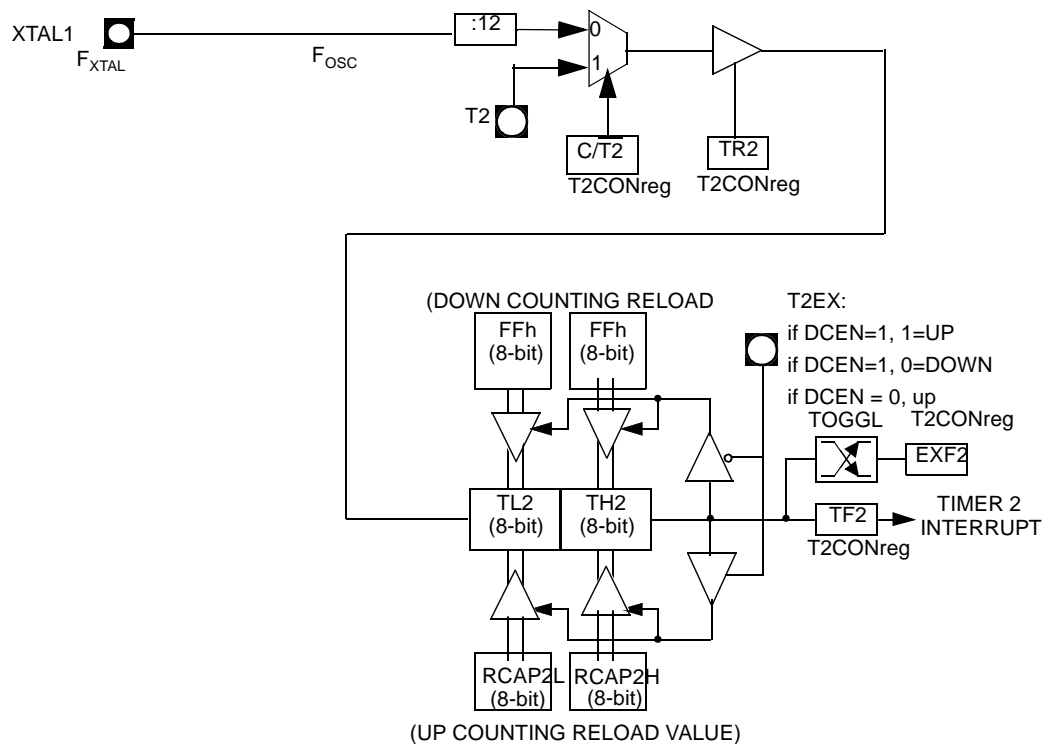

Programmable Clock-Output

In the clock-out mode, timer 2 operates as a 50%-duty-cycle, programmable clock generator (See Figure 6) . The input clock increments TL2 at frequency $F_{OSC}/2$. The timer repeatedly counts to overflow from a loaded value. At overflow, the contents of RCAP2H and RCAP2L registers are loaded into TH2 and TL2. In this mode, timer 2 overflows do not generate interrupts. The formula gives the clock-out frequency as a function of the system oscillator frequency and the value in the RCAP2H and RCAP2L registers :

$$Clock - OutFrequency = \frac{F_{osc}}{4 \times (65536 - RCAP2H/RCAP2L)}$$

For a 16 MHz system clock, timer 2 has a programmable frequency range of 61 Hz ($F_{OSC}/2^{16}$) to 4 MHz ($F_{OSC}/4$). The generated clock signal is brought out to T2 pin (P1.0).

Timer 2 is programmed for the clock-out mode as follows:

- Set T2OE bit in T2MOD register.
- Clear $\overline{C/T2}$ bit in T2CON register.
- Determine the 16-bit reload value from the formula and enter it in RCAP2H/RCAP2L registers.
- Enter a 16-bit initial value in timer registers TH2/TL2. It can be the same as the reload value or a different one depending on the application.
- To start the timer, set TR2 run control bit in T2CON register.

It is possible to use timer 2 as a baud rate generator and a clock generator simultaneously. For this configuration, the baud rates and clock frequencies are not independent since both functions use the values in the RCAP2H and RCAP2L registers.

Figure 6. Clock-Out Mode $C/\overline{T2} = 0$

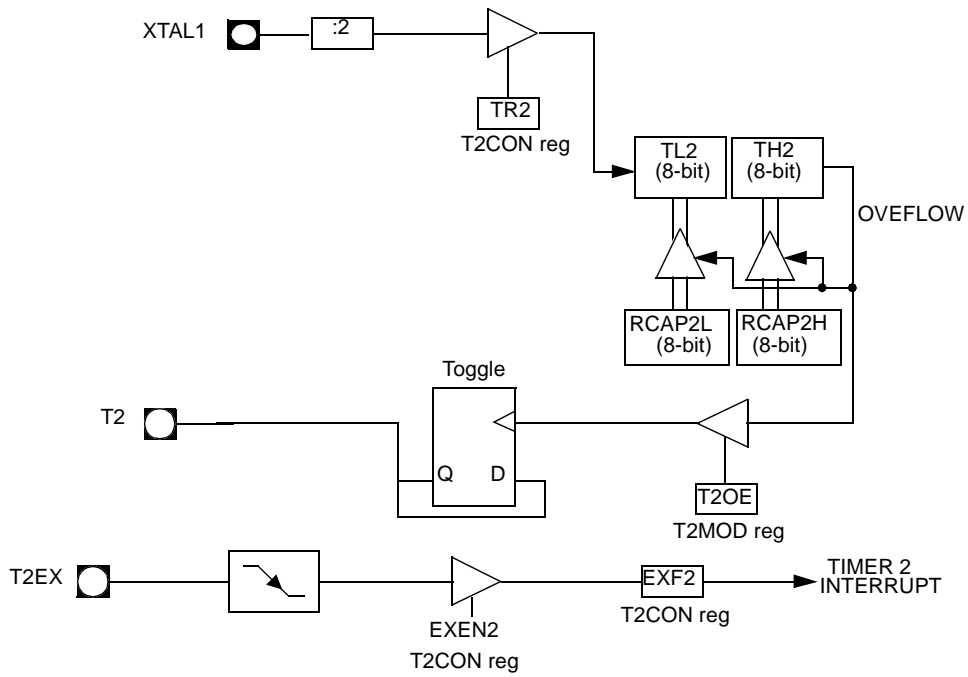

Table 8. T2CON Register
T2CON - Timer 2 Control Register (C8h)

7	6	5	4	3	2	1	0
TF2	EXF2	RCLK	TCLK	EXEN2	TR2	C/T2#	CP/RL2#
Bit Number	Bit Mnemonic	Description					
7	TF2	Timer 2 overflow Flag Must be cleared by software. Set by hardware on timer 2 overflow, if RCLK = 0 and TCLK = 0.					
6	EXF2	Timer 2 External Flag Set when a capture or a reload is caused by a negative transition on T2EX pin if EXEN2=1. When set, causes the CPU to vector to timer 2 interrupt routine when timer 2 interrupt is enabled. Must be cleared by software. EXF2 doesn't cause an interrupt in Up/down counter mode (DCEN = 1)					
5	RCLK	Receive Clock bit Clear to use timer 1 overflow as receive clock for serial port in mode 1 or 3. Set to use timer 2 overflow as receive clock for serial port in mode 1 or 3.					
4	TCLK	Transmit Clock bit Clear to use timer 1 overflow as transmit clock for serial port in mode 1 or 3. Set to use timer 2 overflow as transmit clock for serial port in mode 1 or 3.					
3	EXEN2	Timer 2 External Enable bit Clear to ignore events on T2EX pin for timer 2 operation. Set to cause a capture or reload when a negative transition on T2EX pin is detected, if timer 2 is not used to clock the serial port.					
2	TR2	Timer 2 Run control bit Clear to turn off timer 2. Set to turn on timer 2.					
1	C/T2#	Timer/Counter 2 select bit Clear for timer operation (input from internal clock system: F _{OSC}). Set for counter operation (input from T2 input pin, falling edge trigger). Must be 0 for clock out mode.					
0	CP/RL2#	Timer 2 Capture/Reload bit If RCLK=1 or TCLK=1, CP/RL2# is ignored and timer is forced to auto-reload on timer 2 overflow. Clear to auto-reload on timer 2 overflows or negative transitions on T2EX pin if EXEN2=1. Set to capture on negative transitions on T2EX pin if EXEN2=1.					

Reset Value = 0000 0000b

Bit addressable

Table 9. T2MOD Register
T2MOD - Timer 2 Mode Control Register (C9h)

7	6	5	4	3	2	1	0
-	-	-	-	-	-	T2OE	DCEN

Bit Number	Bit Mnemonic	Description
7	-	Reserved The value read from this bit is indeterminate. Do not set this bit.
6	-	Reserved The value read from this bit is indeterminate. Do not set this bit.
5	-	Reserved The value read from this bit is indeterminate. Do not set this bit.
4	-	Reserved The value read from this bit is indeterminate. Do not set this bit.
3	-	Reserved The value read from this bit is indeterminate. Do not set this bit.
2	-	Reserved The value read from this bit is indeterminate. Do not set this bit.
1	T2OE	Timer 2 Output Enable bit Clear to program P1.0/T2 as clock input or I/O port. Set to program P1.0/T2 as clock output.
0	DCEN	Down Counter Enable bit Clear to disable timer 2 as up/down counter. Set to enable timer 2 as up/down counter.

Reset Value = XXXX XX00b
Not bit addressable

Programmable Counter Array PCA

The PCA provides more timing capabilities with less CPU intervention than the standard timer/counters. Its advantages include reduced software overhead and improved accuracy. The PCA consists of a dedicated timer/counter which serves as the time base for an array of five compare/ capture modules. Its clock input can be programmed to count any one of the following signals:

- Oscillator frequency ÷ 12 (÷ 6 in X2 mode)
- Oscillator frequency ÷ 4 (÷ 2 in X2 mode)
- Timer 0 overflow
- External input on ECI (P1.2)

Each compare/capture modules can be programmed in any one of the following modes:

- rising and/or falling edge capture,
- software timer,
- high-speed output, or
- pulse width modulator.

Module 4 can also be programmed as a watchdog timer (See Section "PCA Watchdog Timer", page 32).

When the compare/capture modules are programmed in the capture mode, software timer, or high speed output mode, an interrupt can be generated when the module executes its function. All five modules plus the PCA timer overflow share one interrupt vector.

The PCA timer/counter and compare/capture modules share Port 1 for external I/O. These pins are listed below. If one or several bits in the port are not used for the PCA, they can still be used for standard I/O.

PCA component	External I/O Pin
16-bit Counter	P1.2 / ECI
16-bit Module 0	P1.3 / CEX0
16-bit Module 1	P1.4 / CEX1
16-bit Module 2	P1.5 / CEX2
16-bit Module 3	P1.6 / CEX3
16-bit Module 4	P1.7 / CEX4

The PCA timer is a common time base for all five modules (See Figure 7). The timer count source is determined from the CPS1 and CPS0 bits in the **CMOD SFR** (See Table 10) and can be programmed to run at:

- 1/12 the oscillator frequency. (Or 1/6 in X2 Mode)
- 1/4 the oscillator frequency. (Or 1/2 in X2 Mode)
- The Timer 0 overflow
- The input on the ECI pin (P1.2)

Figure 7. PCA Timer/Counter

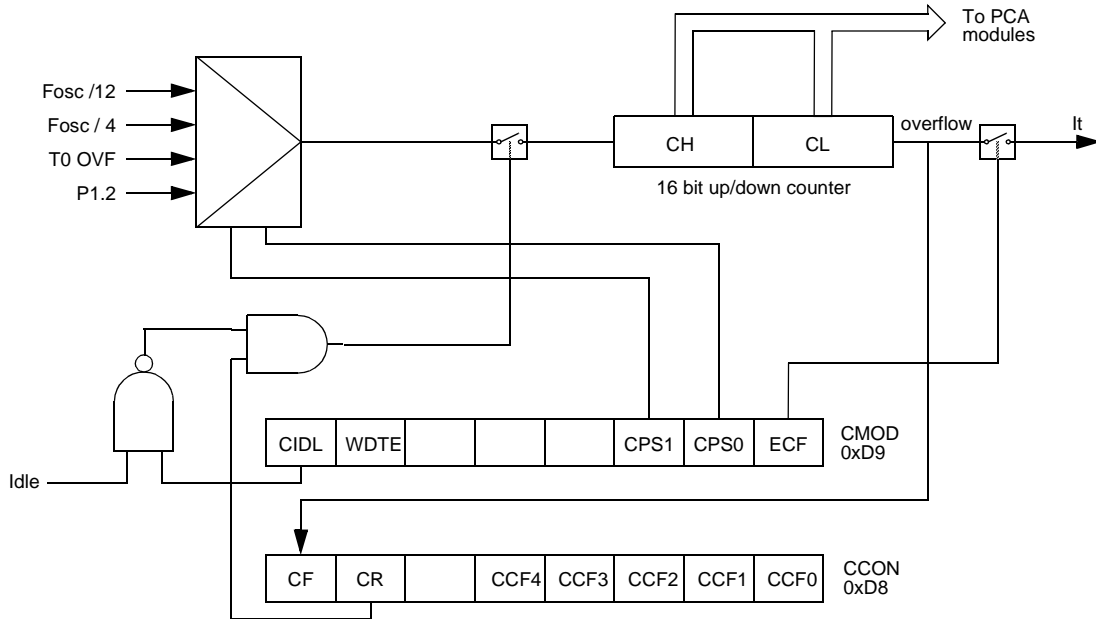

Table 10. CMOD: PCA Counter Mode Register

CMOD Address 0D9H		CIDL	WDTE	-	-	-	CPS1	CPS0	ECF
Reset value		0	0	X	X	X	0	0	0

Symbol	Function		
CIDL	Counter Idle control: CIDL = 0 programs the PCA Counter to continue functioning during idle Mode. CIDL = 1 programs it to be gated off during idle.		
WDTE	Watchdog Timer Enable: WDTE = 0 disables Watchdog Timer function on PCA Module 4. WDTE = 1 enables it.		
-	Not implemented, reserved for future use. ⁽¹⁾		
CPS1	PCA Count Pulse Select bit 1.		
CPS0	PCA Count Pulse Select bit 0.		
	CPS1	CPS0	Selected PCA input. ⁽²⁾
	0	0	Internal clock $f_{osc}/12$ (Or $f_{osc}/6$ in X2 Mode).
	0	1	Internal clock $f_{osc}/4$ (Or $f_{osc}/2$ in X2 Mode).
	1	0	Timer 0 Overflow
	1	1	External clock at ECI/P1.2 pin (max rate = $f_{osc}/8$)
ECF	PCA Enable Counter Overflow interrupt: ECF = 1 enables CF bit in CCON to generate an interrupt. ECF = 0 disables that function of CF.		

1. User software should not write 1s to reserved bits. These bits may be used in future 8051 family products to invoke new features. In that case, the reset or inactive value of the new bit will be 0, and its active value will be 1. The value read from a reserved bit is indeterminate.
2. f_{osc} = oscillator frequency

The **CMOD SFR** includes three additional bits associated with the PCA (See Figure 7 and Table 10).

- The CIDL bit which allows the PCA to stop during idle mode.
- The WDTE bit which enables or disables the watchdog function on module 4.
- The ECF bit which when set causes an interrupt and the PCA overflow flag CF (in the CCON SFR) to be set when the PCA timer overflows.

The **CCON SFR** contains the run control bit for the PCA and the flags for the PCA timer (CF) and each module (Refer to Table 11).

- Bit CR (CCON.6) must be set by software to run the PCA. The PCA is shut off by clearing this bit.
- Bit CF: The CF bit (CCON.7) is set when the PCA counter overflows and an interrupt will be generated if the ECF bit in the CMOD register is set. The CF bit can only be cleared by software.
- Bits 0 through 4 are the flags for the modules (bit 0 for module 0, bit 1 for module 1, etc.) and are set by hardware when either a match or a capture occurs. These flags also can only be cleared by software.

Table 11. CCON: PCA Counter Control Register

CCON Address 0D8H		CF	CR	-	CCF4	CCF3	CCF2	CCF1	CCF0
Reset value		0	0	X	0	0	0	0	0

Symbol	Function
CF	PCA Counter Overflow flag. Set by hardware when the counter rolls over. CF flags an interrupt if bit ECF in CMOD is set. CF may be set by either hardware or software but can only be cleared by software.
CR	PCA Counter Run control bit. Set by software to turn the PCA counter on. Must be cleared by software to turn the PCA counter off.
-	Not implemented, reserved for future use. ⁽¹⁾
CCF4	PCA Module 4 interrupt flag. Set by hardware when a match or capture occurs. Must be cleared by software.
CCF3	PCA Module 3 interrupt flag. Set by hardware when a match or capture occurs. Must be cleared by software.
CCF2	PCA Module 2 interrupt flag. Set by hardware when a match or capture occurs. Must be cleared by software.
CCF1	PCA Module 1 interrupt flag. Set by hardware when a match or capture occurs. Must be cleared by software.
CCF0	PCA Module 0 interrupt flag. Set by hardware when a match or capture occurs. Must be cleared by software.

1. User software should not write 1s to reserved bits. These bits may be used in future 8051 family products to invoke new features. In that case, the reset or inactive value of the new bit will be 0, and its active value will be 1. The value read from a reserved bit is indeterminate.

The **watchdog timer** function is implemented in module 4 (See Figure 10).



The PCA interrupt system is shown in Figure 8.

Figure 8. PCA Interrupt System

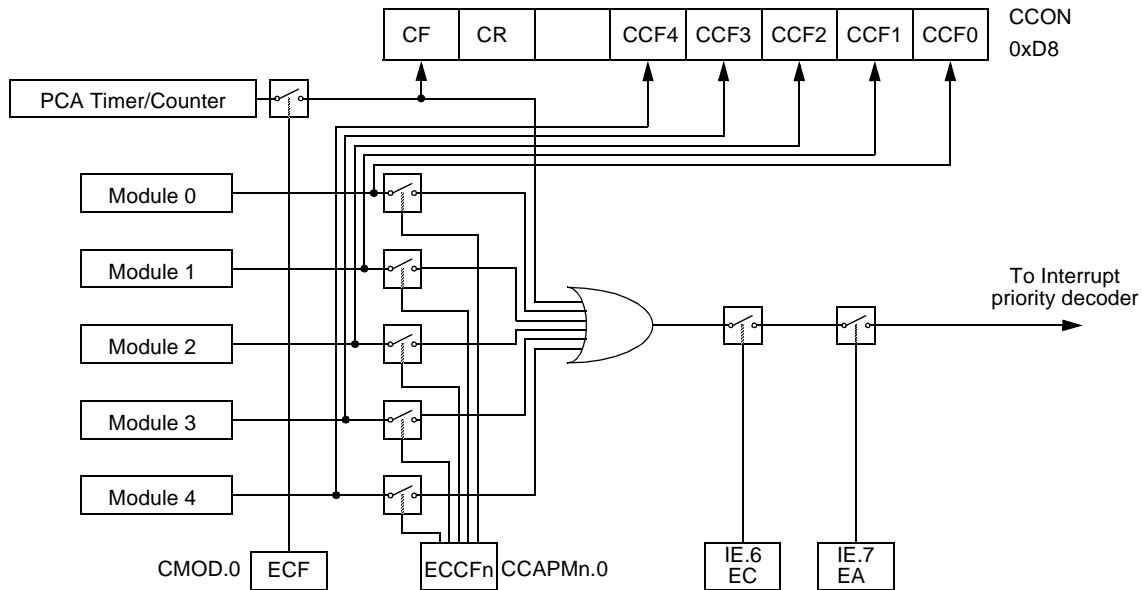

PCA Modules: each one of the five compare/capture modules has six possible functions. It can perform:

- 16-bit Capture, positive-edge triggered,
- 16-bit Capture, negative-edge triggered,
- 16-bit Capture, both positive and negative-edge triggered,
- 16-bit Software Timer,
- 16-bit High Speed Output,
- 8-bit Pulse Width Modulator.

In addition, module 4 can be used as a Watchdog Timer.

Each module in the PCA has a special function register associated with it. These registers are: CCAPM0 for module 0, CCAPM1 for module 1, etc. (See Table 12). The registers contain the bits that control the mode that each module will operate in.

- The ECCF bit (CCAPMn.0 where n=0, 1, 2, 3, or 4 depending on the module) enables the CCF flag in the CCON SFR to generate an interrupt when a match or compare occurs in the associated module.
- PWM (CCAPMn.1) enables the pulse width modulation mode.
- The TOG bit (CCAPMn.2) when set causes the CEX output associated with the module to toggle when there is a match between the PCA counter and the module's capture/compare register.
- The match bit MAT (CCAPMn.3) when set will cause the CCFn bit in the CCON register to be set when there is a match between the PCA counter and the module's capture/compare register.
- The next two bits CAPN (CCAPMn.4) and CAPP (CCAPMn.5) determine the edge that a capture input will be active on. The CAPN bit enables the negative edge, and the CAPP bit enables the positive edge. If both bits are set both edges will be enabled and a capture will occur for either transition.

- The last bit in the register ECOM (CCAPMn.6) when set enables the comparator function.

Table 13 shows the CCAPMn settings for the various PCA functions.

Table 12. CCAPMn: PCA Modules Compare/Capture Control Registers

CCAPMn
Address
n = 0 - 4

CCAPM0=0DAH
CCAPM1=0DBH
CCAPM2=0DCH
CCAPM3=0DDH
CCAPM4=0DEH

	-	ECO Mn	CAPP n	CAPN n	MATn	TOGn	PWM m	ECCF n
Reset value	X	0	0	0	0	0	0	0

Symbol	Function
-	Not implemented, reserved for future use. ⁽¹⁾
ECOMn	Enable Comparator. ECOMn = 1 enables the comparator function.
CAPPn	Capture Positive, CAPPn = 1 enables positive edge capture.
CAPNn	Capture Negative, CAPNn = 1 enables negative edge capture.
MATn	Match. When MATn = 1, a match of the PCA counter with this module's compare/capture register causes the CCFn bit in CCON to be set, flagging an interrupt.
TOGn	Toggle. When TOGn = 1, a match of the PCA counter with this module's compare/capture register causes the CEXn pin to toggle.
PWMn	Pulse Width Modulation Mode. PWMn = 1 enables the CEXn pin to be used as a pulse width modulated output.
ECCFn	Enable CCF interrupt. Enables compare/capture flag CCFn in the CCON register to generate an interrupt.

- User software should not write 1s to reserved bits. These bits may be used in future 8051 family products to invoke new features. In that case, the reset or inactive value of the new bit will be 0, and its active value will be 1. The value read from a reserved bit is indeterminate.

Table 13. PCA Module Modes (CCAPMn Registers)

ECOMn	CAPPn	CAPNn	MATn	TOGn	PWMm	ECCFn	Module Function
0	0	0	0	0	0	0	No Operation
X	1	0	0	0	0	X	16-bit capture by a positive-edge trigger on CEXn
X	0	1	0	0	0	X	16-bit capture by a negative trigger on CEXn
X	1	1	0	0	0	X	16-bit capture by a transition on CEXn
1	0	0	1	0	0	X	16-bit Software Timer / Compare mode.
1	0	0	1	1	0	X	16-bit High Speed Output
1	0	0	0	0	1	0	8-bit PWM

ECOMn	CAPPn	CAPNn	MATn	TOGn	PWMm	ECCFn	Module Function
1	0	0	1	X	0	X	Watchdog Timer (module 4 only)

There are two additional registers associated with each of the PCA modules. They are CCAPnH and CCAPnL and these are the registers that store the 16-bit count when a capture occurs or a compare should occur. When a module is used in the PWM mode these registers are used to control the duty cycle of the output (See Table 14 & Table 15)

Table 14. CCAPnH: PCA Modules Capture/Compare Registers High

CCAPnH
Address
n = 0 - 4

CCAP0H=0FAH
CCAP1H=0FBH
CCAP2H=0FCH
CCAP3H=0FDH
CCAP4H=0FEH

	7	6	5	4	3	2	1	0
Reset value	0	0	0	0	0	0	0	0

Table 15. CCAPnL: PCA Modules Capture/Compare Registers Low

CCAPnL
Address
n = 0 - 4

CCAP0L=0EAH
CCAP1L=0EBH
CCAP2L=0ECH
CCAP3L=0EDH
CCAP4L=0EEH

	7	6	5	4	3	2	1	0
Reset value	0	0	0	0	0	0	0	0

Table 16. CH: PCA Counter High

CH
Address 0F9H

	7	6	5	4	3	2	1	0
Reset value	0	0	0	0	0	0	0	0

Table 17. CL: PCA Counter Low

CL
Address 0E9H

	7	6	5	4	3	2	1	0
Reset value	0	0	0	0	0	0	0	0

PCA Capture Mode

To use one of the PCA modules in the capture mode either one or both of the CCAPM bits CAPN and CAPP for that module must be set. The external CEX input for the module (on port 1) is sampled for a transition. When a valid transition occurs the PCA hardware loads the value of the PCA counter registers (CH and CL) into the module's capture registers (CCAPnL and CCAPnH). If the CCFn bit for the module in the CCON-SFR and the ECCFn bit in the CCAPMn SFR are set then an interrupt will be generated (Refer to Figure 9).

Figure 9. PCA Capture Mode

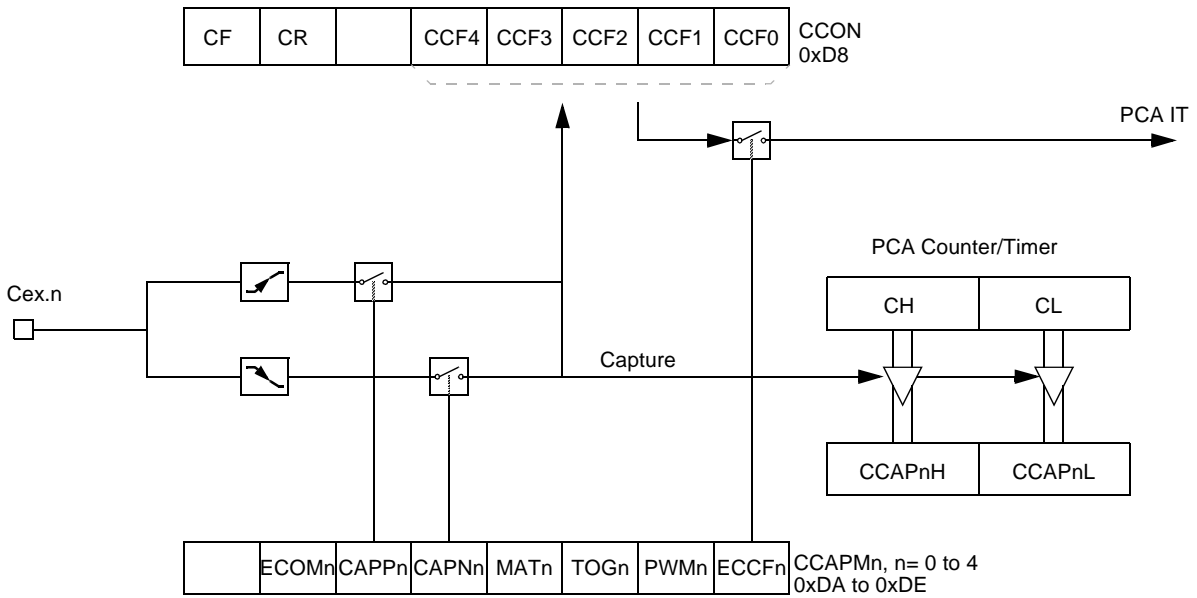

16-bit Software Timer/ Compare Mode

The PCA modules can be used as software timers by setting both the $ECOM$ and MAT bits in the modules $CCAPM_n$ register. The PCA timer will be compared to the module's capture registers and when a match occurs an interrupt will occur if the $CCFn$ ($CCON$ SFR) and the $ECCFn$ ($CCAPM_n$ SFR) bits for the module are both set (See Figure 10).

Figure 10. PCA Compare Mode and PCA Watchdog Timer

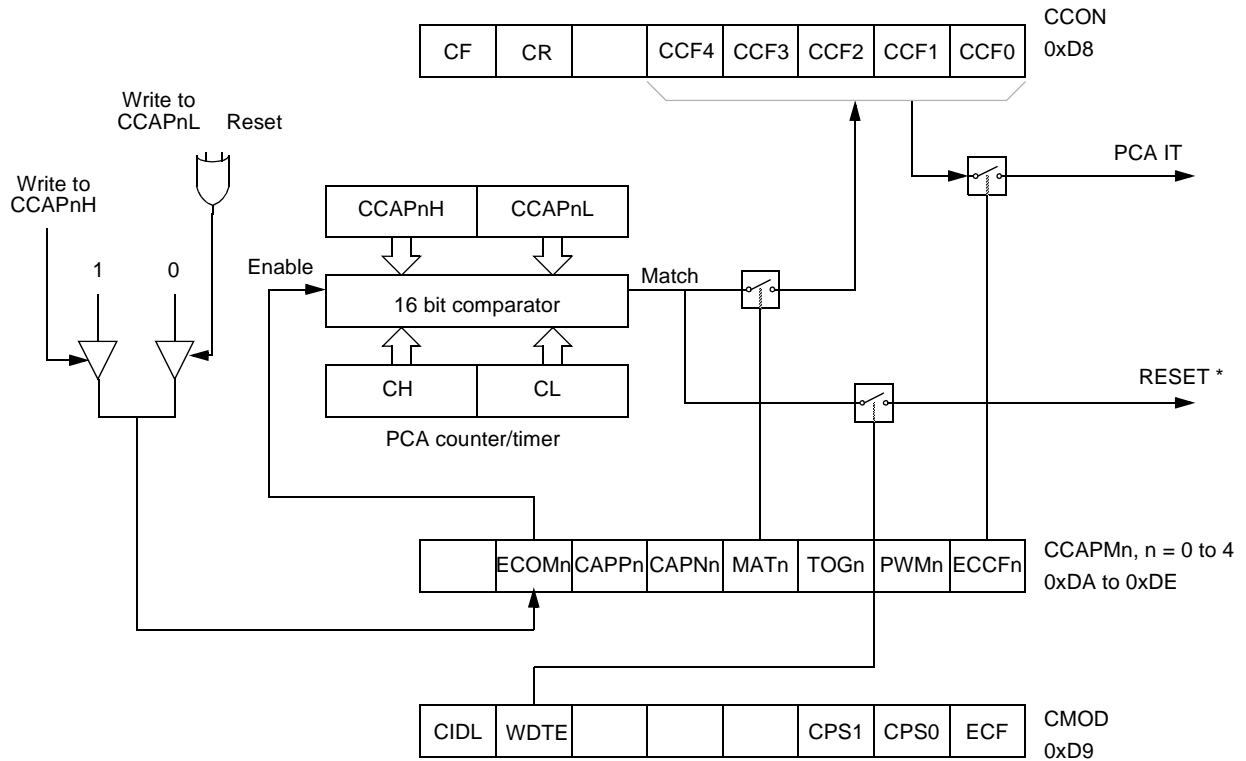

* Only for Module 4

Before enabling ECOM bit, CCAPnL and CCAPnH should be set with a non zero value, otherwise an unwanted match could happen. Writing to CCAPnH will set the ECOM bit.

Once ECOM set, writing CCAPnL will clear ECOM so that an unwanted match doesn't occur while modifying the compare value. Writing to CCAPnH will set ECOM. For this reason, user software should write CCAPnL first, and then CCAPnH. Of course, the ECOM bit can still be controlled by accessing to CCAPMn register.

High Speed Output Mode

In this mode the CEX output (on port 1) associated with the PCA module will toggle each time a match occurs between the PCA counter and the module's capture registers. To activate this mode the TOG, MAT, and ECOM bits in the module's CCAPMn SFR must be set (See Figure 11).

A prior write must be done to CCAPnL and CCAPnH before writing the ECOMn bit.

Figure 11. PCA High Speed Output Mode

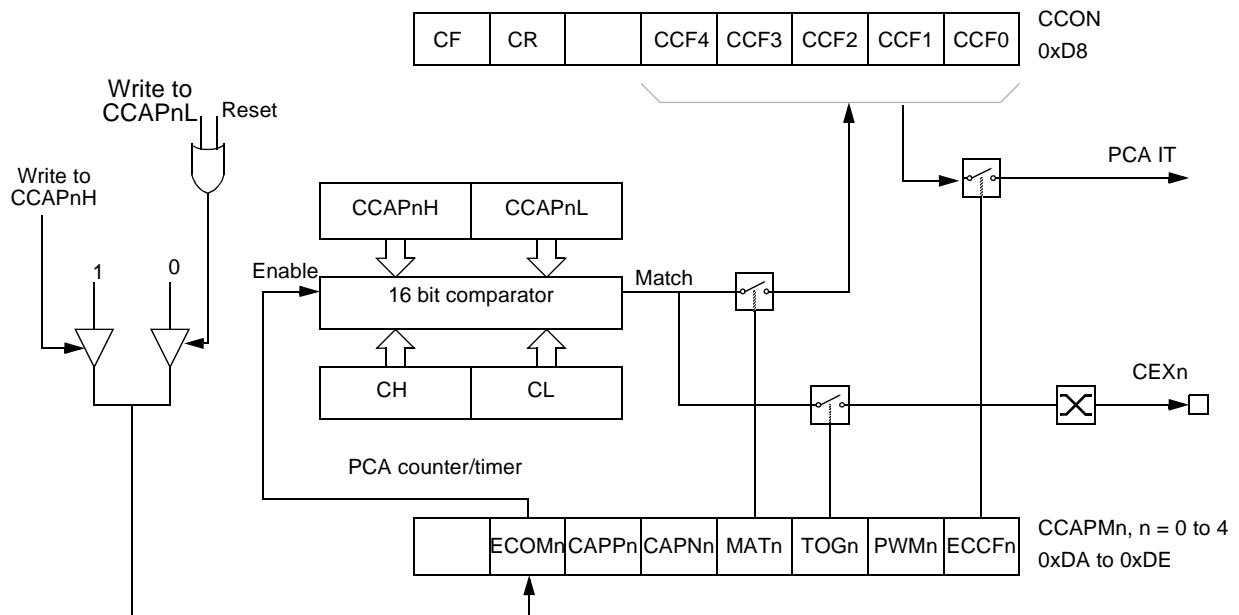

Before enabling ECOM bit, CCAPnL and CCAPnH should be set with a non zero value, otherwise an unwanted match could happen.

Once ECOM set, writing CCAPnL will clear ECOM so that an unwanted match doesn't occur while modifying the compare value. Writing to CCAPnH will set ECOM. For this reason, user software should write CCAPnL first, and then CCAPnH. Of course, the ECOM bit can still be controlled by accessing to CCAPMn register.

Pulse Width Modulator Mode

All of the PCA modules can be used as PWM outputs. Figure 12 shows the PWM function. The frequency of the output depends on the source for the PCA timer. All of the modules will have the same frequency of output because they all share the PCA timer. The duty cycle of each module is independently variable using the module's capture register CCAPL_n. When the value of the PCA CL SFR is less than the value in the module's CCAPL_n SFR the output will be low, when it is equal to or greater than the output will be high. When CL overflows from FF to 00, CCAPL_n is reloaded with the value in CCAPH_n. This allows updating the PWM without glitches. The PWM and ECOM bits in the module's CCAPM_n register must be set to enable the PWM mode.

Figure 12. PCA PWM Mode

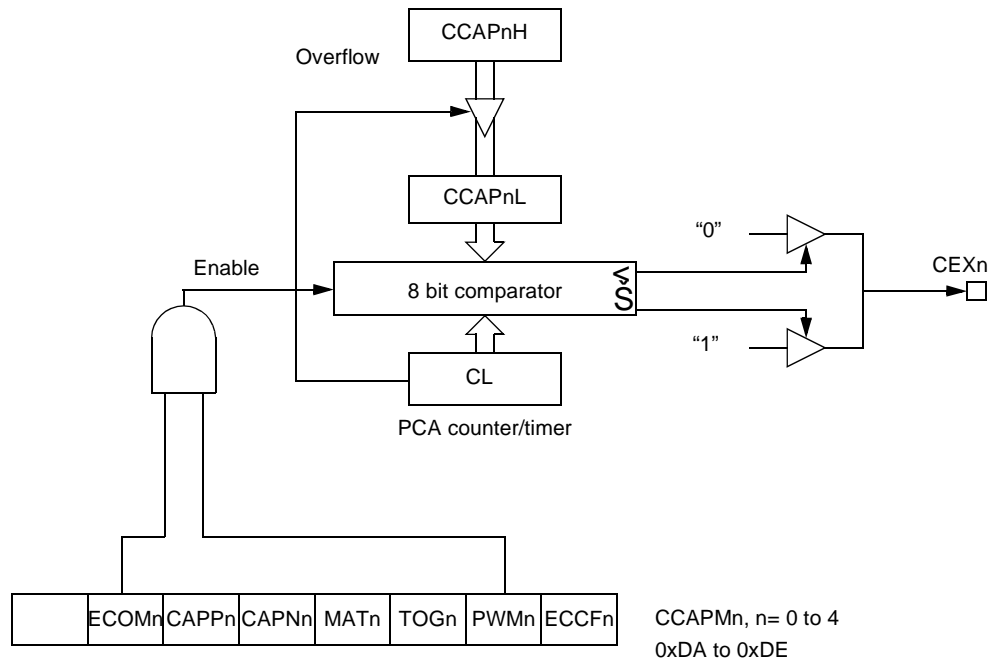

PCA Watchdog Timer

An on-board watchdog timer is available with the PCA to improve the reliability of the system without increasing chip count. Watchdog timers are useful for systems that are susceptible to noise, power glitches, or electrostatic discharge. Module 4 is the only PCA module that can be programmed as a watchdog. However, this module can still be used for other modes if the watchdog is not needed. Figure 10 shows a diagram of how the watchdog works. The user pre-loads a 16-bit value in the compare registers. Just like the other compare modes, this 16-bit value is compared to the PCA timer value. If a match is allowed to occur, an internal reset will be generated. This will not cause the RST pin to be driven high.

In order to hold off the reset, the user has three options:

- 1. periodically change the compare value so it will never match the PCA timer,
- 2. periodically change the PCA timer value so it will never match the compare values, or
- 3. disable the watchdog by clearing the WDTE bit before a match occurs and then re-enable it.

The first two options are more reliable because the watchdog timer is never disabled as in option #3. If the program counter ever goes astray, a match will eventually occur and cause an internal reset. The second option is also not recommended if other PCA modules are being used. Remember, the PCA timer is the time base for all modules; changing the time base for other modules would not be a good idea. Thus, in most applications the first solution is the best option.

This watchdog timer won't generate a reset out on the reset pin.

Serial I/O Port

The serial I/O port in the T89C51RD2 is compatible with the serial I/O port in the 80C52. It provides both synchronous and asynchronous communication modes. It operates as an Universal Asynchronous Receiver and Transmitter (UART) in three full-duplex modes (Modes 1, 2 and 3). Asynchronous transmission and reception can occur simultaneously and at different baud rates

Serial I/O port includes the following enhancements:

- Framing error detection
- Automatic address recognition

Framing Error Detection

Framing bit error detection is provided for the three asynchronous modes (modes 1, 2 and 3). To enable the framing bit error detection feature, set SMOD0 bit in PCON register (See Figure 13).

Figure 13. Framing Error Block Diagram

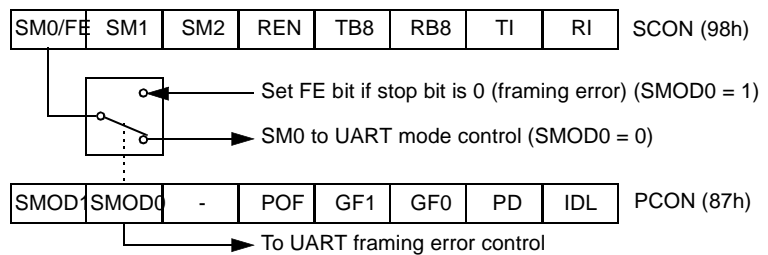

When this feature is enabled, the receiver checks each incoming data frame for a valid stop bit. An invalid stop bit may result from noise on the serial lines or from simultaneous transmission by two CPUs. If a valid stop bit is not found, the Framing Error bit (FE) in SCON register (See Table 20.) bit is set.

Software may examine FE bit after each reception to check for data errors. Once set, only software or a reset can clear FE bit. Subsequently received frames with valid stop bits cannot clear FE bit. When FE feature is enabled, RI rises on stop bit instead of the last data bit (See Figure 14. and Figure 15.).

Figure 14. UART Timings in Mode 1

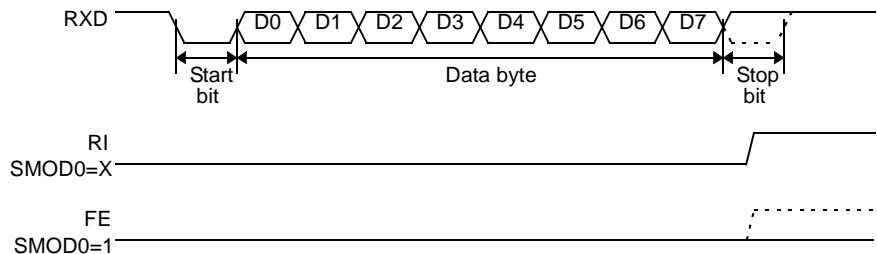
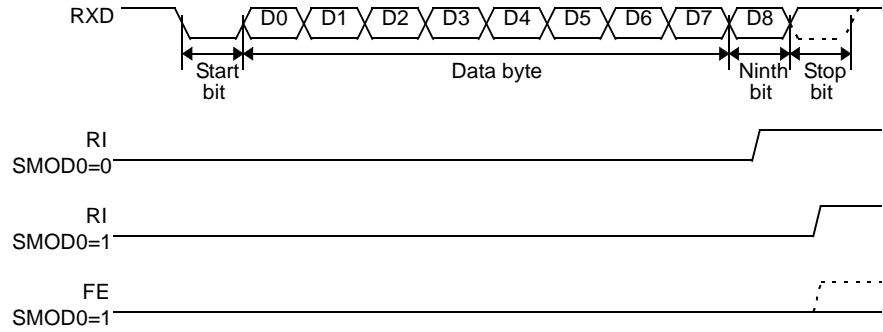

Figure 15. UART Timings in Modes 2 and 3



Automatic Address Recognition

The automatic address recognition feature is enabled when the multiprocessor communication feature is enabled (SM2 bit in SCON register is set).

Implemented in hardware, automatic address recognition enhances the multiprocessor communication feature by allowing the serial port to examine the address of each incoming command frame. Only when the serial port recognizes its own address, the receiver sets RI bit in SCON register to generate an interrupt. This ensures that the CPU is not interrupted by command frames addressed to other devices.

If desired, you may enable the automatic address recognition feature in mode 1. In this configuration, the stop bit takes the place of the ninth data bit. Bit RI is set only when the received command frame address matches the device's address and is terminated by a valid stop bit.

To support automatic address recognition, a device is identified by a given address and a broadcast address.

Note: The multiprocessor communication and automatic address recognition features cannot be enabled in mode 0 (i.e. setting SM2 bit in SCON register in mode 0 has no effect).

Given Address

Each device has an individual address that is specified in SADDR register; the SADEN register is a mask byte that contains don't-care bits (defined by zeros) to form the device's given address. The don't-care bits provide the flexibility to address one or more slaves at a time. The following example illustrates how a given address is formed.

To address a device by its individual address, the SADEN mask byte must be 1111 1111b.

For example:

```
SADDR0101 0110b
SADEN1111 1100b
Given0101 01XXb
```

The following is an example of how to use given addresses to address different slaves:

```
Slave A:SADDR1111 0001b
SADEN1111 1010b
Given1111 0X0Xb
```

```
Slave B:SADDR1111 0011b
SADEN1111 1001b
Given1111 0XX1b
```

```
Slave C:SADDR1111 0010b
SADEN1111 1101b
Given1111 00X1b
```

The SADEN byte is selected so that each slave may be addressed separately. For slave A, bit 0 (the LSB) is a don't-care bit; for slaves B and C, bit 0 is a 1. To communicate with slave A only, the master must send an address where bit 0 is clear (e.g. 1111 0000b).

For slave A, bit 1 is a 1; for slaves B and C, bit 1 is a don't care bit. To communicate with slaves B and C, but not slave A, the master must send an address with bits 0 and 1 both set (e.g. 1111 0011b).

To communicate with slaves A, B and C, the master must send an address with bit 0 set, bit 1 clear, and bit 2 clear (e.g. 1111 0001b).

Broadcast Address

A broadcast address is formed from the logical OR of the SADDR and SADEN registers with zeros defined as don't-care bits, e.g.:

```
SADDR 0101 0110b
SADEN 1111 1100b
Broadcast =SADDR OR SADEN1111 111Xb
```

The use of don't-care bits provides flexibility in defining the broadcast address, however in most applications, a broadcast address is FFh. The following is an example of using broadcast addresses:

```
Slave A:SADDR1111 0001b
      SADEN1111 1010b
Broadcast1111 1X11b,
```

```
Slave B:SADDR1111 0011b
      SADEN1111 1001b
Broadcast1111 1X11B,
```

```
Slave C:SADDR=1111 0010b
      SADEN1111 1101b
Broadcast1111 1111b
```

For slaves A and B, bit 2 is a don't care bit; for slave C, bit 2 is set. To communicate with all of the slaves, the master must send an address FFh. To communicate with slaves A and B, but not slave C, the master can send an address FBh.

Reset Addresses

On reset, the SADDR and SADEN registers are initialized to 00h, i.e. the given and broadcast addresses are XXXX XXXXb (all don't-care bits). This ensures that the serial port will reply to any address, and so, that it is backwards compatible with the 80C51 microcontrollers that do not support automatic address recognition.

Table 18. SADEN - Slave Address Mask Register (B9h)

7	6	5	4	3	2	1	0

Reset Value = 0000 0000b
Not bit addressable

Table 19. SADDR - Slave Address Register (A9h)

7	6	5	4	3	2	1	0

Reset Value = 0000 0000b

Not bit addressable

Table 20. SCON Register
SCON - Serial Control Register (98h)

7	6	5	4	3	2	1	0
FE/SM0	SM1	SM2	REN	TB8	RB8	TI	RI

Bit Number	Bit Mnemonic	Description																									
7	FE	Framing Error bit (SMOD0=1) Clear to reset the error state, not cleared by a valid stop bit. Set by hardware when an invalid stop bit is detected. SMOD0 must be set to enable access to the FE bit																									
	SM0	Serial port Mode bit 0 Refer to SM1 for serial port mode selection. SMOD0 must be cleared to enable access to the SM0 bit																									
6	SM1	Serial port Mode bit 1 <table border="1" style="font-size: small; width: 100%;"> <thead> <tr> <th>SM0</th> <th>SM1</th> <th>Mode</th> <th>Description</th> <th>Baud Rate</th> </tr> </thead> <tbody> <tr> <td>0</td> <td>0</td> <td>0</td> <td>Shift Register</td> <td>$F_{XTAL}/12$ (/6 in X2 mode)</td> </tr> <tr> <td>0</td> <td>1</td> <td>1</td> <td>8-bit UART</td> <td>Variable</td> </tr> <tr> <td>1</td> <td>0</td> <td>2</td> <td>9-bit UART</td> <td>$F_{XTAL}/64$ or $F_{XTAL}/32$ (/32 or 16 in X2 mode)</td> </tr> <tr> <td>1</td> <td>1</td> <td>3</td> <td>9-bit UART</td> <td>Variable</td> </tr> </tbody> </table>	SM0	SM1	Mode	Description	Baud Rate	0	0	0	Shift Register	$F_{XTAL}/12$ (/6 in X2 mode)	0	1	1	8-bit UART	Variable	1	0	2	9-bit UART	$F_{XTAL}/64$ or $F_{XTAL}/32$ (/32 or 16 in X2 mode)	1	1	3	9-bit UART	Variable
SM0	SM1	Mode	Description	Baud Rate																							
0	0	0	Shift Register	$F_{XTAL}/12$ (/6 in X2 mode)																							
0	1	1	8-bit UART	Variable																							
1	0	2	9-bit UART	$F_{XTAL}/64$ or $F_{XTAL}/32$ (/32 or 16 in X2 mode)																							
1	1	3	9-bit UART	Variable																							
5	SM2	Serial port Mode 2 bit / Multiprocessor Communication Enable bit Clear to disable multiprocessor communication feature. Set to enable multiprocessor communication feature in mode 2 and 3, and eventually mode 1. This bit should be cleared in mode 0.																									
4	REN	Reception Enable bit Clear to disable serial reception. Set to enable serial reception.																									
3	TB8	Transmitter Bit 8 / Ninth bit to transmit in modes 2 and 3. Clear to transmit a logic 0 in the 9th bit. Set to transmit a logic 1 in the 9th bit.																									
2	RB8	Receiver Bit 8 / Ninth bit received in modes 2 and 3 Cleared by hardware if 9th bit received is a logic 0. Set by hardware if 9th bit received is a logic 1. In mode 1, if SM2 = 0, RB8 is the received stop bit. In mode 0 RB8 is not used.																									
1	TI	Transmit Interrupt flag Clear to acknowledge interrupt. Set by hardware at the end of the 8th bit time in mode 0 or at the beginning of the stop bit in the other modes.																									
0	RI	Receive Interrupt flag Clear to acknowledge interrupt. Set by hardware at the end of the 8th bit time in mode 0, see Figure 14. and Figure 15. in the other modes.																									

Reset Value = 0000 0000b

Bit addressable

Table 21. PCON Register
PCON - Power Control Register (87h)

7	6	5	4	3	2	1	0
SMOD1	SMOD0	-	POF	GF1	GF0	PD	IDL
Bit Number	Bit Mnemonic	Description					
7	SMOD1	Serial port Mode bit 1 Set to select double baud rate in mode 1, 2 or 3.					
6	SMOD0	Serial port Mode bit 0 Clear to select SM0 bit in SCON register. Set to to select FE bit in SCON register.					
5	-	Reserved The value read from this bit is indeterminate. Do not set this bit.					
4	POF	Power-Off Flag Clear to recognize next reset type. Set by hardware when VCC rises from 0 to its nominal voltage. Can also be set by software.					
3	GF1	General purpose Flag Cleared by user for general purpose usage. Set by user for general purpose usage.					
2	GF0	General purpose Flag Cleared by user for general purpose usage. Set by user for general purpose usage.					
1	PD	Power-Down mode bit Cleared by hardware when reset occurs. Set to enter power-down mode.					
0	IDL	Idle mode bit Clear by hardware when interrupt or reset occurs. Set to enter idle mode.					

Reset Value = 00X1 0000b

Not bit addressable

Power-off flag reset value will be 1 only after a power on (cold reset). A warm reset doesn't affect the value of this bit.

Interrupt System

The T89C51RD2 has a total of 7 interrupt vectors: two external interrupts ($\overline{INT0}$ and $INT1$), three timer interrupts (timers 0, 1 and 2), the serial port interrupt and the PCA global interrupt. These interrupts are shown in Figure 16.

Figure 16. Interrupt Control System

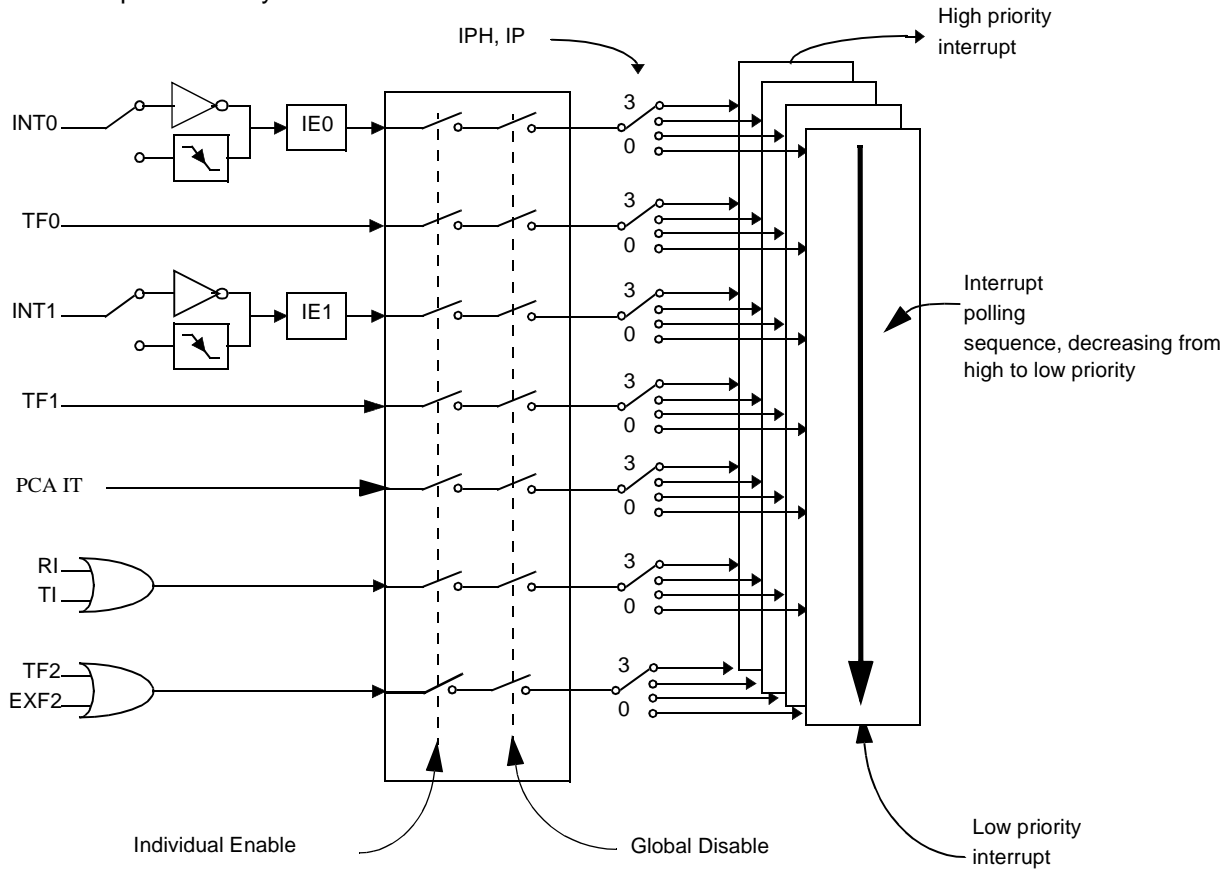

Each of the interrupt sources can be individually enabled or disabled by setting or clearing a bit in the Interrupt Enable register (See Table 23.). This register also contains a global disable bit, which must be cleared to disable all interrupts at once.

Each interrupt source can also be individually programmed to one out of four priority levels by setting or clearing a bit in the Interrupt Priority register (See Table 24.) and in the Interrupt Priority High register (See Table 22). shows the bit values and priority levels associated with each combination.

Table 22. Priority Level Bit Values

IPH.x	IP.x	Interrupt Level Priority
0	0	0 (Lowest)
0	1	1
1	0	2
1	1	3 (Highest)

A low-priority interrupt can be interrupted by a high priority interrupt, but not by another low-priority interrupt. A high-priority interrupt can't be interrupted by any other interrupt source.

If two interrupt requests of different priority levels are received simultaneously, the request of higher priority level is serviced. If interrupt requests of the same priority level are received simultaneously, an internal polling sequence determines which request is serviced. Thus within each priority level there is a second priority structure determined by the polling sequence.

Table 23. IE Register
IE - Interrupt Enable Register (A8h)

7	6	5	4	3	2	1	0
EA	EC	ET2	ES	ET1	EX1	ET0	EX0
Bit Number	Bit Mnemonic	Description					
7	EA	Enable All interrupt bit Clear to disable all interrupts. Set to enable all interrupts. If EA=1, each interrupt source is individually enabled or disabled by setting or clearing its own interrupt enable bit.					
6	EC	PCA interrupt enable bit Clear to disable . Set to enable.					
5	ET2	Timer 2 overflow interrupt Enable bit Clear to disable timer 2 overflow interrupt. Set to enable timer 2 overflow interrupt.					
4	ES	Serial port Enable bit Clear to disable serial port interrupt. Set to enable serial port interrupt.					
3	ET1	Timer 1 overflow interrupt Enable bit Clear to disable timer 1 overflow interrupt. Set to enable timer 1 overflow interrupt.					
2	EX1	External interrupt 1 Enable bit Clear to disable external interrupt 1. Set to enable external interrupt 1.					
1	ET0	Timer 0 overflow interrupt Enable bit Clear to disable timer 0 overflow interrupt. Set to enable timer 0 overflow interrupt.					
0	EX0	External interrupt 0 Enable bit Clear to disable external interrupt 0. Set to enable external interrupt 0.					

Reset Value = 0000 0000b
Bit addressable



Table 24. IP Register
IP - Interrupt Priority Register (B8h)

7	6	5	4	3	2	1	0
-	PPC	PT2	PS	PT1	PX1	PT0	PX0

Bit Number	Bit Mnemonic	Description
7	-	Reserved The value read from this bit is indeterminate. Do not set this bit.
6	PPC	PCA interrupt priority bit Refer to PPCH for priority level.
5	PT2	Timer 2 overflow interrupt Priority bit Refer to PT2H for priority level.
4	PS	Serial port Priority bit Refer to PSH for priority level.
3	PT1	Timer 1 overflow interrupt Priority bit Refer to PT1H for priority level.
2	PX1	External interrupt 1 Priority bit Refer to PX1H for priority level.
1	PT0	Timer 0 overflow interrupt Priority bit Refer to PT0H for priority level.
0	PX0	External interrupt 0 Priority bit Refer to PX0H for priority level.

Reset Value = X000 0000b

Bit addressable

Table 25. IPH Register
IPH - Interrupt Priority High Register (B7h)

7	6	5	4	3	2	1	0
-	PPCH	PT2H	PSH	PT1H	PX1H	PT0H	PX0H
Bit Number	Bit Mnemonic	Description					
7	-	Reserved The value read from this bit is indeterminate. Do not set this bit.					
6	PPCH	PCA interrupt priority bit high. <u>PPCH</u> <u>PPC</u> <u>Priority Level</u> 0 0 Lowest 0 1 1 0 1 1 Highest					
5	PT2H	Timer 2 overflow interrupt Priority High bit <u>PT2H</u> <u>PT2</u> <u>Priority Level</u> 0 0 Lowest 0 1 1 0 1 1 Highest					
4	PSH	Serial port Priority High bit <u>PSH</u> <u>PS</u> <u>Priority Level</u> 0 0 Lowest 0 1 1 0 1 1 Highest					
3	PT1H	Timer 1 overflow interrupt Priority High bit <u>PT1H</u> <u>PT1</u> <u>Priority Level</u> 0 0 Lowest 0 1 1 0 1 1 Highest					
2	PX1H	External interrupt 1 Priority High bit <u>PX1H</u> <u>PX1</u> <u>Priority Level</u> 0 0 Lowest 0 1 1 0 1 1 Highest					
1	PT0H	Timer 0 overflow interrupt Priority High bit <u>PT0H</u> <u>PT0</u> <u>Priority Level</u> 0 0 Lowest 0 1 1 0 1 1 Highest					
0	PX0H	External interrupt 0 Priority High bit <u>PX0H</u> <u>PX0</u> <u>Priority Level</u> 0 0 Lowest 0 1 1 0 1 1 Highest					

Reset Value = X000 0000b
Not bit addressable



Power Management

Two power reduction modes are implemented in the T89C51RD2: the Idle mode and the Power-down mode. These modes are detailed in the following sections. In addition to these power reduction modes, the clocks of the core and peripherals can be dynamically divided by 2 using the X2 mode detailed in Section “X2 Feature”.

Reset

In order to start-up (cold reset) or to restart (warm reset) properly the microcontroller, a high level has to be applied on the RST pin. A bad level leads to a wrong initialization of the internal registers like SFRs, Program Counter... and to unpredictable behavior of the microcontroller. A proper device reset initializes the T89C51RD2 and vectors the CPU to address 0000h. RST input has a pull-down resistor allowing power-on reset by simply connecting an external capacitor to V_{DD} as shown in Figure 17. A warm reset can be applied either directly on the RST pin or indirectly by an internal reset source such as the watchdog timer. Resistor value and input characteristics are discussed in the Section “DC Characteristics” of the T89C51RD2 datasheet.

Figure 17. Reset Circuitry and Power-On Reset

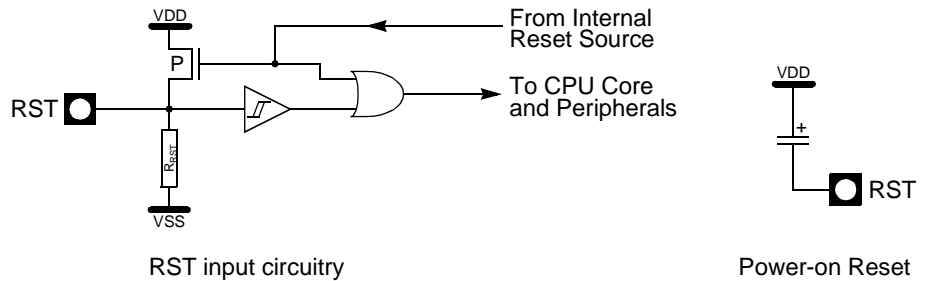

Cold Reset

2 conditions are required before enabling a CPU start-up:

- V_{DD} must reach the specified V_{DD} range
- The level on X1 input pin must be outside the specification (V_{IH} , V_{IL})

If one of these 2 conditions are not met, the microcontroller does not start correctly and can execute an instruction fetch from anywhere in the program space. An active level applied on the RST pin must be maintained till both of the above conditions are met. A reset is active when the level V_{IH1} is reached and when the pulse width covers the period of time where V_{DD} and the oscillator are not stabilized. 2 parameters have to be taken into account to determine the reset pulse width:

- V_{DD} rise time,
- Oscillator startup time.

To determine the capacitor value to implement, the highest value of these 2 parameters has to be chosen. Table 26 gives some capacitor values examples for a minimum R_{RST} of 50 K Ω and different oscillator startup and V_{DD} rise times.

Table 26. Minimum Reset Capacitor Value for a 50 kΩ Pull-down Resistor⁽¹⁾

Oscillator Start-Up Time	VDD Rise Time		
	1 ms	10 ms	100 ms
5 ms	820 nF	1.2 μF	12 μF
20 ms	2.7 μF	3.9 μF	12 μF

Note: These values assume V_{DD} starts from 0V to the nominal value. If the time between 2 on/off sequences is too fast, the power-supply de-coupling capacitors may not be fully discharged, leading to a bad reset sequence.

Warm Reset

To achieve a valid reset, the reset signal must be maintained for at least 2 machine cycles (24 oscillator clock periods) while the oscillator is running. The number of clock periods is mode independent (X2 or X1).

Watchdog Reset

As detailed in Section “Watchdog Timer”, the WDT generates a 96-clock period pulse on the RST pin. In order to properly propagate this pulse to the rest of the application in case of external capacitor or power-supply supervisor circuit, a 1 kΩ resistor must be added as shown Figure 18.

Figure 18. Reset Circuitry for WDT Reset-out Usage

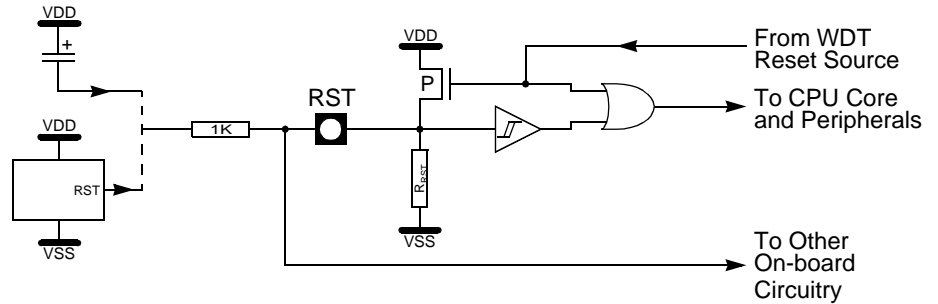

Reset Recommendation to Prevent Flash Corruption

Since the product includes a software area (bootloader) where the C51 core can operate Flash write operations, if the value of the Program Counter is accidentally in the range of the boot memory addresses then a Flash access (write or erase) may corrupt the Flash on-chip memory.

It is recommended to use an external reset circuitry featuring power supply monitoring to prevent system malfunction during periods of insufficient power supply voltage (power supply failure, power supply switched off).

Idle Mode

An instruction that sets PCON.0 indicates that it is the last instruction to be executed before going into Idle mode. In Idle mode, the internal clock signal is gated off to the CPU, but not to the interrupt, Timer, and Serial Port functions. The CPU status is preserved in its entirety: the Stack Pointer, Program Counter, Program Status Word, Accumulator and all other registers maintain their data during idle. The port pins hold the logical states they had at the time Idle was activated. ALE and PSEN hold at logic high level.

There are two ways to terminate the Idle mode. Activation of any enabled interrupt will cause PCON.0 to be cleared by hardware, terminating the Idle mode. The interrupt will be serviced, and following RETI the next instruction to be executed will be the one following the instruction that put the device into idle.

The flag bits GF0 and GF1 can be used to give an indication if an interrupt occurred during normal operation or during idle. For example, an instruction that activates idle can also set one or both flag bits. When idle is terminated by an interrupt, the interrupt service routine can examine the flag bits.

The other way of terminating the Idle mode is with a hardware reset. Since the clock oscillator is still running, the hardware reset needs to be held active for only two machine cycles (24 oscillator periods) to complete the reset.

Power-down Mode

To save maximum power, a Power-down mode can be invoked by software (see Table 14, PCON register).

In Power-down mode, the oscillator is stopped and the instruction that invoked Power-down mode is the last instruction executed. The internal RAM and SFRs retain their value until the Power-down mode is terminated. V_{CC} can be lowered to save further power. Either a hardware reset or an external interrupt can cause an exit from Power-down. To properly terminate Power-down, the reset or external interrupt should not be executed before V_{CC} is restored to its normal operating level and must be held active long enough for the oscillator to restart and stabilize.

Only external interrupts $\overline{INT0}$, $\overline{INT1}$ and Keyboard Interrupts are useful to exit from Power-down. For that, interrupt must be enabled and configured as level or edge sensitive interrupt input. When Keyboard Interrupt occurs after a power down mode, 1024 clocks are necessary to exit to power down mode and enter in operating mode.

Holding the pin low restarts the oscillator but bringing the pin high completes the exit as detailed in Figure 19. When both interrupts are enabled, the oscillator restarts as soon as one of the two inputs is held low and power down exit will be completed when the first input will be released. In this case, the higher priority interrupt service routine is executed. Once the interrupt is serviced, the next instruction to be executed after RETI will be the one following the instruction that puts the T89C51RD2 into Power-down mode.

Figure 19. Power-down Exit Waveform

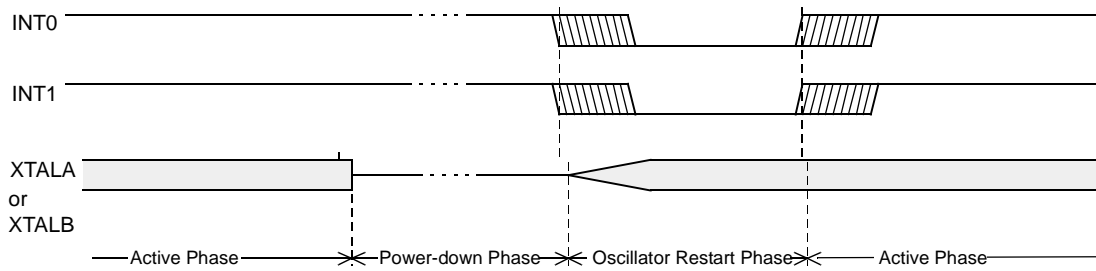

Exit from Power-down by reset redefines all the SFRs, exit from Power-down by external interrupt does not affect the SFRs.

Exit from Power-down by either reset or external interrupt does not affect the internal RAM content.

Note: If idle mode is activated with Power-down mode (IDL and PD bits set), the exit sequence is unchanged, when execution is vectored to interrupt, PD and IDL bits are cleared and idle mode is not entered.

Table 27 shows the state of ports during idle and power-down modes.

Table 27. State of Ports

Mode	Program Memory	ALE	PSEN	PORT0	PORT1	PORT2	PORT3
Idle	Internal	1	1	Port Data ⁽¹⁾	Port Data	Port Data	Port Data
Idle	External	1	1	Floating	Port Data	Address	Port Data
Power Down	Internal	0	0	Port Data ⁽¹⁾	Port Data	Port Data	Port Data
Power Down	External	0	0	Floating	Port Data	Port Data	Port Data

Port 0 can force a 0 level. A "one" will leave port floating.

Hardware Watchdog Timer

The WDT is intended as a recovery method in situations where the CPU may be subjected to software upset. The WDT consists of a 14-bit counter and the WatchDog Timer ReSeT (WDTRST) SFR. The WDT is by default disabled from exiting reset. To enable the WDT, user must write 01EH and 0E1H in sequence to the WDTRST, SFR location 0A6H. When WDT is enabled, it will increment every machine cycle while the oscillator is running and there is no way to disable the WDT except through reset (either hardware reset or WDT overflow reset). When WDT overflows, it will drive an output RESET HIGH pulse at the RST-pin.

Using the WDT

To enable the WDT, user must write 01EH and 0E1H in sequence to the WDTRST, SFR location 0A6H. When WDT is enabled, the user needs to service it by writing to 01EH and 0E1H to WDTRST to avoid WDT overflow. The 14-bit counter overflows when it reaches 16383 (3FFFH) and this will reset the device. When WDT is enabled, it will increment every machine cycle while the oscillator is running. This means the user must reset the WDT at least every 16383 machine cycle. To reset the WDT the user must write 01EH and 0E1H to WDTRST. WDTRST is a write only register. The WDT counter cannot be read or written. When WDT overflows, it will generate an output RESET pulse at the RST-pin. The RESET pulse duration is $96 \times T_{OSC}$, where $T_{OSC} = 1/F_{OSC}$. To make the best use of the WDT, it should be serviced in those sections of code that will periodically be executed within the time required to prevent a WDT reset.

To have a more powerful WDT, a 2^7 counter has been added to extend the Time-out capability, ranking from 16ms to 2s @ $F_{OSC} = 12\text{MHz}$. To manage this feature, refer to WDTPRG register description, Table 29. (SFR0A7h).

Table 28. WDTRST Register
WDTRST Address (0A6h)

	7	6	5	4	3	2	1
Reset value	X	X	X	X	X	X	X

Write only, this SFR is used to reset/enable the WDT by writing 01EH then 0E1H in sequence.

Table 29. WDTPRG Register
WDTPRG Address (0A7h)

7	6	5	4	3	2	1	0
T4	T3	T2	T1	T0	S2	S1	S0

Bit Number	Bit Mnemonic	Description
7	T4	Reserved The value read from this bit is undetermined. Do not try to set this bit..
6	T3	
5	T2	
4	T1	
3	T0	
2	S2	WDT Time-out select bit 2
1	S1	WDT Time-out select bit 1

Bit Number	Bit Mnemonic	Description																											
0	S0	WDT Time-out select bit 0																											
		<table border="1"> <thead> <tr> <th>S2</th> <th>S1</th> <th>S0Selected Time-out</th> </tr> </thead> <tbody> <tr> <td>0</td> <td>0</td> <td>$0(2^{14} - 1)$ machine cycles, 16.3 ms @ 12 MHz</td> </tr> <tr> <td>0</td> <td>0</td> <td>$1(2^{15} - 1)$ machine cycles, 32.7 ms @ 12 MHz</td> </tr> <tr> <td>0</td> <td>1</td> <td>$0(2^{16} - 1)$ machine cycles, 65.5 ms @ 12 MHz</td> </tr> <tr> <td>0</td> <td>1</td> <td>$1(2^{17} - 1)$ machine cycles, 131 ms @ 12 MHz</td> </tr> <tr> <td>1</td> <td>0</td> <td>$0(2^{18} - 1)$ machine cycles, 262 ms @ 12 MHz</td> </tr> <tr> <td>1</td> <td>0</td> <td>$1(2^{19} - 1)$ machine cycles, 542 ms @ 12 MHz</td> </tr> <tr> <td>1</td> <td>1</td> <td>$0(2^{20} - 1)$ machine cycles, 1.05 s @ 12 MHz</td> </tr> <tr> <td>1</td> <td>1</td> <td>$1(2^{21} - 1)$ machine cycles, 2.09 s @ 12 MHz</td> </tr> </tbody> </table>	S2	S1	S0Selected Time-out	0	0	$0(2^{14} - 1)$ machine cycles, 16.3 ms @ 12 MHz	0	0	$1(2^{15} - 1)$ machine cycles, 32.7 ms @ 12 MHz	0	1	$0(2^{16} - 1)$ machine cycles, 65.5 ms @ 12 MHz	0	1	$1(2^{17} - 1)$ machine cycles, 131 ms @ 12 MHz	1	0	$0(2^{18} - 1)$ machine cycles, 262 ms @ 12 MHz	1	0	$1(2^{19} - 1)$ machine cycles, 542 ms @ 12 MHz	1	1	$0(2^{20} - 1)$ machine cycles, 1.05 s @ 12 MHz	1	1	$1(2^{21} - 1)$ machine cycles, 2.09 s @ 12 MHz
S2	S1	S0Selected Time-out																											
0	0	$0(2^{14} - 1)$ machine cycles, 16.3 ms @ 12 MHz																											
0	0	$1(2^{15} - 1)$ machine cycles, 32.7 ms @ 12 MHz																											
0	1	$0(2^{16} - 1)$ machine cycles, 65.5 ms @ 12 MHz																											
0	1	$1(2^{17} - 1)$ machine cycles, 131 ms @ 12 MHz																											
1	0	$0(2^{18} - 1)$ machine cycles, 262 ms @ 12 MHz																											
1	0	$1(2^{19} - 1)$ machine cycles, 542 ms @ 12 MHz																											
1	1	$0(2^{20} - 1)$ machine cycles, 1.05 s @ 12 MHz																											
1	1	$1(2^{21} - 1)$ machine cycles, 2.09 s @ 12 MHz																											

Reset value XXXX X000

WDT During Power Down and Idle

In Power Down mode the oscillator stops, which means the WDT also stops. While in Power Down mode the user does not need to service the WDT. There are 2 methods of exiting Power Down mode: by a hardware reset or via a level activated external interrupt which is enabled prior to entering Power Down mode. When Power Down is exited with hardware reset, servicing the WDT should occur as it normally should whenever the T89C51RD2 is reset. Exiting Power Down with an interrupt is significantly different. The interrupt is held low long enough for the oscillator to stabilize. When the interrupt is brought high, the interrupt is serviced. To prevent the WDT from resetting the device while the interrupt pin is held low, the WDT is not started until the interrupt is pulled high. It is suggested that the WDT be reset during the interrupt service routine.

To ensure that the WDT does not overflow within a few states of exiting of powerdown, it is best to reset the WDT just before entering powerdown.

In the Idle mode, the oscillator continues to run. To prevent the WDT from resetting the T89C51RD2 while in Idle mode, the user should always set up a timer that will periodically exit Idle, service the WDT, and re-enter Idle mode.

If the WDT is activated, the power consumption in stand-by mode will be above the specified value.

ONCE™ Mode (ON Chip Emulation)

The ONCE mode facilitates testing and debugging of systems using T89C51RD2 without removing the circuit from the board. The ONCE mode is invoked by driving certain pins of the T89C51RD2; the following sequence must be exercised:

- Pull ALE low while the device is in reset (RST high) and $\overline{\text{PSEN}}$ is high.
- Hold ALE low as RST is deactivated.

While the T89C51RD2 is in ONCE mode, an emulator or test CPU can be used to drive the circuit. Table 30. shows the status of the port pins during ONCE mode.

Normal operation is restored when normal reset is applied.

Table 30. External Pin Status during ONCE Mode

ALE	PSEN	Port 0	Port 1	Port 2	Port 3	XTAL1/2
Weak pull-up	Weak pull-up	Float	Weak pull-up	Weak pull-up	Weak pull-up	Active

(a) "Once" is a registered trademark of Intel Corporation.

Reduced EMI Mode

The ALE signal is used to demultiplex address and data buses on port 0 when used with external program or data memory. Nevertheless, during internal code execution, ALE signal is still generated. In order to reduce EMI, ALE signal can be disabled by setting AO bit.

The AO bit is located in AUXR register at bit location 0. As soon as AO is set, ALE is no longer output but remains active during MOVX and MOVC instructions and external fetches. During ALE disabling, ALE pin is weakly pulled high.

Table 31. AUXR Register
AUXR - Auxiliary Register (8Eh)

7	6	5	4	3	2	1	0
-	-	M0	-	XRS1	XRS0	EXTRAM	AO

Bit Number	Bit Mnemonic	Description
7	-	Reserved The value read from this bit is indeterminate. Do not set this bit.
6	-	Reserved The value read from this bit is indeterminate. Do not set this bit.
5	M0	M0 bit: Pulse length in clock period Stretch MOVX control: the RD/ and the WR/ pulse length is increased according to the value of M0. see table 6
4	-	Reserved The value read from this bit is indeterminate. Do not set this bit.
3	XRS1	XRS1 bit XRAM size: Accessible size of the XRAM. See Table 6.
2	XRS0	XRS0 bit XRAM size: Accessible size of the XRAM. Table 6.
1	EXTRAM	EXTRAM bit See Table 6.
0	AO	ALE Output bit Clear to restore ALE operation during internal fetches. Set to disable ALE operation during internal fetches.

Reset Value = XX0X 1000b
Not bit addressable

EEPROM Data Memory

General Description

The EEPROM memory block contains 2048 bytes and is organized in 32 pages (or rows) of 64 bytes. The necessary high programming voltage is generated on-chip using the standard Vcc pin of the microcontroller.

The EEPROM memory block is located at the addresses 0000h to 07FFh of the XRAM memory space and is selected by setting control bits in the EECON register.

A read in the EEPROM memory is done with a MOVX instruction.

A physical write in the EEPROM memory is done in two steps : write data in the column latches and transfer of all data latches in a EEPROM memory row (programming).

The number of data written in the page may vary from 1 to 64 (the page size). When programming, only the data written in the column latch are programmed. This provides the capability to program the whole memory by bytes, by page or by a number of bytes in a page.

Write Data in the Column Latches

Data is written by byte to the column latches as if it was in an external RAM memory. Out of the 16 address bits of the data pointer, the 10 MSB are used for page selection and 6 are used for byte selection. Between two EEPROM programming, all addresses in the column latches must remain in the same page, thus the 10MSB must be unchanged.

The following procedure is used to write in the columns latches :

- Map the program space (Set bit EEE of EECON register)
- Load DPTR with the address to write
- Load A register with the data to be written
- Execute a MOVX @DPTR, A
- If needed loop the three last instructions until the end of a 64bytes page

Programming

The EEPROM programming consists on the following actions :

- write one or more bytes in a page in the column latches. Normally, all bytes must belong to the same page; if this is not the case, the first page address is latched and the others are discarded.
- Set EETIM with the value corresponding to the XTAL frequency.
- Launch the programming by writing the control sequence (52h or 50h followed by A2h or A0h) to the EECON register (see Table 32).
- EEBUSY flag in EECON is then set by hardware to indicate that programming is in progress and that EEPROM segment is not available for read.
- The end of programming is signaled by a hardware clear of the EEBUSY flag.

Example : ; DPTR = EEPROM data pointer, A = Data to write

```

Wait :      MOV      A,EECON
           ANL      A,#01h
           JNZ      Wait
           MOV      EETIM,#3Ch           ; 12MHz*5 = 3Ch
           MOV      EECON,#02h           ; EEE=1 EEPROM mapped
           MOVX    @DPTR,A               ; Write data to EEPROM
           MOV      EECON,#50h or 52h   ; Write Sequence
           MOV      EECON,#A0h or A2h
           .....

```

Read Data

The following procedure is used to read the data store in the EEPROM memory:

- Map the program space (Set bit EEE of EECON register)
- Load DPTR with the address to read
- Execute a MOVX A, @DPTR

```
Example : ... ; DPTR = EEPROM data pointer
MOV EECON,#02h ; EEE=1 EEPROM mapped
MOVX A,@DPTR ; Read data from EEPROM
... ; A = Data
```

Registers

Table 32. EECON Register

EECON (S:0D2h)
EEPROM Control Register

7	6	5	4	3	2	1	0
EEPL3	EEPL2	EEPL1	EEPL0	-	-	EEE	EEBUSY
Bit Number	Bit Mnemonic	Description					
7-4	EEPL3-0	Programming Launch command bits Write 5Xh followed by AXh to EECON to launch the programming.					
3	-	Not implemented, reserved for future use. ⁽¹⁾					
2	-	Not implemented, reserved for future use. ⁽²⁾					
1	EEE	Enable EEPROM Space bit Set to map the EEPROM space during MOVX instructions (Write in the column latches) Clear to map the data space during MOVX.					
0	EEBUSY	Programming Busy flag Set by hardware when programming is in progress. Cleared by hardware when programming is done. Can not be set or cleared by software.					

1. User software should not write 1s to reserved bits. These bits may be used in future 8051 family products to invoke new features. In that case, the reset or inactive value of the new bit will be 0, and its active value will be 1. The value read from a reserved bit is indeterminate.
2. User software should not write 1s to reserved bits. These bits may be used in future 8051 family products to invoke new features. In that case, the reset or inactive value of the new bit will be 0, and its active value will be 1. The value read from a reserved bit is indeterminate.

Reset Value = XXXX XX00b

Table 33. EETIM Register

EETIM (S:0D3h)
EEPROM timing Control Register

7	6	5	4	3	2	1	0
EETIM							
Bit Number	Bit Mnemonic	Description					
7-0	EETIM	Write Timer Register The write timer register value is required to adapt the write time to the oscillator frequency Value = 5 * Fxtal (MHz) in normal mode, 10 * Fxtal in X2 mode. Example : Fxtal = 33 MHZ, EETIM = 0A5h					

Reset Value = 0000 0000b

Flash EEPROM Memory

General Description

The Flash memory increases EPROM and ROM functionality with in-circuit electrical erasure and programming. It contains 64K bytes of program memory organized in 512 pages of 128 bytes. This memory is both parallel and serial In-System Programmable (ISP). ISP allows devices to alter their own program memory in the actual end product under software control. A default serial loader (bootloader) program allows ISP of the Flash.

The programming does not require 12v external programming voltage. The necessary high programming voltage is generated on-chip using the standard V_{CC} pins of the microcontroller.

Features

- Flash E2PROM internal program memory.
- The last 1K bytes of the Flash is used to store the low-level in-system programming routines and a default serial loader. If the application does not need to use the ISP and does not expect to modify the Flash content, the Boot Flash sector can be erased to provide access to the full 64K byte Flash memory.
- Boot vector allows user provided Flash loader code to reside anywhere in the Flash memory space. This configuration provides flexibility to the user.
- Default loader in Boot Flash allows programming via the serial port without the need of a user provided loader.
- Up to 64K byte external program memory if the internal program memory is disabled (EA = 0).
- Programming and erase voltage with standard 5V or 3V V_{CC} supply.
- Read/Programming/Erase:
- Byte-wise read (without wait state).
- Byte or page erase and programming (10 ms).
- Typical programming time (63K bytes) in 20 s.
- Parallel programming with 87C51 compatible hardware interface to programmer.
- Programmable security for the code in the Flash.
- 100k write cycles
- 10 years data retention

Flash Programming and Erasure

The 64K bytes Flash is programmed by bytes or by pages of 128 bytes. It is not necessary to erase a byte or a page before programming. The programming of a byte or a page includes a self erase before programming.

There are three methods to program the Flash memory:

- First, the on-chip ISP bootloader may be invoked which will use low level routines to program the pages. The interface used for serial downloading of Flash is the UART.
- Second, the Flash may be programmed or erased in the end-user application by calling low-level routines through a common entry point in the Boot loader.
- Third, the Flash may be programmed using the parallel method by using a conventional EPROM programmer. The parallel programming method used by

these devices is similar to that used by EPROM 87C51 but it is not identical and the commercially available programmers need to have support for the T89C51RD2.

The bootloader and the In Application Programming (IAP) routines are located in the last kilobyte of the Flash, leaving 63k bytes available for the application with ISP.

Flash Registers and Memory Map

The T89C51RD2 Flash memory uses several registers for his management:

- Flash control register is used to select the Flash memory spaces and launch the Flash programming sequence.
- Hardware registers can only be accessed through the parallel programming modes which are handled by the parallel programmer.
- Software registers are in a special page of the Flash memory which can be accessed through the API or with the parallel programming modes. This page, called "Extra Flash Memory", is not in the internal Flash program memory addressing space.

Flash Register

Figure 20. FCON register
FCON (S:D1h) Flash control register

7	6	5	4	3	2	1	0
FPL3	FPL2	FPL1	FPL0	FPS	FMOD1	FMOD0	FBUSY
Bit Number	Bit Mnemonic	Description					
7-4	FPL3:0	Programming Launch command bits Write 5h followed by Ah to launch the programming.					
3	FPS	Flash Map Program Space Clear to map the data space during MOVX Set to map the Flash space during MOVX (write) or MOVC (read) instructions (Write in the column latches)					
2-1	FMOD1:0	Flash Mode Select the addressed space 00: User (0000h-FFFFh) 01: XAF 10: Hardware byte 11: reserved					
0	FBUSY	Flash Busy Set by hardware when programming is in progress. Clear by hardware when programming is done. Can not be cleared by software					

Reset Value = xxxx 0000b

The Flash programming application note and API source code are available on request.

Hardware register

The only hardware register of the T89C51RD2 is called Hardware Security Byte (HSB). After full Flash erasure, the content of this byte is FFh; each bit is active at low level.

7	6	5	4	3	2	1	0
SB	BLJB	BLLB	-	-	LB2	LB1	LB0
Bit Number	Bit Mnemonic	Description					
7	SB	Safe Bit This bit must be cleared to secure the content of the HSB. Only security level can be increased.					
6	BLJB	Boot loader Jump Bit Set to force hardware boot address at 0000h. (unless previously force by hardware conditions as described in the chapter 9.6). Clear to force hardware boot address at FC03h (default).					
5	BLLB	Boot loader Lock Bit Set to allow programming and writing of the boot loader segment. Clear to forbid software programming and writing of the boot loader segment (default). This protection protect only ISP or IAP access; protection through parallel access is done globally by the lock bits LB2-0.					
4	-	Reserved Do not clear this bit.					
3	-	Reserved Do not clear this bit.					
2-0	LB2-0	User Memory Lock Bits See Table 29					

Boot Loader Lock Bit (BLLB)

One bit of the HSB is used to secure by hardware the internal boot loader sector against software reprogramming.

When the BLLB is cleared, any attempt to write in the boot loader segment (Address FC00h to FFFFh) will have no effect. This protection applies for software writing only.

Boot Loader Jump Bit (BLJB)

One bit of the HSB, the BLJB bit, is used to force the boot address:

- When this bit is set the boot address is 0000h.
- When this bit is reset the boot address is FC03h. By default, this bit is cleared and the ISP is enabled.

Flash memory lock bits

The three lock bits provide different levels of protection for the on-chip code and data, when programmed according to Table 29.

Table 34. Program Lock bits

Program Lock Bits				Protection Description
Security level	LB0	LB1	LB2	
1	U	U	U	No program lock features enabled. MOVC instruction executed from external program memory returns non encrypted data.
2	P	U	U	MOVC instruction executed from external program memory are disabled from fetching code bytes from internal memory, EA is sampled and latched on reset, and further parallel programming of the Flash is disabled. ISP and software programming with API are still allowed.
3	X	P	U	Same as 2, also verify through parallel programming interface is disabled.
4	X	X	P	Same as 3, also external execution is disabled.

Note: U: unprogrammed or "one" level.

Note: P: programmed or "zero" level.

Note: X:do not care

Note: WARNING: Security level 2 and 3 should only be programmed after Flash and code verification.

These security bits protect the code access through the parallel programming interface. They are set by default to level 4. The code access through the ISP is still possible and is controlled by the "software security bits" which are stored in the extra Flash memory accessed by the ISP firmware.

To load a new application with the parallel programmer, a chip erase must first be done. This will set the HSB in its inactive state and will erase the Flash memory, including the boot loader and the "Extra Flash Memory" (XAF). If needed, the 1K boot loader and the XAF content must be programmed in the Flash; the code is provided by ATMEL Wireless and Microcontrollers (see section 8.7.); the part reference can always be read using Flash parallel programming modes.

Default Values

The default value of the HSB provides parts ready to be programmed with ISP:

- SB: Cleared to secure the content of the HSB.
- BLJB: Cleared to force ISP operation.
- BLLB: Clear to protect the default boot loader.
- LB2-0: Security level four to protect the code from a parallel access with maximum security.

Software Registers

Several registers are used, in factory and by parallel programmers, to make copies of hardware registers contents. These values are used by ATMEL Wireless and Microcontrollers ISP (see section 8.7.).

These registers are in the "Extra Flash Memory" part of the Flash memory. This block is also called "XAF" or eXtra Array Flash. They are accessed in the following ways:

- Commands issued by the parallel memory programmer.
- Commands issued by the ISP software.

Calls of API issued by the application software.

They are several software registers described in Table 35

Table 35. Default Values

Mnemonic		Default Value	
BSB	Boot Status Byte	FFh	
SBV	Software Boot Vector	FCh	
HSB	Copy of the Hardware security byte	18h or 1Bh	
SSB	Software Security Byte	FFh	
	Copy of the Manufacturer Code	58h	ATMEL Wireless and Microcontrollers
	Copy of the Device ID #1: Family Code	D7h	C51 X2, Electrically Erasable
	Copy of the Device ID #2: memories size and type	FCh	T89C51RD2 memories size
	Copy of the Device ID # 3: name and revision	FFh	T89C51RD2, revision 0

After programming the part by ISP, the BSB must be reset (00h) in order to allow the application to boot at 0000h.

The content of the Software Security Byte (SSB) is described in Table 30 and Table 31

To assure code protection from a parallel access, the HSB must also be at the required level.

The three lock bits provide different levels of protection for the on-chip code and data, when programmed according to Table 31.

Table 36. Program Lock bits of the SSB

Program Lock Bits			Protection Description
Security level	LB0	LB1	
1	U	U	No program lock features enabled.
2	P	U	following commands are disabled: - program byte - program status byte and boot vector - erase status byte and boot vector
3	X	P	Same as 2 and following commands also disabled: - read byte - read status byte and boot vector - blank check - program SSB level2

Note: U: unprogrammed or "one" level.

Note: P: programmed or "zero" level.

Note: X: do not care

Note: WARNING: Security level 2 and 3 should only be programmed after Flash and code verification.



Flash Memory Status

T89C51RD2 parts are delivered in standard with the ISP boot in the Flash memory. After ISP or parallel programming, the possible contents of the Flash memory are summarized on the figure below:

Figure 21. Flash Memory Possible Contents

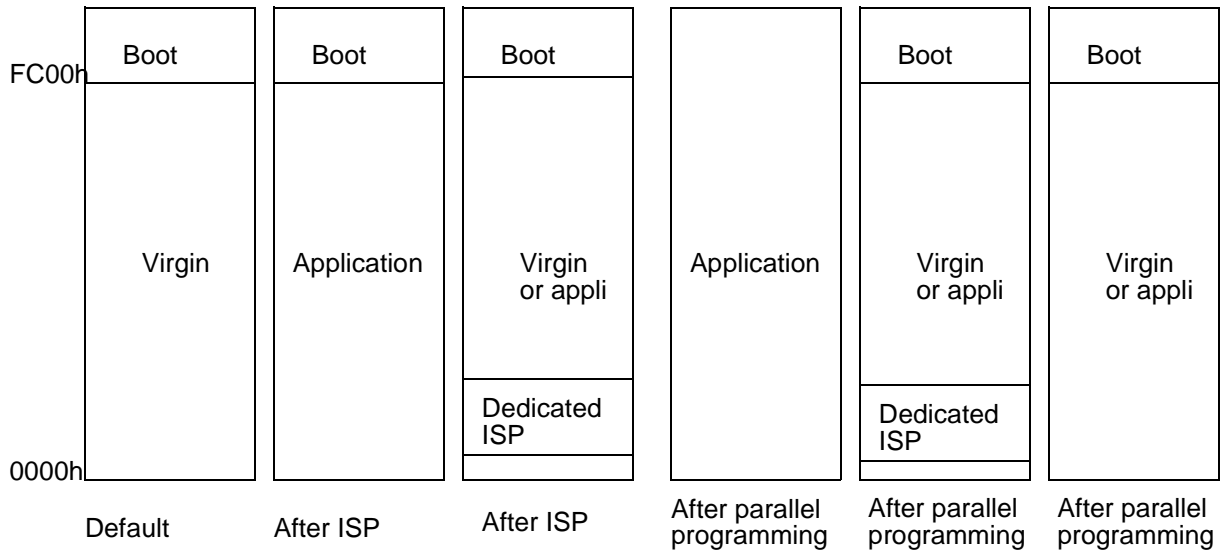

Bootloader Architecture

Introduction

The bootloader manages a communication according to a specific defined protocol to provide the whole access and service on Flash memory. Furthermore, all accesses and routines can be called from the user application.

Figure 22. Diagram Context Description

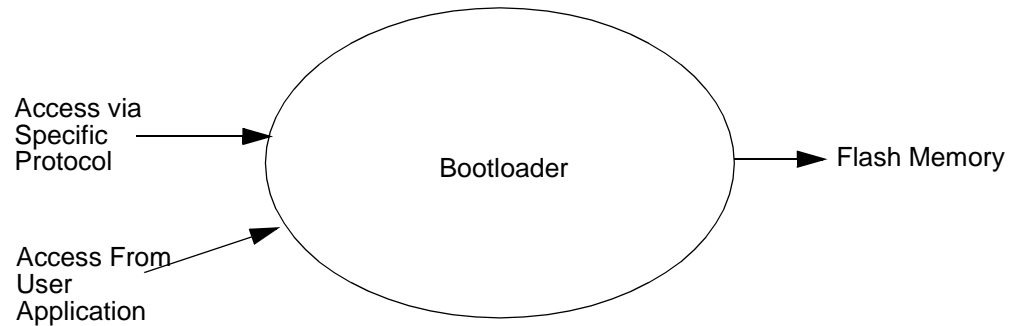

Acronyms

ISP: In-system Programming

SBV: Software Boot Vector

BSB: Boot Status Byte

SSB: Software Security Bit

Functional Description

Figure 23. Bootloader Functional Description

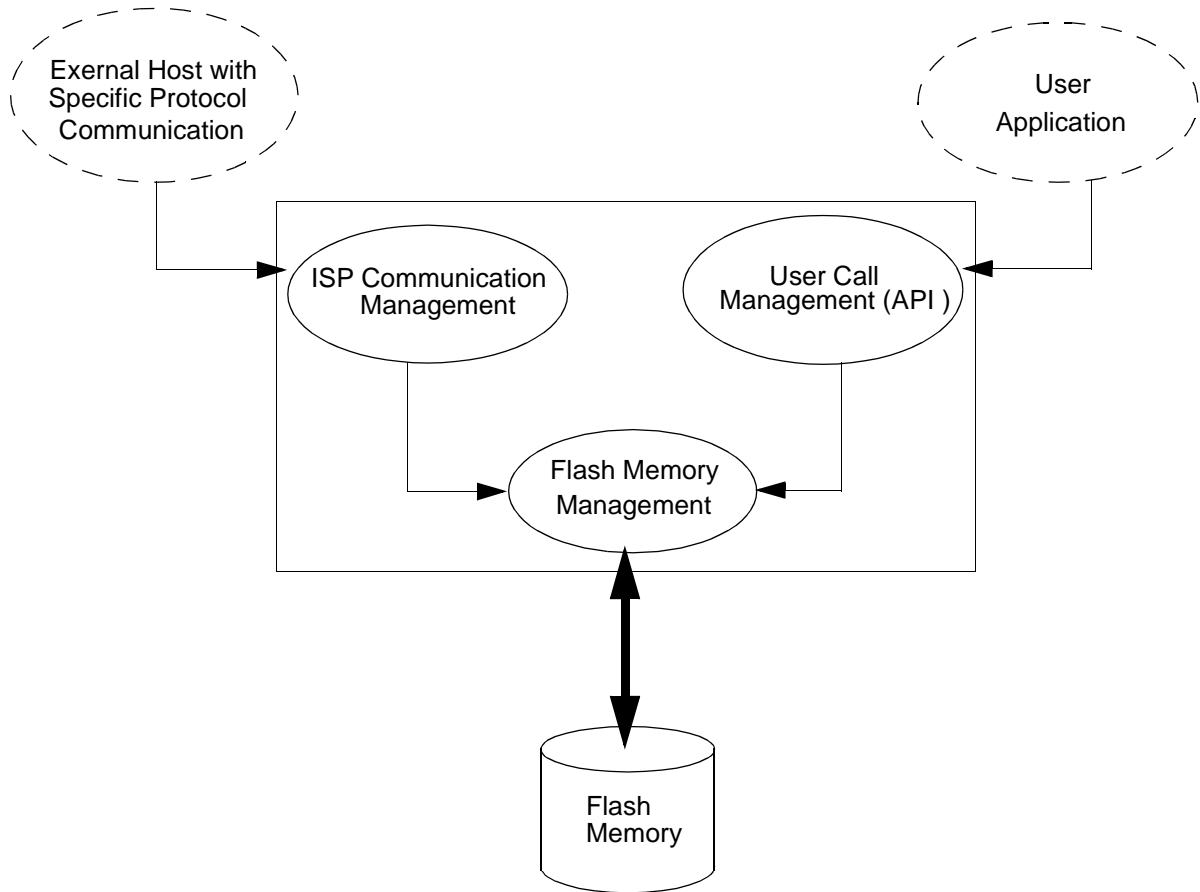

On the above diagram, the on-chip bootloader processes are:

- ISP Communication Management

The purpose of this process is to manage the communication and its protocol between the on-chip bootloader and an external device. The on-chip ROM implements a serial protocol (see section Bootloader Protocol). This process translates serial communication frames (UART) into Flash memory access (read, write, erase ...).

- User Call Management

Several Application Program Interface (API) calls are available for use by an application program to permit selective erasing and programming of Flash pages. All calls are made through a common interface (API calls), included in the ROM bootloader. The programming functions are selected by setting up the microcontroller's registers before making a call to a common entry point (0xFFFF). Results are returned in the registers. The purpose of this process is to translate the registers' values into internal Flash Memory Management.

- Flash Memory Management

This process manages low-level access to Flash memory (performs read and write access).

Bootloader Functionality

Introduction

The bootloader can be activated by two means: Hardware conditions or regular boot process.

The Hardware conditions (EA = 1, PSEN = 0) during the Reset# falling edge force the on-chip bootloader execution. This allows an application to be built that will normally execute the end user's code but can be manually forced into default ISP operation.

As PSEN is an output port in normal operating mode (running user application or bootloader code) after reset, it is recommended to release PSEN after falling edge of reset signal. The hardware conditions are sampled at reset signal falling edge, thus they can be released at any time when reset input is low.

The on-chip bootloader boot process is shown in Figure 24.

	Purpose
Hardware Conditions	The Hardware Conditions force the bootloader execution whatever BLJB, BSB and SBV values.
BLJB	<p>The Boot Loader Jump Bit forces the application execution. BLJB = 0 => Boot loader execution. BLJB = 1 => Application execution.</p> <p>The BLJB is a fuse bit in the Hardware Byte. That can be modified by hardware (programmer) or by software (API).</p> <p>Note: The BLJB test is perform by hardware to prevent any program execution.</p>
SBV	<p>The Software Boot Vector contains the high address of customer bootloader stored in the application. SBV = FCh (default value) if no customer bootloader in user Flash.</p> <p>Note: The customer bootloader is called by LJMP [SBV]00h instruction.</p>

Boot Process

Figure 24. Bootloader Process

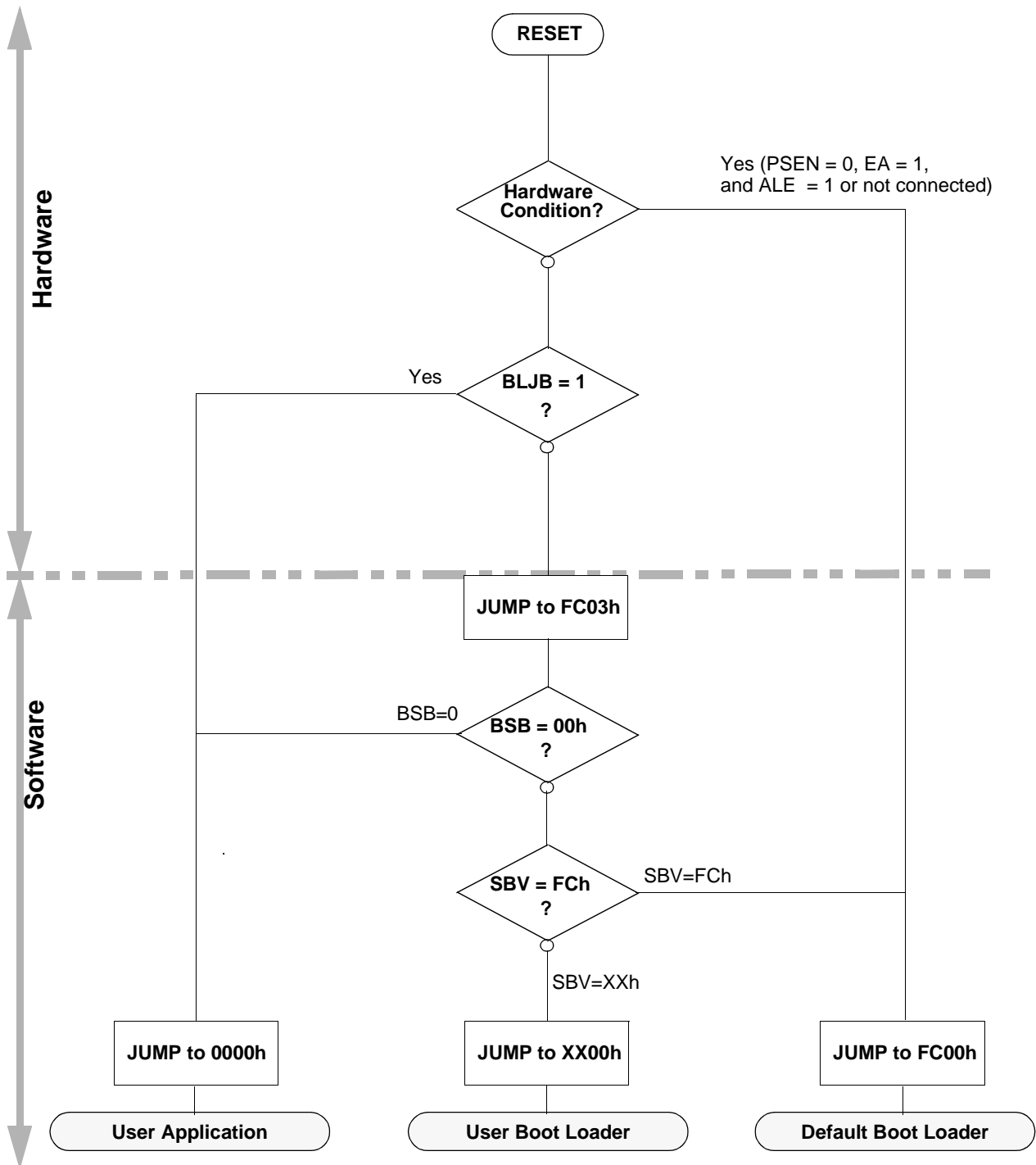

ISP Protocol Description

Physical Layer

The UART used to transmit information has the following configuration:

- Character: 8-bit data
- Parity: none
- Stop: 1 bit
- Flow control: none
- Baud rate: autobaud is performed by the bootloader to compute the baud rate chosen by the host.

Frame Description

The Serial Protocol is based on the Intel Hex-type records.

Intel Hex records consist of ASCII characters used to represent hexadecimal values and are summarized below.

Table 37. Intel Hex Type Frame

Record Mark ':'	Reclen	Load Offset	Record Type	Data or Info	Checksum
1 byte	1 byte	2 bytes	1 bytes	n byte	1 byte

- Record Mark:
 - Record Mark is the start of frame. This field must contain ':'.
- Reclen:
 - Reclen specifies the number of Bytes of information or data which follows the Record Type field of the record.
- Load Offset:
 - Load Offset specifies the 16-bit starting load offset of the data Bytes, therefore this field is used only for
 - Data Program Record (see Section "ISP Commands Summary").
- Record Type:
 - Record Type specifies the command type. This field is used to interpret the remaining information within the frame. The encoding for all the current record types is described in Section "ISP Commands Summary".
- Data/Info:
 - Data/Info is a variable length field. It consists of zero or more Bytes encoded as pairs of hexadecimal digits. The meaning of data depends on the Record Type.
- Checksum:
 - The two's complement of the 8-bit Bytes that result from converting each pair of ASCII hexadecimal digits to one Byte of binary, and including the Reclen field to and including the last Byte of the Data/Info field. Therefore, the sum of all the ASCII pairs in a record after converting to binary, from the Reclen field to and including the Checksum field, is zero.

Functional Description

Configuration and Manufacturer Information

The table below lists Configuration and Manufacturer byte information used by the boot-loader. This information can be accessed through a set of API or ISP commands.

Mnemonic	Description	Default Value
BSB	Boot Status Byte	FFh
SBV	Software Boot Vector	FCh
SSB	Software Security Byte	FFh
Manufacturer Id		58h
Id1: Family code		D7h
Id2: Product Name		FCh
Id3: Product Revision		FFh

Software Security Bits (SSB)

The SSB protects any Flash access from ISP command. The command "Program Software Security bit" can only write a higher priority level.

There are three levels of security:

- level 0: **NO_SECURITY** (FFh)

This is the default level.

From level 0, one can write level 1 or level 2.

- level 1: **WRITE_SECURITY** (10h)

For this level it is impossible to write in the Flash memory, BSB and SBV.

The Bootloader returns 'P' on write access.

From level 1, one can write only level 2.

- level 2: **RD_WR_SECURITY** (00h)

The level 2 forbids all read and write accesses to/from the Flash/EEPROM memory.

The Bootloader returns 'L' on read or write access.

Only a full chip erase in parallel mode (using a programmer) or ISP command can reset the software security bits.

From level 2, one cannot read and write anything.

Table 38. Software Security Byte Behavior

	Level 0	Level 1	Level 2
Flash/EEPROM	Any access allowed	Read only access allowed	Any access not allowed
Fuse Bit	Any access allowed	Read only access allowed	Any access not allowed
BSB & SBV	Any access allowed	Read only access allowed	Any access not allowed
SSB	Any access allowed	Write level 2 allowed	Read only access allowed

	Level 0	Level 1	Level 2
Manufacturer Info	Read only access allowed	Read only access allowed	Read only access allowed
Bootloader Info	Read only access allowed	Read only access allowed	Read only access allowed
Erase Block	Allowed	Not allowed	Not allowed
Full-chip Erase	Allowed	Allowed	Allowed
Blank Check	Allowed	Allowed	Allowed

Full Chip Erase

The ISP command "Full Chip Erase" erases all User Flash memory (fills with FFh) and sets some Bytes used by the bootloader at their default values:

- BSB = FFh
- SBV = FCh
- SSB = FFh and finally erase the Software Security Bits

The Full Chip Erase does not affect the bootloader.

Checksum Error

When a checksum error is detected send 'X' followed with CR&LF.

Flow Description

Overview

An initialization step must be performed after each Reset. After microcontroller reset, the bootloader waits for an autobaud sequence (see section 'autobaud performance').

When the communication is initialized the protocol depends on the record type requested by the host.

FLIP, a software utility to implement ISP programming with a PC, is available from the Atmel the web site.

Communication Initialization

The host initializes the communication by sending a 'U' character to help the bootloader to compute the baudrate (autobaud).

Figure 25. Initialization

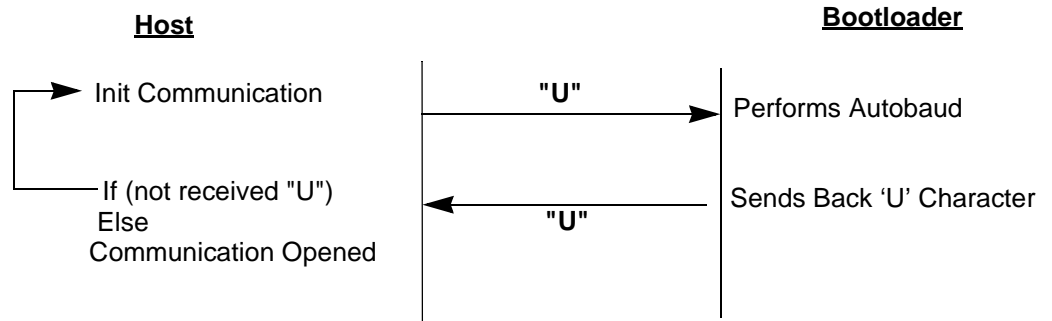

Autobaud Performances

The ISP feature allows a wide range of baud rates in the user application. It is also adaptable to a wide range of oscillator frequencies. This is accomplished by measuring the bit-time of a single bit in a received character. This information is then used to program the baud rate in terms of timer counts based on the oscillator frequency. The ISP feature requires that an initial character (an uppercase U) be sent to the T89C51RD2 to establish the baud rate. Table 39 shows the autobaud capability.

Table 39. Autobaud Performances (Bootloader Revision 2.4)

Frequency (MHz) Baudrate (bit/s)	1.8432	2	2.4576	3	3.6864	4	5	6	7.3728	8
4800	OK	OK	OK	OK	OK	OK	OK	OK	OK	-
9600	OK	OK	OK	OK	OK	OK	-	OK	OK	OK
19200	OK	OK	OK	OK	OK	OK	OK	OK	OK	OK
38400	-	OK	-	-	OK	OK	OK	OK	OK	OK
57600	-	-	-	-	OK	-	-	-	OK	-
115200	-	-	-	-	-	-	-	-	OK	-
Frequency (MHz) Baudrate (bit/s)	10	11.0592	12	14.318	14.746	16	20	24	26.6	32
4800	OK	OK	OK	OK	OK	-	-	-	-	-
9600	OK	OK	OK	OK	OK	OK	OK	OK	OK	-
19200	-	OK	OK	OK	OK	OK	OK	OK	OK	OK
38400	OK	OK	OK	OK	OK			OK	OK	OK
57600	-	OK	-		OK	OK	OK	OK	OK	OK
115200	-	OK	-		OK	-	-	-	-	OK

Command Data Stream Protocol

All commands are sent using the same flow. Each frame sent by the host is echoed by the bootloader.

Figure 26. Command Flow

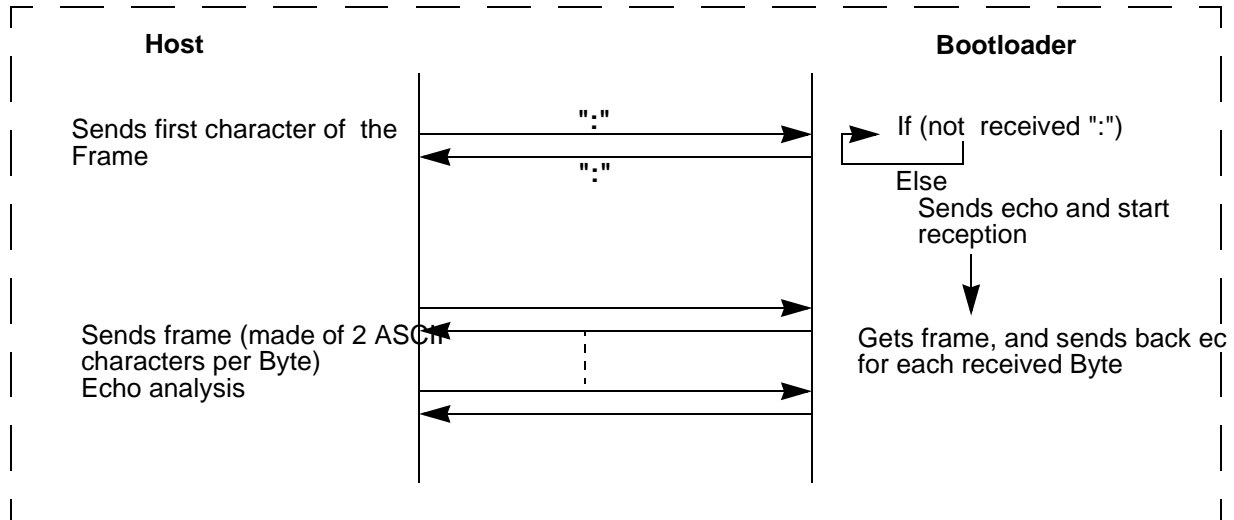

Write/Program Commands

This flow is common to the following frames:

- Flash/EEPROM Programming Data Frame
- EOF or Atmel Frame (only Programming Atmel Frame)
- Config Byte Programming Data Frame
- Baud Rate Frame

Description

Figure 27. Write/Program Flow

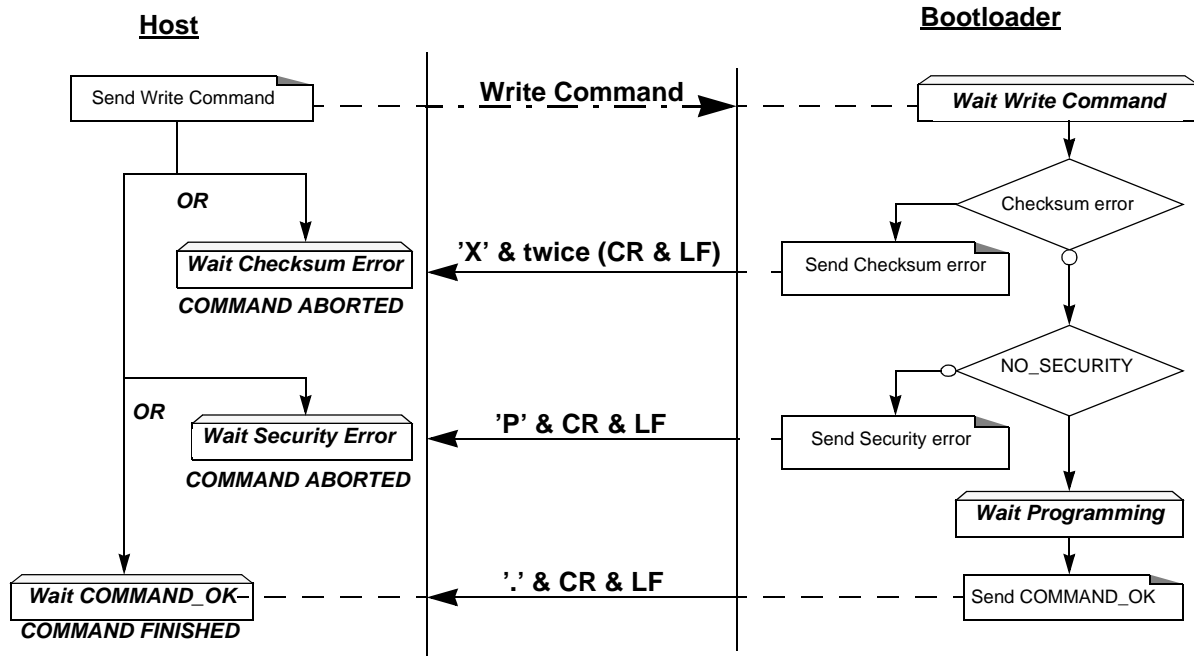

Example

Programming Data (write 55h at address 0010h in the Flash)

HOST : 01 0010 00 55 9A
 BOOTLOADER : 01 0010 00 55 9A . CR LF

Programming Atmel function (write SSB to level 2)

HOST : 02 0000 03 05 01 F5
 BOOTLOADER : 02 0000 03 05 01 F5. CR LF

Writing Frame (write BSB to 55h)

HOST : 03 0000 03 06 00 55 9F
 BOOTLOADER : 03 0000 03 06 00 55 9F . CR LF

Blank Check Command

Description

Figure 28. Blank Check Flow

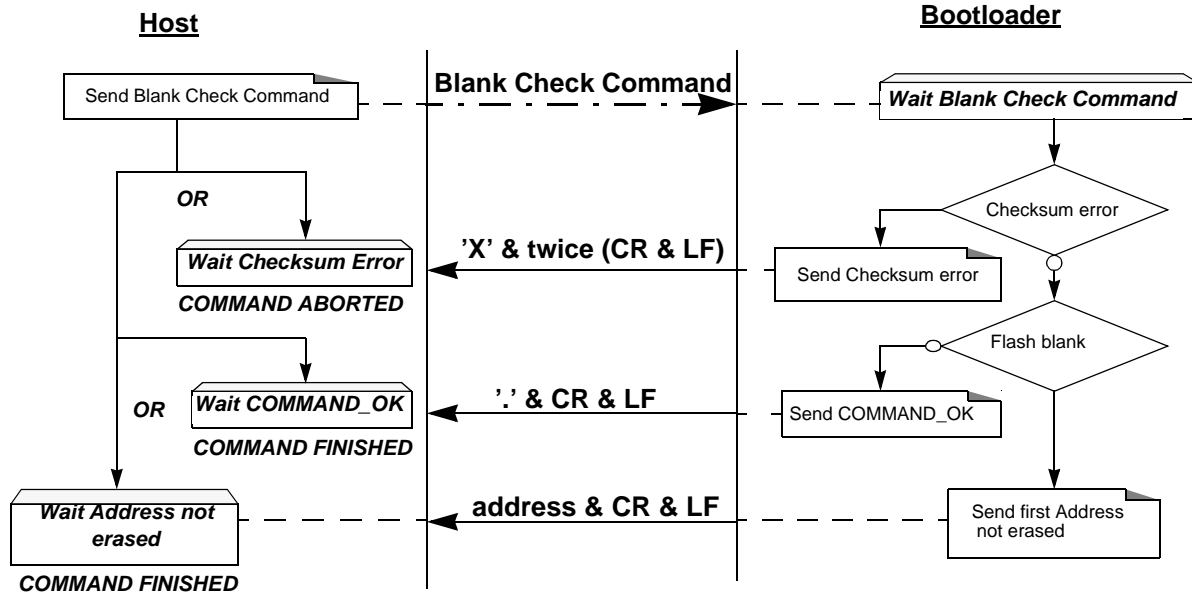

Example

Blank Check ok

```

HOST          : 05 0000 04 0000 7FFF 01 78
BOOTLOADER    : 05 0000 04 0000 7FFF 01 78 . CR LF
  
```

Blank Check ko at address xxxx

```

HOST          : 05 0000 04 0000 7FFF 01 78
BOOTLOADER    : 05 0000 04 0000 7FFF 01 78 xxxx CR LF
  
```

Blank Check with checksum error

```

HOST          : 05 0000 04 0000 7FFF 01 70
BOOTLOADER    : 05 0000 04 0000 7FFF 01 70 X CR LF CR LF
  
```

Display Data

Description

Figure 29. Display Flow

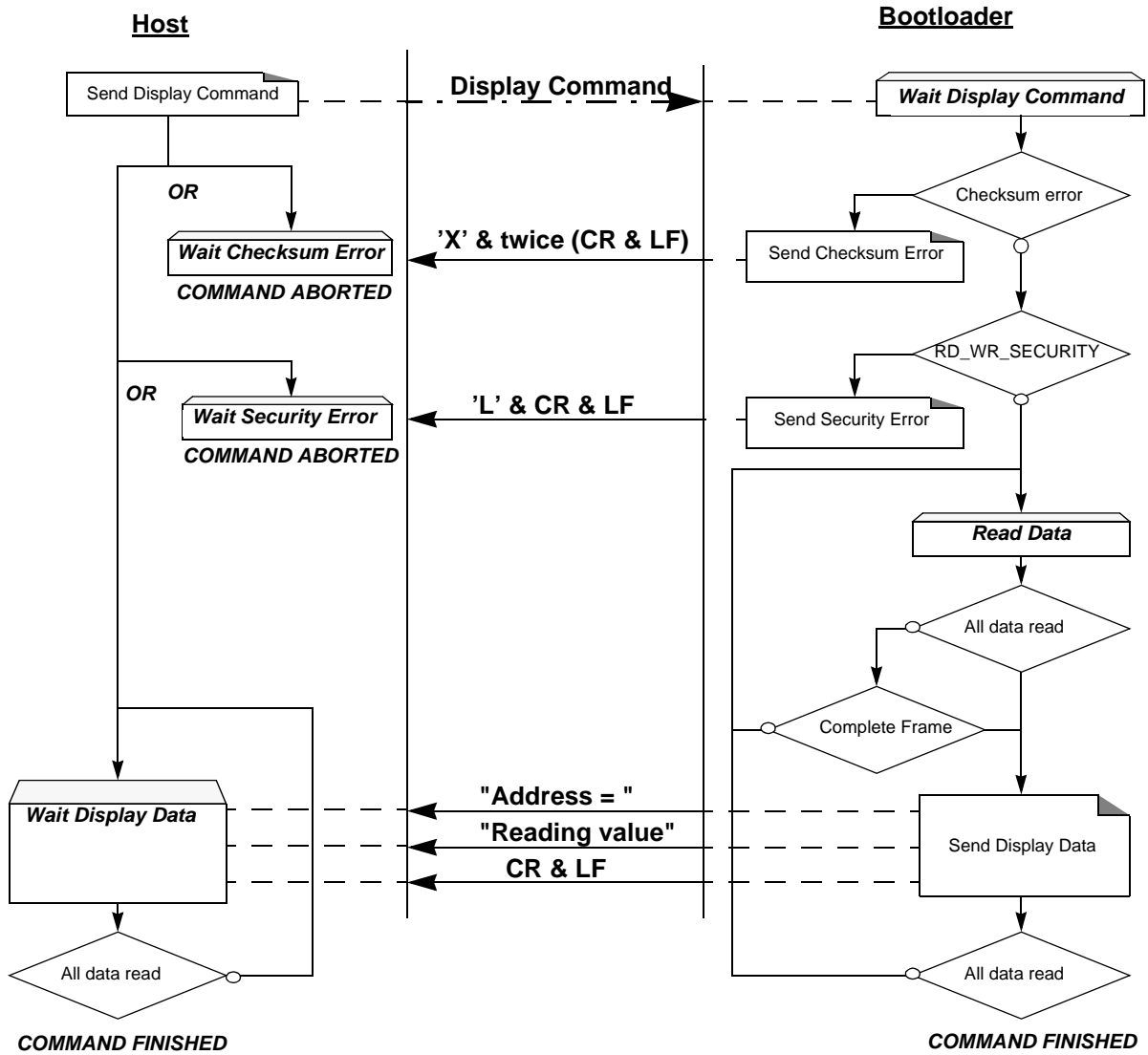

Note: The maximum size of block is 400h. To read more than 400h Bytes, the Host must send a new command.

Example

Display data from address 0000h to 0020h

```

HOST          : 05 0000 04 0000 0020 00 D7
BOOTLOADER    : 05 0000 04 0000 0020 00 D7
BOOTLOADER    0000=-----data----- CR LF   (16 data)
BOOTLOADER    0010=-----data----- CR LF   (16 data)
BOOTLOADER    0020=data CR LF                  ( 1 data)
    
```

Read Function

This flow is similar for the following frames:

- Reading Frame
- EOF Frame/Atmel Frame (only reading Atmel Frame)

Description

Figure 30. Read Flow

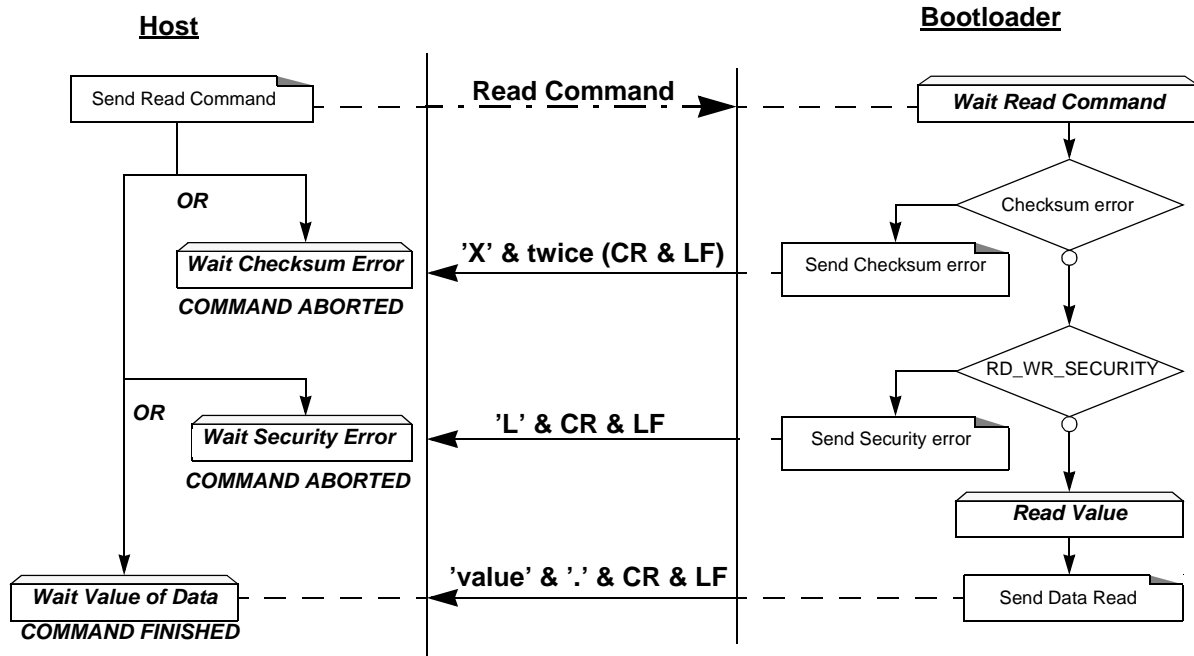

Example

Read function (read SBV)

```

HOST          : 02 0000 05 07 02 F0
BOOTLOADER    : 02 0000 05 07 02 F0 Value . CR LF
    
```

Atmel Read function (read Bootloader version)

```

HOST          : 02 0000 01 02 00 FB
BOOTLOADER    : 02 0000 01 02 00 FB Value . CR LF
    
```

ISP Commands Summary

Table 40. ISP Commands Summary

Command	Command Name	Data[0]	Data[1]	Command Effect
00h	Program Data			Program Nb Data Byte. Bootloader will accept up to 16 (10h) data Bytes. The data Bytes should be 128 Byte page Flash boundary.
03h	Write Function	04h	00h	Erase SBV
		05h	00h	Program SSB level 1
			01h	Program SSB level 2
		06h	00h	Program BSB (value to write in data[2])
			01h	Program SBV (value to write in data[2])
07h	-	Full Chip Erase		
04h	Display Function	Data[0:1] = start address Data [2:3] = end address		Display Data
		Data[4] = 00h -> Display data Data[4] = 01h -> Blank check		Blank Check
05h	Read Function	00h	00h	Manufacturer ID
			01h	Device ID #1
			02h	Device ID #2
			03h	Device ID #3
		07h	00h	Read SSB
			01h	Read BSB
			02h	Read SBV
			03h	Read Hardware Byte Copy
		08h	00h	Read Bootloader Version
		0Eh	00h	Read Device Boot ID1
01h	Read Device Boot ID2			

API Call Description

Several Application Program Interface (API) calls are available for use by an application program to permit selective erasing and programming of Flash pages. All calls are made through a common interface, PGM_MTP. The programming functions are selected by setting up the microcontroller's registers before making a call to PGM_MTP at FFF0h. Results are returned in the registers.

When several Bytes have to be programmed, it is highly recommended to use the Atmel API "PROGRAM DATA PAGE" call. Indeed, this API call writes up to 128 Bytes in a single command.

All routines for software access are provided in the C Flash driver available at Atmel's web site.

The API calls description and arguments are shown in Table 41.

Table 41. API Call Summary

Command	R1	A	DPTR0	DPTR1	Returned Value	Command Effect
READ MANUF ID	00h	XXh	0000h	XXh	ACC=Manufacturer ID	Read Manufacturer identifier
READ DEVICE ID1	00h	XXh	0001h	XXh	ACC= Device ID 1	Read Device identifier 1
READ DEVICE ID2	00h	XXh	0002h	XXh	ACC=Device ID 2	Read Device identifier 2
READ DEVICE ID3	00h	XXh	0003h	XXh	ACC=Device ID 3	Read Device identifier 3
PROGRAM DATA BYTE	02h	Byte value to program	Address of Byte to program		ACC = 0 : DONE	Program one Data Byte in user Flash
ERASE BOOT VECTOR	04h	XXh	XXh	XXh	ACC=FCh	Erase Software boot vector and boot status Byte. (SBV=FCh and BSB=FFh)
PROGRAM SSB	05h	XXh	DPH = 00h DPL = 00h	00h	ACC= SSB value	Set SSB level 1
			DPH = 00h DPL = 01h			Set SSB level 2
			DPH = 00h DPL = 10h			Set SSB level 0
			DPH = 00h DPL = 11h			Set SSB level 1
PROGRAM BSB	06h	New BSB value	0000h	XXh	none	Program boot status Byte
PROGRAM SBV	06h	New SBV value	0001h	XXh	none	Program software boot vector
READ SSB	07h	XXh	0000h	XXh	ACC=SSB	Read Software Security Byte
READ HSB	07h	XXh	0004h	XXh	ACC=HSB	Read Hardware Byte
READ BSB	07h	XXh	0001h	XXh	ACC=BSB	Read Boot Status Byte
READ SBV	07h	XXh	0002h	XXh	ACC=SBV	Read Software Boot Vector
PROGRAM DATA PAGE	09h	Number of Byte to program	Address of the first Byte to program in the Flash memory	Address in XRAM of the first data to program	ACC = 0 : DONE	Program up to 128 Bytes in user Flash. Remark: number of Bytes to program is limited such as the Flash write remains in a single 128 Bytes page. Hence, when ACC is 128, valid values of DPL are 00h, or 80h.
READ BOOT ID1	0Eh	XXh	DPL = 00h	XXh	ACC=ID1	Read boot ID1
READ BOOT ID2	0Eh	XXh	DPL = 01h	XXh	ACC=ID2	Read boot ID2
READ BOOT VERSION	0Fh	XXh	XXXXh	XXh	ACC=Boot_Version	Read bootloader version

Flash Parallel Programming

Signature Bytes

Four hardware read only registers have to be accessed with parallel static test modes (mode TMS) in order to control the Flash parallel programming:

- Manufacturer code
- Device ID # 1: Family code
- Device ID # 2: Memories size and type
- Device ID # 3: Name and revision

As these registers can only be accessed by hardware, they must be read by the parallel programmers and then copied in the XAF in order to make their values accessible by software (ISP or API).

Set-up modes Configuration

In order to program and verify the Flash or to read the signature bytes, the T89C51RD2 is placed in specific set-up modes. (See Figure 31.)

Figure 31. Set-Up Modes Configuration

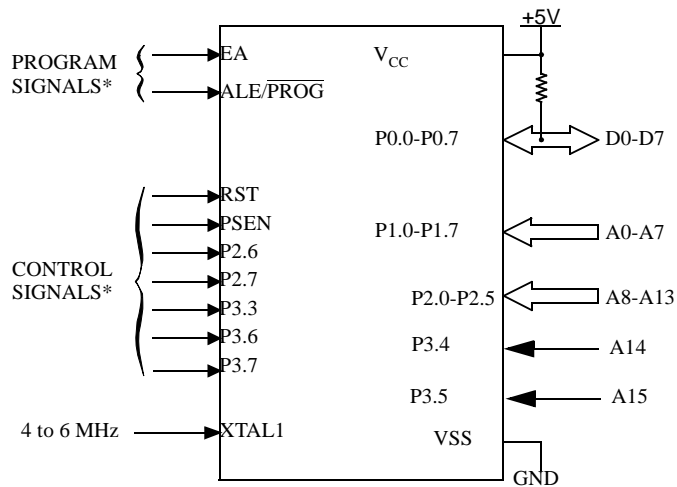

Definition of Terms

Address Lines: P1.0-P1.7, P2.0-P2.5, P3.4-P3.5, respectively for A0-A15.

Data Lines: P0.0-P0.7 for D0-D7

Control Signals: RST, $\overline{\text{PSEN}}$, P2.6, P2.7, P3.2, P3.3, P3.6, P3.7.

Program Signals: ALE/ $\overline{\text{PROG}}$, $\overline{\text{EA}}$

Set-up modes configuration

Control and program signals must be held at the levels indicated in the two following tables.

Mode Name	Mode	Rst	Psen	Ale -- _	EA	P2.6	P2.7	P3.6	P3.7	P0[7..0]
PELCK	Program or Erase Lock. Disable the Erasure or Programming access	1	0	-- _	1	1	0	1	0	xx
PEULCK	Program or Erase UnLock. Enable the Erasure or Programming access	1	0	Note 2	1	1	0	1	0	55-AA
PGMC	Write Code Data (byte) or write Page Always preceded by PGML	1	0	-- _ Internally timed	1	0	1	1	1	xx
PGML	Memory Page Load (up to 128 bytes)	1	0	Note 1	1	0	1	0	1	Din
PGMV	Read Code Data (byte)	1	0	1	1	0	-- _	1	1	Dout
VSB	Read Security Byte (=HSB)	1	0	1	1	0	-- _	0	1	Dout
PGMS	Write Security Byte (Note 3) (security byte = HSB)	1	0	10 ms	1	1	1	0	0	Din
CERR	Chip Erase User + XAF	1	0	100 ms	1	1	0	0	0	xx
PGXC	Write Byte or Page in Extra Memory (XAF) Always preceded by PGXL	1	0	-- _ Internally timed	1	1	1	0	1	xx
PGXL	Memory Page Load XAF (up to 128 bytes)	1	0	Note 1	1	1	1	0	1	Din
TMS	Read Signature bytes 30h (Manufacturer code) 31h (Device ID #1) 60h (Device ID #2) 61h (Device ID #3)	1	0	1	1	0	-- _	0	0	Dout = 58h D7h FCh FFh
RXAF	Read Extra Memory (XAF)	1	0	1	1	0	-- _	0	0	Dout

Mode Name	Mode	P1[7..0]	P2[5..0]	P3.0	P3.1	P3.2	P3.3	P3.4	P3.5
PELCK	Program or Erase Lock. Disable the Erasure or Programming access	xx	xx	x	x	x	1	x	x
PEULCK	Program or Erase UnLock. Enable the Erasure or Programming access	xx	xx	x	x	x	0	x	x
PGMC	Write Code Data (byte) or write Page Always preceded by PGML	A7-A0	A13-A8	1	x	x	0	A14	A15
PGML	Memory Page Load (up to 128 bytes)	A7-A0	A13-A8	1	x	x	0	A14	A15
PGMV	Read Code Data (byte)	A7-A0	A13-A8	1	x	x	1	A14	A15
VSB	Read Security Byte (=HSB)	xx	xx	1	x	x	1	x	x
PGMS	Write lock Byte (Note 4) (security byte = HSB)	xx	xx	1	x	x	0	x	x
CERR	Chip Erase User + XAF	xx	xx	1	x	x	0	x	x
PGXC	Write Byte or Page Extra Memory (XAF) Always preceded by PGXL	A7-A0 (0-7F)	xx	1	x	x	0	x	x
PGXL	Memory Page Load XAF (up to 128 bytes)	A7-A0 (0-7F)	xx	1	x	x	1	x	x
TMS	Read Signature bytes 30h (Manufacturer code) 31h (Device ID #1) 60h (Device ID #2) 61h (Device ID #3)	30h 31h 60h 61h	x	x	x	x	1	x	x
RXAF	Read Extra Memory (XAF)	Addr (0-7F)	00	1	x	x	0	x	x

- In Page Load Mode the current byte is loaded on ALE rising edge.
- After a power up all external test mode to program or to erase the Flash are locked to avoid any untimely programming or erasure.
After each programming or erasure test mode, it's advised to lock this feature (test mode PELCK).
To validate the test mode mode PEULCK the following sequence has to be applied: Test Mode PEULCK with ALE = 1.
Pulse on ALE (min width=25clk) with P0=55 (P0 latched on ALE rising edge)
Pulse on ALE (min width=25clk) with P0=AA (P0 latched on ALE rising edge)
- The highest security bit (bit 7) is used to secure the 7 lowest bit erasure. The only way to erase this bit is to erase the whole Flash memory.
Procedure to program security bits (After array programming):
- program bit7 to 0, program all other bits (1 = erased, 0 = programmed).
- test mode PGMS (din = HSB).
Procedure to erase security byte:
- test mode CERR: erase all array included HSB.
- program hardware security byte to FF: test mode PGMS (din = FF).

Programming Algorithm

To program the T89C51RD2 the following sequence must be exercised:

- Check the signature bytes
- Check the HSB (VSB mode)

If the security bits are activated, the following commands must be done before programming:

- Unlock test modes (PEULCK mode, pulse 55h and AAh)
- Chip erase (CERR mode)
- Write FFh in the HSB (PGMS mode)
- Write the signature bytes content in the XAF
- As the boot loader and the XAF content is lost after a "chip erase", it must be reprogrammed if needed.
- Disable programming access (PELCK mode)

To write a page in the Flash memory, execute the following steps:

- Step 0: Enable programming access (PEULCK mode)
- Step 1: Activate the combination of control signals (PGML mode)
- Step 2: Input the valid address on the address lines (High order bits of the address must be stable during the complete ALE low time)
- Step 3: Activate the combination of control signals (PGML mode)
- Step 4: Input the appropriate data on the data lines.
- Step 5: Pulse ALE/ $\overline{\text{PROG}}$ once.

Repeat step 2 through 5 changing the address and data for end of a 128 bytes page

- Step 6: Enable programming access (PEULCK mode)
- Step 7: Activate the combination of control signals (PGMC mode)
- Step 8: Input the valid address on the address lines.
- Step 9: Pulse ALE/ $\overline{\text{PROG}}$ once the specified write time is reached.

Repeat step 0 through 9 changing the address and data until the entire array or until the end of the object file is reached (See Figure 32.)

- Step 10: Disable programming access (PELCK mode)

Verify Algorithm

Verify must be done after each byte or block of bytes is programmed. In either case, a complete verify of the programmed array will ensure reliable programming of the T89C51RD2.

P 2.7 is used to enable data output.

To verify the T89C51RD2 code the following sequence must be exercised:

- Step 1: Activate the combination of program and control signals (PGMV)
- Step 2: Input the valid address on the address lines.
- Step 3: Read data on the data lines.

Repeat step 2 through 3 changing the address for the entire array verification (See Figure 32.).

Figure 32. Programming and Verification Signal's Waveform

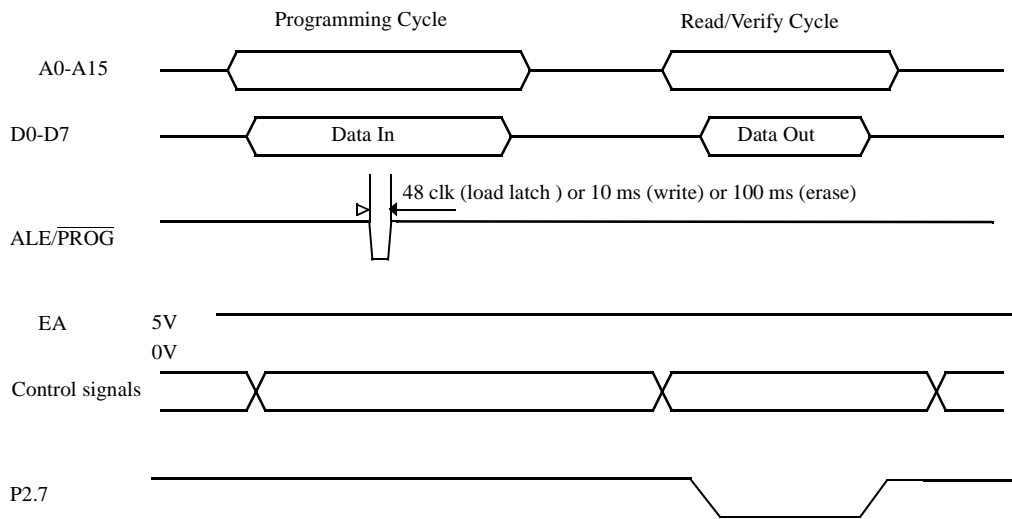

Extra Memory Mapping

The memory mapping the T89C51RD2 software registers in the Extra Flash memory is described in the table below.

Table 42. Extra Row Memory Mapping (XAF)

	Address	Default content
Copy of device ID #3	0061h	FFh
Copy of device ID #2	0060h	FCh
Copy of device ID #1	0031h	D7h
Copy of Manufacturer Code: ATMEL	0030h	58h
Software Security Byte (level 1 by default)	0005h	FFh
Copy of HSB (level 4 by default and BLJB = 0)	0004h	18h or 1Bh
Software Boot Vector	0001h	FCh
Boot Status Byte	0000h	FFh

All other addresses are reserved

Electrical Characteristics

Absolute Maximum Ratings

Ambient Temperature Under Bias:
 C = commercial 0°C to 70°C
 I = industrial -40°C to 85°C
 Storage Temperature -65°C to +150°C
 Voltage on V_{CC} V_{SS} -0.5 V to +6.5V
 Voltage on Any Pin V_{SS} -0.5 V to $V_{CC}+0.5$ V
 Power Dissipation 1 W⁽²⁾

*NOTICE: Stresses at or above those listed under “Absolute Maximum Ratings” may cause permanent damage to the device. This is a stress rating only and functional operation of the device at these or any other conditions above those indicated in the operational sections of this specification is not implied. Exposure to absolute maximum rating conditions may affect device reliability. Power dissipation value is based on the maximum allowable die temperature and the thermal resistance of the package.

DC Parameters for Standard Voltage

$T_A = 0^\circ\text{C}$ to $+70^\circ\text{C}$; $V_{SS} = 0$ V; $V_{CC} = 5$ V \pm 10%; F = 0 to 40 MHz.
 $T_A = -40^\circ\text{C}$ to $+85^\circ\text{C}$; $V_{SS} = 0$ V; $V_{CC} = 5$ V \pm 10%; F = 0 to 40 MHz.

Table 43. DC Parameters in Standard Voltage ⁽¹⁾

Symbol	Parameter	Min	Typ ⁽⁵⁾	Max	Unit	Test Conditions
V_{IL}	Input Low Voltage	-0.5		$0.2 V_{CC} - 0.1$	V	
V_{IH}	Input High Voltage except XTAL1, RST	$0.2 V_{CC} + 0.9$		$V_{CC} + 0.5$	V	
V_{IH1}	Input High Voltage, XTAL1, RST	$0.7 V_{CC}$		$V_{CC} + 0.5$	V	
V_{OL}	Output Low Voltage, ports 1, 2, 3, 4 and 5 ⁽⁶⁾			0.3	V	$I_{OL} = 100 \mu\text{A}^{(4)}$
				0.45	V	$I_{OL} = 1.6 \text{ mA}^{(4)}$
				1.0	V	$I_{OL} = 3.5 \text{ mA}^{(4)}$
V_{OL1}	Output Low Voltage, port 0, ALE, $\overline{\text{PSEN}}$ ⁽⁶⁾			0.3	V	$I_{OL} = 200 \mu\text{A}^{(4)}$
				0.45	V	$I_{OL} = 3.2 \text{ mA}^{(4)}$
				1.0	V	$I_{OL} = 7.0 \text{ mA}^{(4)}$
V_{OH}	Output High Voltage, ports 1, 2, 3, 4 and 5	$V_{CC} - 0.3$			V	$I_{OH} = -10 \mu\text{A}$
		$V_{CC} - 0.7$			V	$I_{OH} = -30 \mu\text{A}$
		$V_{CC} - 1.5$			V	$I_{OH} = -60 \mu\text{A}$ $V_{CC} = 5 \text{ V} \pm 10\%$
V_{OH1}	Output High Voltage, port 0, ALE, $\overline{\text{PSEN}}$	$V_{CC} - 0.3$			V	$I_{OH} = -200 \mu\text{A}$
		$V_{CC} - 0.7$			V	$I_{OH} = -3.2 \text{ mA}$
		$V_{CC} - 1.5$			V	$I_{OH} = -7.0 \text{ mA}$ $V_{CC} = 5 \text{ V} \pm 10\%$
R_{RST}	RST Pulldown Resistor	50	90	200	k Ω	
I_{IL}	Logical 0 Input Current ports 1, 2, 3, 4 and 5			-50	μA	$V_{in} = 0.45 \text{ V}$
I_{LI}	Input Leakage Current for P0 only			± 10	μA	$0.45 \text{ V} < V_{in} < V_{CC}$
I_{TL}	Logical 1 to 0 Transition Current, ports 1, 2, 3, 4 and 5			-650	μA	$V_{in} = 2.0 \text{ V}$

Table 43. DC Parameters in Standard Voltage ⁽¹⁾

Symbol	Parameter	Min	Typ ⁽⁵⁾	Max	Unit	Test Conditions
C _{IO}	Capacitance of I/O Buffer			10	pF	F _c = 1 MHz T _A = 25°C
I _{PD}	Power Down Current		120	150	μA	V _{CC} = 3 V to 5.5 V ⁽³⁾
I _{CCOP}	Power Supply Current on normal mode			0.7 Freq (MHz) + 3	mA	V _{CC} = 5.5 V ⁽¹⁾
I _{CCProgFlash}	Power Supply Current during Flash Write / Erase		0.3 Freq (MHz) + 10	0.4 Freq (MHz) + 12	mA	V _{CC} = 5.5 V ⁽¹⁾
I _{CCProgEE}	Power Supply Current during EEPROM data Write / Erase		0.7 Freq (MHz) + 3	0.7 Freq (MHz) + 18	mA	V _{CC} = 5.5 V ⁽¹⁾
I _{CCIDLE}	Power Supply Current on idle mode			0.4 Freq (MHz) + 2	mA	V _{CC} = 5.5 V ⁽²⁾

DC Parameters for Standard Voltage (2)

T_A = 0°C to +70°C; V_{SS} = 0 V; V_{CC} = 3 V to 5.5 V; F = 0 to 33 MHz.

T_A = -40°C to +85°C; V_{SS} = 0 V; V_{CC} = 3 V to 5.5 V; F = 0 to 33 MHz.

Table 44. DC Parameters for Standard Voltage ⁽²⁾

Symbol	Parameter	Min	Typ ⁽⁵⁾	Max	Unit	Test Conditions
V _{IL}	Input Low Voltage	-0.5		0.2 V _{CC} - 0.1	V	
V _{IH}	Input High Voltage except XTAL1, RST	0.2 V _{CC} + 0.9		V _{CC} + 0.5	V	
V _{IH1}	Input High Voltage, XTAL1, RST	0.7 V _{CC}		V _{CC} + 0.5	V	
V _{OL}	Output Low Voltage, ports 1, 2, 3, 4 and 5 ⁽⁶⁾			0.45	V	I _{OL} = 0.8 mA ⁽⁴⁾
V _{OL1}	Output Low Voltage, port 0, ALE, $\overline{\text{PSEN}}$ ⁽⁶⁾			0.45	V	I _{OL} = 1.6 mA ⁽⁴⁾
V _{OH}	Output High Voltage, ports 1, 2, 3, 4 and 5	0.9 V _{CC}			V	I _{OH} = -10 μA
V _{OH1}	Output High Voltage, port 0, ALE, $\overline{\text{PSEN}}$	0.9 V _{CC}			V	I _{OH} = -40 μA
I _{IL}	Logical 0 Input Current ports 1, 2, 3, 4 and 5			-50	μA	V _{in} = 0.45 V
I _{LI}	Input Leakage Current for P0 only			±10	μA	0.45 V < V _{in} < V _{CC}
I _{TL}	Logical 1 to 0 Transition Current, ports 1, 2, 3, 4 and 5			-650	μA	V _{in} = 2.0 V
R _{RST}	RST Pulldown Resistor	50	90	200	kΩ	
C _{IO}	Capacitance of I/O Buffer			10	pF	F _c = 1 MHz T _A = 25°C
I _{PD}	Power Down Current		120	150	μA	V _{CC} = 3 V to 5.5 V ⁽³⁾
I _{CCOP}	Power Supply Current on normal mode			0.7 Freq (MHz) + 3 mA	mA	V _{CC} = 5.5 V ⁽¹⁾

Table 44. DC Parameters for Standard Voltage ⁽²⁾

Symbol	Parameter	Min	Typ ⁽⁵⁾	Max	Unit	Test Conditions
$I_{CCProgFlash}$	Power Supply Current during Flash Write / Erase		0.3 Freq (MHz) + 10	0.4 Freq (MHz) + 12	mA	$V_{CC} = 5.5 V^{(1)}$
$I_{CCProgEE}$	Power Supply Current during EEprom data Write / Erase		0.7 Freq (MHz) + 3	0.7 Freq (MHz) + 18	mA	$V_{CC} = 5.5 V^{(1)}$
I_{CCIDLE}	Power Supply Current on idle mode			0.5 Freq (MHz) + 2 mA	mA	$V_{CC} = 5.5 V^{(2)}$

DC Parameters for Low Voltage

$T_A = 0^\circ\text{C}$ to $+70^\circ\text{C}$; $V_{SS} = 0\text{ V}$; $V_{CC} = 2.7\text{ V}$ to 3.6 V ; $F = 0$ to 25 MHz
 $T_A = -40^\circ\text{C}$ to $+85^\circ\text{C}$; $V_{SS} = 0\text{ V}$; $V_{CC} = 2.7\text{ V}$ to 3.6 V ; $F = 0$ to 25 MHz

Table 45. DC Parameters for Low Voltage

Symbol	Parameter	Min	Typ ⁽⁵⁾	Max	Unit	Test Conditions
V_{IL}	Input Low Voltage	-0.5		$0.2 V_{CC} - 0.1$	V	
V_{IH}	Input High Voltage except XTAL1, RST	$0.2 V_{CC} + 0.9$		$V_{CC} + 0.5$	V	
V_{IH1}	Input High Voltage, XTAL1, RST	$0.7 V_{CC}$		$V_{CC} + 0.5$	V	
V_{OL}	Output Low Voltage, ports 1, 2, 3, 4 and 5 ⁽⁶⁾			0.45	V	$I_{OL} = 0.8\text{ mA}^{(4)}$
V_{OL1}	Output Low Voltage, port 0, ALE, $\overline{\text{PSEN}}$ ⁽⁶⁾			0.45	V	$I_{OL} = 1.6\text{ mA}^{(4)}$
V_{OH}	Output High Voltage, ports 1, 2, 3, 4 and 5	$0.9 V_{CC}$			V	$I_{OH} = -10\ \mu\text{A}$
V_{OH1}	Output High Voltage, port 0, ALE, $\overline{\text{PSEN}}$	$0.9 V_{CC}$			V	$I_{OH} = -40\ \mu\text{A}$
I_{IL}	Logical 0 Input Current ports 1, 2, 3, 4 and 5			-50	μA	$V_{in} = 0.45\text{ V}$
I_{LI}	Input Leakage Current			± 10	μA	$0.45\text{ V} < V_{in} < V_{CC}$
I_{TL}	Logical 1 to 0 Transition Current, ports 1, 2, 3, 4 and 5			-650	μA	$V_{in} = 2.0\text{ V}$
R_{RST}	RST Pulldown Resistor	50	90	200	$\text{k}\Omega$	
CIO	Capacitance of I/O Buffer			10	pF	$F_c = 1\text{ MHz}$ $T_A = 25^\circ\text{C}$
I_{PD}	Power Down Current		1	50	μA	$V_{CC} = 2.7\text{ V}$ to $3.6\text{ V}^{(3)}$
I_{CCOP}	Power Supply Current on normal mode			$0.6\text{ Freq (MHz)} + 3$	mA	$V_{CC} = 3.6\text{ V}^{(1)}$
$I_{CCProgFlash}$	Power Supply Current during Flash Write / Erase		$0.3\text{ Freq (MHz)} + 10$	$0.4\text{ Freq (MHz)} + 12$	mA	$V_{CC} = 3.6\text{ V}^{(1)}$
$I_{CCProgEE}$	Power Supply Current during EEPROM data Write / Erase		$0.7\text{ Freq (MHz)} + 3$	$0.7\text{ Freq (MHz)} + 18$	mA	$V_{CC} = 3.6\text{ V}^{(1)}$
I_{CCIDLE}	Power Supply Current on idle mode			$0.3\text{ Freq (MHz)} + 2$	mA	$V_{CC} = 3.6\text{ V}^{(2)}$

- Operating I_{CC} is measured with all output pins disconnected; XTAL1 driven with T_{CLCH} , $T_{CHCL} = 5\text{ ns}$ (see Figure 36.), $V_{IL} = V_{SS} + 0.5\text{ V}$, $V_{IH} = V_{CC} - 0.5\text{ V}$; XTAL2 N.C.; $\overline{\text{EA}} = \overline{\text{RST}} = \text{Port } 0 = V_{CC}$. I_{CC} would be slightly higher if a crystal oscillator used (see Figure 33.).
- Idle I_{CC} is measured with all output pins disconnected; XTAL1 driven with T_{CLCH} , $T_{CHCL} = 5\text{ ns}$, $V_{IL} = V_{SS} + 0.5\text{ V}$, $V_{IH} = V_{CC} - 0.5\text{ V}$; XTAL2 N.C.; Port 0 = V_{CC} ; $\overline{\text{EA}} = \overline{\text{RST}} = V_{SS}$ (see Figure 34.).
- Power Down I_{CC} is measured with all output pins disconnected; $\overline{\text{EA}} = V_{SS}$, PORT 0 = V_{CC} ; XTAL2 NC.; RST = V_{SS} (see Figure 35.). In addition, the WDT must be inactive and the POF flag must be set.
- Capacitance loading on Ports 0 and 2 may cause spurious noise pulses to be superimposed on the V_{OL} s of ALE and Ports 1 and 3. The noise is due to external bus capacitance discharging into the Port 0 and Port 2 pins when these pins make 1 to 0

transitions during bus operation. In the worst cases (capacitive loading 100pF), the noise pulse on the ALE line may exceed 0.45V with maxi V_{OL} peak 0.6V. A Schmitt Trigger use is not necessary.

8. Typicals are based on a limited number of samples and are not guaranteed. The values listed are at room temperature..
9. Under steady state (non-transient) conditions, I_{OL} must be externally limited as follows:

Maximum I_{OL} per port pin: 10 mA

Maximum I_{OL} per 8-bit port:

Port 0: 26 mA

Ports 1, 2 and 3: 15 mA

Maximum total I_{OL} for all output pins: 71 mA

If I_{OL} exceeds the test condition, V_{OL} may exceed the related specification. Pins are not guaranteed to sink current greater than the listed test conditions.

Figure 33. I_{CC} Test Condition, Active Mode

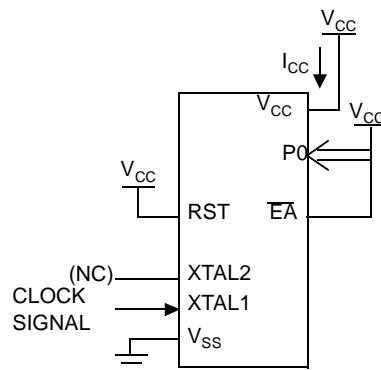

All other pins are disconnected.

Figure 34. I_{CC} Test Condition, Idle Mode

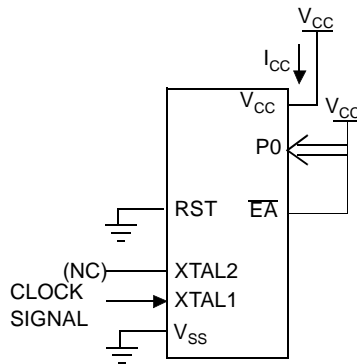

All other pins are disconnected.

Figure 35. I_{CC} Test Condition, Power-Down Mode

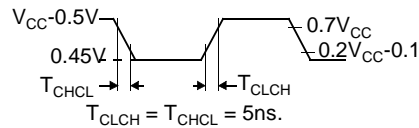
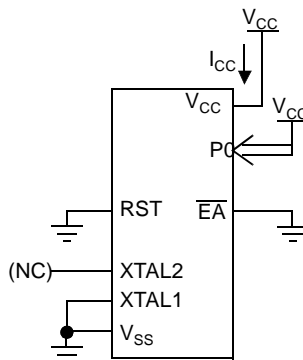

Figure 36. Clock Signal Waveform for I_{CC} Tests in Active and Idle Modes



All other pins are disconnected.

AC Parameters

Explanation of the AC Symbols

Each timing symbol has 5 characters. The first character is always a “T” (stands for time). The other characters, depending on their positions, stand for the name of a signal or the logical status of that signal. The following is a list of all the characters and what they stand for.

Example: T_{AVLL} = Time for Address Valid to ALE Low.

T_{LLPL} = Time for ALE Low to PSEN Low.

$T_A = 0$ to $+70^\circ\text{C}$; $V_{SS} = 0$ V; $V_{CC} = 5$ V \pm 10%; M range.

$T_A = -40^\circ\text{C}$ to $+85^\circ\text{C}$; $V_{SS} = 0$ V; $V_{CC} = 5$ V \pm 10%; M range.

$T_A = 0$ to $+70^\circ\text{C}$; $V_{SS} = 0$ V; 2.7 V $< V_{CC} < 3.3$ V; L range.

$T_A = -40^\circ\text{C}$ to $+85^\circ\text{C}$; $V_{SS} = 0$ V; 2.7 V $< V_{CC} < 3.3$ V; L range.

AC characteristics of -M parts at 3 volts are similar to -L parts

(Load Capacitance for port 0, ALE and PSEN = 100 pF; Load Capacitance for all other outputs = 80 pF.)

Table 44, Table 48 and Table 50 give the description of each AC symbols.

Table 46, Table 49 and Table 51 give for each range the AC parameter.

Table 47, Table 50 and Table 52 give the frequency derating formula of the AC parameter for each speed range description. To calculate each AC symbols. take the x value in the corresponding column (-M or -L) and use this value in the formula.

Example: T_{LLIU} for -M and 20 MHz, Standard clock.

$x = 35$ ns

$T = 50$ ns

$T_{CCIV} = 4T - x = 165$ ns

External Program Memory Characteristics

Symbol	Parameter
T	Oscillator clock period
T _{LHLL}	ALE pulse width
T _{AVLL}	Address Valid to ALE
T _{LLAX}	Address Hold After ALE
T _{LLIV}	ALE to Valid Instruction In
T _{LLPL}	ALE to $\overline{\text{PSEN}}$
T _{PLPH}	$\overline{\text{PSEN}}$ Pulse Width
T _{PLIV}	$\overline{\text{PSEN}}$ to Valid Instruction In
T _{PXIX}	Input Instruction Hold After $\overline{\text{PSEN}}$
T _{PXIZ}	Input Instruction Float After $\overline{\text{PSEN}}$
T _{AVIV}	Address to Valid Instruction In
T _{PLAZ}	$\overline{\text{PSEN}}$ Low to Address Float

Table 46. AC Parameters for a Fix Clock

Symbol	-M		-L		Units
	Min	Max	Min	Max	
T	25		25		ns
T _{LHLL}	40		40		ns
T _{AVLL}	10		10		ns
T _{LLAX}	10		10		ns
T _{LLIV}		70		70	ns
T _{LLPL}	15		15		ns
T _{PLPH}	55		55		ns
T _{PLIV}		35		35	ns
T _{PXIX}	0		0		ns
T _{PXIZ}		18		18	ns
T _{AVIV}		85		85	ns
T _{PLAZ}		10		10	ns

Table 47. AC Parameters for a Variable Clock

Symbol	Type	Standard Clock	X2 Clock	X parameter for - M range	X parameter for - L range	Units
T_{LHLL}	Min	$2 T - x$	$T - x$	10	10	ns
T_{AVLL}	Min	$T - x$	$0.5 T - x$	15	15	ns
T_{LLAX}	Min	$T - x$	$0.5 T - x$	15	15	ns
T_{LLIV}	Max	$4 T - x$	$2 T - x$	30	30	ns
T_{LLPL}	Min	$T - x$	$0.5 T - x$	10	10	ns
T_{PLPH}	Min	$3 T - x$	$1.5 T - x$	20	20	ns
T_{PLIV}	Max	$3 T - x$	$1.5 T - x$	40	40	ns
T_{PXIX}	Min	x	x	0	0	ns
T_{PXIZ}	Max	$T - x$	$0.5 T - x$	7	7	ns
T_{AVIV}	Max	$5 T - x$	$2.5 T - x$	40	40	ns
T_{PLAZ}	Max	x	x	10	10	ns

External Program Memory Read Cycle

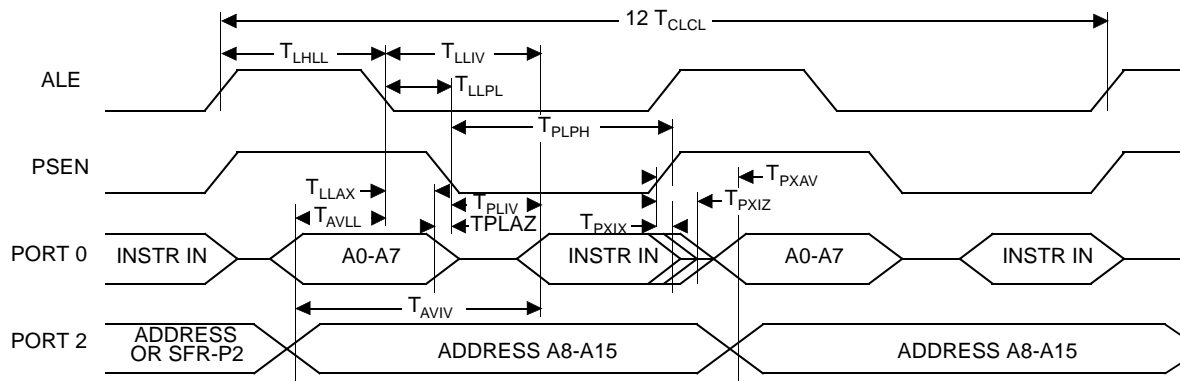

External Data Memory Characteristics

Table 48. Symbol Description

Symbol	Parameter
T_{RLRH}	\overline{RD} Pulse Width
T_{WLWH}	\overline{WR} Pulse Width
T_{RLDV}	\overline{RD} to Valid Data In
T_{RHDX}	Data Hold After \overline{RD}
T_{RHDZ}	Data Float After \overline{RD}
T_{LLDV}	ALE to Valid Data In
T_{AVDV}	Address to Valid Data In
T_{LLWL}	ALE to \overline{WR} or \overline{RD}
T_{AVWL}	Address to \overline{WR} or \overline{RD}
T_{QVWX}	Data Valid to \overline{WR} Transition
T_{QVWH}	Data set-up to \overline{WR} High
T_{WHQX}	Data Hold After \overline{WR}
T_{RLAZ}	\overline{RD} Low to Address Float
T_{WHLH}	\overline{RD} or \overline{WR} High to ALE high

Table 49. AC Parameters for a Fix Clock

Symbol	-M		-L		Units
	Min	Max	Min	Max	
T_{RLRH}	130		130		ns
T_{WLWH}	130		130		ns
T_{RLDV}		100		100	ns
T_{RHDX}	0		0		ns
T_{RHDZ}		30		30	ns
T_{LLDV}		160		160	ns
T_{AVDV}		165		165	ns
T_{LLWL}	50	100	50	100	ns
T_{AVWL}	75		75		ns
T_{QVWX}	10		10		ns
T_{QVWH}	160		160		ns
T_{WHQX}	15		15		ns
T_{RLAZ}		0		0	ns
T_{WHLH}	10	40	10	40	ns

Table 50. AC Parameters for a Variable Clock

Symbol	Type	Standard Clock	X2 Clock	X parameter for - M range	X parameter for - L range	Units
T_{RLRH}	Min	$6 T - x$	$3 T - x$	20	20	ns
T_{WLWH}	Min	$6 T - x$	$3 T - x$	20	20	ns
T_{RLDV}	Max	$5 T - x$	$2.5 T - x$	25	25	ns
T_{RHDX}	Min	x	x	0	0	ns
T_{RHDZ}	Max	$2 T - x$	$T - x$	20	20	ns
T_{LLDV}	Max	$8 T - x$	$4 T - x$	40	40	ns
T_{AVDV}	Max	$9 T - x$	$4.5 T - x$	60	60	ns
T_{LLWL}	Min	$3 T - x$	$1.5 T - x$	25	25	ns
T_{LLWL}	Max	$3 T + x$	$1.5 T + x$	25	25	ns
T_{AVWL}	Min	$4 T - x$	$2 T - x$	25	25	ns
T_{QVWX}	Min	$T - x$	$0.5 T - x$	15	15	ns
T_{QVWH}	Min	$7 T - x$	$3.5 T - x$	15	15	ns
T_{WHQX}	Min	$T - x$	$0.5 T - x$	10	10	ns
T_{RLAZ}	Max	x	x	0	0	ns
T_{WHLH}	Min	$T - x$	$0.5 T - x$	15	15	ns
T_{WHLH}	Max	$T + x$	$0.5 T + x$	15	15	ns

External Data Memory Write Cycle

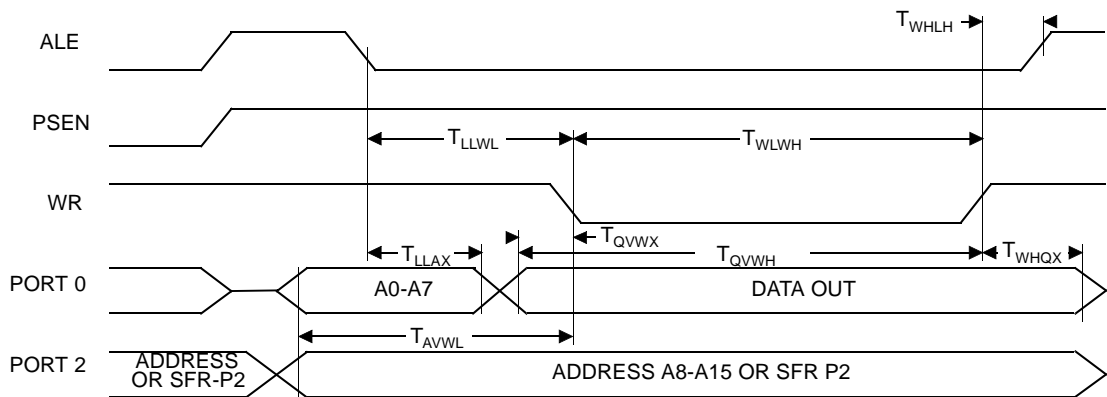

External Data Memory Read Cycle

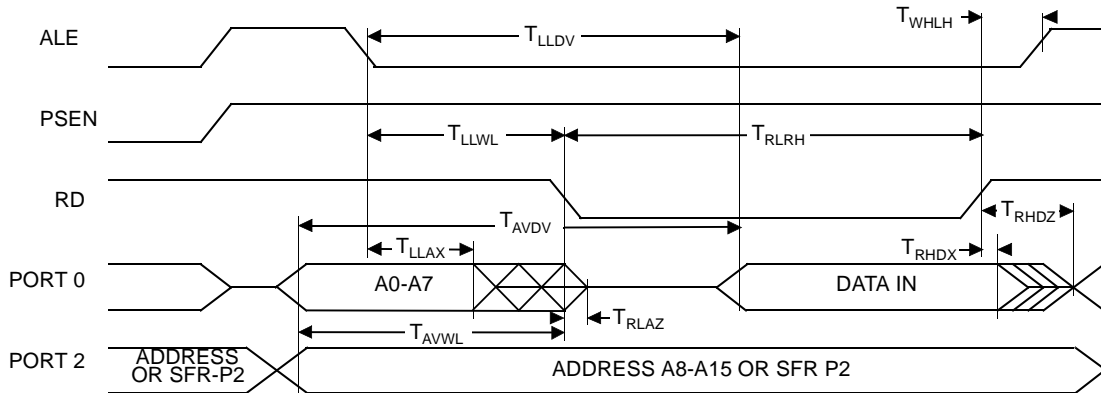

Serial Port Timing - Shift Register Mode

Symbol	Parameter
T_{XLXL}	Serial port clock cycle time
T_{QVHX}	Output data set-up to clock rising edge
T_{XHGX}	Output data hold after clock rising edge
T_{XHDX}	Input data hold after clock rising edge
T_{XHDV}	Clock rising edge to input data valid

Table 51. AC Parameters for a Fix Clock

Symbol	-M		-L		Units
	Min	Max	Min	Max	
T_{XLXL}	300		300		ns
T_{QVHX}	200		200		ns
T_{XHGX}	30		30		ns
T_{XHDX}	0		0		ns
T_{XHDV}		117		117	ns

Table 52. AC Parameters for a Variable Clock

Symbol	Type	Standard Clock	X2 Clock	X parameter for - M range	X parameter for - L range	Units
T_{XLXL}	Min	12 T	6 T			ns
T_{QVHX}	Min	10 T - x	5 T - x	50	50	ns
T_{XHGX}	Min	2 T - x	T - x	20	20	ns
T_{XHDX}	Min	x	x	0	0	ns
T_{XHDV}	Max	10 T - x	5 T - x	133	133	ns

Shift Register Timing Waveforms

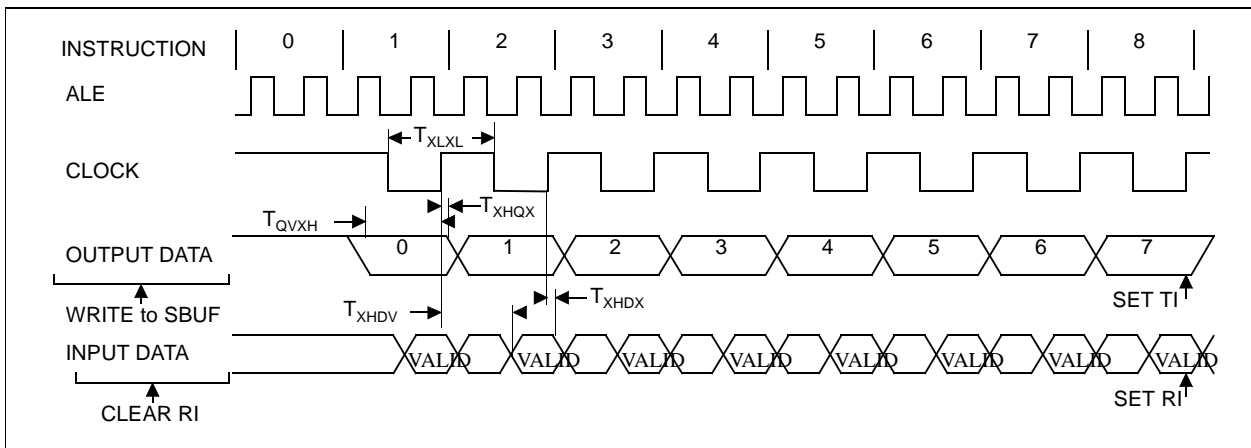

Flash EEPROM Programming and Verification Characteristics $T_A = 21^\circ\text{C}$ to 27°C ; $V_{SS} = 0\text{V}$; $V_{CC} = 5\text{V} \pm 10\%$.

Table 53. Flash Programming Parameters

Symbol	Parameter	Min	Max	Units
$1/T_{CLCL}$	Oscillator Frequency	4	6	MHz
T_{EHAZ}	Control to address float		$48 T_{CLCL}$	
T_{AVGL}	Address Setup to $\overline{\text{PROG}}$ Low	$48 T_{CLCL}$		
T_{GHAX}	Address Hold after $\overline{\text{PROG}}$	$48 T_{CLCL}$		
T_{DVGL}	Data Setup to $\overline{\text{PROG}}$ Low	$48 T_{CLCL}$		
T_{GHDX}	Data Hold after $\overline{\text{PROG}}$	$48 T_{CLCL}$		
T_{GLGH}	$\overline{\text{PROG}}$ Width for PGMC and PGXC*	10	20	ms
T_{GLGH}	$\overline{\text{PROG}}$ Width for PGML	$48 T_{CLCL}$		
T_{AVQV}	Address to Valid Data		$48 T_{CLCL}$	
T_{ELQV}	ENABLE Low to Data Valid		$48 T_{CLCL}$	
T_{EHQZ}	Data Float after ENABLE	0	$48 T_{CLCL}$	

Flash EEPROM Programming and Verification Waveforms

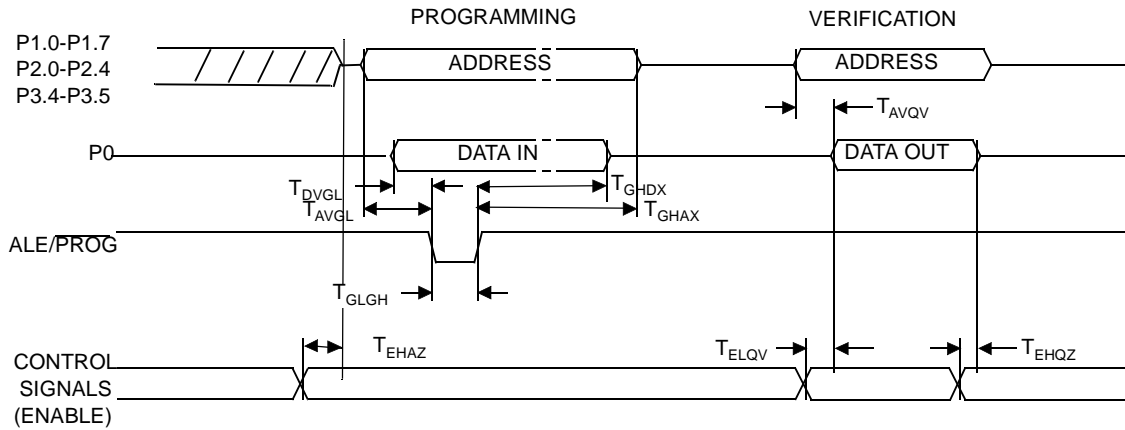

External Clock Drive Characteristics (XTAL1)

Table 54. AC Parameters

Symbol	Parameter	Min	Max	Units
T_{CLCL}	Oscillator Period	25		ns
T_{CHCX}	High Time	5		ns
T_{CLCX}	Low Time	5		ns
T_{CLCH}	Rise Time		5	ns
T_{CHCL}	Fall Time		5	ns
T_{CHCX}/T_{CLCX}	Cyclic ratio in X2 mode	40	60	%

External Clock Drive Waveforms

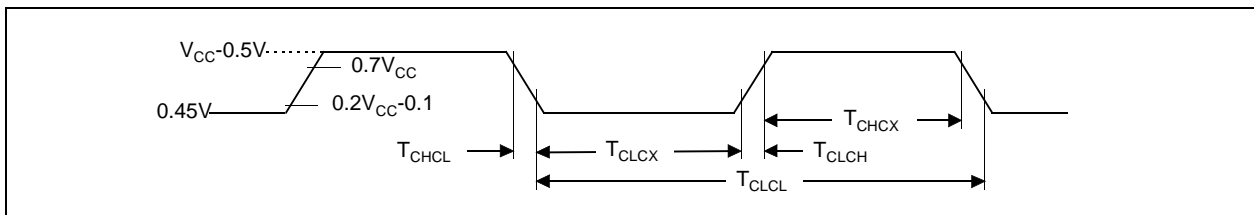

AC Testing Input/Output Waveforms

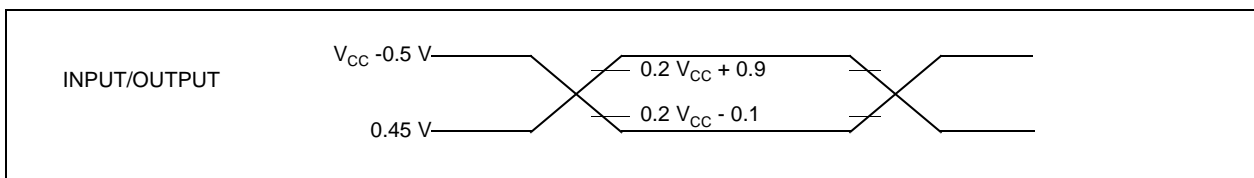

AC inputs during testing are driven at $V_{CC} - 0.5$ for a logic "1" and $0.45V$ for a logic "0". Timing measurement are made at V_{IH} min for a logic "1" and V_{IL} max for a logic "0".

Float Waveforms

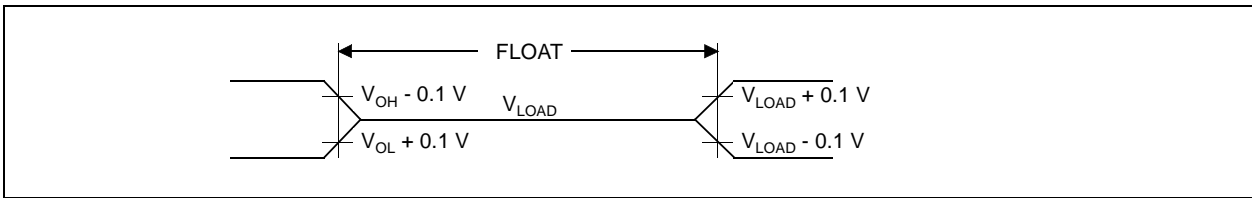

For timing purposes as port pin is no longer floating when a 100 mV change from load voltage occurs and begins to float when a 100 mV change from the loaded V_{OH}/V_{OL} level occurs. $I_{OL}/I_{OH} \geq \pm 20mA$.

Clock Waveforms

Valid in normal clock mode. In X2 mode XTAL2 must be changed to XTAL2/2.

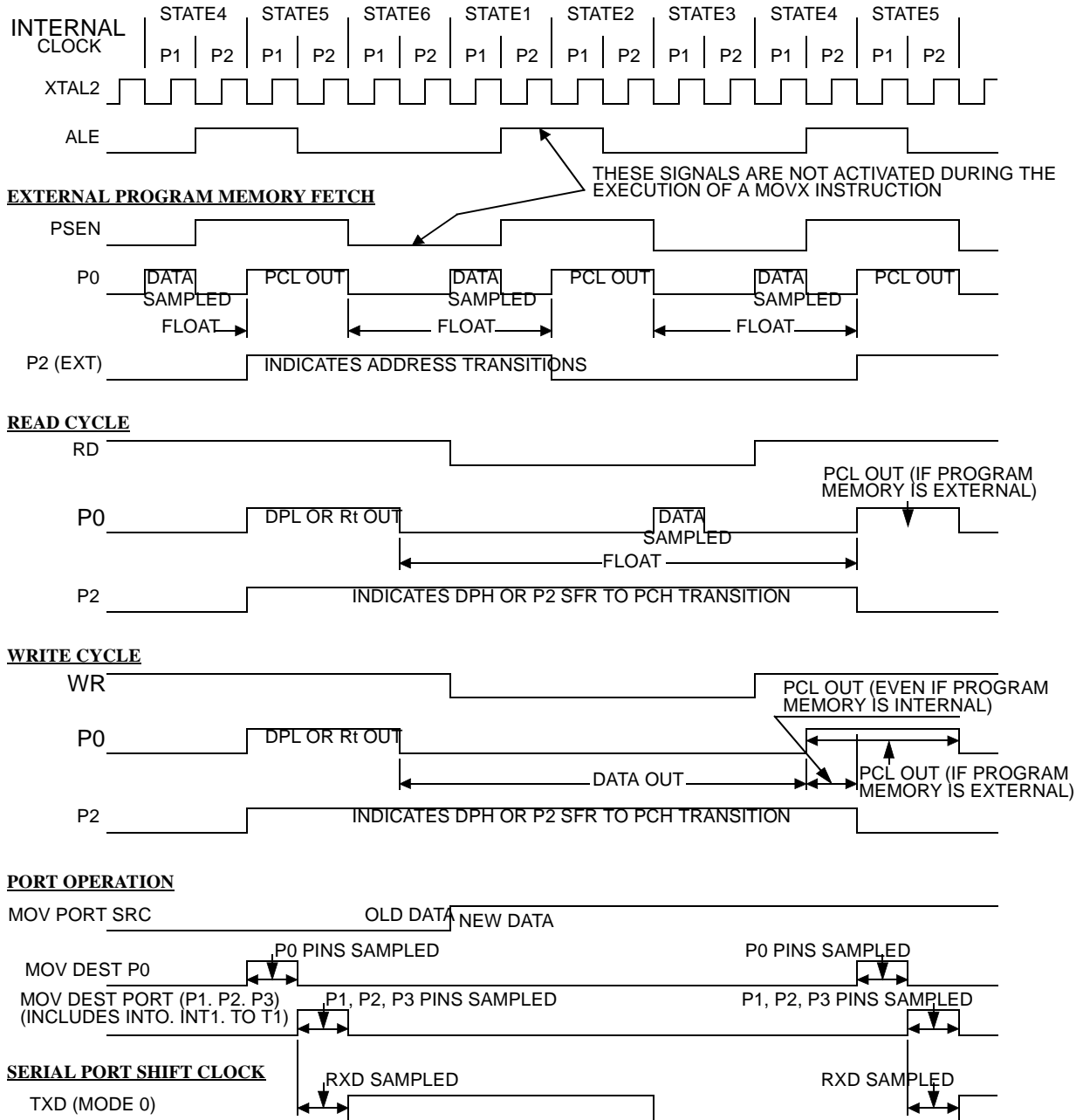

This diagram indicates when signals are clocked internally. The time it takes the signals to propagate to the pins, however, ranges from 25 to 125 ns. This propagation delay is dependent on variables such as temperature and pin loading. Propagation also varies from output to output and component. Typically though ($T_A=25^\circ\text{C}$ fully loaded) $\overline{\text{RD}}$ and $\overline{\text{WR}}$ propagation delays are approximately 50ns. The other signals are typically 85 ns. Propagation delays are incorporated in the AC specifications.

Ordering Information

Part Number	Memory Size	Supply Voltage	Temperature Range	Package	Packing
T89C51RD2-3CSCL	64 Kbytes	2.7 - 3.6V	Commercial	PDIL40	Stick
T89C51RD2-3CSCM	64 Kbytes	4.5 - 5.5V	Commercial	PDIL40	Stick
T89C51RD2-3CSIL	64 Kbytes	2.7 - 3.6V	Industrial	PDIL40	Stick
T89C51RD2-3CSIM	64 Kbytes	4.5 - 5.5V	Industrial	PDIL40	Stick
T89C51RD2-DDVCM	64 Kbytes	4.5 - 5.5V	Commercial	Dice	Tray & Dry Pack
T89C51RD2-RDTCL	64 Kbytes	2.7 - 3.6V	Commercial	VQFP64	Tray
T89C51RD2-RDTCM	64 Kbytes	4.5 - 5.5V	Commercial	VQFP64	Tray
T89C51RD2-RDTIL	64 Kbytes	2.7 - 3.6V	Industrial	VQFP64	Tray
T89C51RD2-RDTIM	64 Kbytes	4.5 - 5.5V	Industrial	VQFP64	Tray
T89C51RD2-RDVIM	64 Kbytes	4.5 - 5.5V	Industrial	VQFP64	Tray + Dry Pack
T89C51RD2-RLFCM	64 Kbytes	4.5 - 5.5V	Commercial	VQFP44	Tape & Reel + Dry Pack
T89C51RD2-RLFIM	64 Kbytes	4.5 - 5.5V	Industrial	VQFP44	Tape & Reel + Dry Pack
T89C51RD2-RLRIM	64 Kbytes	4.5 - 5.5V	Industrial	VQFP44	Tape & Reel
T89C51RD2-RLTCL	64 Kbytes	2.7 - 3.6V	Commercial	VQFP44	Tray
T89C51RD2-RLTCM	64 Kbytes	4.5 - 5.5V	Commercial	VQFP44	Tray
T89C51RD2-RLTIL	64 Kbytes	2.7 - 3.6V	Industrial	VQFP44	Tray
T89C51RD2-RLTIM	64 Kbytes	4.5 - 5.5V	Industrial	VQFP44	Tray
T89C51RD2-RLVCL	64 Kbytes	2.7 - 3.6V	Commercial	VQFP44	Tray + Dry Pack
T89C51RD2-RLVCM	64 Kbytes	4.5 - 5.5V	Commercial	VQFP44	Tray + Dry Pack
T89C51RD2-RLVIL	64 Kbytes	2.7 - 3.6V	Industrial	VQFP44	Tray + Dry Pack
T89C51RD2-RLVIM	64 Kbytes	4.5 - 5.5V	Industrial	VQFP44	Tray + Dry Pack
T89C51RD2-SLFCL	64 Kbytes	2.7 - 3.6V	Commercial	PLC44	Tape & Reel + Dry Pack
T89C51RD2-SLRCM	64 Kbytes	4.5 - 5.5V	Commercial	PLC44	Tape & Reel
T89C51RD2-SLRIM	64 Kbytes	4.5 - 5.5V	Industrial	PLC44	Tape & Reel
T89C51RD2-SLSCL	64 Kbytes	2.7 - 3.6V	Commercial	PLC44	Stick
T89C51RD2-SLSCM	64 Kbytes	4.5 - 5.5V	Commercial	PLC44	Stick
T89C51RD2-SLSIL	64 Kbytes	2.7 - 3.6V	Industrial	PLC44	Stick
T89C51RD2-SLSIM	64 Kbytes	4.5 - 5.5V	Industrial	PLC44	Stick
T89C51RD2-SLUCM	64 Kbytes	4.5 - 5.5V	Commercial	PLC44	Stick + Dry Pack
T89C51RD2-SLUIM	64 Kbytes	4.5 - 5.5V	Industrial	PLC44	Stick + Dry Pack
T89C51RD2-SMRIL	64 Kbytes	2.7 - 3.6V	Industrial	PLCC68	Tape & Reel





Part Number	Memory Size	Supply Voltage	Temperature Range	Package	Packing
T89C51RD2-SMSCL	64 Kbytes	2.7 - 3.6V	Commercial	PLCC68	Stick
T89C51RD2-SMSCM	64 Kbytes	4.5 - 5.5V	Commercial	PLCC68	Stick
T89C51RD2-SMSIL	64 Kbytes	2.7 - 3.6V	Industrial	PLCC68	Stick
T89C51RD2-SMSIM	64 Kbytes	4.5 - 5.5V	Industrial	PLCC68	Stick
T89C51RD2-SMUJCM	64 Kbytes	4.5 - 5.5V	Commercial	PLCC68	Stick + Dry Pack
T89C51RD2-SMUJIM	64 Kbytes	4.5 - 5.5V	Industrial	PLCC68	Stick + Dry Pack

Package Drawings

DIL40

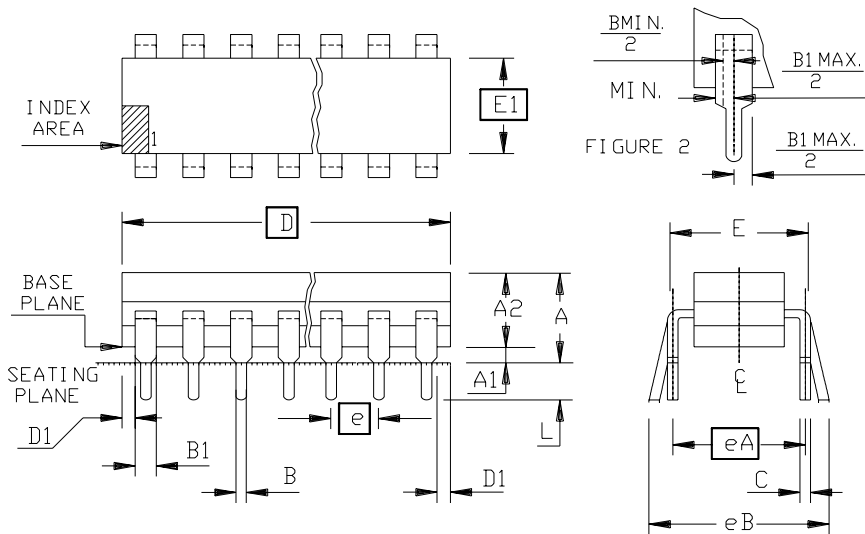

	MM		INCH	
A	-	5.08	-	.200
A1	0.38	-	.015	-
A2	3.18	4.95	.125	.195
B	0.36	0.56	.014	.022
B1	0.76	1.78	.030	.070
C	0.20	0.38	.008	.015
D	50.29	53.21	1.980	2.095
E	15.24	15.87	.600	.625
E1	12.32	14.73	.485	.580
e	2.54	B. S. C	.100	B. S. C
eA	15.24	B. S. C	.600	B. S. C
eB	-	17.78	-	.700
L	2.93	3.81	.115	.150
D1	0.13	-	.005	-

PLCC44

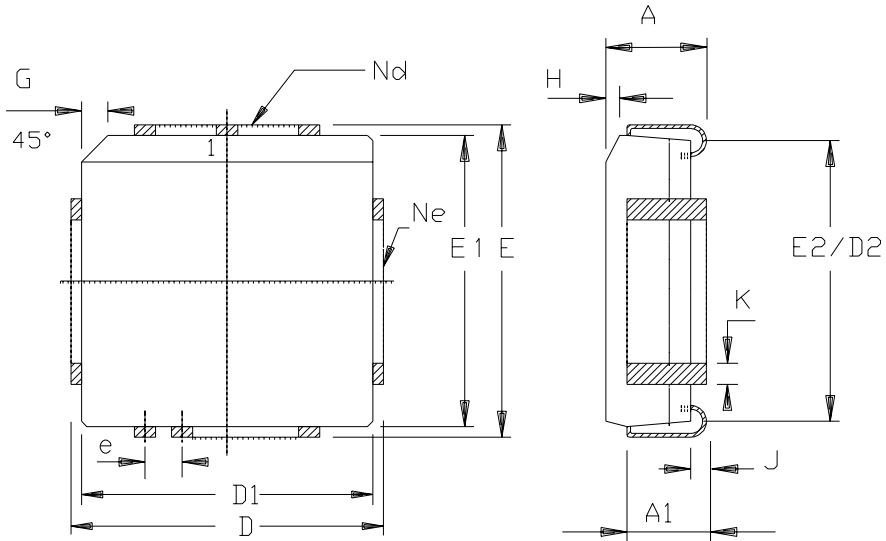

	MM		INCH	
A	4.20	4.57	.165	.180
A1	2.29	3.04	.090	.120
D	17.40	17.65	.685	.695
D1	16.44	16.66	.647	.656
D2	14.99	16.00	.590	.630
E	17.40	17.65	.685	.695
E1	16.44	16.66	.647	.656
E2	14.99	16.00	.590	.630
e	1.27	BSC	.050	BSC
G	1.07	1.22	.042	.048
H	1.07	1.42	.042	.056
J	0.51	-	.020	-
K	0.33	0.53	.013	.021
Nd	11		11	
Ne	11		11	

VQFP44

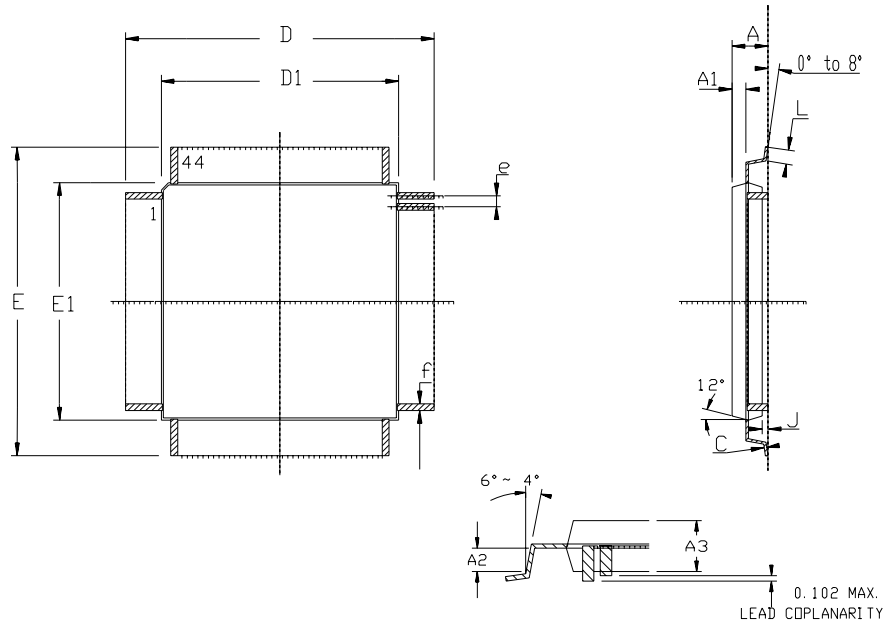

	MM		INCH	
	Min	Max	Min	Max
A	-	1.60	-	.063
A1	0.64 REF		.025 REF	
A2	0.64 REF		.025 REF	
A3	1.35	1.45	.053	.057
D	11.90	12.10	.468	.476
D1	9.90	10.10	.390	.398
E	11.90	12.10	.468	.476
E1	9.90	10.10	.390	.398
J	0.05	-	.002	-
L	0.45	0.75	.018	.030
e	0.80 BSC		.0315 BSC	
f	0.35 BSC		.014 BSC	

VQFP64

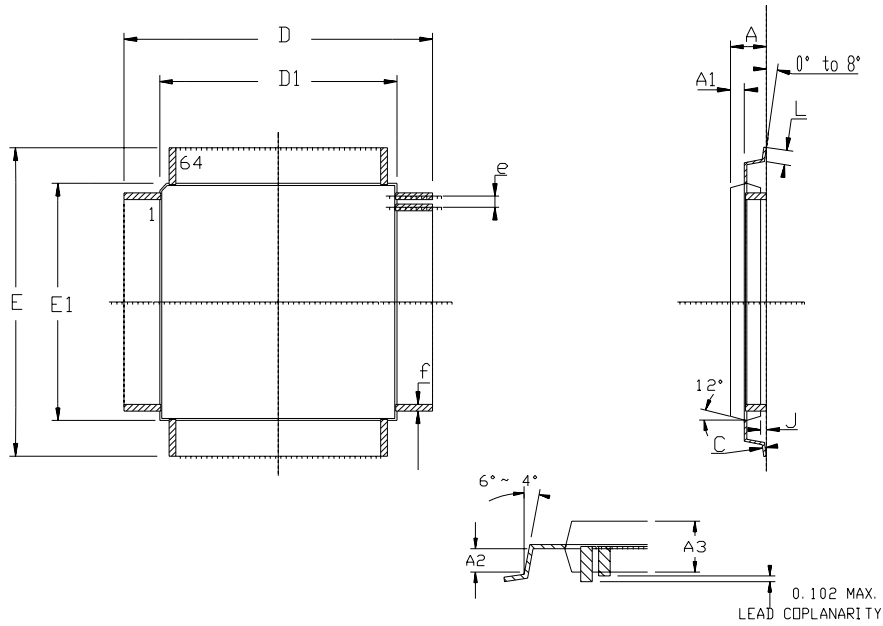

	MM		INCH	
	Min	Max	Min	Max
A	-	1.60	-	.063
A1	0.64 REF		.025 REF	
A2	0.64 REF		.025 REF	
A3	1.35	1.45	.053	.057
D	11.75	12.25	.463	.483
D1	9.90	10.10	.390	.398
E	11.75	12.25	.463	.483
E1	9.90	10.10	.390	.398
J	0.05	-	.002	-
L	0.45	0.75	.018	.030
e	0.50 BSC		.0197 BSC	
f	0.25 BSC		.010 BSC	

PLCC68

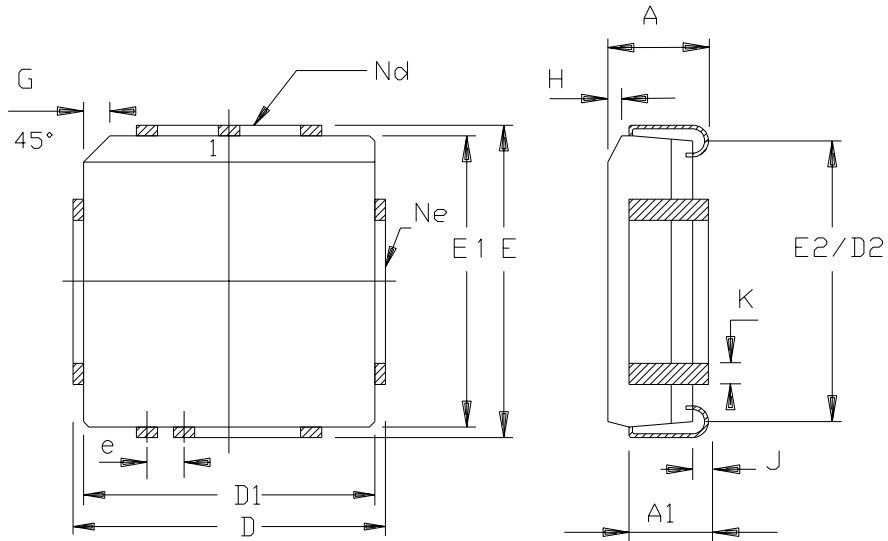

	MM		INCH	
	A	4.20	5.08	.165
A1	2.29	3.30	.090	.130
D	25.02	25.27	.985	.995
D1	24.13	24.33	.950	.958
D2	22.61	23.62	.890	.930
E	25.02	25.27	.985	.995
E1	24.13	24.33	.950	.958
E2	22.61	23.62	.890	.930
e	1.27	BSC	.050	BSC
G	1.07	1.22	.042	.048
H	1.07	1.42	.042	.056
J	0.51	-	.020	-
K	0.33	0.53	.013	.021
Nd	17		17	
Ne	17		17	
PKG STD	00			

VQFP64

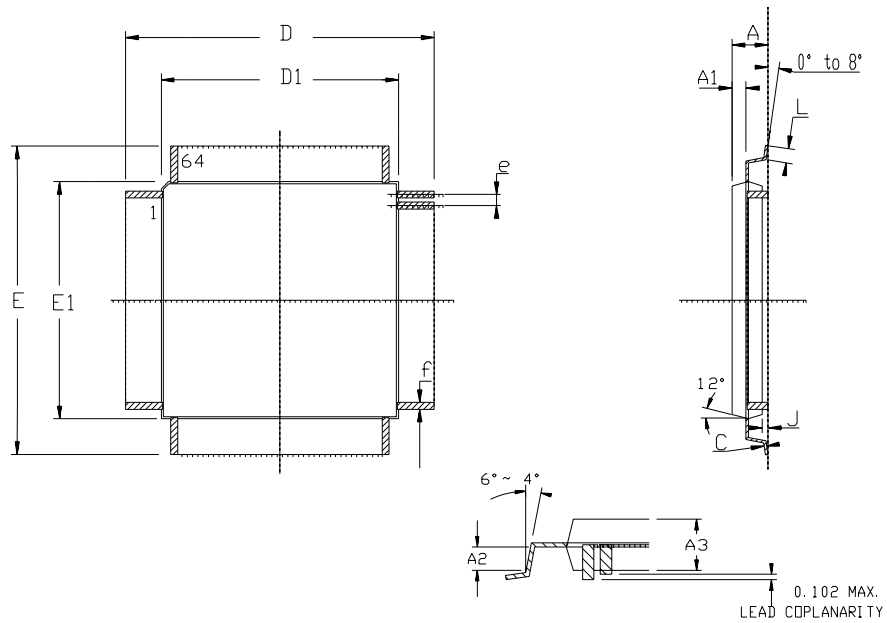

	MM		INCH	
	Min	Max	Min	Max
A	-	1.60	-	.063
A1	0.64 REF		.025 REF	
A2	0.64 REF		.025 REF	
A3	1.35	1.45	.053	.057
D	11.75	12.25	.463	.483
D1	9.90	10.10	.390	.398
E	11.75	12.25	.463	.483
E1	9.90	10.10	.390	.398
J	0.05	-	.002	-
L	0.45	0.75	.018	.030
e	0.50 BSC		.0197 BSC	
f	0.25 BSC		.010 BSC	

Datasheet Change Log for T89C51RD2

**Changes from 4243F-
02/01 to 4243G-05/03**

1. Added bootloader ISP protocol description.



Atmel Headquarters

Corporate Headquarters

2325 Orchard Parkway
San Jose, CA 95131
TEL 1(408) 441-0311
FAX 1(408) 487-2600

Europe

Atmel Sarl
Route des Arsenaux 41
Case Postale 80
CH-1705 Fribourg
Switzerland
TEL (41) 26-426-5555
FAX (41) 26-426-5500

Asia

Room 1219
Chinachem Golden Plaza
77 Mody Road Tsimhatsui
East Kowloon
Hong Kong
TEL (852) 2721-9778
FAX (852) 2722-1369

Japan

9F, Tonetsu Shinkawa Bldg.
1-24-8 Shinkawa
Chuo-ku, Tokyo 104-0033
Japan
TEL (81) 3-3523-3551
FAX (81) 3-3523-7581

Atmel Operations

Memory

2325 Orchard Parkway
San Jose, CA 95131
TEL 1(408) 441-0311
FAX 1(408) 436-4314

Microcontrollers

2325 Orchard Parkway
San Jose, CA 95131
TEL 1(408) 441-0311
FAX 1(408) 436-4314

La Chantrerie
BP 70602
44306 Nantes Cedex 3, France
TEL (33) 2-40-18-18-18
FAX (33) 2-40-18-19-60

ASIC/ASSP/Smart Cards

Zone Industrielle
13106 Rousset Cedex, France
TEL (33) 4-42-53-60-00
FAX (33) 4-42-53-60-01

1150 East Cheyenne Mtn. Blvd.
Colorado Springs, CO 80906
TEL 1(719) 576-3300
FAX 1(719) 540-1759

Scottish Enterprise Technology Park
Maxwell Building
East Kilbride G75 0QR, Scotland
TEL (44) 1355-803-000
FAX (44) 1355-242-743

RF/Automotive

Theresienstrasse 2
Postfach 3535
74025 Heilbronn, Germany
TEL (49) 71-31-67-0
FAX (49) 71-31-67-2340

1150 East Cheyenne Mtn. Blvd.
Colorado Springs, CO 80906
TEL 1(719) 576-3300
FAX 1(719) 540-1759

Biometrics/Imaging/Hi-Rel MPU/ High Speed Converters/RF Data- com

Avenue de Rochepleine
BP 123
38521 Saint-Egreve Cedex, France
TEL (33) 4-76-58-30-00
FAX (33) 4-76-58-34-80

e-mail

literature@atmel.com

Web Site

<http://www.atmel.com>

Disclaimer: Atmel Corporation makes no warranty for the use of its products, other than those expressly contained in the Company's standard warranty which is detailed in Atmel's Terms and Conditions located on the Company's web site. The Company assumes no responsibility for any errors which may appear in this document, reserves the right to change devices or specifications detailed herein at any time without notice, and does not make any commitment to update the information contained herein. No licenses to patents or other intellectual property of Atmel are granted by the Company in connection with the sale of Atmel products, expressly or by implication. Atmel's products are not authorized for use as critical components in life support devices or systems.

Atmel Corporation 2003. All rights reserved. Atmel, the Atmel logo, and combinations thereof are registered trademarks of Atmel Corporation or its subsidiaries. Other terms and product names in this document may be the trademarks of others.



Printed on recycled paper.