

Features

- 16-channel GPS Correlator
 - 8192 Search Bins with GPS Acquisition Accelerator
 - Accuracy: 2.5m CEP (2D, Stand Alone)
 - Time to First Fix: 34s (Cold Start)
 - Acquisition Sensitivity: –140 dBm (With External LNA)
 - Tracking Sensitivity: –150 dBm (With External LNA)
- Utilizes the ARM7TDMI® ARM® Thumb® Processor Core
 - High-performance 32-bit RISC Architecture
 - EmbeddedICE™ (In-Circuit Emulation)
- 128 Kbytes Internal RAM
- 384 Kbytes Internal ROM with u-blox GPS Firmware
- 1.5-bit ADC On-chip
- Single IF Architecture
- 2 External Interrupts
- 24 User-programmable I/O Lines
- 1 USB Device Port
 - Universal Serial Bus (USB) 2.0 Full-speed Device
 - Embedded USB V2.0 Full-speed Transceiver
- 2 USARTs
- Master/Slave SPI Interface
 - 4 External Slave Chip Selects
- Programmable Watchdog Timer
- Advanced Power Management Controller (APMC)
 - Geared Master Clock to Reduce Power Consumption
 - Sleep State with Disabled Master Clock
 - Hibernate State with 32.768 kHz Master Clock
- Real Time Clock (RTC)
- 1.8V to 3.3V User-definable IO Voltage for Several GPIOs with 5V Tolerance
- 4 KBytes of Battery Backup Memory
- 7 mm × 10 mm 96 Pin BGA Package, 0.8 mm Pitch, Pb-free, RoHS-compliant

Benefits

- Fully Integrated Design With Low BOM
- No External Flash Memory Required
- Requires Only a GPS XTAL, No TCXO
- Supports NMEA®, UBX Binary and RTCM Protocol for DGPS
- Supports SBAS (WAAS, EGNOS, MSAS)
- Up to 4Hz Update Rate
- Supports A-GPS (Aiding)
- Excellent Noise Performance



ANTARIS4 Single-chip GPS Receiver

ATR0630P1 Automotive

Summary

NOTE: This is a summary document. The complete document is available. For more information, please contact your local Atmel sales office.

4978AS-GPS-12/07



1. Description

The ATR0630P1 is a low-power, single-chip GPS receiver, especially designed to meet the requirements of mobile applications. It is based on Atmel[®]'s ANTARIS[®]4 technology and integrates an RF front-end, filtering, and a baseband processor in a single, tiny 7 mm × 10 mm 96 pin BGA package. Providing excellent RF performance with low noise figure and low power consumption.

Due to the fully integrated design, just an RF SAW filter, a GPS XTAL (no TCXO) and blocking capacitors are required to realize a stand-alone GPS functionality.

The ATR0630P1 includes a complete GPS firmware, licensed from u-blox AG, which performs the GPS operation, including tracking, acquisition, navigation and position data output. For normal PVT (Position/Velocity/Time) applications, there is no need for external Flash- or ROM-memory.

The firmware supports e.g. the NMEA protocol (2.1 and 2.3), a binary protocol for PVT data, configuration and debugging, the RTCM protocol for DGPS, SBAS (WAAS, EGNOS and MSAS) and A-GPS (aiding). It is also possible to store the configuration settings in an optional external EEPROM.

Due to the integrated ARM7TDMI processor and an intelligent radio architecture, the ATR0630P1 operates in a complete autonomous mode, utilizing on chip AGC in closed loop operation.

For maximum performance, we recommend to use the ATR0630P1 together with a low noise amplifier (e.g. ATR0610).

The ATR0630P1 supports assisted GPS.

2. Architectural Overview

2.1 Block Diagram

Figure 2-1. ATR0630P1 Block Diagram

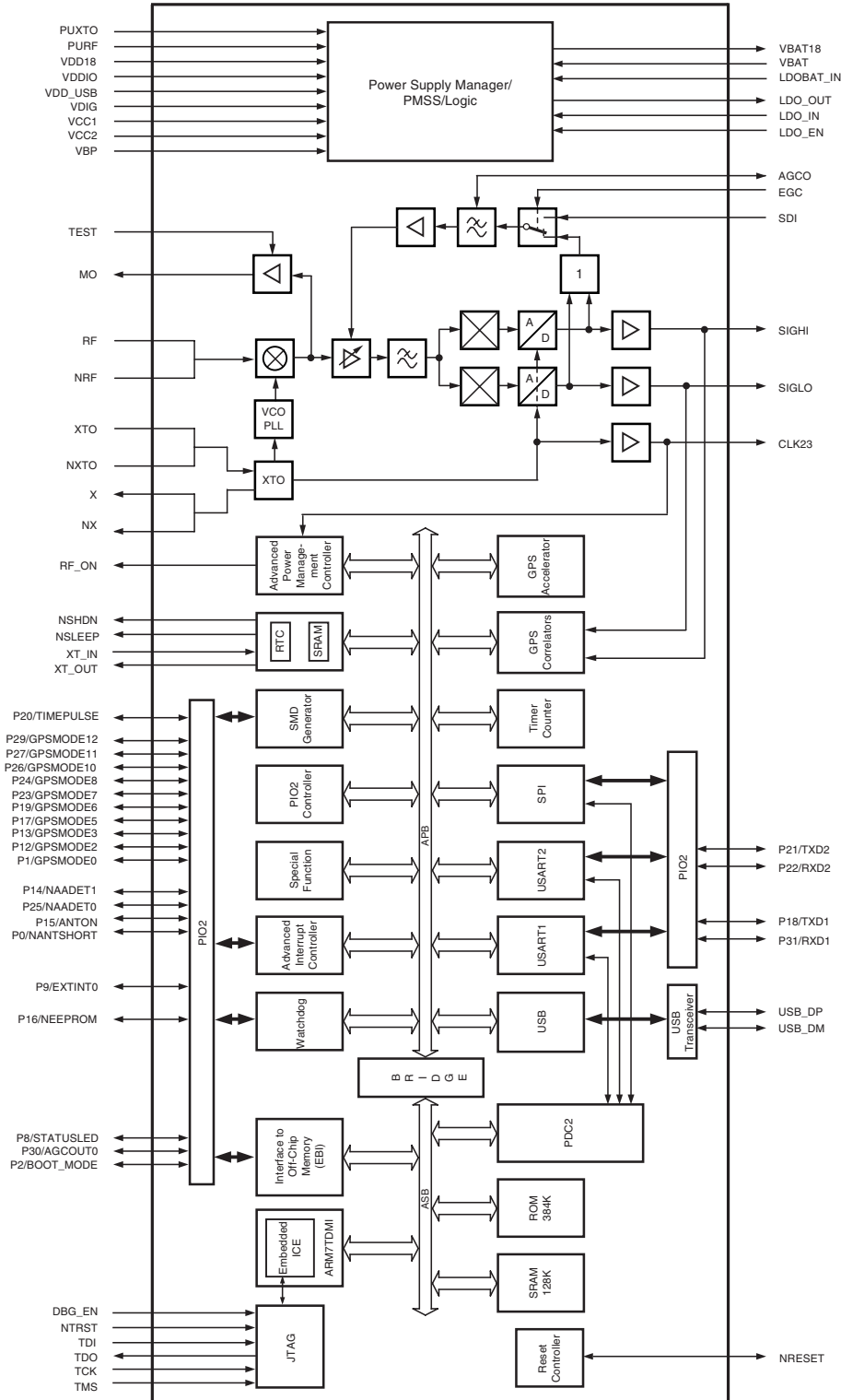

2.2 General Description

The ATR0630P1 has been designed especially for mobile applications. It provides high isolation between GPS and cellular bands, as well as very low power consumption.

ATR0630P1 is based on the successful ANTARIS4 technology which includes the ANTARIS ROM software, developed by u-blox AG, Switzerland. ANTARIS provides a proven navigation engine which is used in high-end car navigation systems, automatic vehicle location (AVL), security and surveying systems, traffic control, road pricing, and speed camera detectors, and provides location-based services (LBS) worldwide.

The ANTARIS4 chipset has a very low power consumption and comes with a very low BoM for the passive components. Especially, due to its fast search engine and GPS accelerator, the ATR0630P1 only needs a GPS crystal (XTAL) as a resonator for the integrated crystal oscillator of the ATR0630P1. This saves the considerable higher cost of a TCXO which is required for competitor's systems. Also, as the powerful standard software is available in ROM, no external flash memory is needed.

The L1 input signal (f_{RF}) is a Direct Sequence Spread Spectrum (DSSS) signal with a center frequency of 1575.42 MHz. The digital modulation scheme is Bi-Phase-Shift-Keying (BPSK) with a chip rate of 1.023 Mbps.

2.3 PMSS Logic

The power management, startup and shutdown (PMSS) logic ensures reliable operation within the recommended operating conditions. The external power control signals PUrf and PUxt are passed through Schmitt trigger inputs to eliminate voltage ripple and prevent undesired behavior during start-up and shut-down. Digital and analog supply voltages are analyzed by a monitoring circuit, enabling the startup of the IC only when it is within a safe operating range.

2.4 XTO

The XTO is designed for minimum phase noise and frequency perturbations. The balanced topology gives maximum isolation from external and ground coupled noise. The built-in jump start circuitry ensures reliable start-up behavior of any specified crystal. For use with an external TCXO, the XTO circuitry can be used as a single-ended or balanced input buffer.

The recommended reference frequency is: $f_{XTO} = 23.104$ MHz.

2.5 VCO/PLL

The frequency synthesizer features a balanced VCO and a fully integrated loop filter, thus no external components are required. The VCO combines very good phase noise behavior and excellent spurious suppression. The relation between the reference frequency (f_{XTO}) and the VCO center frequency (f_{VCO}) is given by: $f_{VCO} = f_{XTO} \times 64 = 23.104 \text{ MHz} \times 64 = 1478.656 \text{ MHz}$.

2.6 RF Mixer/Image Filter

Combined with the antenna, an external LNA provides a first band-path filtering of the signal. Atmel's ATR0610 is recommended for the LNA due to its low noise figure, high linearity and low power consumption. The output of the LNA drives a SAW filter, which provides image rejection for the mixer and the required isolation to all GSM bands. The output of the SAW filter is fed into a highly linear mixer with high conversion gain and excellent noise performance.

2.7 VGA/AGC

The on-chip automatic gain control (AGC) stage sets the gain of the VGA in order to optimally load the input of the following analog-to-digital converter. The AGC control loop can be selected for on-chip closed-loop operation or for baseband controlled gain mode.

2.8 Analog-to-digital Converter

The analog-to-digital converter stage has a total resolution of 1.5 bits. It comprises balanced comparators and a sub-sampling unit, clocked by the reference frequency (f_{XTO}). The frequency spectrum of the digital output signal (f_{OUT}), present at the data outputs SIGLO and SIGH1, is 4.348 MHz.

2.9 Baseband

The GPS baseband core includes a 16-channel correlator and is based on an ARM7TDMI ARM processor core with very low power consumption. It has a high-performance 32 bit RISC architecture, uses a high-density 16-bit instruction set, The ARM standard In-Circuit Emulation debug interface is supported via the JTAG/ICE port of the ATR0630P1.

The ATR0630P1 architecture consists of two main buses, the Advanced System Bus (ASB) and the Advanced Peripheral Bus (APB). The ASB is designed for maximum performance. It interfaces the processor with the on-chip 32-bit memories and the external memories and devices by means of the External Bus Interface (EBI). The APB is designed for accesses to on-chip peripherals and is optimized for low power consumption. The AMBA™ Bridge provides an interface between the ASB and the APB.

An on-chip Peripheral Data Controller (PDC2) transfers data between the on-chip USARTs/SPI and the on- and off-chip memories without processor intervention. Most importantly, the PDC2 removes the processor interrupt handling overhead and significantly reduces the number of clock cycles required for a data transfer. It can transfer up to 64K contiguous bytes without reprogramming the starting address. As a result, the performance of the microcontroller is increased and the power consumption reduced.

All of the external signals of the on-chip peripherals are under the control of the Parallel I/O Controller (PIO2). The PIO2 Controller can be programmed to insert an input filter on each pin or generate an interrupt on a signal change. After reset, the user must carefully program the PIO2 Controller in order to define which peripheral signals are connected with off-chip logic.

The ATR0630P1 features a Programmable Watchdog Timer.

An Advanced Power Management Controller (APMC) allows for the peripherals to be deactivated individually. Automatic master clock gearing reduces power consumption. A Sleep Mode is available with disabled 23.104 MHz master clock, as well as a Back-up Mode operating 32.768 kHz master clock.

A 32.768 kHz Real Time Clock (RTC), together with a built-in battery back-up SRAM, allows for storage of Almanac, Ephemeris, software configurations to make quick hot- and warm starts.

The ATR0630P1 includes full GPS firmware, licensed from u-blox AG, Switzerland. Features of the ROM firmware are described in software documentation available from u-blox AG, Switzerland.

3. Pin Configuration

3.1 Pinout

Figure 3-1. Pinning BGA96 (Top View)

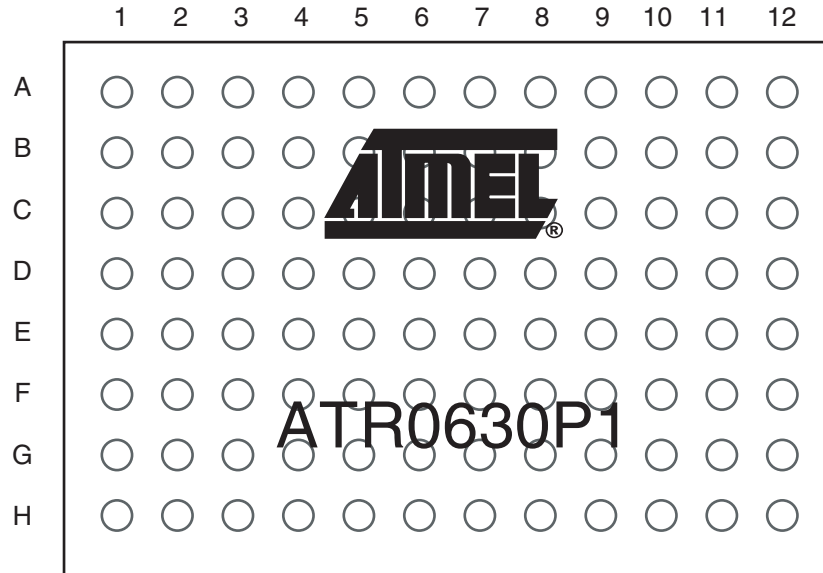

Table 3-1. ATR0630P1 Pinout

Pin Name	BGA 96	Pin Type	Pull Resistor (Reset Value) ⁽¹⁾	Firmware Label	PIO Bank A	
					I	O
AGCO	A4	Analog I/O				
CLK23	A8	Digital OUT				
DBG_EN	E8	Digital IN	PD			
EGC	D4	Digital IN				
GDIG	C5	Supply				
GND	A6	Supply				
GND	A9	Supply				
GND	B11	Supply				
GND	F5	Supply				
GND	H8	Supply				
GND	H12	Supply				
GND A	A3	Supply				
GND A	B1	Supply				

- Notes:
1. PD = internal pull-down resistor, PU = internal pull-up resistor, OH = switched to Output High at reset
 2. VBAT18 represent the internal power supply of the backup power domain.
 3. VDD_USB is the supply voltage for following the USB pins: USB_DM and USB_DP. For operation of the USB interface, supply of 3.0V to 3.6V is required.
 4. VDDIO is the supply voltage for the following GPIO pins: P1, P2, P8, P12, P14, P16, P17, P18, P19, P20, P21, P23, P24, P25, P26, P27 and P29.

Table 3-1. ATR0630P1 Pinout (Continued)

Pin Name	BGA 96	Pin Type	Pull Resistor (Reset Value) ⁽¹⁾	Firmware Label	PIO Bank A	
					I	O
GNDA	B4	Supply				
GNDA	D2	Supply				
GNDA	E1	Supply				
GNDA	E2	Supply				
GNDA	E3	Supply				
GNDA	F1	Supply				
GNDA	F2	Supply				
GNDA	F3	Supply				
GNDA	G1	Supply				
GNDA	H1	Supply				
LDOBAT_IN	D11	Supply				
LDO_EN	C11	Digital IN				
LDO_IN	E11	Supply				
LDO_OUT	E12	Supply				
MO	C3	Analog OUT				
NRESET	A7	Digital I/O	Open Drain PU			
NRF	C1	Analog IN				
NSHDN	E9	Digital OUT				
NSLEEP	E10	Digital OUT				
NTRST	H11	Digital IN	PD			
NX	B2	Analog OUT				
NXTO	B3	Analog IN				
P0	C8	Digital I/O	PD	NANTSHORT		
P1	D8	Digital I/O	Configurable (PD)	GPSMODE0		
P2	C6	Digital I/O	Configurable (PD)	BOOT_MODE		'0'
P8	D7	Digital I/O	Configurable (PD)	STATUSLED		'0'
P9	A11	Digital I/O	PU to VBAT18	EXTINT0	EXTINT0	
P12	D6	Digital I/O	Configurable (PU)	GPSMODE2		NPCS2
P13	B10	Digital I/O	PU to VBAT18	GPSMODE3	EXTINT1	
P14	G6	Digital I/O	Configurable (PD)	NAADET1		'0'
P15	F11	Digital I/O	PD	ANTON		
P16	G8	Digital I/O	Configurable (PU)	NEEPROM		
P17	H6	Digital I/O	Configurable (PD)	GPSMODE5	SCK1	SCK1
P18	C7	Digital I/O	Configurable (PU)	TXD1		TXD1
P19	F6	Digital I/O	Configurable (PU)	GPSMODE6		

- Notes:
1. PD = internal pull-down resistor, PU = internal pull-up resistor, OH = switched to Output High at reset
 2. VBAT18 represent the internal power supply of the backup power domain.
 3. VDD_USB is the supply voltage for following the USB pins: USB_DM and USB_DP. For operation of the USB interface, supply of 3.0V to 3.6V is required.
 4. VDDIO is the supply voltage for the following GPIO pins: P1, P2, P8, P12, P14, P16, P17, P18, P19, P20, P21, P23, P24, P25, P26, P27 and P29.





Table 3-1. ATR0630P1 Pinout (Continued)

Pin Name	BGA 96	Pin Type	Pull Resistor (Reset Value) ⁽¹⁾	Firmware Label	PIO Bank A	
					I	O
P20	G7	Digital I/O	Configurable (PD)	TIMEPULSE	SCK2	SCK2
P21	E6	Digital I/O	Configurable (PU)	TXD2		TXD2
P22	D10	Digital I/O	PU to VBAT18	RXD2	RXD2	
P23	F8	Digital I/O	Configurable (PU)	GPSMODE7	SCK	SCK
P24	H7	Digital I/O	Configurable (PU)	GPSMODE8	MOSI	MOSI
P25	G5	Digital I/O	Configurable (PD)	NAADET0	MISO	MISO
P26	B6	Digital I/O	Configurable (PU)	GPSMODE10	NSS	NPCS0
P27	F7	Digital I/O	Configurable (PU)	GPSMODE11		NPCS1
P28	E7	Digital I/O	OH			
P29	D5	Digital I/O	Configurable (PU)	GPSMODE12		NPCS3
P30	G12	Digital I/O	PD	AGCOUT0		AGCOUT0
P31	C10	Digital I/O	PU to VBAT18	RXD1	RXD1	
PURF	G4	Digital IN				
PURF	H4	Digital IN				
PUXTO	F4	Digital IN				
RF	D1	Analog IN				
RF_ON	F10	Digital OUT	PD			
SDI	C4	Digital IN				
SIGHI0	B8	Digital OUT				
SIGLO0	B7	Digital OUT				
TCK	G9	Digital IN	PU			
TDI	H10	Digital IN	PU			
TDO	F9	Digital OUT				
TEST	D3	Analog IN				
TMS	G10	Digital IN	PU			
USB_DM	D9	Digital I/O				
USB_DP	C9	Digital I/O				
VBAT	D12	Supply				
VBAT18 ⁽²⁾	C12	Supply				
VBP	G2	Supply				
VBP	G3	Supply				
VBP	H2	Supply				
VBP	H3	Supply				
VCC1	C2	Supply				
VCC2	E4	Supply				

- Notes:
1. PD = internal pull-down resistor, PU = internal pull-up resistor, OH = switched to Output High at reset
 2. VBAT18 represent the internal power supply of the backup power domain.
 3. VDD_USB is the supply voltage for following the USB pins: USB_DM and USB_DP. For operation of the USB interface, supply of 3.0V to 3.6V is required.
 4. VDDIO is the supply voltage for the following GPIO pins: P1, P2, P8, P12, P14, P16, P17, P18, P19, P20, P21, P23, P24, P25, P26, P27 and P29.

Table 3-1. ATR0630P1 Pinout (Continued)

Pin Name	BGA 96	Pin Type	Pull Resistor (Reset Value) ⁽¹⁾	Firmware Label	PIO Bank A	
					I	O
VDD_USB ⁽³⁾	A10	Supply				
VDD18	H9	Supply				
VDD18	G11	Supply				
VDD18	F12	Supply				
VDD18	B9	Supply				
VDD18	E5	Supply				
VDDIO ⁽⁴⁾	B5	Supply				
VDDIO	H5	Supply				
VDIG	A5	Supply				
X	A2	Analog OUT				
XT_IN	A12	Analog IN				
XT_OUT	B12	Analog OUT				
XTO	A1	Analog Input				

- Notes:
1. PD = internal pull-down resistor, PU = internal pull-up resistor, OH = switched to Output High at reset
 2. VBAT18 represent the internal power supply of the backup power domain.
 3. VDD_USB is the supply voltage for following the USB pins: USB_DM and USB_DP. For operation of the USB interface, supply of 3.0V to 3.6V is required.
 4. VDDIO is the supply voltage for the following GPIO pins: P1, P2, P8, P12, P14, P16, P17, P18, P19, P20, P21, P23, P24, P25, P26, P27 and P29.

3.2 Signal Description

Table 3-2. Signal Description

Pin Number	Pin Name	Type	Active Level	Pin Description/Comment
RF Section				
D1	RF	ANALOG IN	-	Input from SAW filter
C1	NRF	ANALOG IN	-	Inverted input from SAW filter
GPS XTAL Section				
A1	XTO	ANALOG IN	-	XTO input (23.104 MHz)/optional TCXO input
B3	NXTO	ANALOG IN	-	Inverted XTO input (23.104 MHz)/optional TCXO input
A2	X	ANALOG OUT	-	XTO interface (capacitor)
B2	NX	ANALOG OUT	-	Inverted XTO interface (capacitor)
RTC Section				
A12	XT_IN	ANALOG IN	-	Oscillator input (32.768 kHz)
B12	XT_OUT	ANALOG OUT	-	Oscillator output (32.768 kHz)
Automatic Gain Control, bandwidth setting				
A4	AGCO	ANALOG IO	-	Automatic gain control analog voltage, connect shunt capacitor to GND
D4	EGC	DIGITAL IN	-	Enable external gain control (high = software gain control, low = automatic gain control)
G12	AGCOUT0	DIGITAL OUT	-	Software gain control
C4	SDI	DIGITAL IN	-	Software gain control

Table 3-2. Signal Description (Continued)

Pin Number	Pin Name	Type	Active Level	Pin Description/Comment
Boot Section				
C6	BOOT_MODE	DIGITAL IN	-	Leave open, internal pull down
Reset				
A7	NRESET	DIGITAL IN	Low	Reset input; open drain with internal pull-up resistor
APMC/Power Management				
E9	NSHDN	DIGITAL OUT	Low	Shutdown output, connect to LDO_EN (C11)
C11	LDO_EN	DIGITAL IN	-	Enable LDO18
E10	NSLEEP	DIGITAL OUT	Low	Power-up output for GPS XTAL, connect to PUXTO (F4)
F4	PUXTO	DIGITAL IN	-	Power-up input for GPS XTAL
G4, H4	PURF	DIGITAL IN	-	Power-up input for GPS radio
F10	RF_ON	DIGITAL OUT	-	Power-up output for GPS radio, connect to PURF (G4, H4)
Advanced Interrupt Controller (AIC)				
A11, B10	EXTINT0-1	DIGITAL IN	High/Low/ Edge	External interrupt request
USART				
C10, D10	RXD1/RXD2	DIGITAL IN	-	USART receive data
C7, E6	TXD1/TXD2	DIGITAL OUT	-	USART transmit data
H6, G7	SCK1/SCK2	DIGITAL I/O	-	External synchronous serial clock
USB				
C9	USB_DP	DIGITAL I/O	-	USB data (D+)
D9	USB_DM	DIGITAL I/O	-	USB data (D-)
SPI Interface				
F8	SCK	DIGITAL I/O	-	SPI clock
H7	MOSI	DIGITAL I/O	-	Master out slave in
G5	MISO	DIGITAL I/O	-	Master in slave out
B6	NSS/NPCS0	DIGITAL I/O	Low	Slave select
F7, D6, D5	NPCS1/NPCS2 /NPCS3	DIGITAL OUT	Low	Slave select
PIO				
A11, B[6,10], C[6-8,10], D[5-8,10], E[6,7], F[6-8], G[5-8], H[6,7]	P0 to P31	DIGITAL I/O	-	Programmable I/O ports
Configuration				
B[6,10], D[5,6,8], F[6-8], H[6,7]	GPSMODE0-1 2	DIGITAL IN	-	GPS mode pins
G8	NEEPROM	DIGITAL IN	Low	Enable EEPROM support
GPS				
D7	STATUSLED	DIGITAL OUT	-	Status LED
G7	TIMEPULSE	DIGITAL OUT	-	GPS synchronized time pulse

Table 3-2. Signal Description (Continued)

Pin Number	Pin Name	Type	Active Level	Pin Description/Comment
Active Antenna Supervision				
C8	NANTSHORT	DIGITAL IN	Low	Active antenna short detection Input
G5, G6	NAADET0/ NAADET1	DIGITAL IN	Low	Active antenna detection Input
F11	ANTON	DIGITAL OUT	-	Active antenna power-on Output
JTAG Interface				
E8	DBG_EN	DIGITAL IN	-	Debug enable
F9	TDO	DIGITAL OUT	-	Test data out
G9	TCK	DIGITAL IN	-	Test clock
G10	TMS	DIGITAL IN	-	Test mode select
H10	TDI	DIGITAL IN	-	Test data in
H11	NTRST	DIGITAL IN	Low	Test reset input
Debug/Test				
C3	MO	ANALOG OUT	-	IF output buffer
D3	TEST	ANALOG IN	-	Enable IF output buffer
B7	SIGLO	DIGITAL OUT	-	Digital IF (data output "Low")
B8	SIGHI	DIGITAL OUT	-	Digital IF (data output "High")
A8	CLK23	DIGITAL OUT	-	Digital IF (sample clock)
Power Analog Part				
C2	VCC1	SUPPLY	-	Analog supply 3V
E4	VCC2	SUPPLY	-	Analog supply 3V
G2, G3, H2, H3	VBP	SUPPLY	-	Analog supply 3V
A3, B1, B4, D2, E[1-3], F[1-3], G1, H1	GNDA	SUPPLY	-	Analog Ground
Power Digital Part				
A5	VDIG	SUPPLY	-	Digital supply (radio) 1.8V
B9, E5, F12, G11,H9	VDD18	SUPPLY	-	Core voltage 1.8V
A10	VDD_USB	SUPPLY	-	USB transceiver supply voltage (3.0V to 3.6V (USB enabled) or 0 to 2.0V (USB disabled))
B5, H5	VDDIO	SUPPLY	-	Variable I/O voltage 1.65V to 3.6V
C5	GDIG	SUPPLY	-	Digital ground (radio)
A6, A9, B11, F5, H8, H12	GND	SUPPLY	-	Digital ground
LDO18				
E11	LDO_IN	SUPPLY	-	2.3V to 3.6V
E12	LDO_OUT	SUPPLY	-	1.8V LDO18 output, max. 80 mA
LDOBAT				
D11	LDOBAT_IN	SUPPLY	-	2.3V to 3.6V
D12	VBAT	SUPPLY	-	1.5V to 3.6V
C12	VBAT18	SUPPLY	-	1.8V LDOBAT Output

3.3 External Connections for a Working GPS System

Figure 3-2. Example of an External Connection (ATR0630P1)

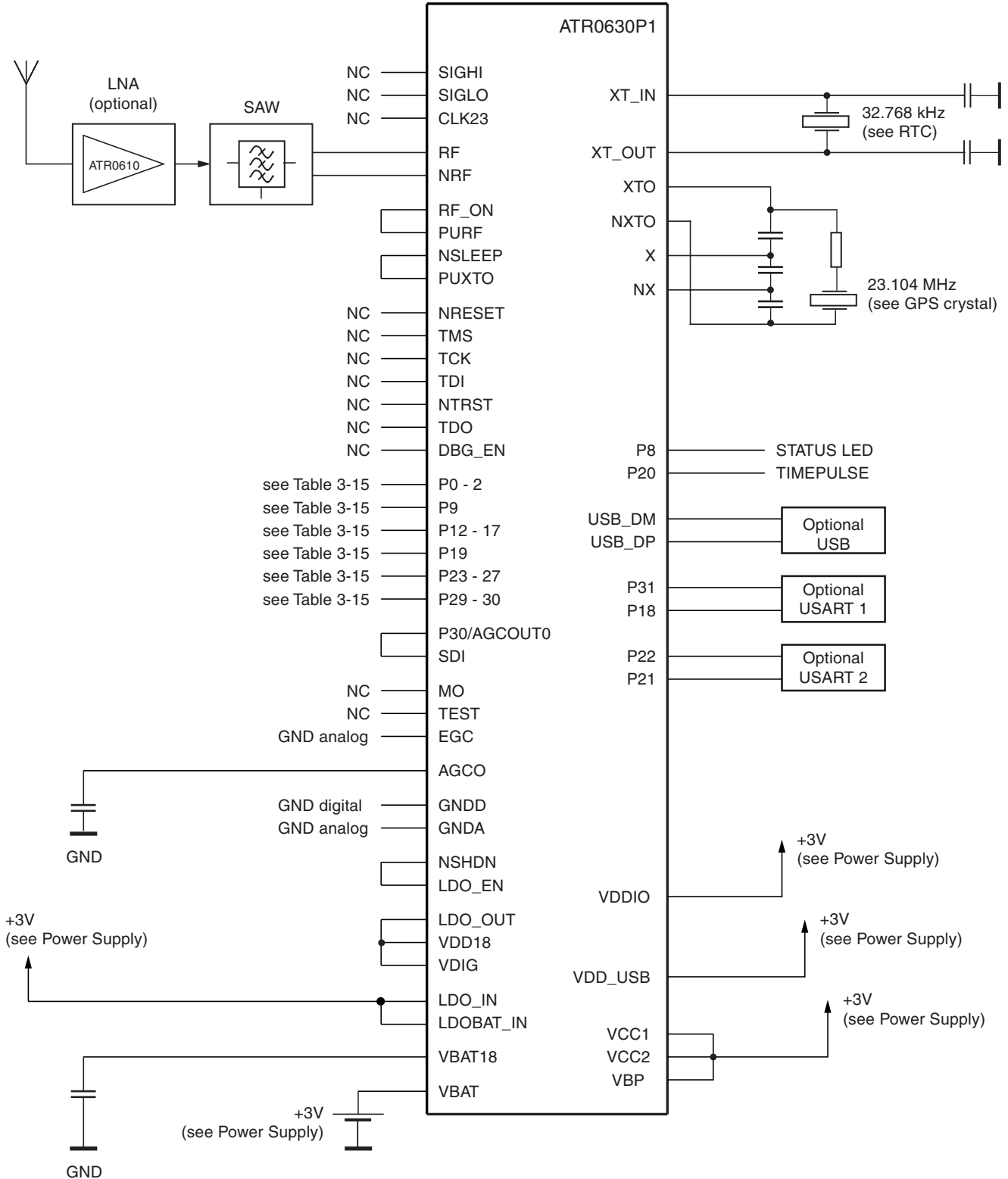

4. Ordering Information

Extended Type Number	Package	MPQ	Remarks
ATR0630P1-7KQY	BGA96	3000	7 mm × 10 mm, 0.8 mm pitch, Pb-free, RoHS-compliant
ATR0630-EK1	-	1	Evaluation kit/Road test kit
ATR0630-DK1	-	1	Design kit including design guide and PCB Gerber files

5. Package Information

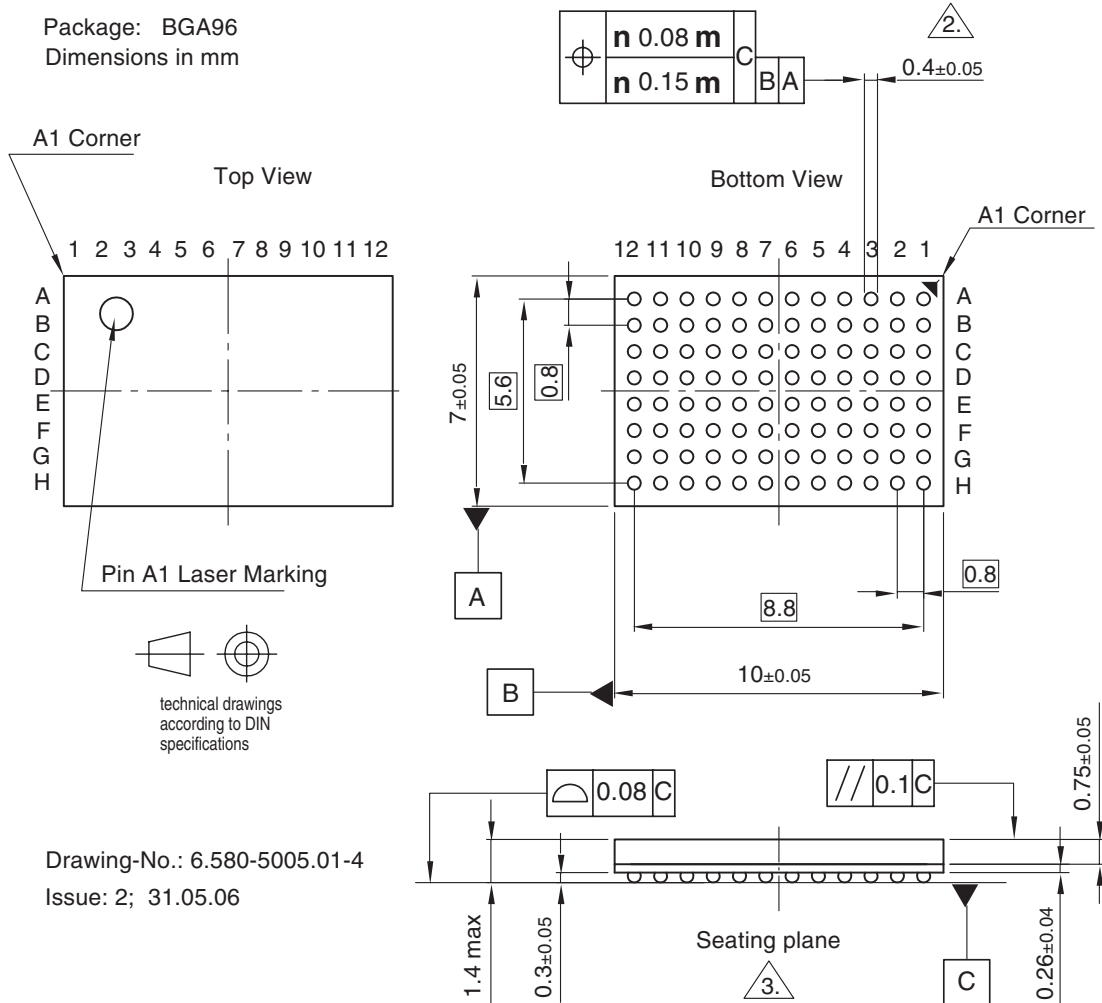

Note:

- All dimensions and tolerance conform to ASME Y 14.5M-1994
- 2. Dimension is measured at the maximum solder ball diameter, parallel to primary datum C
- 3. Primary datum C and seating plane are defined by the spherical crowns of the solder balls
- The surface finish of the package shall be EDM CHARMILLE #24 - #27
- Unless otherwise specified tolerance: Decimal ± 0.05 , Angular $\pm 2^\circ$
- Raw ball diameter: 0.4 mm ref.



Headquarters

Atmel Corporation
2325 Orchard Parkway
San Jose, CA 95131
USA
Tel: 1(408) 441-0311
Fax: 1(408) 487-2600

International

Atmel Asia
Room 1219
Chinachem Golden Plaza
77 Mody Road Tsimshatsui
East Kowloon
Hong Kong
Tel: (852) 2721-9778
Fax: (852) 2722-1369

Atmel Europe
Le Krebs
8, Rue Jean-Pierre Timbaud
BP 309
78054
Saint-Quentin-en-Yvelines Cedex
France
Tel: (33) 1-30-60-70-00
Fax: (33) 1-30-60-71-11

Atmel Japan
9F, Tonetsu Shinkawa Bldg.
1-24-8 Shinkawa
Chuo-ku, Tokyo 104-0033
Japan
Tel: (81) 3-3523-3551
Fax: (81) 3-3523-7581

Product Contact

Web Site
www.atmel.com

Technical Support
gps@atmel.com

Sales Contact
www.atmel.com/contacts

Literature Requests
www.atmel.com/literature

Disclaimer: The information in this document is provided in connection with Atmel products. No license, express or implied, by estoppel or otherwise, to any intellectual property right is granted by this document or in connection with the sale of Atmel products. **EXCEPT AS SET FORTH IN ATMEL'S TERMS AND CONDITIONS OF SALE LOCATED ON ATMEL'S WEB SITE, ATMEL ASSUMES NO LIABILITY WHATSOEVER AND DISCLAIMS ANY EXPRESS, IMPLIED OR STATUTORY WARRANTY RELATING TO ITS PRODUCTS INCLUDING, BUT NOT LIMITED TO, THE IMPLIED WARRANTY OF MERCHANTABILITY, FITNESS FOR A PARTICULAR PURPOSE, OR NON-INFRINGEMENT. IN NO EVENT SHALL ATMEL BE LIABLE FOR ANY DIRECT, INDIRECT, CONSEQUENTIAL, PUNITIVE, SPECIAL OR INCIDENTAL DAMAGES (INCLUDING, WITHOUT LIMITATION, DAMAGES FOR LOSS OF PROFITS, BUSINESS INTERRUPTION, OR LOSS OF INFORMATION) ARISING OUT OF THE USE OR INABILITY TO USE THIS DOCUMENT, EVEN IF ATMEL HAS BEEN ADVISED OF THE POSSIBILITY OF SUCH DAMAGES.** Atmel makes no representations or warranties with respect to the accuracy or completeness of the contents of this document and reserves the right to make changes to specifications and product descriptions at any time without notice. Atmel does not make any commitment to update the information contained herein. Unless specifically provided otherwise, Atmel products are not suitable for, and shall not be used in, automotive applications. Atmel's products are not intended, authorized, or warranted for use as components in applications intended to support or sustain life.



© 2007, Atmel Corporation. All rights reserved. Atmel®, logo and combinations thereof, and others are registered trademarks or trademarks of Atmel Corporation or its subsidiaries. ARM®, ARM Powered® logo, Thumb® and others are the registered trademarks or trademarks of ARM Ltd. Other terms and product names may be trademarks of others.