

Features

- System Solution for Immobilizer and Remote Keyless Entry Functionality
- Optional Integrated Open Source Immobilizer Software Stack Supports Automotive Immobilizer Applications (CMMI Certified)
- Integrated Ultra-low Power Flash Atmel AVR (8-bit) Microcontroller
- 2112-byte EEPROM
- 32-bit Unique Device Identification Number
- Available in Small 5x5 QFN32 Pin Package

Contactless Transponder

- LF Contactless Transponder Operation in Passive and Active Modes
- Integrated Coders for Enhanced LF Communication Range
- Ultra Low-power AES-128 Cryptographic Engine for Use of Immobilizer and RKE Applications
- Access Protected Area for two 128-bit Secret Keys for Device Authentication
- Optional One 128-bit Transport Key for Initial Configuration
- LF Receiver Data Integrity Check (CRC-4/CRC-8)

RF Transmitter

- Fully Integrated Fractional-N PLL, VCO and Loop Filter Covering 315MHz and 433MHz (Software Programmable)
- Output Power Programmable from -0.5 to +12.5dBm
- Supports ASK and FSK Modulation with Data Rate up to 40Kbit/s
- Extended Battery Lifetime Due to Fast Start-up Time, Low Operating Voltage and Low Supply Current

Ultra-low-power AVR Microcontroller

- 8Kbyte Flash Program Memory (Including 2KB of Immobilizer Software Stack)
- 2112-byte EEPROM – Includes Protected User Data and Device Configuration Data (64Bytes)
- Error Correction Code (ECC) Engine Protects Flash and EEPROM
- 512Bytes of SRAM
- Four GP Timers
 - T0: Flexible WD and Interval Timers
 - T1: 15-bit Interval Timer
 - T2: Asynchronous 8-bit Timer/Counter with Output Compare
 - T3: Asynchronous 8-bit Timer/Counter with Output Compare and Input Capture
- Power Management Unit
- System Clock Management and Monitoring Functions
- POR and Brown-out Detection
- Programmable Voltage Monitor
- RTC and Two Internal System Clock RC Oscillators with $f_1 = 125\text{kHz}$, $f_2 = 4\text{MHz}$
- SPI, TM/SSI, IR digital interfaces; dW 1-wire Debug IF with AVR Development Tools
- Very Low Power Consumption:
 - Active: 50 μA (Sys_Clk at 125kHz)
 - Idle: < 70 μA (Sys_Clk at 1MHz)
 - Power-down: 0.8 μA
 - EE(wr): 50 μA
- Wide Battery Voltage Range from 1.9 to 3.6V (in Contact Mode)
- -40 to +85°C Operation Temperature
- Automotive Grade C Compiler



Embedded AVR Microcontroller Including RF Transmitter and Immobilizer LF Functionality for Remote Keyless Entry

Atmel
ATA5795C

Summary

Preliminary

NOTE: This is a summary document. The complete document is available under NDA. For more information, please contact your local Atmel sales office.

9182CS-RKE-11/11



1. Description

Atmel® ATA5795C is a smart Remote Keyless Entry (RKE) device that includes an embedded ultra-low-power AVR® 8-bit microcontroller, a fractional-N RF transmitter and an LF immobilizer interface in a single QFN32 package.

Furthermore, the device has an integrated AES-128 cryptography hardware engine, which is accessible by both the immobilizer and the RKE unit. The immobilizer interface can run in contactless mode, allowing energy supply and data transmission via the LF link.

The Atmel ATA5795C is designed for automotive applications that necessitate both immobilization and Remote Keyless Entry functions in one single key. It conforms to requirements of extremely low power consumption and provides all the necessary circuitry for the entire application.

1.1 System Block Diagram

Figure 1-1. System Block Diagram

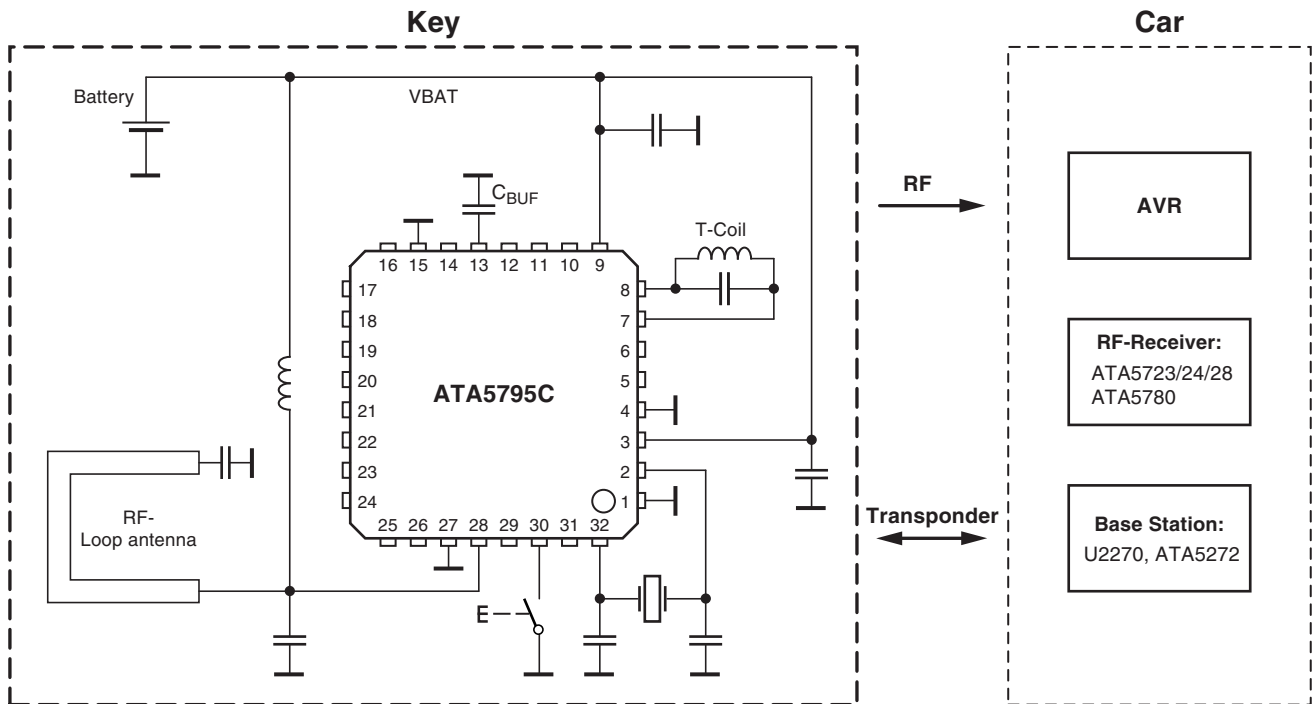

1.2 Atmel ATA5795C Block Diagram

Figure 1-2. Atmel® ATA5795C Block Diagram

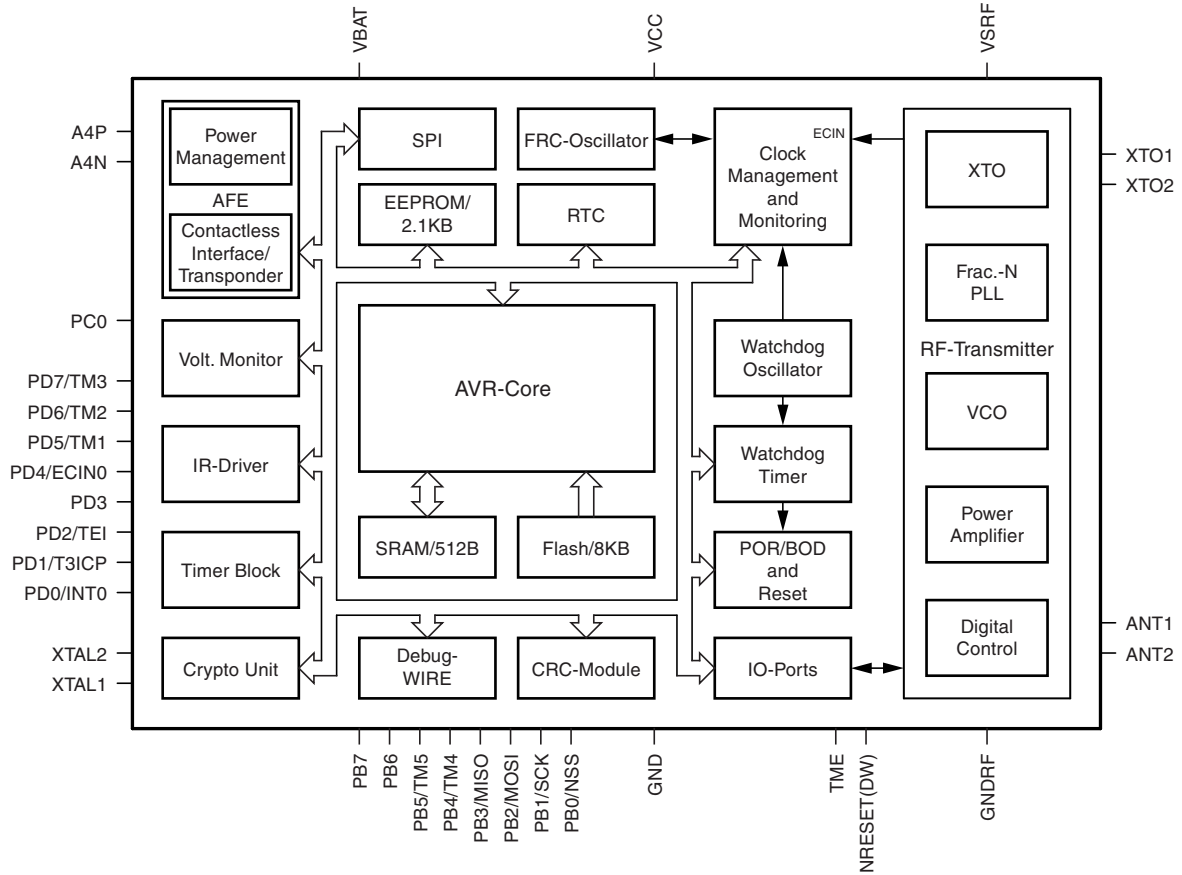

1.3 Pin Configurations

Figure 1-3. Pin Out for QFN 32 Package

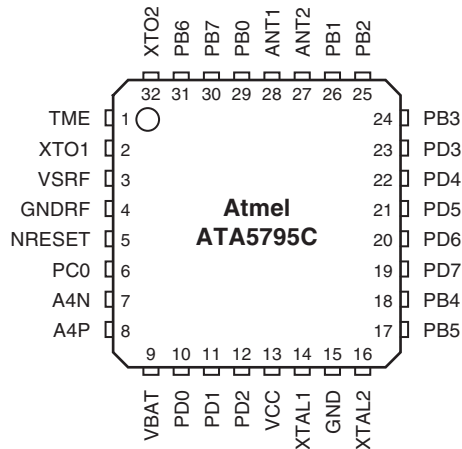

Table 1-1. Pin Description

Pin Number	Pin Name	Alternate Function 1	Alternate Function 2	Function	Comment
1	TME	-	-	Test mode enable	
2	XTO1	-	-	Connection for RF crystal	RF - pin
3	VSRF	-	-	Power supply voltage RF	RF - pin
4	GNDRF	-	-	Power supply ground RF	RF - pin
5	NRESET	dW	-	Reset input / debugWire interface	
6	PC0	-	-	I/O port	Port C0
7	A4N	-	-	Input pin for transponder AFE	
8	A4P	-	-	Input pin for transponder AFE	
9	VBAT	-	-	Power supply voltage for battery	
10	PD0	INT0	PCINT8	I/O port / external interrupt input 0	Port D0
11	PD1	T3ICP	PCINT9	I/O port / timer 3 external capture input	Port D1
12	PD2	TEI	PCINT10	I/O port / external timer input clock	Port D2
13	VCC	-	-	Power supply voltage for the microcontroller. A capacitor with capacitance C_{BUF} must be connected at this pin to buffer the voltage during field supply and block the microcontroller VCC.	
14	XTAL1	-	-	32kHz crystal oscillator input pin	
15	GND	-	-	Power supply ground	
16	XTAL2	-	-	32kHz crystal oscillator output pin	
17	PB5	TM5	PCINT5	I/O port / timer modulator pin 5	Port B5
18	PB4	TM4	PCINT4	I/O port / timer modulator pin 4	Port B4
19	PD7	TM3	PCINT15	I/O port / timer modulator pin 3	Port D7
20	PD6	TM2	PCINT14	I/O port / timer modulator pin 2	Port D6
21	PD5	TM1	PCINT13	I/O port / timer modulator pin 1	Port D5
22	PD4	ECIN0	PCINT12	I/O port / external clock input 0	Port D4
23	PD3	-	PCINT11	I/O port	Port D3
24	PB3	MISO	PCINT3	I/O port / SPI	Port B3
25	PB2	MOSI	PCINT2	I/O port / SPI	Port B2
26	PB1	SCK	PCINT1	I/O port / SPI	Port B1
27	ANT2	-	-	RF antenna 2	RF - pin
28	ANT1	-	-	RF antenna 1	RF - pin
29	PB0	NSS	PCINT0	I/O port / SPI	Port B0
30	PB7	-	PCINT7	I/O port	Port B7
31	PB6	-	PCINT6	I/O port	Port B6
32	XTO2	-	-	Connection for RF crystal	RF - pin

2. Ordering Information

Extended Type Number	Package	Remarks
ATA5795C-PNQW	QFN32 - 5x5	Pb-free

3. Package Information

Figure 3-1. QFN 32 - 5x5 Package

Package: QFN_ 5 x 5_32L

Exposed pad 3.6 x 3.6

Dimensions in mm

Not indicated tolerances ± 0.05

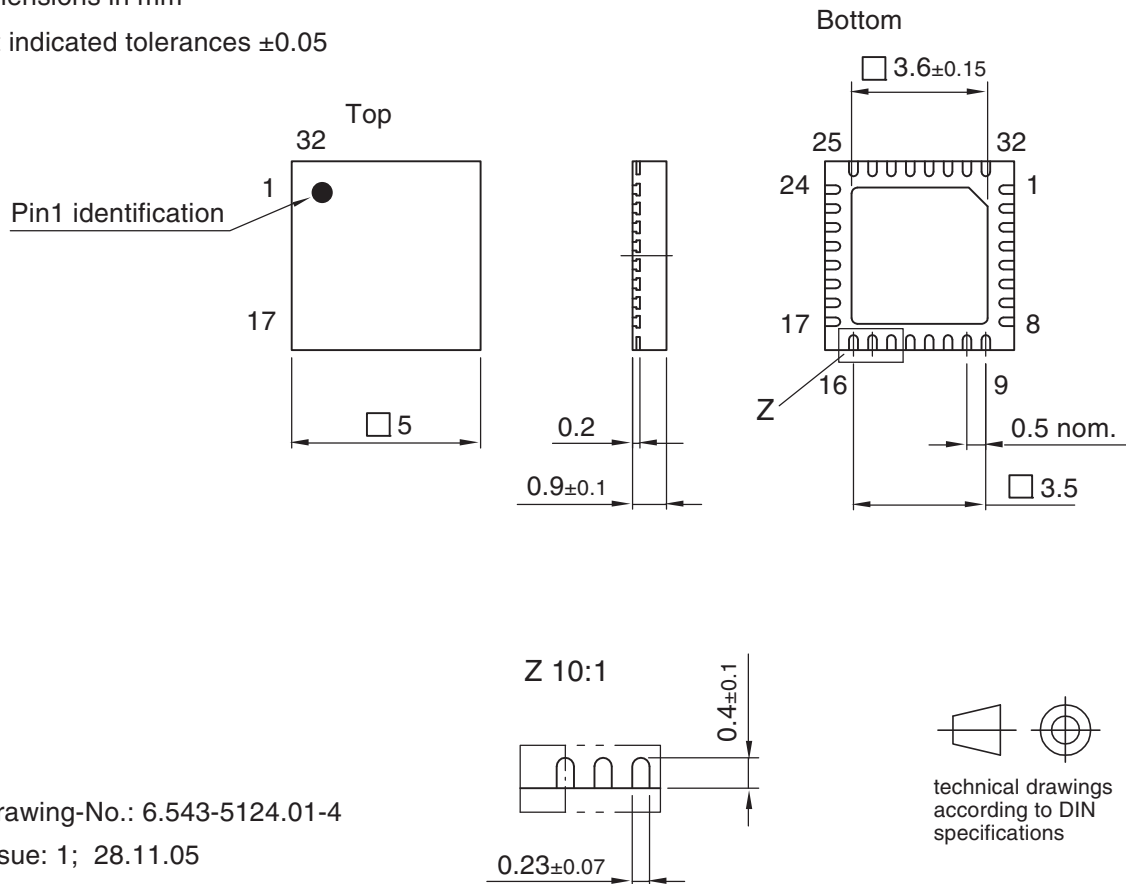

Drawing-No.: 6.543-5124.01-4

Issue: 1; 28.11.05

4. Revision History

Please note that the following page numbers referred to in this section refer to the specific revision mentioned, not to this document.

Revision No.	History
9182CS-RKE-11/11	• ATA5795 to ATA5795C renamed
9182BS-RKE-07/11	• Document completely redesigned



Atmel Corporation

2325 Orchard Parkway
San Jose, CA 95131
USA

Tel: (+1)(408) 441-0311

Fax: (+1)(408) 487-2600

Atmel Asia Limited

Unit 01-5 & 16, 19/F
BEA Tower, Millennium City 5
418 Kwun Tong Road
Kwun Tong, Kowloon
HONG KONG

Tel: (+852) 2245-6100

Fax: (+852) 2722-1369

Atmel Munich GmbH

Business Campus
Parking 4
D-85748 Garching b. Munich
GERMANY

Tel: (+49) 89-31970-0

Fax: (+49) 89-3194621

Atmel Japan

9F, Tonetsu Shinkawa Bldg.
1-24-8 Shinkawa
Chuo-ku, Tokyo 104-0033
JAPAN

Tel: (+81) (3) 3523-3551

Fax: (+81) (3) 3523-7581

© 2011 Atmel Corporation. All rights reserved. / Rev.: 9182CS-RKE-11/11

Atmel®, Atmel logo and combinations thereof, AVR® and others are registered trademarks or trademarks of Atmel Corporation or its subsidiaries. Other terms and product names may be trademarks of others.

Disclaimer: The information in this document is provided in connection with Atmel products. No license, express or implied, by estoppel or otherwise, to any intellectual property right is granted by this document or in connection with the sale of Atmel products. EXCEPT AS SET FORTH IN THE ATMEL TERMS AND CONDITIONS OF SALES LOCATED ON THE ATMEL WEBSITE, ATMEL ASSUMES NO LIABILITY WHATSOEVER AND DISCLAIMS ANY EXPRESS, IMPLIED OR STATUTORY WARRANTY RELATING TO ITS PRODUCTS INCLUDING, BUT NOT LIMITED TO, THE IMPLIED WARRANTY OF MERCHANTABILITY, FITNESS FOR A PARTICULAR PURPOSE, OR NON-INFRINGEMENT. IN NO EVENT SHALL ATMEL BE LIABLE FOR ANY DIRECT, INDIRECT, CONSEQUENTIAL, PUNITIVE, SPECIAL OR INCIDENTAL DAMAGES (INCLUDING, WITHOUT LIMITATION, DAMAGES FOR LOSS AND PROFITS, BUSINESS INTERRUPTION, OR LOSS OF INFORMATION) ARISING OUT OF THE USE OR INABILITY TO USE THIS DOCUMENT, EVEN IF ATMEL HAS BEEN ADVISED OF THE POSSIBILITY OF SUCH DAMAGES. Atmel makes no representations or warranties with respect to the accuracy or completeness of the contents of this document and reserves the right to make changes to specifications and products descriptions at any time without notice. Atmel does not make any commitment to update the information contained herein. Unless specifically provided otherwise, Atmel products are not suitable for, and shall not be used in, automotive applications. Atmel products are not intended, authorized, or warranted for use as components in applications intended to support or sustain life.