

Features

- Lamp Outage Indication for Car and Trailer
- Temperature and Supply Voltage Compensated Flashing Frequency
- Relay Driver Output with High Current Carrying Capacity and Low Saturation Voltage
- Minimum Lamp Load for Flasher Operation > 10W

1. Description

The bipolar integrated Atmel® circuit ATA2069 is designed for the use in relay-operated automotive flasher modules and makes it possible to detect the outage of flasher bulbs on the vehicle itself and also on a trailer.

Vehicles with a trailer hook are equipped with additional pilot lamps in the dashboard.

Atmel ATA2069 is off (i.e., the relay is deactivated) as long as the flasher switch (at contact +49a) is open. As soon as this switch is closed, the IC starts reliably with the bright phase.

There are two thresholds integrated: one threshold is defined to be 21 + 10W and is designed for the lamp outage detection of 1 of 2 lamps. If the current is below this threshold, the IC switches to frequency doubling, just like the standard flashers (e.g. Atmel U2043B).

The other threshold is defined to be 42 + 10W and is designed for the outage detection of 1 of 3 lamps; if this happens, the additional trailer pilot lamp is switched off, but there is no frequency doubling. 50 ms after the start of the bright phase, the comparator measures the voltage drop at the shunt and latches this value for the rest of the bright phase. The output of this pilot lamp (pin 8) is short-circuit protected against GND. In case of a short circuit the external transistor is switched off after 52ms for the rest of the current flasher cycle, but it is enabled again for the next cycle.



Flasher with Trailer Control

Atmel ATA2069

2. Pin Configuration

Figure 2-1. Pinning

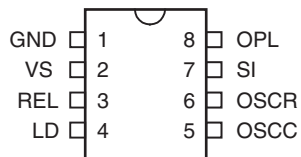

Table 2-1. Pin Description

Pin	Symbol	Function
1	GND	IC ground
2	VS	Supply Voltage
3	REL	Relay driver
4	LD	Lamp failure detection
5	OSCC	Cap. oscillator
6	OSCR	Res. oscillator
7	SI	Start input (49a)
8	OPL	Output pilot lamp

3. Absolute Maximum Ratings

Stresses beyond those listed under “Absolute Maximum Ratings” may cause permanent damage to the device. This is a stress rating only and functional operation of the device at these or any other conditions beyond those indicated in the operational sections of this specification is not implied. Exposure to absolute maximum rating conditions for extended periods may affect device reliability.

Parameters	Pin	Symbol	Value	Unit
Supply voltage	2	V_S	16.5	V
Junction temperature		T_J	150	°C
Ambient temperature range		T_{amb}	-40 to +95	°C
Storage temperature range		T_{stg}	-55 to +150	°C
Thermal resistance junction ambient SO8		R_{thjc}	160	K/W

4. Electrical Characteristics

Parameters	Test Conditions	Pin	Symbol	Min.	Typ.	Max.	Unit
Supply voltage range		2	$V_S (+49a)$		9 to 15		V
Relay output current		3	I_{Rel}			300	mA
Relay saturation voltage	$I = 130mA$	3	V_{Rel}			1	V
	$I = 250mA$					1.5	V
Relay leakage current		3	I_{Relr}			100	µA
Values for $T = 25^\circ C$							
Start delay			t_{on}			10	ms
Delay time for output OPL		OPL	t_{Del}	45		55	ms
Switch off delay time output OPL in case of short circuit		OPL	t_{Del}	1.5		2.4	ms
Voltage threshold for short circuit detection at output OPL		OPL	V_{th}	36		44	% of U_S
Output current at OPL		OPL	I_O	10		25	mA
Saturation voltage at OPL		OPL	V_{SATO}			300	mV
Control signal threshold K1 for outage detection without trailer operation	$V_S = 9V$		V_{k1}	47.5	50	52.2	mV
	$V_S = 13V$	54.2		57	59.9	mV	
	$V_S = 15V$	58		61	64.1	mV	
Control signal threshold K4 for outage detection with trailer operation	$V_S = 9V$		V_{k4}	96	98	100	mV
	$V_S = 13V$	109		111	113	mV	
	$V_S = 15V$	115		118	120	mV	
Frequency tolerance			Delta f1	-5		+5	%
Bright period	Basic frequency		Delta f1	47		53	%
Bright period	Frequency doubling		Delta f2	37		45	%
Frequency increase	Lamp outage		f2	$2.15 \times f$		$2.3 \times f$	Hz
Leakage increase	49a to GND		RI			5	kΩ
Lamp load			PL	10			W

5. Ordering Information

Extended Type Number	Package	Remarks
ATA2069-TAQY	SO8	Taped and reeled, Pb-free

6. Package Information

Package: SO 8

Dimensions in mm

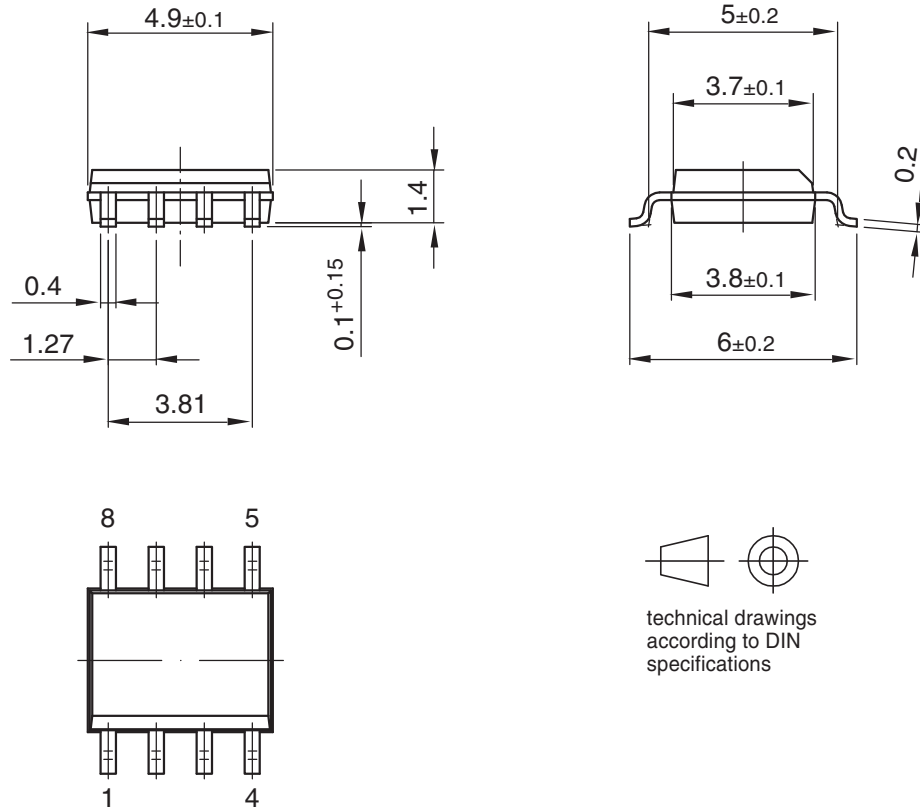

Drawing-No.: 6.541-5031.01-4

Issue: 1; 15.08.06

7. Revision History

Please note that the following page numbers referred to in this section refer to the specific revision mentioned, not to this document.

Revision No.	History
4917D-AUTO-03/11	<ul style="list-style-type: none">• Section 3 “Absolute Maximum Ratings” on page 4 changed• Section 5 “Ordering Information” on page 5 changed• Section 6 “Package Information” on page 5 changed
4917C-AUTO-10/07	<ul style="list-style-type: none">• Section 5 “Ordering Information” on page 5 changed
4917B-AUTO-03/06	<ul style="list-style-type: none">• Section 5 “Ordering Information” on page 5 changed



Atmel Corporation

2325 Orchard Parkway
San Jose, CA 95131
USA

Tel: (+1)(408) 441-0311

Fax: (+1)(408) 487-2600

Atmel Asia Limited

Unit 01-5 & 16, 19/F
BEA Tower, Millennium City 5
418 Kwun Tong Road
Kwun Tong, Kowloon
HONG KONG

Tel: (+852) 2245-6100

Fax: (+852) 2722-1369

Atmel Munich GmbH

Business Campus
Parking 4
D-85748 Garching b. Munich
GERMANY

Tel: (+49) 89-31970-0

Fax: (+49) 89-3194621

Atmel Japan

9F, Tonetsu Shinkawa Bldg.
1-24-8 Shinkawa
Chuo-ku, Tokyo 104-0033
JAPAN

Tel: (+81) (3) 3523-3551

Fax: (+81) (3) 3523-7581

© 2011 Atmel Corporation. All rights reserved. / Rev.: 4917D-AUTO-03/11

Atmel®, Atmel logo and combinations thereof, and others are registered trademarks or trademarks of Atmel Corporation or its subsidiaries. Other terms and product names may be trademarks of others.

Disclaimer: The information in this document is provided in connection with Atmel products. No license, express or implied, by estoppel or otherwise, to any intellectual property right is granted by this document or in connection with the sale of Atmel products. EXCEPT AS SET FORTH IN THE ATMEL TERMS AND CONDITIONS OF SALES LOCATED ON THE ATMEL WEBSITE, ATMEL ASSUMES NO LIABILITY WHATSOEVER AND DISCLAIMS ANY EXPRESS, IMPLIED OR STATUTORY WARRANTY RELATING TO ITS PRODUCTS INCLUDING, BUT NOT LIMITED TO, THE IMPLIED WARRANTY OF MERCHANTABILITY, FITNESS FOR A PARTICULAR PURPOSE, OR NON-INFRINGEMENT. IN NO EVENT SHALL ATMEL BE LIABLE FOR ANY DIRECT, INDIRECT, CONSEQUENTIAL, PUNITIVE, SPECIAL OR INCIDENTAL DAMAGES (INCLUDING, WITHOUT LIMITATION, DAMAGES FOR LOSS AND PROFITS, BUSINESS INTERRUPTION, OR LOSS OF INFORMATION) ARISING OUT OF THE USE OR INABILITY TO USE THIS DOCUMENT, EVEN IF ATMEL HAS BEEN ADVISED OF THE POSSIBILITY OF SUCH DAMAGES. Atmel makes no representations or warranties with respect to the accuracy or completeness of the contents of this document and reserves the right to make changes to specifications and products descriptions at any time without notice. Atmel does not make any commitment to update the information contained herein. Unless specifically provided otherwise, Atmel products are not suitable for, and shall not be used in, automotive applications. Atmel products are not intended, authorized, or warranted for use as components in applications intended to support or sustain life.