

Features

- No External Components Except PIN Diode
- Supply-voltage Range: 2.7V to 5.5V
- High Sensitivity Due to Automatic Sensitivity Adaption (AGC) and Automatic Strong Signal Adaption (ATC)
- Automatic Supply Voltage Adaptation
- High Immunity against Disturbances from Daylight and Lamps
- Small Size and Innovative Pad Layout
- Available for Carrier Frequencies between 33 kHz to 40 kHz and 56 kHz; Adjusted by Zener Diode Fusing $\pm 2.5\%$
- TTL and CMOS Compatible

Applications

- Home Entertainment Applications
- Home Appliances
- Remote Control Equipment

1. Description

The IC ATA2526 is a complete IR receiver for data communication that has been developed and optimized for use in carrier-frequency-modulated transmission applications. The IC combines small size with high sensitivity suppression of noise as caused by daylight and lamps. An innovative and patented pad layout offers unique flexibility for IR receiver module assembly. The ATA2526 is available with standard frequencies (33, 36, 37, 38, 40, 56 kHz) and 3 different noise suppression regulation types (standard, lamp, short burst), thus covering the requirements of different high-volume remote control solutions (please refer to selection guide available for ATA2525/ATA2526). The ATA2526 operates in a supply voltage range of 2.7V to 5.5V.

The function of the ATA2526 can be described using the block diagram of [Figure 1-1 on page 2](#). The input stage has two main functions. First it provides a suitable bias voltage for the PIN diode. Secondly the pulsed photo-current signals are transformed into a voltage by a special circuit which is optimized for low noise applications. After amplification by a Controlled Gain Amplifier (CGA) the signals have to pass a tuned integrated narrow bandpass filter with a center frequency f_0 which is equivalent to the chosen carrier frequency of the input signal. The demodulator is used first to convert the input burst signal to a digital envelope output pulse and to evaluate the signal information quality, i.e., unwanted pulses will be suppressed at the output pin. This is done by means of an integrated dynamic feedback circuit which varies the gain as a function of the present environmental conditions (ambient light, modulated lamps etc.). Other features can be used to adapt the device to the individual application to ensure best transmission quality.



Low-voltage IR Receiver ASSP

ATA2526

Figure 1-1. Block Diagram

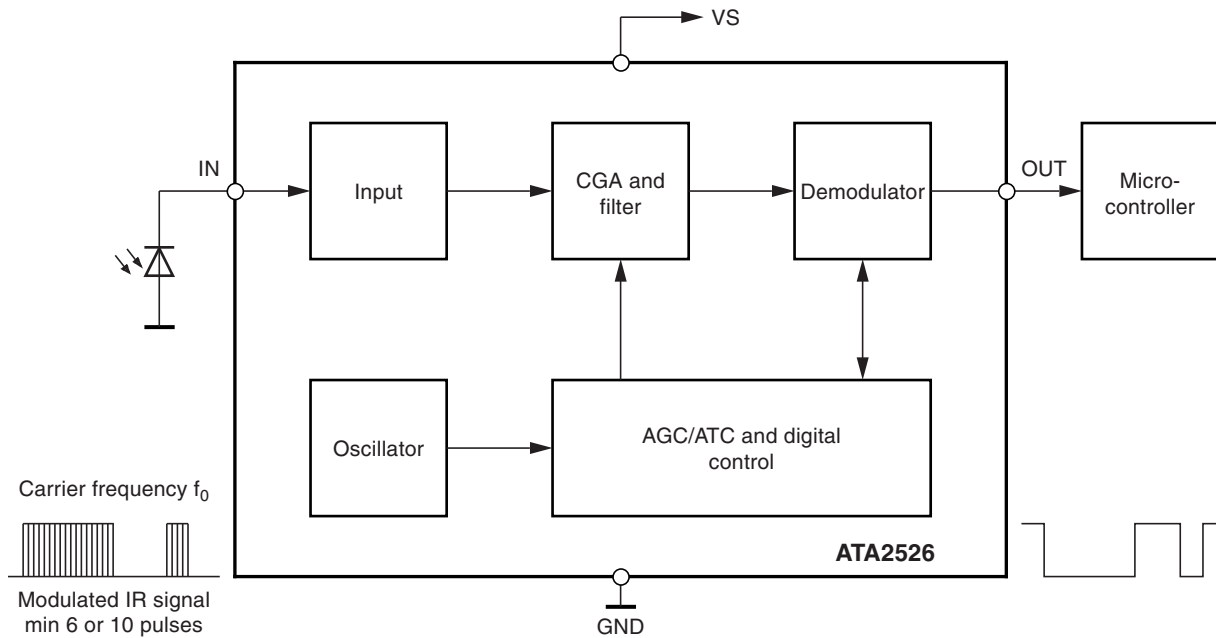

2. Absolute Maximum Ratings

Stresses beyond those listed under “Absolute Maximum Ratings” may cause permanent damage to the device. This is a stress rating only and functional operation of the device at these or any other conditions beyond those indicated in the operational sections of this specification is not implied. Exposure to absolute maximum rating conditions for extended periods may affect device reliability.

Parameter	Symbol	Value	Unit
Supply voltage	V_S	-0.3 to +6	V
Supply current	I_S	3	mA
Input voltage	V_{IN}	-0.3 to V_S	V
Input DC current at $V_S = 5V$	I_{IN}	0.75	mA
Output voltage	V_O	-0.3 to V_S	V
Output current	I_O	10	mA
Operating temperature	T_{amb}	-25 to +85	°C
Storage temperature	T_{stg}	-40 to +125	°C
Power dissipation at $T_{amb} = 25^\circ C$	P_{tot}	30	mW

3. Electrical Characteristics, 3-V Operation

$T_{amb} = -25^{\circ}\text{C}$ to $+85^{\circ}\text{C}$, $V_S = 2.7\text{V}$ to 3.3V unless otherwise specified.

No.	Parameters	Test Conditions	Symbol	Min.	Typ.	Max.	Unit	Type*
1	Supply							
1.1	Supply-voltage range		V_S	2.7	3.0	3.3	V	C
1.2	Supply current	$I_{IN}=0$	I_S	0.7	0.9	1.3	mA	B
2	Output							
2.1	Internal pull-up resistor	$T_{amb} = 25^{\circ}\text{C}$ see Figure 5-10 on page 9	R_{PU}		40		k Ω	A
2.2	Output voltage low	$R_2 = 1.4\text{ k}\Omega$ see Figure 5-10 on page 9	V_{OL}			250	mV	B
2.3	Output voltage high		V_{OH}	$V_S - 0.25$		V_S	V	B
2.4	Output current clamping	$R_2 = 0$ see Figure 5-10 on page 9	I_{OCL}		8		mA	B
3	Input							
3.1	Input DC current	$V_{IN} = 0$ see Figure 5-10 on page 9	I_{IN_DCMAX}	-150			μA	C
3.2	Input DC current see Figure 5-3 on page 6	$V_{IN} = 0$; $V_S = 3\text{V}$ $T_{amb} = 25^{\circ}\text{C}$	I_{IN_DCMAX}		-350		μA	B
3.3	Minimum detection threshold current see Figure 5-1 on page 6	Test signal: see Figure 5-9 on page 9 $V_S = 3\text{V}$	I_{Eemin}		-800		pA	B
3.4	Minimum detection threshold current with AC current disturbance $I_{IN_AC100} = 3\text{ }\mu\text{A}$ at 100 Hz	$T_{amb} = 25^{\circ}\text{C}$, $I_{IN_DC} = 1\text{ }\mu\text{A}$ square pp burst $N = 16$ $f = f_0$; $t_{PER} = 10\text{ ms}$ see Figure 5-8 on page 8 BER = 50% ⁽¹⁾	I_{Eemin}		-1600		pA	C
3.5	Maximum detection threshold current with $V_{IN} > 0\text{V}$	Test signal: see Figure 5-9 on page 9 $V_S = 3\text{V}$, $T_{amb} = 25^{\circ}\text{C}$ $I_{IN_DC} = 1\text{ }\mu\text{A}$ square pp burst $N = 16$ $f = f_0$; $t_{PER} = 10\text{ ms}$ see Figure 5-8 on page 8 BER = 5% ⁽¹⁾	I_{Eemax}	-200			μA	D
4	Controlled Amplifier and Filter							
4.1	Maximum value of variable gain (CGA)	$V_S = 3\text{V}$, $T_{amb} = 25^{\circ}\text{C}$	G_{VARMAX}		50		dB	D
4.2	Minimum value of variable gain (CGA)	$V_S = 3\text{V}$, $T_{amb} = 25^{\circ}\text{C}$	G_{VARMIN}		-6		dB	D
4.3	Total internal amplification ⁽²⁾	$V_S = 3\text{V}$, $T_{amb} = 25^{\circ}\text{C}$	G_{MAX}		72		dB	D
4.4	Center frequency fusing accuracy of bandpass	$V_S = 3\text{V}$, $T_{amb} = 25^{\circ}\text{C}$	f_{03V_FUSE}	-2.5	f_0	+2.5	%	A

*) Type means: A = 100% tested, B = 100% correlation tested, C = Characterized on samples, D = Design parameter

- Notes: 1. BER = bit error rate; e.g., BER = 5% means that with $P = 20$ at the input pin 19...21 pulses can appear at the pin OUT
2. After transformation of input current into voltage

3. Electrical Characteristics, 3-V Operation (Continued)

$T_{amb} = -25^{\circ}\text{C}$ to $+85^{\circ}\text{C}$, $V_S = 2.7\text{V}$ to 3.3V unless otherwise specified.

No.	Parameters	Test Conditions	Symbol	Min.	Typ.	Max.	Unit	Type*
4.5	Overall accuracy center frequency of bandpass		f_{03V}	-5.5	f_0	+3.5	%	C
4.6	Overall accuracy center frequency of bandpass	$T_{amb} = 0$ to 70°C	f_{03V}	-4.5	f_0	+3.0	%	C
4.7	BPF bandwidth	-3 dB; $f_0 = 38\text{ kHz}$; see Figure 5-7 on page 8	B		3.8		kHz	C

*) Type means: A = 100% tested, B = 100% correlation tested, C = Characterized on samples, D = Design parameter

- Notes:
1. BER = bit error rate; e.g., BER = 5% means that with P = 20 at the input pin 19...21 pulses can appear at the pin OUT
 2. After transformation of input current into voltage

4. Electrical Characteristics, 5-V Operation

$T_{amb} = -25^{\circ}\text{C}$ to $+85^{\circ}\text{C}$, $V_S = 4.5\text{V}$ to 5.5V unless otherwise specified.

No.	Parameters	Test Conditions	Symbol	Min.	Typ.	Max.	Unit	Type*
5	Supply							
5.1	Supply-voltage range		V_S	4.5	5.0	5.5	V	C
5.2	Supply current	$I_{IN} = 0$	I_S	0.9	1.2	1.6	mA	B
6	Output							
6.1	Internal pull-up resistor	$T_{amb} = 25^{\circ}\text{C}$ see Figure 5-10 on page 9	R_{PU}		40		k Ω	A
6.2	Output voltage low	$R_2 = 2.4\text{ k}\Omega$ see Figure 5-10 on page 9	V_{OL}			250	mV	B
6.3	Output voltage high		V_{OH}	$V_S - 0.25$		V_S	V	B
6.4	Output current clamping	$R_2 = 0$ see Figure 5-10 on page 9	I_{OCL}		8		mA	B
7	Input							
7.1	Input DC current	$V_{IN} = 0$ see Figure 5-10 on page 9	I_{IN_DCMAX}	-400			μA	C
7.2	Input DC current see Figure 5-4 on page 7	$V_{IN} = 0$; $V_S = 5\text{V}$ $T_{amb} = 25^{\circ}\text{C}$	I_{IN_DCMAX}		-700		μA	B
7.3	Minimum detection threshold current see Figure 5-2 on page 6	Test signal: see Figure 5-9 on page 9 $V_S = 5\text{V}$	I_{Eemin}		-1000		pA	B
7.4	Minimum detection threshold current with AC current disturbance $I_{IN_AC100} = 3\text{ }\mu\text{A}$ at 100 Hz	$T_{amb} = 25^{\circ}\text{C}$ $I_{IN_DC} = 1\text{ }\mu\text{A}$ square pp burst N = 16 $f = f_0$; $t_{PER} = 10\text{ ms}$ see Figure 5-8 on page 8 BER = 50 ⁽¹⁾	I_{Eemin}		-2500		pA	C

*) Type means: A = 100% tested, B = 100% correlation tested, C = Characterized on samples, D = Design parameter

- Notes:
1. BER = bit error rate; e.g., BER = 5% means that with P = 20 at the input pin 19...21 pulses can appear at the pin OUT
 2. After transformation of input current into voltage

4. Electrical Characteristics, 5-V Operation (Continued)

$T_{amb} = -25^{\circ}\text{C}$ to $+85^{\circ}\text{C}$, $V_S = 4.5\text{V}$ to 5.5V unless otherwise specified.

No.	Parameters	Test Conditions	Symbol	Min.	Typ.	Max.	Unit	Type*
7.5	Maximum detection threshold current with $V_{IN} > 0\text{V}$	Test signal: see Figure 5-9 on page 9 $V_S = 5\text{V}$, $T_{amb} = 25^{\circ}\text{C}$ $I_{IN_DC} = 1\ \mu\text{A}$ square pp burst N = 16 $f = f_0$; $t_{PER} = 10\ \text{ms}$ see Figure 5-8 on page 8 BER = 5% ⁽¹⁾	I_{Eemax}	-500			μA	D
8	Controlled Amplifier and Filter							
8.1	Maximum value of variable gain (CGA)	$V_S = 5\text{V}$, $T_{amb} = 25^{\circ}\text{C}$	G_{VARMAX}		50		dB	D
8.2	Minimum value of variable gain (CGA)	$V_S = 5\text{V}$, $T_{amb} = 25^{\circ}\text{C}$	G_{VARMIN}		-6		dB	D
8.3	Total internal amplification ⁽²⁾	$V_S = 5\text{V}$, $T_{amb} = 25^{\circ}\text{C}$	G_{MAX}		72		dB	D
8.4	Resulting center frequency fusing accuracy	f_0 fused at $V_S = 3\text{V}$ $V_S = 5\text{V}$, $T_{amb} = 25^{\circ}\text{C}$	f_{05V}		$f_{03V-FUSE} + 0.5$		%	C

*) Type means: A = 100% tested, B = 100% correlation tested, C = Characterized on samples, D = Design parameter

- Notes:
1. BER = bit error rate; e.g., BER = 5% means that with P = 20 at the input pin 19...21 pulses can appear at the pin OUT
 2. After transformation of input current into voltage

4.1 Reliability

Electrical qualification (1000h at 150°C) in molded SO8 plastic package

5. Typical Electrical Curves at $T_{amb} = 25^{\circ}\text{C}$

Figure 5-1. I_{Eemin} versus I_{IN_DC} , $V_S = 3V$

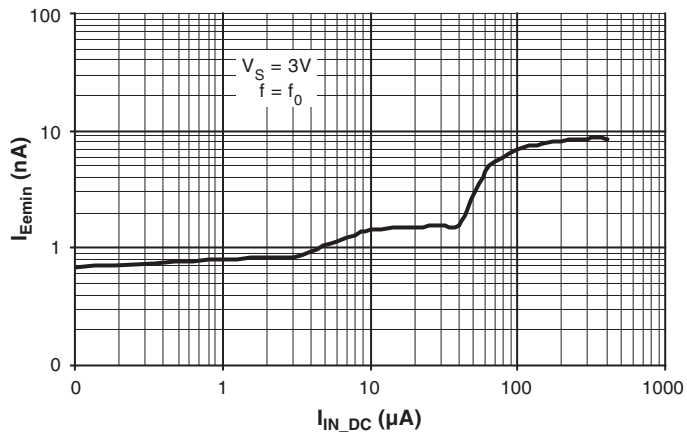

Figure 5-2. I_{Eemin} versus I_{IN_DC} , $V_S = 5V$

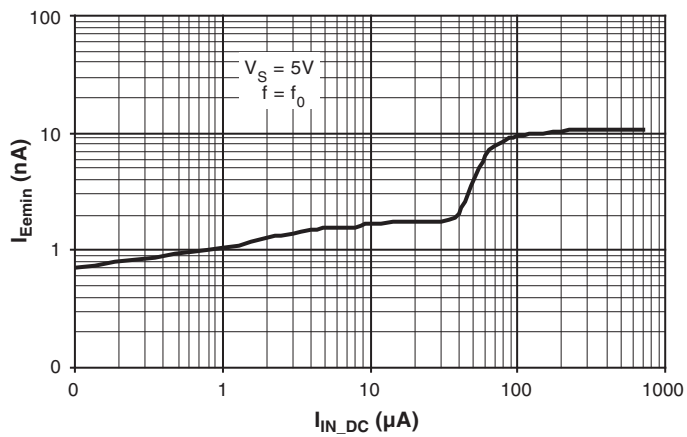

Figure 5-3. V_{IN} versus I_{IN_DC} , $V_S = 3V$

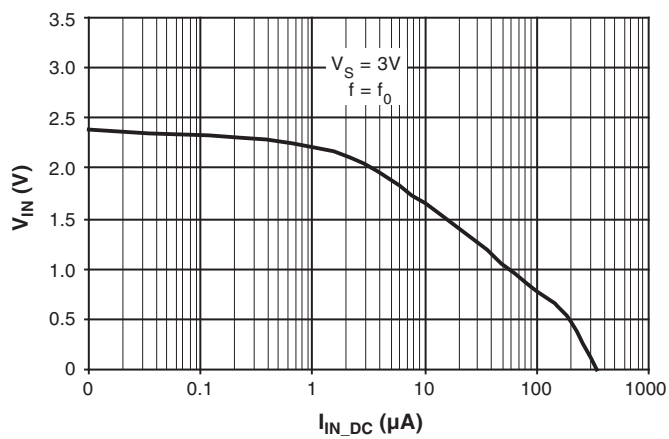

Figure 5-4. V_{IN} versus I_{IN_DC} , $V_S = 5V$

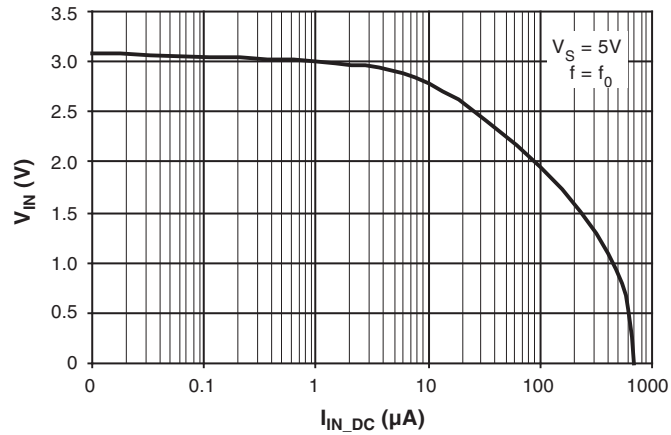

Figure 5-5. Data Transmission Rate, $V_S = 3V$

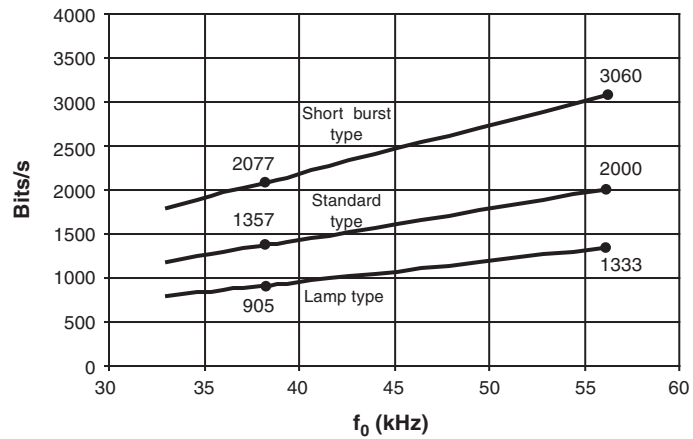

Figure 5-6. Data Transmission Rate, $V_S = 5V$

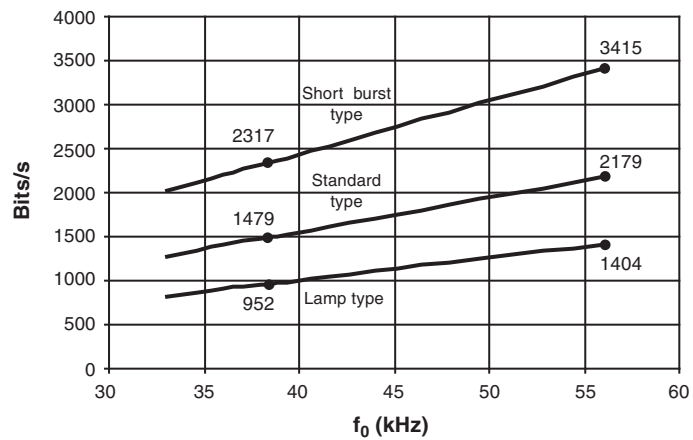
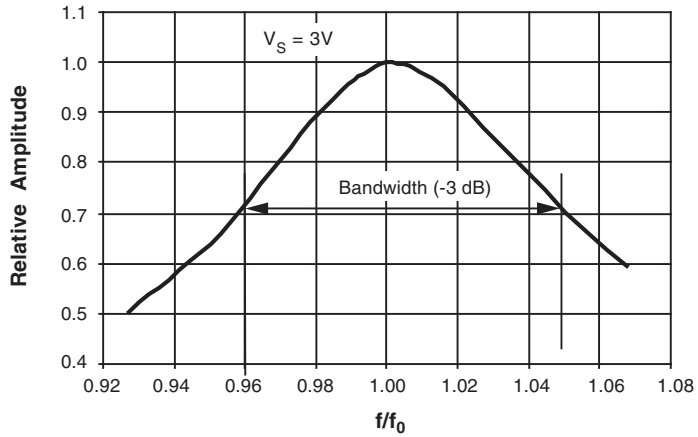

Figure 5-7. Typical Bandpass Curve



$$Q = f_0/B; B \rightarrow -3 \text{ dB values}$$

$$\text{Example: } Q = 1/(1.047 - 0.954) = 11$$

Figure 5-8. Illustration of Used Terms, Example: $f = 33 \text{ kHz}$, burst with 16 pulses, 16 periods

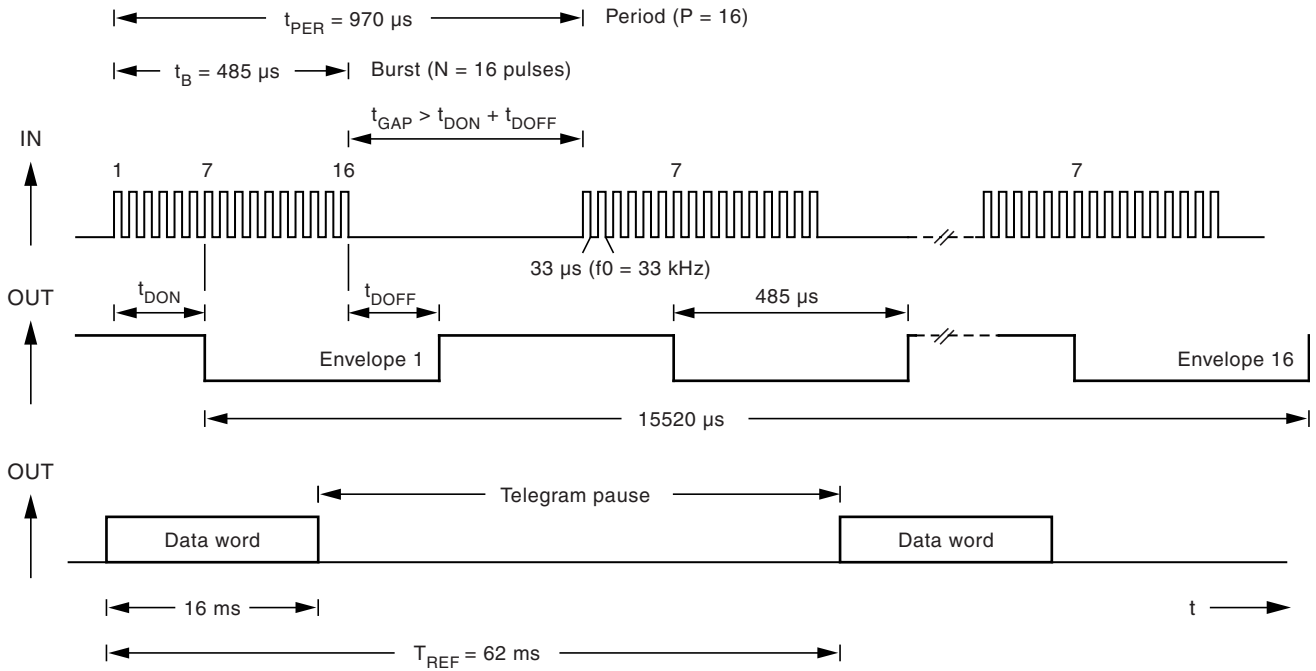

Figure 5-9. Test Circuit

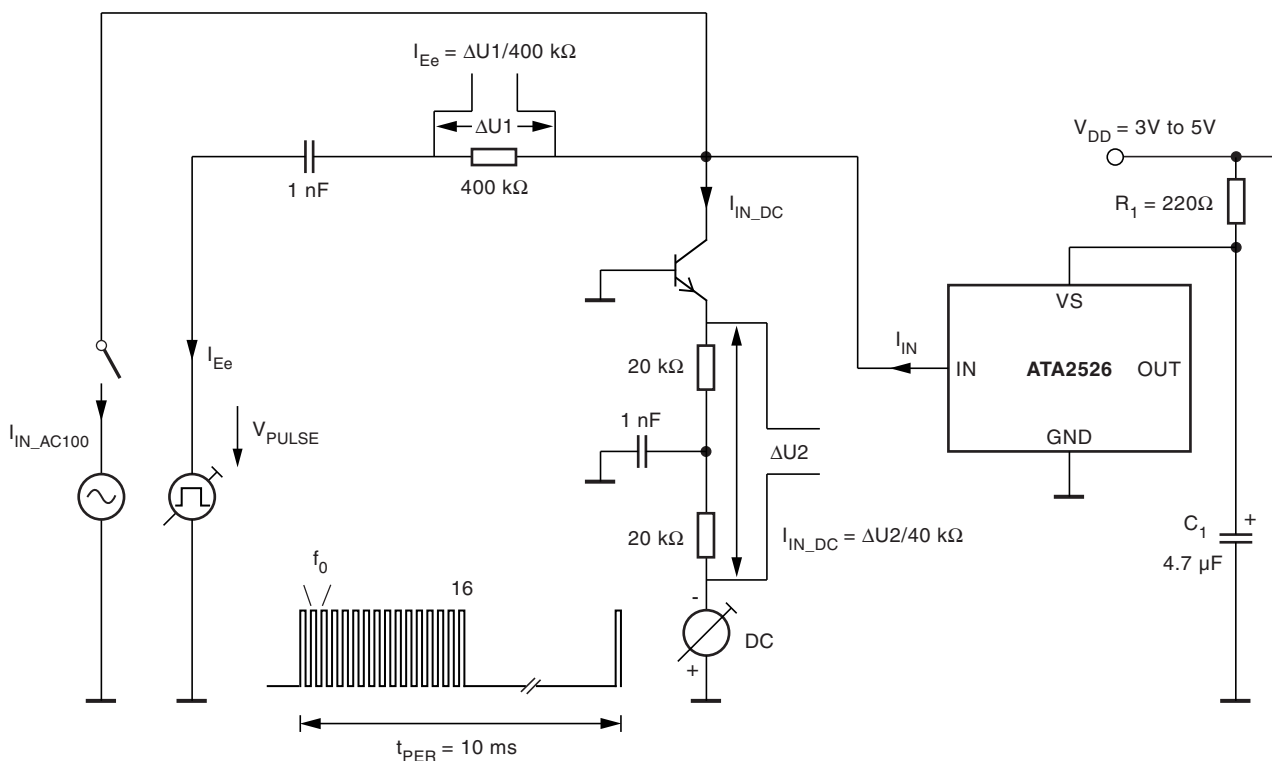
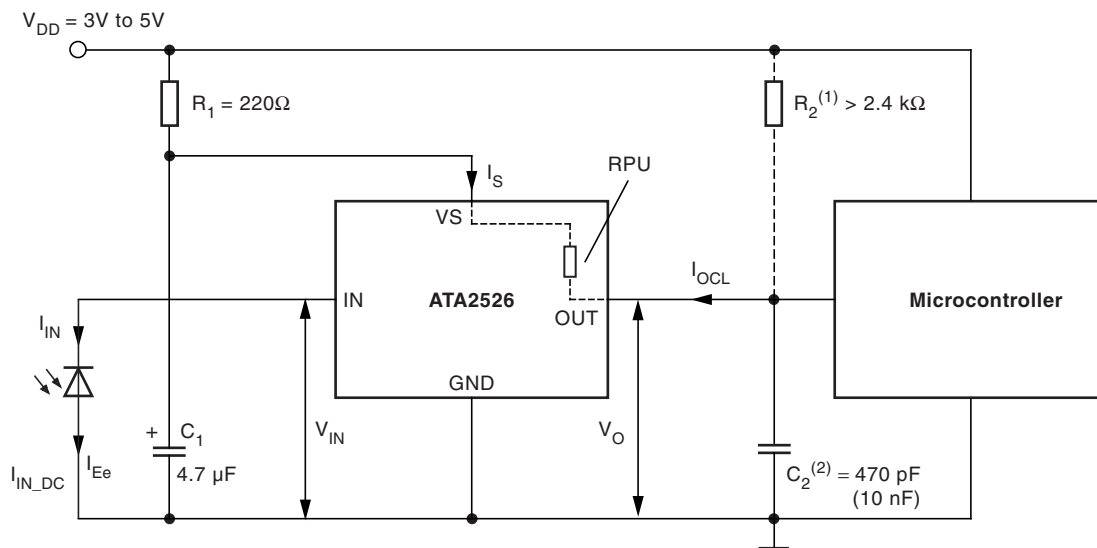

Figure 5-10. Application Circuit



(1) Optional

(2) The value of C_2 is dimensioned for the short burst type ATA2526P7xx. For the other types C_2 can be omitted.

In case of an optional resistor $R_2 > 2.4 \text{ k}\Omega$ the value of C_2 must be increased to $C_2 = 10 \text{ nF}$. For the other types $C_2 = 470 \text{ pF}$ is sufficient.

6. Chip Dimensions

Figure 6-1. Chip Size in μm

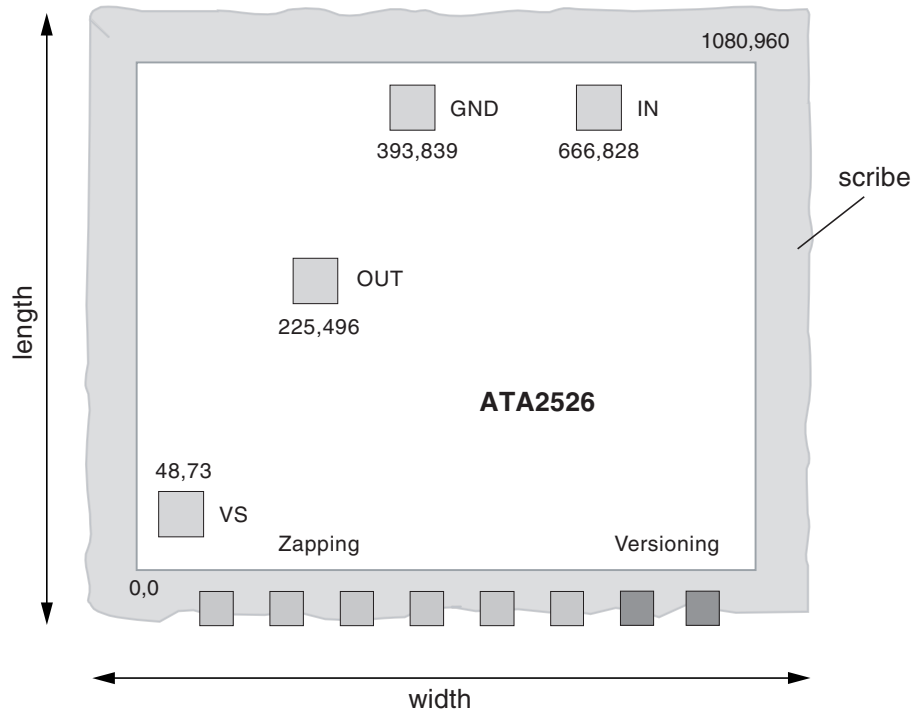

Note: Pad coordinates are given for lower left corner of the pad in μm from the origin 0,0

Dimensions	Length inclusive scribe	1.04 mm
	Width inclusive scribe	1.20 mm
	Thickness	$290 \mu \pm 5\%$
	Pads	$80 \mu \times 80 \mu$
	Fusing pads	$60 \mu \times 60 \mu$
Pad metallurgy	Material	$\text{AlCu/AlSiTi}^{(1)}$
	Thickness	$0.8 \mu\text{m}$
Finish	Material	$\text{Si}_3\text{N}_4/\text{SiO}_2$
	Thickness	$0.7/0.3 \mu\text{m}$

Note: 1. Value depends on manufacture location.

7. Ordering Information

Delivery: unsawn wafers (DDW) in box

Extended Type Number	D ⁽²⁾	Type
ATA2526S1xx ⁽¹⁾ C-DDW	2175	Standard type: ≥ 10 pulses, high data rate
ATA2526S3xx ⁽¹⁾ C-DDW	1400	Lamp type: ≥ 10 pulses, enhanced suppression of disturbances, secure data transmission
ATA2526S7xx ⁽¹⁾ C-DDW	3415	Short burst type: ≥ 6 pulses, highest data rate

- Notes:
- xx means carrier frequency value (33, 36, 37, 38 or 40 kHz and 56 kHz)
 - Maximum data transmission rate up to bits/s with $f_0 = 56$ kHz, $V_S = 5$ V (see [Figure 5-6 on page 7](#))

7.1 Pad Layout

Figure 7-1. Pad Layout

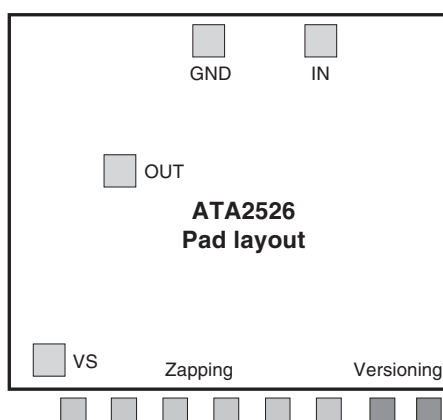

Table 7-1. Pin Description

SYMBOL	FUNCTION
OUT	Data output
VS	Supply voltage
GND	GND
IN	Input pin diode
Zapping	f_0 adjust
Versioning	Type adjust

8. Revision History

Please note that the following page numbers referred to in this section refer to the specific revision mentioned, not to this document.

Revision No.	History
4905F-AUTO-05/10	<ul style="list-style-type: none"> • Thermal Resistance table deleted • Pin columns in Electrical Characteristics tables deleted
4905E-AUTO-09/09	<ul style="list-style-type: none"> • Put datasheet in newest template • Section 8 “Ordering Information” on page 12 changed
4905D-AUTO-10/06	<ul style="list-style-type: none"> • Features on page 1 changed • Applications on page 1 changed • Section 1 “Description” on page 1 changed • Section 2 “Pin Configuration” on page 2 changed • Number 2.2, 3.3 and 3.4 of Section 5 “Electrical Characteristics, 3-V Operation” on pages 3 to 4 changed • Number 7.3, 7.4 and 8.4 of Section 5 “Electrical Characteristics, 3-V Operation” on page 5 to 6 changed • Section 6.1 “ESD” on page 6 deleted • Figure 7-10 “Application Circuit” on page 10 changed • Section 9 “Ordering Information” on page 12 changed • Rename Figure 9-1 on page 12
4905C-AUTO-04/06	<ul style="list-style-type: none"> • Section 9 “Ordering Information” on page 12 changed
4905B-AUTO-04/06	<ul style="list-style-type: none"> • Put datasheet in a new template • Section 8 “Chip Dimensions” on page 11 changed



Headquarters

Atmel Corporation
2325 Orchard Parkway
San Jose, CA 95131
USA
Tel: 1(408) 441-0311
Fax: 1(408) 487-2600

International

Atmel Asia
Unit 1-5 & 16, 19/F
BEA Tower, Millennium City 5
418 Kwun Tong Road
Kwun Tong, Kowloon
Hong Kong
Tel: (852) 2245-6100
Fax: (852) 2722-1369

Atmel Europe
Le Krebs
8, Rue Jean-Pierre Timbaud
BP 309
78054
Saint-Quentin-en-Yvelines Cedex
France
Tel: (33) 1-30-60-70-00
Fax: (33) 1-30-60-71-11

Atmel Japan
9F, Tonetsu Shinkawa Bldg.
1-24-8 Shinkawa
Chuo-ku, Tokyo 104-0033
Japan
Tel: (81) 3-3523-3551
Fax: (81) 3-3523-7581

Product Contact

Web Site
www.atmel.com

Technical Support
ir_control@atmel.com

Sales Contact
www.atmel.com/contacts

Literature Requests
www.atmel.com/literature

Disclaimer: The information in this document is provided in connection with Atmel products. No license, express or implied, by estoppel or otherwise, to any intellectual property right is granted by this document or in connection with the sale of Atmel products. **EXCEPT AS SET FORTH IN ATMEL'S TERMS AND CONDITIONS OF SALE LOCATED ON ATMEL'S WEB SITE, ATMEL ASSUMES NO LIABILITY WHATSOEVER AND DISCLAIMS ANY EXPRESS, IMPLIED OR STATUTORY WARRANTY RELATING TO ITS PRODUCTS INCLUDING, BUT NOT LIMITED TO, THE IMPLIED WARRANTY OF MERCHANTABILITY, FITNESS FOR A PARTICULAR PURPOSE, OR NON-INFRINGEMENT. IN NO EVENT SHALL ATMEL BE LIABLE FOR ANY DIRECT, INDIRECT, CONSEQUENTIAL, PUNITIVE, SPECIAL OR INCIDENTAL DAMAGES (INCLUDING, WITHOUT LIMITATION, DAMAGES FOR LOSS OF PROFITS, BUSINESS INTERRUPTION, OR LOSS OF INFORMATION) ARISING OUT OF THE USE OR INABILITY TO USE THIS DOCUMENT, EVEN IF ATMEL HAS BEEN ADVISED OF THE POSSIBILITY OF SUCH DAMAGES.** Atmel makes no representations or warranties with respect to the accuracy or completeness of the contents of this document and reserves the right to make changes to specifications and product descriptions at any time without notice. Atmel does not make any commitment to update the information contained herein. Unless specifically provided otherwise, Atmel products are not suitable for, and shall not be used in, automotive applications. Atmel's products are not intended, authorized, or warranted for use as components in applications intended to support or sustain life.

© 2009 Atmel Corporation. All rights reserved. Atmel®, logo and combinations thereof, and others are registered trademarks or trademarks of Atmel Corporation or its subsidiaries. Other terms and product names may be trademarks of others.