

Features

- 16 Mbit SRAM Multi Chip Module
- Allows 32-, 16- or 8-bit access configuration
- Operating Voltage: 3.3V \pm 0.3V
- Access Time
 - 20 ns
 - 18 ns
- Power Consumption
 - Active: 620 mW per byte (Max) @ 18ns - 415 mW per byte (Max) @ 50ns ⁽¹⁾
 - Standby: 13 mW (Typ)
- Military Temperature Range: -55 to +125°C
- TTL-Compatible Inputs and Outputs
- Asynchronous
- Die manufactured on Atmel 0.25 μ m Radiation Hardened Process
- No Single Event Latch Up below LET Threshold of 80 MeV/mg/cm²@125°C
- Tested up to a Total Dose of 300 krad (Si) according to MIL-STD-883 Method 1019
- ESD better than 4000V
- Quality Grades:
 - QML-Q or V
 - ESCC
- 950 Mils Wide MQFP68 Package
- Mass : 8.5 grams

Note: 1. Only for AT68166H-18. 450mW for AT68166H-20.

Description

The AT68166H is a 16Mbit SRAM packaged in a hermetic Multi Chip Module (MCM) for space applications.

The AT68166H MCM incorporates four 4Mbit AT60142H SRAM dice. It can be organized as either one bank of 512Kx8, two banks of 512Kx16 or four banks of 512Kx8. It combines rad-hard capabilities, a latch-up threshold of 80MeV.cm²/mg, a Multiple Bit Upset immunity and a total dose tolerance of 300Krad, with a fast access time.

The MCM packaging technology allows a reduction of the PCB area by 50% with a weight savings of 75% compared to four 4Mbit packages.

Thanks to the small size of the 4Mbit SRAM die, Atmel has been able to accommodate the assembly of the four dice on one side of the package which facilitates the power dissipation.

The compatibility with other products allows designers to easily migrate to the Atmel AT68166H memory.

The AT68166H is powered at 3.3V.

The AT68166H is processed according to the test methods of the latest revision of the MIL-PRF-38535 or the ESCC 9000.



Rad Hard 16 MegaBit 3.3V SRAM Multi- Chip Module

AT68166H



Block Diagram

AT68166H Block Diagram

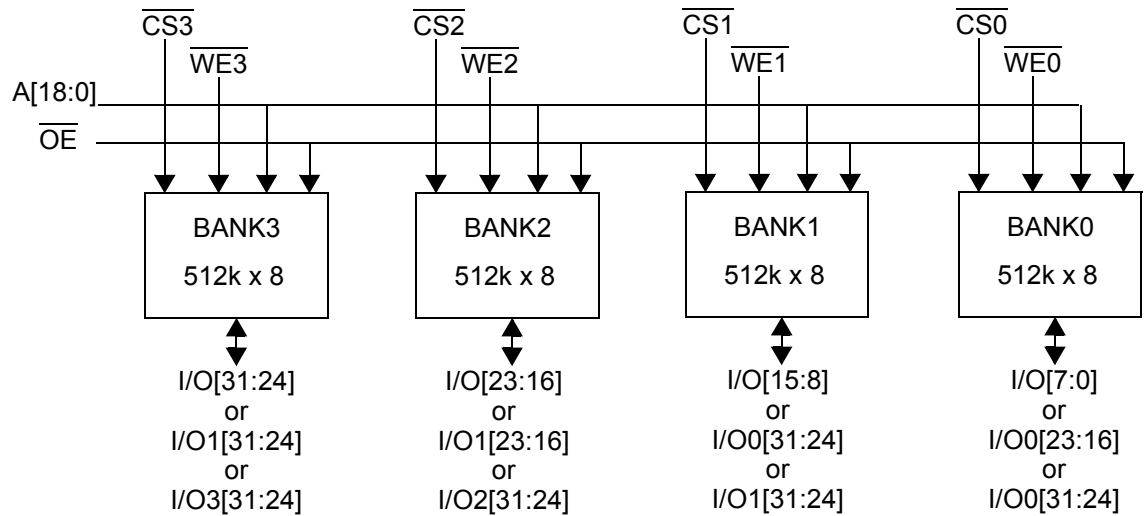

512K x 8 Bank Block Diagram (AT60142H)

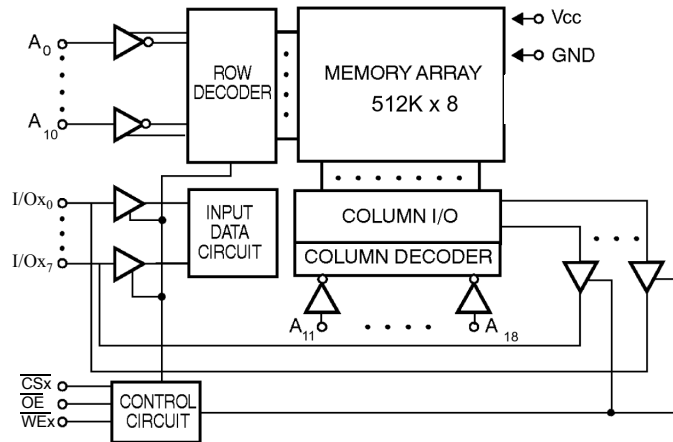

Pin Configuration

AT68166H is packaged in a MQFPT68. The pin assignment depends on the access time.

There are 2 versions as described in the table below :

Access Time	18 ns	20 ns
Package Version	YS	YM

Table 1. Pin assignment for YS & YM versions

Lead	Signal	Lead	Signal	Lead	Signal	Lead	Signal		
1	I/O0[0]	18	VCC	35	I/O3[7]	52	VCC		
2	I/O0[1]	19	A11	36	I/O3[6]	53	A10		
3	I/O0[2]	20	A12	37	I/O3[5]	54	A9		
4	I/O0[3]	21	A13	38	I/O3[4]	55	A8		
5	I/O0[4]	22	A14	39	I/O3[3]	56	A7		
6	I/O0[5]	23	A15	40	I/O3[2]	57	A6		
7	I/O0[6]	24	A16	41	I/O3[1]	58	WE0		
8	I/O0[7]	25	CS0	42	I/O3[0]	59	CS3		
9	GND	26	OE	43	GND	60	GND		
10	I/O1[0]	27	CS1	44	I/O2[7]	61	CS2		
11	I/O1[1]	28	A17	45	I/O2[6]	62	A5		
12	I/O1[2]	29	WE1	46	I/O2[5]	63	A4		
13	I/O1[3]	30	WE2	47	I/O2[4]	64	A3		
14	I/O1[4]	31	WE3	48	I/O2[3]	65	A2		
15	I/O1[5]	32	A18	49	I/O2[2]	66	A1		
16	I/O1[6]	33	YS	GND	50	I/O2[1]	67	A0	
			YM	NC					
17	I/O1[7]	34	YS	VCC	51	I/O2[0]	68	YS	VCC
			YM	NC				YM	NC

Figure 1. YM package pin assignment

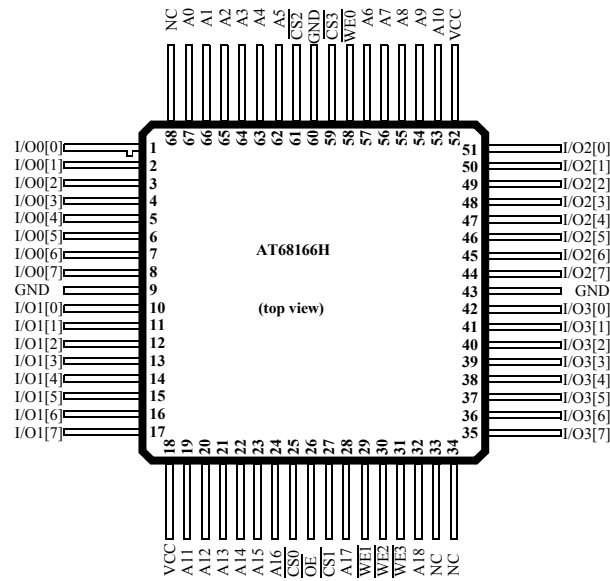

Note: NC pins are not bonded internally. So, they can be connected to GND or Vcc.

Figure 2. YS package pin assignment

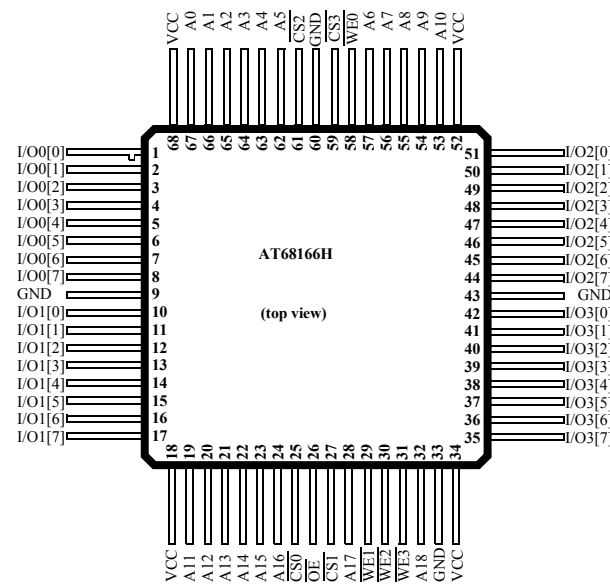

Pin Description

Table 2. Pin Names

Name	Description
A0 - A18	Address Inputs
I/O0 - I/O31	Data Input/Output
$\overline{CS0}$ - $\overline{CS3}$	Chip Select
$\overline{WE0}$ - $\overline{WE3}$	Write Enable
\overline{OE}	Output Enable
VCC	Power Supply
GND ⁽¹⁾	Ground

Note: 1. The package lid is connected to GND

Table 3. Truth Table⁽¹⁾

\overline{CSx}	\overline{WEx}	\overline{OE}	Inputs/Outputs	Mode
H	X	X	Z	Standby
L	H	L	Data Out	Read
L	L	X	Data In	Write
L	H	H	Z	Output Disable

Note: 1. L=low, H=high, X= H or L, L=high impedance.



Electrical Characteristics

Absolute Maximum Ratings*

Supply Voltage to GND Potential:	-0.5V + 4.6V
Voltage range on any input:	GND -0.5V to 4.6V
Voltage range on any output:	GND -0.5V to 4.6V
Storage Temperature:	-65°C to + 150°C
Output Current from Output Pins:	20 mA
Electrostatic Discharge Voltage:	> 4000V (MIL STD 883D Method 3015)

*NOTE:

Stresses beyond those listed under "Absolute Maximum Ratings" may cause permanent damage to the device. This is a stress rating only and functional operation of the device at these or any other conditions beyond those indicated in the operational sections of this specification is not implied.

Exposure between recommended DC operating and absolute maximum rating conditions for extended periods may affect device reliability.

Military Operating Range

Operating Voltage	Operating Temperature
3.3 ± 0.3V	-55.°C to + 125.°C

Recommended DC Operating Conditions

Parameter	Description	Min	Typ	Max	Unit
V _{CC}	Supply voltage	3.0	3.3	3.6	V
GND	Ground	0.0	0.0	0.0	V
V _{IL}	Input low voltage	GND - 0.3	0.0	0.8	V
V _{IH}	Input high voltage	2.2	–	V _{CC} + 0.3	V

Capacitance

Parameter	Description	Min	Typ	Max	Unit
C _{in} ⁽¹⁾ (OE and Ax)	Input capacitance	–	–	48	pF
C _{in} ⁽¹⁾ (CSx and WEx)	Input capacitance	–	–	12	pF
C _{io} ⁽¹⁾	I/O capacitance	–	–	12	pF

Note: 1. Guaranteed but not tested.

DC Parameters

DC Test Conditions TA = -55°C to + 125°C; V_{SS} = 0V; V_{CC} = 3.0V to 3.6V

Parameter	Description	Minimum	Typical	Maximum	Unit
IIX ⁽¹⁾	Input leakage current	-1	–	1	μA
IOZ ⁽¹⁾	Output leakage current	-1	–	1	μA
VOL ⁽²⁾	Output low voltage	–	–	0.4	V
VOH ⁽³⁾	Output high voltage	2.4	–	–	V

- Notes: 1. GND < V_{IN} < V_{CC}, GND < V_{OUT} < V_{CC} Output Disabled.
 2. V_{CC} min, -I_{OL} = 8 mA
 3. V_{CC} min, I_{OH} = -4 mA

Consumption

Symbol	Description	TAVAV/TAVAW Test Condition	AT68166H-20	AT68166H-18	Unit	Value
I _{CCSB} ⁽¹⁾	Standby Supply Current	–	10	7	mA	max
I _{CCSB1} ⁽²⁾	Standby Supply Current	–	8	6	mA	max
I _{CCOP} ⁽³⁾ Read per byte	Dynamic Operating Current	18 ns 20 ns 50 ns 1 μs	– 170 85 15	170 165 80 12	mA	max
I _{CCOP} ⁽⁴⁾ Write per byte	Dynamic Operating Current	18 ns 20 ns 50 ns 1 μs	– 150 125 110	145 140 115 105	mA	max

- Notes: 1. All CS_X ≥ V_{IH}
 2. All CS_X ≥ V_{CC} - 0.3V
 3. F = 1/T_{TAVAV}, I_{out} = 0 mA, $\overline{WEX} = \overline{OE} = V_{IH}$, V_{IN} = GND/V_{CC}, V_{CC} max.
 4. F = 1/T_{TAVAW}, I_{out} = 0 mA, $\overline{WEX} = V_{IL}$, $\overline{OE} = V_{IH}$, V_{IN} = GND/V_{CC}, V_{CC} max.

Data Retention Mode

Atmel CMOS RAM's are designed with battery backup in mind. Data retention voltage and supply current are guaranteed over temperature. The following rules insure data retention:

1. During data retention chip select \overline{CSx} must be held high within V_{CC} to $V_{CC} - 0.2V$.
2. Output Enable (\overline{OE}) should be held high to keep the RAM outputs high impedance, minimizing power dissipation.
3. During power-up and power-down transitions \overline{CSx} and \overline{OE} must be kept between $V_{CC} + 0.3V$ and 70% of V_{CC} .
4. The RAM can begin operation $> t_R$ ns after V_{CC} reaches the minimum operation voltages (3V).

Figure 3. Data Retention Timing

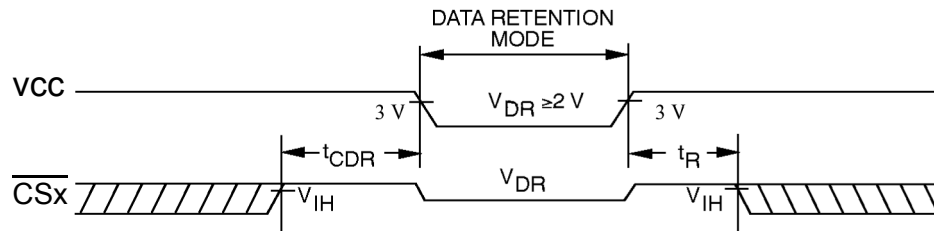

Data Retention Characteristics

Parameter	Description	Min	Typ $T_A = 25\text{C}$	Max	Unit
V_{CCDR}	V_{CC} for data retention	2.0	–	–	V
t_{CDR}	Chip deselect to data retention time	0.0	–	–	ns
t_R	Operation recovery time	$t_{AVAV}^{(1)}$	–	–	ns
$I_{CCDR}^{(2)}$	Data retention current	–	3	6 (AT68166H-20)	mA
				4.5 (AT68166H-18)	

1. $T_{AVAV} =$ Read cycle time.
2. All $CSx = V_{CC}$, $V_{IN} = GND/V_{CC}$.

AC Characteristics

Temperature Range:..... -55 +125°C
 Supply Voltage: 3.3 ±0.3V
 Input Pulse Levels: GND to 3.0V
 Input Rise and Fall Times: 3ns (10 - 90%)
 Input and Output Timing Reference Levels: 1.5V
 Output Loading I_{OL}/I_{OH} : See Figure 4

Figure 4. AC Test Loads Waveforms

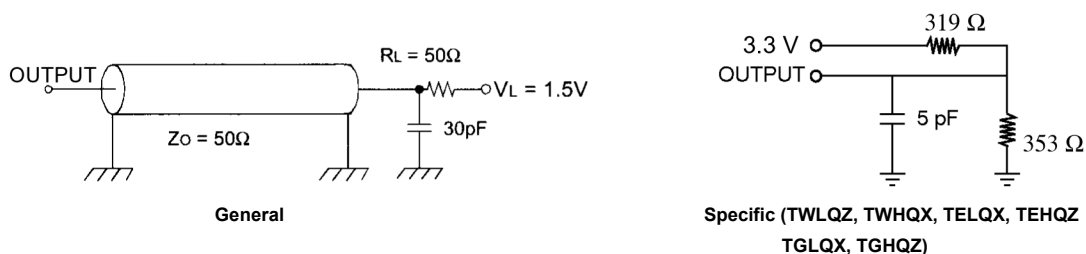

Write Cycle

Table 4. Write cycle timings⁽¹⁾

Symbol	Parameter	AT68166H-20		AT68166H-18		Unit
		min	max	min	max	
TAVAW	Write cycle time	20	-	18	-	ns
TAVWL	Address set-up time	2	-	2	-	ns
TAVWH	Address valid to end of write	14	-	11	-	ns
TDVWH	Data set-up time	9	-	8	-	ns
TELWH	\overline{CS} low to write end	12	-	12	-	ns
TWLQZ	Write low to high $Z^{(2)}$	-	10	-	8	ns
TWLWH	Write pulse width	12	-	9	-	ns
TWHAX	Address hold from end of write	0	-	0	-	ns
TWHDX	Data hold time	2	-	1	-	ns
TWHQX	Write high to low $Z^{(2)}$	5	-	3	-	ns

- Notes: 1. Timings figures applicable for 8-bit, 16-bit and 32-bit mode.
 2. Parameters guaranteed, not tested, with output loading 5 pF. (See “AC Test Loads Waveforms” on page 9.)

Write Cycle 1.

\overline{WE} Controlled, \overline{OE} High During Write

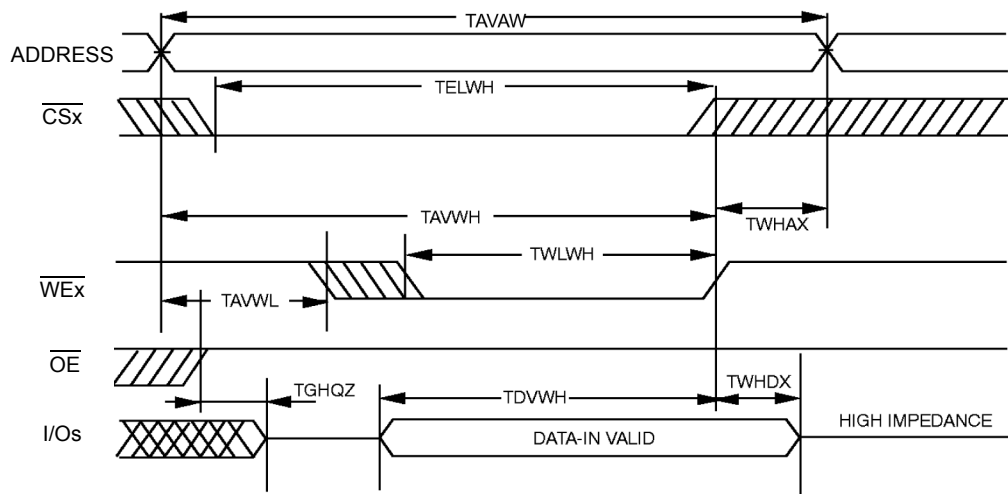

Write Cycle 2.

\overline{WE} Controlled, \overline{OE} Low

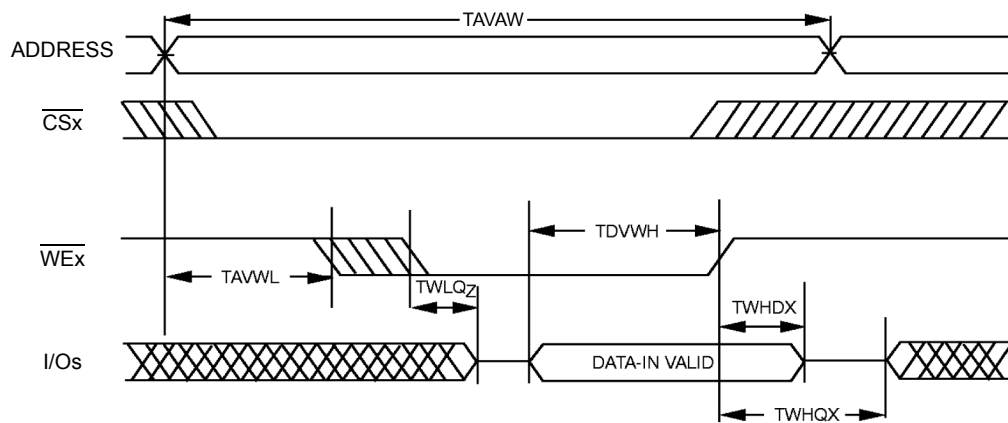

Write Cycle 3.

\overline{CS} Controlled

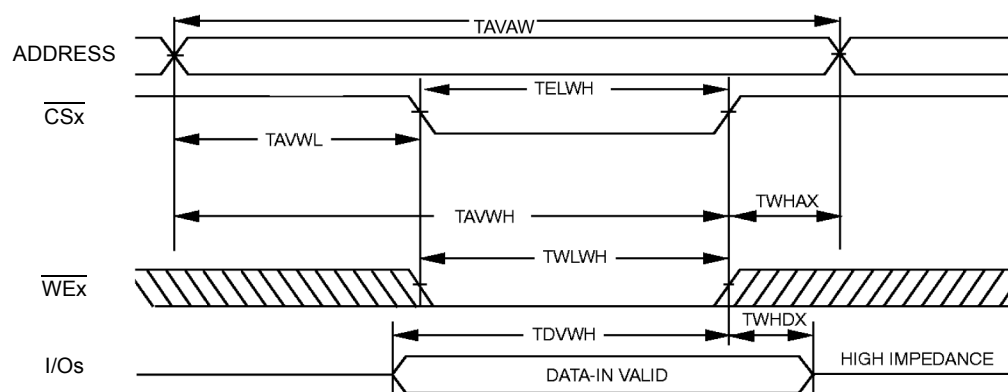

The internal write time of the memory is defined by the overlap of \overline{CS} Low and \overline{WE} LOW. Both signals must be activated to initiate a write and either signal can terminate a write by going in active mode. The data input setup and hold timing should be referenced to the active edge of the signal that terminates the write. Data out is high impedance if $\overline{OE} = V_{IH}$.

Read Cycle

Table 5. Read cycle timings⁽¹⁾

Symbol	Parameter	AT68166H-20		AT68166H-18		Unit
		min	max	min	max	
TAVAV	Read cycle time	20	-	18	-	ns
TAVQV	Address access time	-	20	-	18	ns
TAVQX	Address valid to low Z	5	-	5	-	ns
TELQV	Chip-select access time	-	20	-	18	ns
TELQX	\overline{CS} low to low Z ⁽²⁾	5	-	5	-	ns
TEHQZ	\overline{CS} high to high Z ⁽²⁾	-	9	-	8	ns
TGLQV	Output Enable access time	-	11	-	8	ns
TGLQX	\overline{OE} low to low Z ⁽²⁾	2	-	2	-	ns
TGHQZ	\overline{OE} high to high Z ⁽²⁾	-	9	-	8	ns

- Notes: 1. Timings figures applicable for 8-bit, 16-bit and 32-bit mode.
 2. Parameters guaranteed, not tested, with output loading 5 pF. (See “AC Test Loads Waveforms” on page 9.)

Read Cycle 1

Address Controlled ($\overline{CS} = \overline{OE} = V_{IL}$, $\overline{WE} = V_{IH}$)

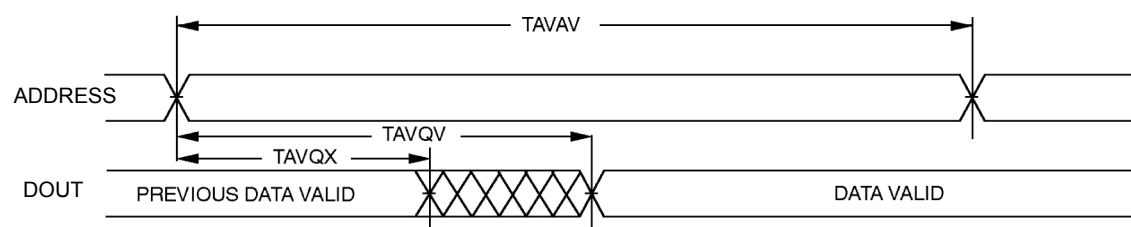

Read Cycle 2

Chip Select Controlled ($\overline{WE} = V_{IH}$)

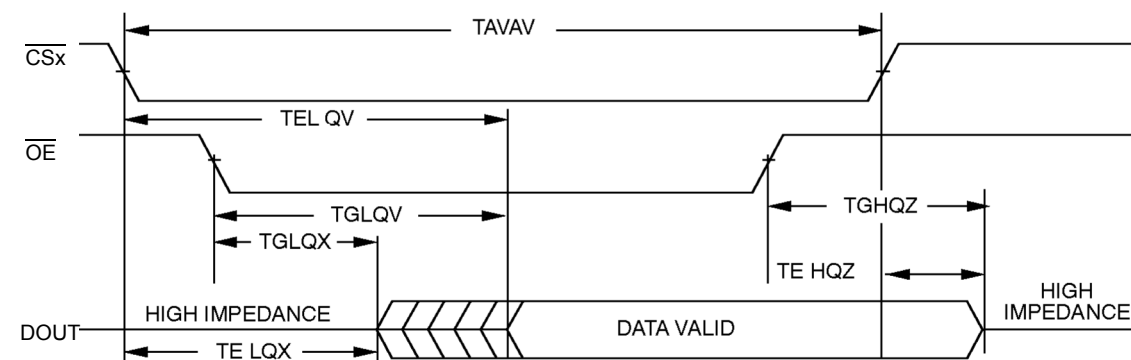

Typical Applications

This section shows standard implementations of the AT68166H in applications.

32-bit mode application

When used on a 32-bit (word) application, the module shall be connected as follow :

- The 32 lines of data are connected to distinct data lines
- The four \overline{CS}_x are connected together and linked to a single host \overline{CS} output
- Each of the four \overline{WE}_x is connected to a dedicated \overline{WE} line on the host to allow byte, half word and word format write.

Figure 5. 32-bit typical application (one SRAM bank)

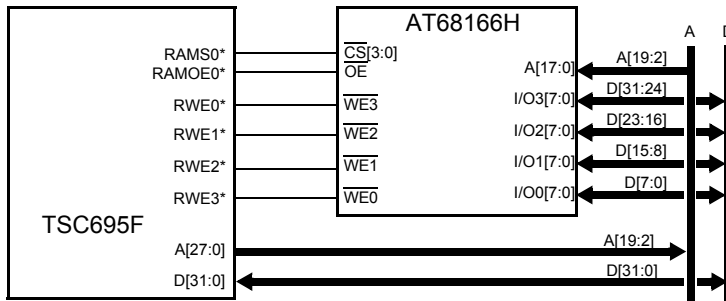

16-bit mode application

When used on a 16-bit (half word) application, the module can be connected as presented in the following figure. This allows the use of a single AT68166H part for two SRAM memory banks. All input controls of the AT68166H not used in the application shall be pulled-up.

Figure 6. 16-bit typical application (two SRAM banks)

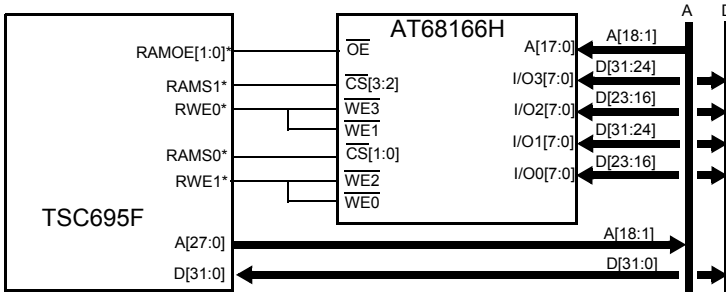

8-bit mode application

When used on a 8-bit (byte) application, the module can be connected as presented in the following figure. This allows the use of a single AT68166H part for up to four SRAM memory banks. All input controls of the AT68166H not used in the application shall be pulled-up.

Figure 7. 8-bit typical application (four SRAM banks)

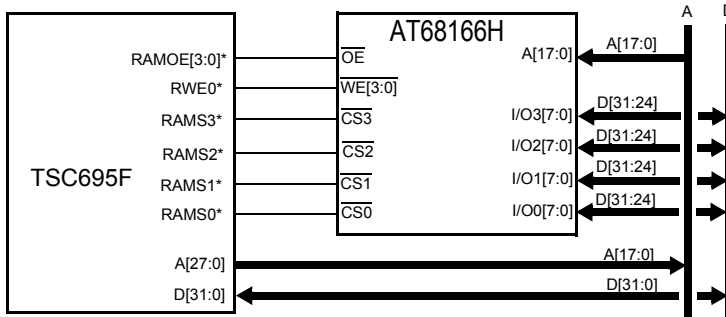

Ordering Information

Part Number	Temperature Range	Speed	Package	Flow
AT68166H-YM20-E	25-C	20 ns	MQFPT68	Engineering Samples
5962-0622908QXC	-55 to +125-C	20 ns	MQFPT68	QML Q
5962-0622908VXC	-55 to +125-C	20 ns	MQFPT68	QML V
5962R0622908VXC	-55 to +125-C	20 ns	MQFPT68	QML V RHA
AT68166H-YM20-SCC ⁽¹⁾	-55 to +125-C	20 ns	MQFPT68	ESCC
AT68166H-YS18-E	25°C	18 ns	MQFPT68	Engineering Samples
5962-0622906QYC	-55° to +125°C	18 ns	MQFPT68	QML Q
5962-0622906VYC	-55° to +125°C	18 ns	MQFPT68	QML V
5962R0622906VYC	-55° to +125°C	18 ns	MQFPT68	QML V RHA
AT68166H-YS18-SCC ⁽¹⁾	-55° to +125°C	18 ns	MQFPT68	ESCC

1. Will be replaced by ESCC part number when available.

Package Drawing

68-lead Quad Flat Pack (950 Mils) with non conductive tie bar

68 LEADS FLAT PACK CERAMIC TIE BAR

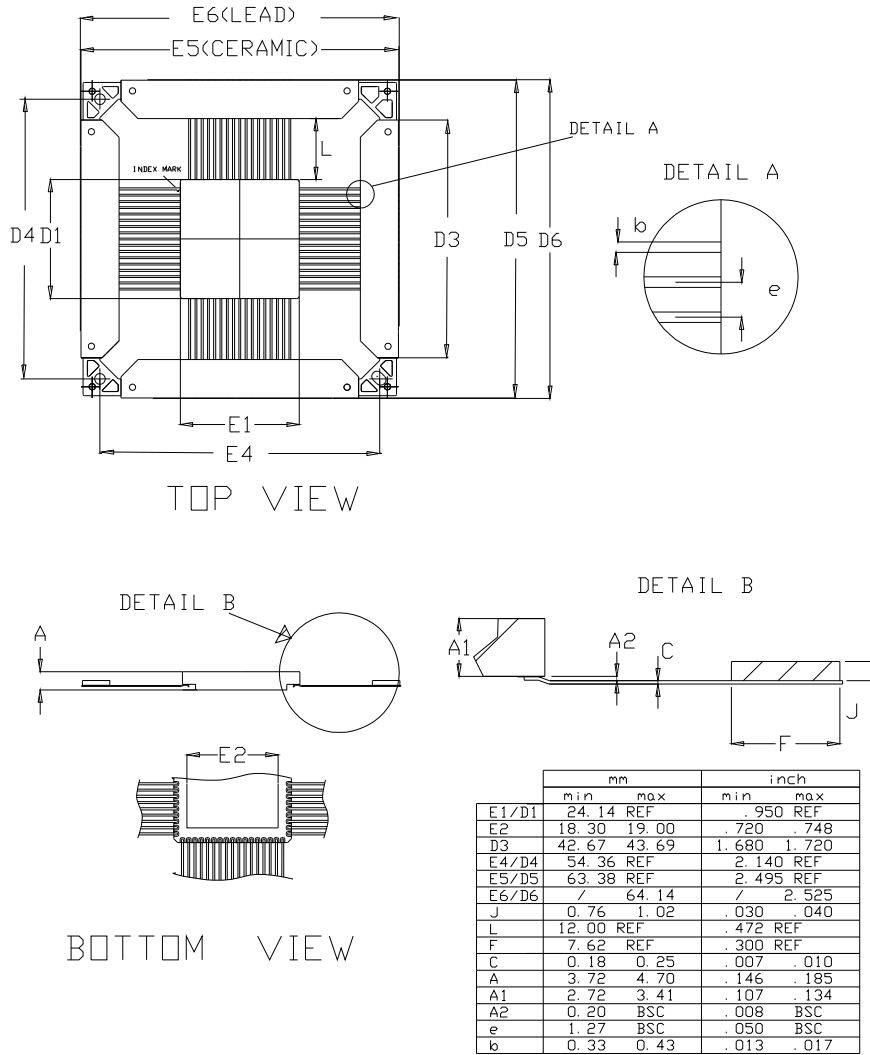

- Note:
1. Lid is connected to Ground.
 2. YM and YS package drawings are identical.

Document Revision History

Creation from AT66168F without any change.

Changes from Rev. A to Rev. B

Page 2 : AT68166H Block Diagram updated

Page 4 : package drawings updated

Page 12 : typical application figures updated

Page 13 : SMD part-numbers added for 18 ns versions (YS package)

Changes from Rev. B to Rev. C

Page 2 : AT68166H Block Diagram updated

Page 12 : typical application figures updated

Page 13 : SMD part-numbers added for 20 ns versions (YM package)



Headquarters

Atmel Corporation
2325 Orchard Parkway
San Jose, CA 95131
USA
Tel: 1(408) 441-0311
Fax: 1(408) 487-2600

International

Atmel Asia
Room 1219
Chinachem Golden Plaza
77 Mody Road Tsimshatsui
East Kowloon
Hong Kong
Tel: (852) 2721-9778
Fax: (852) 2722-1369

Atmel Europe
Le Krebs
8, Rue Jean-Pierre Timbaud
BP 309
78054 Saint-Quentin-en-
Yvelines Cedex
France
Tel: (33) 1-30-60-70-00
Fax: (33) 1-30-60-71-11

Atmel Japan
9F, Tonetsu Shinkawa Bldg.
1-24-8 Shinkawa
Chuo-ku, Tokyo 104-0033
Japan
Tel: (81) 3-3523-3551
Fax: (81) 3-3523-7581

Product Contact

Web Site
www.atmel.com

Technical Support
Enter Product Line E-mail

Sales Contact
www.atmel.com/contacts

Literature Requests
www.atmel.com/literature

Disclaimer: The information in this document is provided in connection with Atmel products. No license, express or implied, by estoppel or otherwise, to any intellectual property right is granted by this document or in connection with the sale of Atmel products. **EXCEPT AS SET FORTH IN ATMEL'S TERMS AND CONDITIONS OF SALE LOCATED ON ATMEL'S WEB SITE, ATMEL ASSUMES NO LIABILITY WHATSOEVER AND DISCLAIMS ANY EXPRESS, IMPLIED OR STATUTORY WARRANTY RELATING TO ITS PRODUCTS INCLUDING, BUT NOT LIMITED TO, THE IMPLIED WARRANTY OF MERCHANTABILITY, FITNESS FOR A PARTICULAR PURPOSE, OR NON-INFRINGEMENT. IN NO EVENT SHALL ATMEL BE LIABLE FOR ANY DIRECT, INDIRECT, CONSEQUENTIAL, PUNITIVE, SPECIAL OR INCIDENTAL DAMAGES (INCLUDING, WITHOUT LIMITATION, DAMAGES FOR LOSS OF PROFITS, BUSINESS INTERRUPTION, OR LOSS OF INFORMATION) ARISING OUT OF THE USE OR INABILITY TO USE THIS DOCUMENT, EVEN IF ATMEL HAS BEEN ADVISED OF THE POSSIBILITY OF SUCH DAMAGES.** Atmel makes no representations or warranties with respect to the accuracy or completeness of the contents of this document and reserves the right to make changes to specifications and product descriptions at any time without notice. Atmel does not make any commitment to update the information contained herein. Unless specifically provided otherwise, Atmel products are not suitable for, and shall not be used in, automotive applications. Atmel's products are not intended, authorized, or warranted for use as components in applications intended to support or sustain life.

©2009 Atmel Corporation. All rights reserved. Atmel®, logo and combinations thereof, and Everywhere You Are® are the trademarks or registered trademarks, of Atmel Corporation or its subsidiaries. Other terms and product names may be trademarks of others.