

Features

- Also known as SMCS332SpW
- 3 identical bidirectional SpaceWire links allowing
 - full duplex communication
 - transmit rate from 1.25 up to 200 Mbit/s in each direction
- Derived from the TSS901E-SMCS332 triple IEEE 1355 high speed controller
 - Known anomalies of the TSS901E chip corrected
 - Slightly different startup behavior
- COmmunication Memory Interface (COMI)
 - autonomous accesses to a communication memory
- HOst Control Interface (HOCI)
 - gives read/write accesses to the AT7911E configuration registers
 - gives read/write accesses to the SpaceWire channels
- Arbitration unit
 - Allows two AT7911E to share one Dual Port RAM without external arbitration
- Scalable databus width
 - 8/16/32 bit width available
 - allows flexible integration with any CPU type
- Allows Little endian and Big endian configuration
- Performance
 - At 3.3V: 100 Mbit/s full duplex communication in each direction
 - At 5V: 200 Mbit/s full duplex communication in each direction
- Operating range
 - Voltages
 - 3V to 3.6V
 - 4.5V to 5.5V
 - Temperature
 - - 55°C to +125°C
- Maximum Power consumption
 - At 3.6V with a 15MHz clock : 0.4 W
 - At 5.5V with a 25 MHz clock : 1.7 W
- Radiation Performance
 - Total dose tested successfully up to 50 Krad (Si)
 - No single event latchup below a LET of 80 MeV/mg/cm2
- ESD better than 2000V
- Quality Grades :
 - QML-Q or V with SMD
- Package : 196 pins MQFPL
- Mass : 12grams



Triple SpaceWire links High Speed Controller

AT7911E





1. Description

The AT7911E provides an interface between three SpaceWire links according to the SpaceWire standard ECSS-E-50-12A specification and a data processing node consisting of a Control Processing Unit and a communication data memory.

The AT7911E was designed by EADS Astrium in Germany under the name 'SMCS332SpW' for "Scalable Multi-channel Communication Subsystem for SpaceWire". It is manufactured using the SEU hardened cell library from Atmel MG2RT CMOS 0.5µm radiation tolerant sea of gates technology.

For any technical question relative to the functionality of the AT7911E please contact Atmel technical support at assp-applab.hotline@nto.atmel.com.

This document shall be read in conjunction with **EADS Astrium 'SMCS332SpW User Manual'**. The complete user manual of the AT7911E also called SMCS332SpW is available at www.atmel.com.

The AT7911E provides hardware supported execution of the major parts of the interprocessor communication protocol, particularly:

- Transfer of data between two nodes of a multi-processor system with minimal host CPU intervention
- Execution of simple commands to provide basic features for system control functions
- Provision of fault tolerant features.

Target applications are heterogeneous multi-processor systems supported by scalable interfaces including the little/big endian byte swapping. The AT7911E connects modules with different processors (e.g. TSC695F, AT697E and others). Any kind of network topology could be realized through the high speed point-to-point SpaceWire links (see the section 'Applications').

It can also be used for modules without any communication features such as special image compression chips, some signal processors, application specific programmable logic or mass memory.

The AT7911E may also be used in single board systems where standardised high speed interfaces are needed and systems containing "non-intelligent" modules such as A/D-converter or sensor interfaces which can be assembled with the AT7911E thanks to the "control by link" feature.

Figure 1. AT7911E Block Diagram

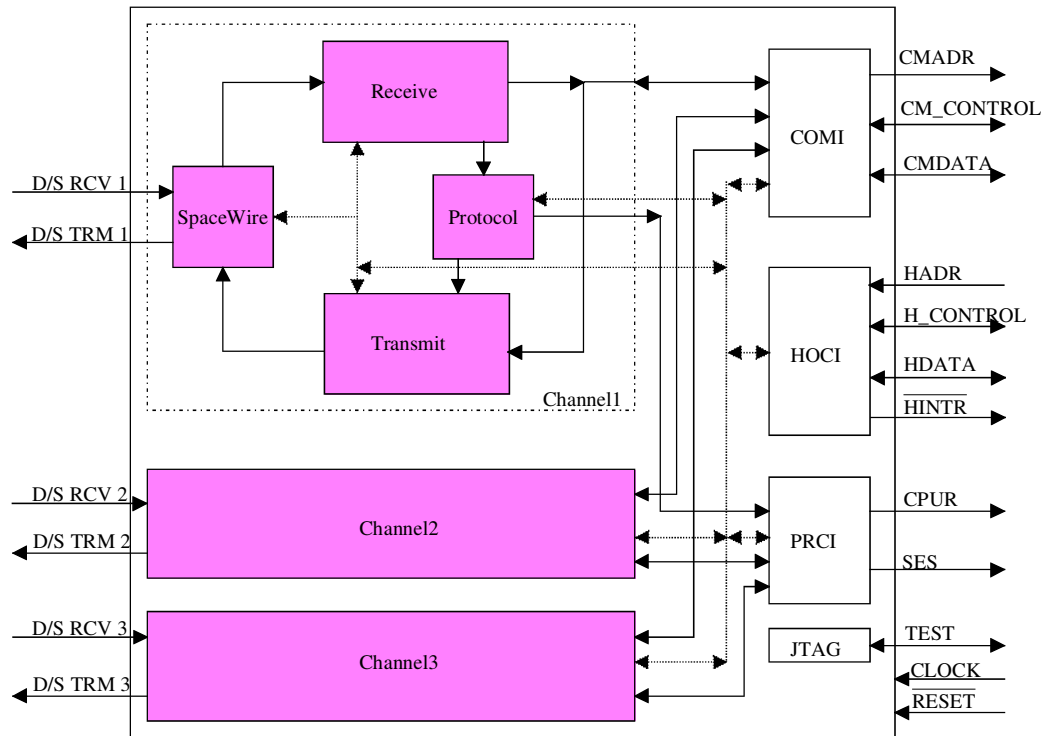

The AT7911E is supported by VSPWorks from Wind River, a commercially available distributed real-time kernel. It is a multi-tasking as well as a multi-processor Operating System. The main goals are to enable programming at a higher level to configure and to perform communication and to administer the tasks on a board with multiple processes running in parallel.

The VSPWorks kernel supports multiple processors and application specific chips, e.g. the TSC21020, the Sparc TSC695F, the AT697 etc.... Thus it is possible to run a heterogeneous multiprocessor system with a single Operating System without consideration of the hardware platform.

2. Pin Configuration

Table 1. Pin assignment

Pin Number	Name	Pin Number	Name	Pin Number	Name	Pin Number	Name	Pin Number	Name
1	PLLOUT	41	VCC	81	HDATA28	121	CMDATA0	161	GND
2	GND	42	GND	82	HDATA29	122	CMDATA1	162	CMDATA27
3	VCC	43	HDATA0	83	VCC	123	CMDATA2	163	CMDATA28
4	CLK	44	HDATA1	84	GND	124	VCC	164	CMDATA29
5	RESET*	45	HDATA2	85	HDATA30	125	GND	165	CMDATA30
6	CLK10	46	HDATA3	86	HDATA31	126	CMDATA3	166	CMDATA31
7	HOSTBIGE	47	HDATA4	87	CPUR*	127	CMDATA4	167	GND
8	TCK	48	HDATA5	88	SES0*	128	CMDATA5	168	GND
9	TMS	49	HDATA6	89	SES1*	129	VCC	169	VCC_3VOLT
10	TDI	50	VCC	90	SES2*	130	GND	170	GND
11	TRST*	51	GND	91	SES3*	131	CMDATA6	171	GND
12	TDO	52	HDATA7	92	CAM	132	CMDATA7	172	VCC
13	VCC	53	HDATA8	93	COCI	133	CMDATA8	173	GND
14	GND	54	HDATA9	94	COCO	134	VCC	174	GND
15	HSEL*	55	HDATA10	95	CMCS0*	135	GND	175	NC
16	HRD*	56	HDATA11	96	CMCS1*	136	CMDATA9	176	LDI1
17	HWR*	57	VCC	97	VCC	137	CMDATA10	177	LSI1
18	HACK	58	GND	98	GND	138	CMDATA11	178	LDO1
19	HINTR*	59	HDATA12	99	CMRD*	139	CMDATA12	179	LSO1
20	VCC	60	HDATA13	100	CMWR*	140	CMDATA13	180	LDI2
21	GND	61	HDATA14	101	CMADR0	141	CMDATA14	181	LSI2
22	HADR0	62	HDATA15	102	CMADR1	142	VCC	182	NC
23	HADR1	63	HDATA16	103	CMADR2	143	GND	183	VCC
24	HADR2	64	HDATA17	104	CMADR3	144	CMDATA15	184	VCC
25	HADR3	65	VCC	105	CMADR4	145	CMDATA16	185	VCC
26	HADR4	66	GND	106	VCC	146	CMDATA17	186	LDO2
27	HADR5	67	HDATA18	107	GND	147	CMDATA18	187	LSO2
28	HADR6	68	HDATA19	108	CMADR5	148	CMDATA19	188	LDI3
29	HADR7	69	HDATA20	109	CMADR6	149	CMDATA20	189	LSI3
30	VCC	70	HDATA21	110	CMADR7	150	VCC	190	LDO3
31	GND	71	HDATA22	111	CMADR8	151	GND	191	LSO3
32	BOOTLINK	72	HDATA23	112	CMADR9	152	CMDATA21	192	TIME_CODE_SYNC
33	SMCSADR0	73	VCC	113	CMADR10	153	CMDATA22	193	GND
34	SMCSADR1	74	GND	114	CMADR11	154	CMDATA23	194	GND
35	SMCSADR2	75	HDATA24	115	VCC	155	VCC	195	VCC
36	SMCSADR3	76	HDATA25	116	GND	156	GND	196	GND
37	SMCSID0	77	HDATA26	117	CMADR12	157	CMDATA24		
38	SMCSID1	78	VCC	118	CMADR13	158	CMDATA25		
39	SMCSID2	79	GND	119	CMADR14	159	CMDATA26		
40	SMCSID3	80	HDATA27	120	CMADR15	160	VCC		

3. Pin Description

Table 2. Pin description

Signal Name ⁽¹⁾⁽³⁾	Type ⁽²⁾⁽⁴⁾	Function	5V ± 0.5V max. output current [mA]	3.3V ± 0.3V max. output current [mA]	load [pF]
HSEL*	I	Select host interface			
HRD*	I	host interface read strobe			
HWR*	I	host interface write strobe			
HADR(7:0)	I	AT7911E register address lines. These address lines will be used to access (address) the AT7911E registers.			
HDATA(31:0)	IO/Z	AT7911E data	3	1.5	50
HACK	O/Z	host acknowledge. The AT7911E deasserts this output to add waitstates to an AT7911E access. After AT7911E is ready this output will be asserted.	3	1.5	50
HINTR*	O/Z	host interrupt request line	3	1.5	50
SMCSADR(3:0)	I	Address. The binary value of these lines will be compared with the value of the ID lines.			
SMCSID(3:0)	I	ID lines: offers possibility to use sixteen AT7911E within one HSEL*			
HOSTBIGE	I	0: host I/F Little Endian 1: host I/F Big Endian			
BOOTLINK	I	0: control by host 1: control by link			
CMCS(1:0)*	O/Z	Communication memory select lines. These pins are asserted as chip selects for the corresponding banks of the communication memory.	6	3	25
CMRD*	O/Z	Communication memory read strobe. This pin is asserted when the AT7911E reads data from memory.	6	3	25
CMWR*	O/Z	Communication memory write strobe. This pin is asserted when the AT7911E writes to data memory.	6	3	25
CMADR(15:0)	O/Z	Communication memory address. The AT7911E outputs an address on these pins.	6	3	25
CMDATA(31:0)	IOZ	Communication memory data. The AT7911E inputs and outputs data from and to com. memory on these pins.	3	1.5	25
COCI	I	Communication interface 'occupied' input signal			
COCO	O	Communication interface 'occupied' output signal	3	1.5	50
CAM	I	Communication interface arbitration master input signal 1: master 0: slave			
CPUR*	O	CPU Reset Signal (can be used as user defined flag)	3	1.5	50
SES(3:0)*	O	Specific External Signals (can be used as user defined flags)	3	1.5	50
LDI1	I	Link Data Input channel 1			
LSI1	I	Link Strobe Input channel 1			
LDO1	O	Link Data Output channel 1	12	6	25

Signal Name ⁽¹⁾⁽³⁾	Type ⁽²⁾⁽⁴⁾	Function	5V ± 0.5V max. output current [mA]	3.3V ± 0.3V max. output current [mA]	load [pF]
LSO1	O	Link Strobe Output channel 1	12	6	25
LDI2	I	Link Data Input channel 2			
LSI2	I	Link Strobe Input channel 2			
LDO2	O	Link Data Output channel 2	12	6	25
LSO2	O	Link Strobe Output channel 2	12	6	25
LDI3	I	Link Data Input channel 3			
LSI3	I	Link Strobe Input channel 3			
LDO3	O	Link Data Output channel 3	12	6	25
LSO3	O	Link Strobe Output channel 3	12	6	25
TRST*	I	Test Reset. Resets the test state machine.			
TCK	I	Test Clock. Provides an asynchronous clock for JTAG boundary scan.			
TMS	I	Test Mode Select. Used to control the test state machine.			
TDI	I	Test Data Input. Provides serial data for the boundary scan logic.			
TDO	O	Test Data Output. Serial scan output of the boundary scan path.	3	1.5	50
RESET*	I	Reset. Sets the AT7911E to a known state. This input must be asserted (low) at power-up. The minimum width of RESET low is 5 cycles of CLK10 in parallel with CLK running.			
CLK	I	External clock input to AT7911E (max. 25 MHz). Must be derived from RAM access time.			
CLK10	I	External clock input to AT7911E DS-links (application specific, nominal 10 MHz). Used to generate to transmission speed and link disconnect timeout.			
TIME_CODE_SY NC	I	A falling edge on this signal sends (if enabled) the internal SpaceWire time code value over the links			
PLLOUT	O	Output of internal PLL. Used to connect a network of external RC devices. This is not a PLL clock output.			
VCC_3VOLT	I	PLL Control signal - Configure PLL for 3.3V or 5V operation VCC = 5 Volt: connect this signal with GND VCC = 3.3 Volt: connect this signal with VCC			
VCC		Power Supply			
GND		Ground			

- Notes:
1. Groups of pins represent busses where the highest number is the MSB.
 2. O = Output; I = Input; Z = High Impedance
 3. (*) = active low signal
 4. O/Z = if using a configuration with two AT7911Es these signals can directly be connected together (WIROR)

4. Interfaces

The AT7911E provides an interface between three SpaceWire links according to the SpaceWire standard ECSS-E-50-12A specification and a data processing node consisting of a Central Processing Unit and a communication data memory.

The AT7911E consists of the following blocks (See Figure 1):

- Three bidirectional SpaceWire channels
- Communication Memory Interface (COMI)
- Host Control Interface (HOI)
- Protocol Command Interface (PRCI)
- JTAG Test Interface

4.1 Three bidirectional SpaceWire channels,

Three bidirectional SpaceWire channels, all comprising the DS-link SpaceWire cell, receive and transmit sections (each including FIFOs) and a protocol processing unit (PPU). Each channel allows full duplex communication up to 200 Mbit/s in each direction. With protocol command execution a higher level of communication is supported. Link disconnect detection and parity check at character level are performed. A checksum generation for a check at packet level can be enabled.

The transmit rate is selectable between 1.25 and 200 Mbit/s. The startup transmit rate is 10 Mbit/s. For special applications the data transmit rate can be programmed to values even below 10 Mbit/s; the lowest possible SpaceWire transmit rate is 1.25 Mbit/s (the next values are 2.5 and 5 Mbit/s).

4.1.1 PPU Functional Description

Since the Protocol Processing Unit (PPU) determines a major part of the AT7911E functionality, the principal blocks of the PPU and their function are described here. The PPU unit functionality is provided for each SpaceWire channel of the AT7911E.

4.1.1.1 Protocol Execution Unit

This unit serves as the main controller of the PPU block. It receives the character from the SpaceWire cell and interprets (in protocol mode) the four header data characters received after an EOP control character. If the address field matches the link channel address and the command field contains a valid command then forwarding of data into the receive FIFO is enabled. If the command field contains a "simple control command" then the execution request is forwarded to the command execution unit.

The protocol execution unit also enables forwarding of header data characters to the acknowledge generator and provides an error signal in case of address mismatch, wrong commands or disabled safety critical "simple control commands".

The protocol execution unit is disabled in "transparent" or "wormhole routing" operation mode.

4.1.1.2 Receive, Transmit, Acknowledge

The transmit and receive FIFOs decouple the SpaceWire link related operations from the AT7911E related operations in all modes and such allows to keep the speed of the different units even when the source or sink of data is temporarily blocked.

In the protocol mode an additional FIFO (acknowledge FIFO) is used to decouple sending of acknowledges from receiving new data when the transmit path is currently occupied by a running packet transmission.

4.1.1.3 *Command Execution Unit*

This unit performs activating resp. deactivating of the CPU reset and the specific external signals and provides the capability to reset one or all links inside the AT7911E, all actions requested by the decoded commands from the protocol execution unit.

The unit contains a register controlling the enable/disable state of safety critical commands which is set into the 'enable' state upon command request and which is reset after a safety critical command has been executed.

The CPU reset and the specific external signals are forwarded to the Protocol Command Interface (PRCI).

4.2 **Communication Memory Interface (COMI)**

The COMI performs autonomous accesses to the communication memory of the module to store data received via the links or to read data to be transmitted via the links. The COMI consists of individual memory address generators for the receive and transmit direction of every SpaceWire link channel. The access to the memory is controlled via an arbitration unit providing a fair arbitration scheme. Two AT7911E can share one DPRAM without external arbitration logic.

The data bus width is scalable (8/16/32 bit) to allow flexible integration with any CPU type.

Operation in little or big endian mode is configurable through internal registers.

The COMI address bus is 16 bit wide allowing direct access of up to 64K words (32 bits) of the DPRAM. Two chip select signals are provided to allow splitting of the 64k address space in two memory banks.

4.3 **Host Control Interface (HOCI)**

The HOCI gives read and write access to the AT7911E configuration registers and to the SpaceWire channels for the controlling CPU. Viewed from the CPU, the interface behaves like a peripheral that generates acknowledges to synchronize the data transfers and which is located somewhere in the CPU's address space.

Packets can be transmitted or received directly via the HOCI. In this case the Communication Memory (DPRAM) is not strictly needed. However, in this case the packet size should be limited to avoid frequent CPU interaction.

The data bus width is scalable (8/16/32 bit) to allow flexible integration with any CPU type. The byte alignment can be configured for little or big endian mode through an external pin.

Additionally, the HOCI contains the interrupt signalling capability of the AT7911E by providing an interrupt output, the interrupt status register and interrupt mask register to the local CPU.

A special pin is provided to select between control of the AT7911E by HOCI or by link. If control by link is enabled, the host data bus functions as a 32-bit general purpose interface (GPIO).

4.4 **Protocol Command Interface (PRCI)**

The PRCI collects the decoded commands from all PPU's and forwards them to external circuitry via 5 special pins.

4.5 JTAG Test Interface

It represents the boundary scan testing provisions specified by IEEE Standard 1149.1 of the Joint Testing Action Group (JTAG). The AT7911E test access port and on-chip circuitry is fully compliant with the IEEE 1149.1 specification. The test access port enables boundary scan testing of circuitry connected to the AT7911E I/O pins.

5. Control Interface

The AT7911E can be configured/controled through two interfaces:

- HOCl interface
- Link control interface

5.1 HOCl interface

The HOst Control Interface is especialy designed for access to internal AT6911E registers by a local controller (μ Controller, FPGA etc.).

The detailed description of this operation mode can be found in the section 5.4 of the 'SMCS332SpW User Manual'.

5.2 Link control interface

Link control is the feature of the AT7911E that allows the control of the AT7911E not only via HOCl but via one of the three links. This allows to use the AT7911E in systems without a local controller. Since the HOCl is no longer used in this operation mode, it is instead available as a set of general purpose I/O (GPIO) lines.

The detailed description of this operation mode can be found in the section 5.4 of the 'SMCS332SpW User Manual'.

6. Operating Modes

According to the different protocol formats expected for the operation of the AT7911E, two major operation modes are implemented into the AT7911E. For each link channel the operation modes are chosen individually by setting the respective configuration registers via the HOCI or via the link.

6.1 Simple Interprocessor Communication (SIC) Protocol Mode

This mode executes the simple interprocessor communication protocol as described in the chapter 13 of the 'SMCS332SpW User Manual'.

The following capabilities of the protocol are implemented into the AT7911E:

- Interpretation of the first 4 data characters as the header bytes of the protocol
- Autonomous execution of the simple control commands as described in the above mentioned chapter
- Autonomous acknowledgement of received packets if configured

In transmit direction no interpretation of the data is performed. This means that for transmit packets, the four header bytes must be generated by the host CPU and must be available as the first data read from the communication memory. EOP control characters are automatically inserted by the AT7911E when one configured transfer from the communication memory has finished.

6.2 Transparent Mode (default after reset)

This mode allows complete transparent data transfer between two nodes without performing any interpretation of the databytes and without generating any acknowledges. It is completely up to the host CPU to interpret the received data and to generate acknowledges if required.

The AT7911E accepts EOP and EEP control tokens as packet delimiters and generates autonomously EOP or no EOP (as configured) marker after each end of a transmission packet.

The transparent mode includes as a special submode: Wormhole routing.

6.2.1 Wormhole routing

This mode allows hardware routing of packets by the AT7911E. It is a submode of the transparent mode. The AT7911E introduces a wormhole routing function similar to the routing implemented in the SpaceWire router. Each of the three links and the AT7911E itself can be assigned an eight bit address. When routing is enabled in the AT7911E, the first byte of a packet will be interpreted as the address destination byte, analysed and removed from the packet (header deletion). If this address matches one of the two other link addresses or the AT7911E address assigned previously, the packet will be automatically forwarded to this link or the FIFO of the AT7911E. If the header byte does not match a link address, the packet will be written to the internal FIFO as well and an error interrupt (maskable) will be raised.

7. Fault Tolerance

The SpaceWire standard specifies low level checks as link disconnect, credit value, sequence and parity at token level. The AT7911E provides, through the Protocol Processing Unit, features



to reset a link or all links inside the AT7911E, to reset the local CPU or to send special signals to the CPU commanded via the links.

Additionally it is possible to enable a checksum coder/decoder to have fault detection capabilities at packet level.

8. Typical Applications

The AT7911E can be used for single board systems where standardised high speed interfaces are needed. Even "non-intelligent" modules such as A/D-converter or sensor interfaces can be assembled with the AT7911E because of the "control by link" feature. The complete control of the AT7911E can be done via link from a central controller-node.

The AT7911E is a very high speed, scalable link-interface chip with fault tolerance features. The initial exploitation is for use in multi-processor systems where the standardization or the high speed of the links is an important issue and where reliability is a requirement. Further application examples are heterogeneous systems or modules without any communication features as special image compression chips, certain signal processors, application specific programmable logic or mass memory.

The Figure below shows the AT7911E (also called SMCS332SpW) embedded in a typical module environment:

Figure 8-1. Typical Application

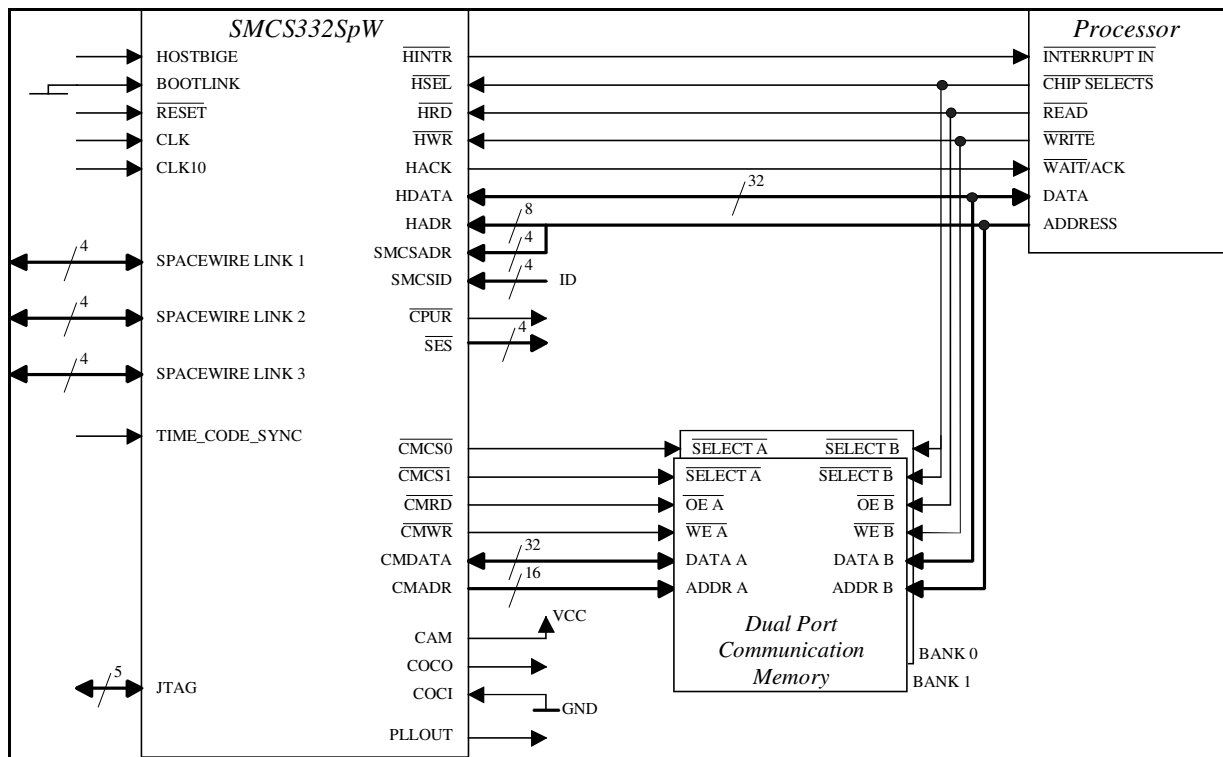

8.1 AT7911E connected with the TSS901E (or SMCS332)

The new ECSS-E-50-12A SpaceWire standard, used by the AT7911E and the IEEE-1355 standard used by the old TSS901E are compatible, however the TSS901E has a slightly different startup behavior, the TSS901E must be started first on a link connecting with the AT7911E.

8.2 AT7911E differences with the TSS901E (or SMCS332)

A few differences between the AT7911E and the TSS901E exist in the registers and in the pinout. These differences are detailed in the section 14 of the 'SMCS332SpW User Manual'.

8.3 Handling empty packets

An anomaly due to the SpaceWire codec implemented in the AT7911E affect the behavior of the AT7911E when receiving empty packets. The description of this anomaly and the possible workaround are given in the section 12 of the 'SMCS332SpW User Manual'.

9. PLL Filter

The AT7911E embeds a PLL to generate its internal clock reference. The PLLOUT pin of the PLL is the output of the AT7911E that allows connection of the external filter of the PLL. The following figure presents the connection of the PLL filter.

Figure 9-1. PLL filter

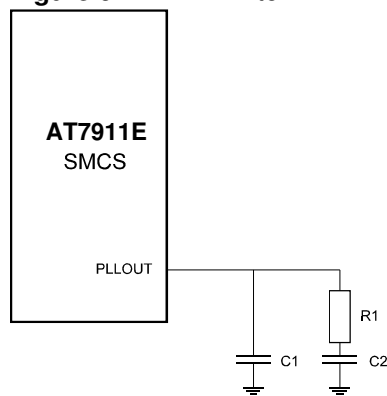

Table 9-1. PLL filter recommended components

VCC = +5V ± 0.5V		VCC = +3.3V ± 0.3V	
R1	1,8 kΩ ± 5%, ¼W	R1	2,0 kΩ ± 5%, ¼W
C1	33pF, ± 5%	C1	33pF, ± 5%
C2	820pF, ± 5%	C2	760pF, ± 5%

10. Power Supply

To achieve its fast cycle time, the AT7911E is designed with high speed drivers on output pins. Large peak currents may pass through a circuit board’s ground and power lines, especially when many output drivers are simultaneously charging or discharging their load capacitances. These transient currents can cause disturbances on the power and ground lines. To minimize these effects, the AT7911E provides separate supply pins for its internal logic and for its external drivers.

All GND pins should have a low impedance path to ground. A ground plane is required in AT7911E systems to reduce this impedance, minimizing noise.

The VCC pins should be bypassed to the ground plane using approximately 10 high-frequency capacitors (0.1 F ceramic). Keep each capacitor’s lead and trace length to the pins as short as possible. This low inductive path provides the AT7911E with the peak currents required when its output drivers switch. The capacitors’ ground leads should also be short and connect directly to the ground plane. This provides a low impedance return path for the load capacitance of the AT7911E output drivers.

The following pins must have a capacitor: 20, 78, 129, and 155. The remaining capacitors should be distributed equally around the AT7911E.

11. Electrical Characteristics

11.1 Absolute Maximum Ratings

Table 11-1. Absolute Maximum Ratings

Parameter	Symbol	Value	Unit
Supply Voltage	VCC	-0.5 to +7	V
I/O Voltage		-0.5 to VCC + 0.5	V
Operating Temperature Range (Ambient)	TA	-55 to +125	°C
Junction Temperature	TJ	TJ < TA +20	°C
Storage Temperature Range	Tstg	-65 to +150	°C
Thermal resistance: junction to case	RThJC	4	°C/W

Stresses above those listed may cause permanent damage to the device.

11.2 DC Electrical Characteristics

The AT7911E can work with $VCC = + 5 V \pm 0.5 V$ and $VCC = + 3.3V \pm 0.3V$. Although specified for TTL outputs, all AT7911E outputs are CMOS compatible and will drive to VCC and GND assuming no DC loads.

Table 11-2. 5V operating range DC Characteristics.

Parameter	Symbol	Min.	Max.	Unit	Conditions
Operating Voltage	VCC	4.5	5.5	V	
Input HIGH Voltage	VIH	2.2		V	
Input LOW Voltage	VIL		0.8	V	
Output HIGH Voltage	VOH	2.4		V	IOL = 3, 6, 12mA / VCC = VCC(min)
Output LOW Voltage	VOL		0.4	V	IOH = 3, 6, 12mA / VCC = VCC(min)
Output Short circuit current	IOS		90 ⁽¹⁾ 180 ⁽²⁾ 270 ⁽³⁾	mA mA mA	VOUT = VCC VOUT = GND

- Notes:
1. Applicable for HDATA[31:0], HACK, HINTR*, CMDATA[31:0], COCI, CPUR*, SES[3:0]* and TDO pins
 2. Applicable for CMCS[1:0]*, CMRD*, CMWR* and CMADR[31:0] pins
 3. Applicable for LDO1, LSO1, LDO2, LSO2, LDO3 and LSO3 pins

Table 11-3. 3.3V operating range DC Characteristics.

Parameter	Symbol	Min.	Max.	Unit	Conditions
Operating Voltage	VCC	3.0	3.6	V	
Input HIGH Voltage	VIH	2.0		V	
Input LOW Voltage	VIL		0.8	V	
Output HIGH Voltage	VOH	2.4		V	IOL = 1.5, 3, 6mA / VCC = VCC(min)
Output LOW Voltage	VOL		0.4	V	IOH = 1, 2, 4mA / VCC = VCC(min)
Output Short circuit current	IOS		50 ⁽¹⁾ 100 ⁽²⁾ 155 ⁽³⁾	mA mA mA	VOUT = VCC VOUT = GND

- Notes:
1. Applicable for HDATA[31:0], HACK, HINTR*, CMDATA[31:0], COCI, CPUR*, SES[3:0]* and TDO pins
 2. Applicable for CMCS[1:0]*, CMRD*, CMWR* and CMADR[31:0] pins
 3. Applicable for LDO1, LSO1, LDO2, LSO2, LDO3 and LSO3 pins

11.3 Power consumption

Max. power consumption figures at $V_{cc} = 5.5V$; $-55^{\circ}C$; $CLK = 25\text{ MHz}$ are presented in the following table.

Table 11-4. 5V Power Consumption

Operation Mode	Power consumption [mA]
not clocked	8
AT7911E in RESET	75
AT7911E in IDLE ⁽¹⁾	115
Maximum	310

1. IDLE means $clk = 25\text{ MHz}$, all three links started and running at 10Mbit/s , no activity on HOCl and COMI

Max. power consumption figures at $V_{cc} = 3.6V$; $-55^{\circ}C$; $CLK = 15\text{ MHz}$ are presented in the following table.

Table 11-5. 3.3V Power Consumption

Operation Mode	Power consumption [mA]
not clocked	4
AT7911E in RESET	24
AT7911E in IDLE ⁽¹⁾	38
Maximum	100

1. IDLE means $clk = 15\text{ MHz}$, all three links started and running at 10Mbit/s , no activity on HOCl and COMI

11.4 AC Electrical Characteristics

The following table gives the worst case timings measured by Atmel on the 4.5V to 5.5V operating range

Table 11-6. 5V operating range timings.

Parameter	Symbol	Min.	Max.	Unit
Propagation delay CLK Low to HACK High	Tp1		29	ns
Propagation delay CLK High to CMCS0* Low	Tp2		18	ns
Propagation delay CLK High to CMADR0 High	Tp3		17	ns
Propagation delay CLK10 High to LDO1 High	Tp4		30	ns
Propagation delay CLK10 High to LDO2 High	Tp5		32	ns
Propagation delay CLK10 High to LDO3 High	Tp6		36	ns

The following table gives the worst case timings measured by Atmel on the 3.0V to 3.6V operating range

Table 11-7. 3.3V operating range timings

Parameter	Symbol	Min.	Max.	Unit
Propagation delay CLK Low to HACK High	Tp1		47	ns
Propagation delay CLK High to CMCS0* Low	Tp2		30	ns
Propagation delay CLK High to CMADR0 High	Tp3		28	ns
Propagation delay CLK10 High to LDO1 High	Tp4		51	ns
Propagation delay CLK10 High to LDO2 High	Tp5		54	ns
Propagation delay CLK10 High to LDO3 High	Tp6		61	ns

For guaranteed timings on the two operating voltage ranges, refer to the section 9 of the 'SMCS332SpW User Manual'

12. Ordering Information

Part-number	Temperature Range	Package	Quality Flow
AT7911EFA-E	25°C	MQFPL196	Engineering sample
5962-08A0101QXC	-55°C to +125°C	MQFPL196	Mil Level B (*)
5962-08A0101VXC	-55°C to +125°C	MQFPL196	Space Level B (*)

(*) according to Atmel Quality flow document 4288, see Atmel web site.

13. Package Drawings

196 pins Ceramic Quad Flat Pack (MQFP_L 196)

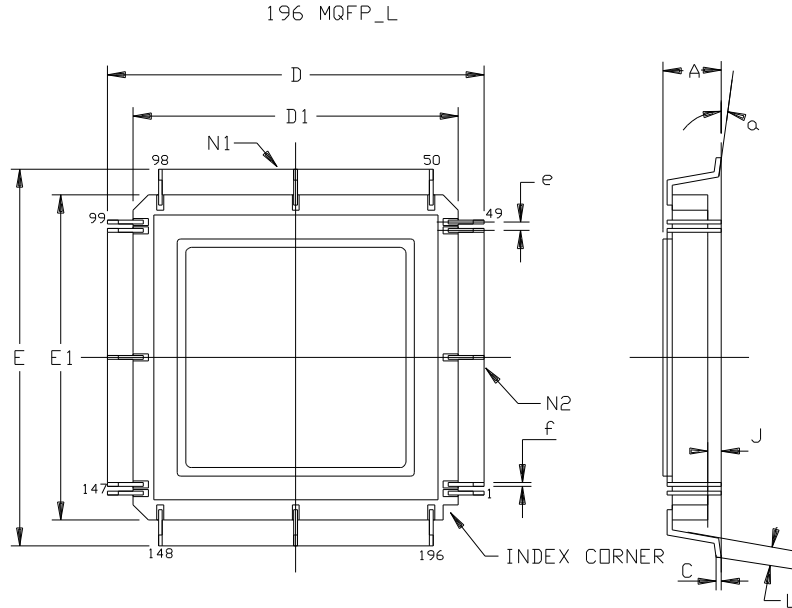

	Min	Max	Min	Max
A	2.36	2.97	.093	.117
C	0.20 TYP		.008 TYP	
D	38.74	39.75	1.525	1.565
D1	34.03	34.54	1.340	1.360
E	38.74	39.75	1.525	1.565
E1	34.03	34.54	1.340	1.360
e	0.635 BSC		.025 BSC	
f	0.203 REF		.008 REF	
J	0.15	0.30	.006	.012
L	0.61	1.01	.024	.040
N1	49		49	
N2	49		49	
$\alpha = 4^\circ \pm 4^\circ$				

Lid connected to Ground

14. Document Revision History

14.1 7737B

1. Ordering information updated.



Headquarters

Atmel Corporation
2325 Orchard Parkway
San Jose, CA 95131
USA
Tel: 1(408) 441-0311
Fax: 1(408) 487-2600

International

Atmel Asia
Room 1219
Chinachem Golden Plaza
77 Mody Road Tsimshatsui
East Kowloon
Hong Kong
Tel: (852) 2721-9778
Fax: (852) 2722-1369

Atmel Europe
Le Krebs
8, Rue Jean-Pierre Timbaud
BP 309
78054 Saint-Quentin-en-
Yvelines Cedex
France
Tel: (33) 1-30-60-70-00
Fax: (33) 1-30-60-71-11

Atmel Japan
9F, Tonetsu Shinkawa Bldg.
1-24-8 Shinkawa
Chuo-ku, Tokyo 104-0033
Japan
Tel: (81) 3-3523-3551
Fax: (81) 3-3523-7581

Product Contact

Web Site
www.atmel.com

Technical Support
aerospace@nto.atmel.com

Sales Contact
www.atmel.com/contacts

Literature Requests
www.atmel.com/literature

Disclaimer: The information in this document is provided in connection with Atmel products. No license, express or implied, by estoppel or otherwise, to any intellectual property right is granted by this document or in connection with the sale of Atmel products. **EXCEPT AS SET FORTH IN ATMEL'S TERMS AND CONDITIONS OF SALE LOCATED ON ATMEL'S WEB SITE, ATMEL ASSUMES NO LIABILITY WHATSOEVER AND DISCLAIMS ANY EXPRESS, IMPLIED OR STATUTORY WARRANTY RELATING TO ITS PRODUCTS INCLUDING, BUT NOT LIMITED TO, THE IMPLIED WARRANTY OF MERCHANTABILITY, FITNESS FOR A PARTICULAR PURPOSE, OR NON-INFRINGEMENT. IN NO EVENT SHALL ATMEL BE LIABLE FOR ANY DIRECT, INDIRECT, CONSEQUENTIAL, PUNITIVE, SPECIAL OR INCIDENTAL DAMAGES (INCLUDING, WITHOUT LIMITATION, DAMAGES FOR LOSS OF PROFITS, BUSINESS INTERRUPTION, OR LOSS OF INFORMATION) ARISING OUT OF THE USE OR INABILITY TO USE THIS DOCUMENT, EVEN IF ATMEL HAS BEEN ADVISED OF THE POSSIBILITY OF SUCH DAMAGES.** Atmel makes no representations or warranties with respect to the accuracy or completeness of the contents of this document and reserves the right to make changes to specifications and product descriptions at any time without notice. Atmel does not make any commitment to update the information contained herein. Unless specifically provided otherwise, Atmel products are not suitable for, and shall not be used in, automotive applications. Atmel's products are not intended, authorized, or warranted for use as components in applications intended to support or sustain life.

© 2008 Atmel Corporation. All rights reserved. Atmel®, logo and combinations thereof, and others are registered trademarks or trademarks of Atmel Corporation or its subsidiaries. Other terms and product names may be trademarks of others.