

Features

- Number of Keys:
 - One
 - Configurable as either a single key or a proximity sensor
- Technology:
 - Patented spread-spectrum charge-transfer (direct mode)
- Key outline sizes:
 - 6 mm x 6 mm or larger (panel thickness dependent); widely different sizes and shapes possible
- Electrode design:
 - Solid or ring electrode shapes
- PCB Layers required:
 - One
- Electrode materials:
 - Etched copper, silver, carbon, Indium Tin Oxide (ITO)
- Electrode substrates:
 - PCB, FPCB, plastic films, glass
- Panel materials:
 - Plastic, glass, composites, painted surfaces (low particle density metallic paints possible)
- Panel thickness:
 - Up to 12 mm glass, 6 mm plastic (electrode size and Cs dependent)
- Key sensitivity:
 - Settable via capacitor (Cs)
- Interface:
 - Digital output, active high
- Moisture tolerance:
 - Good
- Power:
 - 1.8V – 5.5V; 17 μ A at 1.8V typical
- Package:
 - 6-pin SOT23-6 RoHS compliant
 - 8-pin UDFN/USON RoHS compliant
- Signal processing:
 - Self-calibration, auto drift compensation, noise filtering
- Applications:
 - Control panels, consumer appliances, proximity sensor applications, toys, lighting controls, mechanical switch or button,
- Patents:
 - QTouch[®] (patented charge-transfer method)
 - HeartBeat[™] (monitors health of device)



One-channel Touch Sensor IC

AT42QT1010



1. Pinout and Schematic

1.1 Pinout Configurations

1.1.1 6-pin SOT23-6

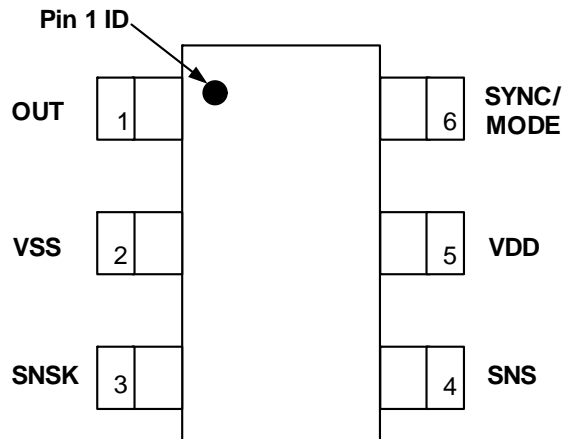

1.1.2 8-pin UDFN/USON

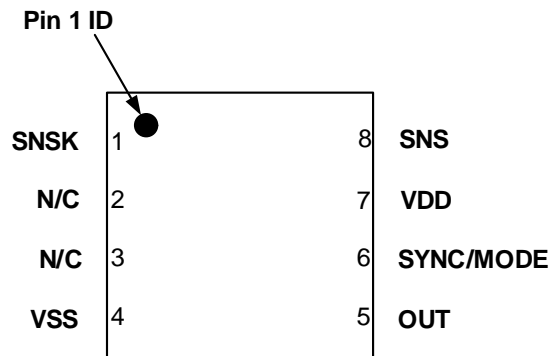

1.3 Schematics

1.3.1 6-pin SOT23-6

Figure 1-1. Basic Circuit Configuration

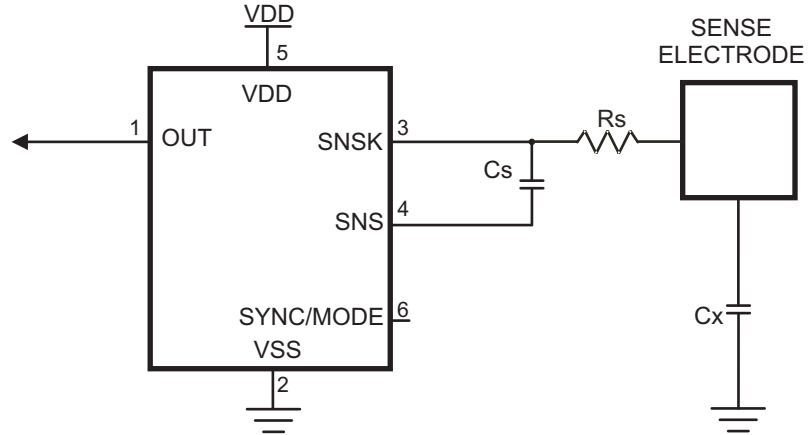

Note: A bypass capacitor should be tightly wired between Vdd and Vss and kept close to pin 5.

1.3.2 8-pin UDFN/USON

Figure 1-2. Basic Circuit Configuration

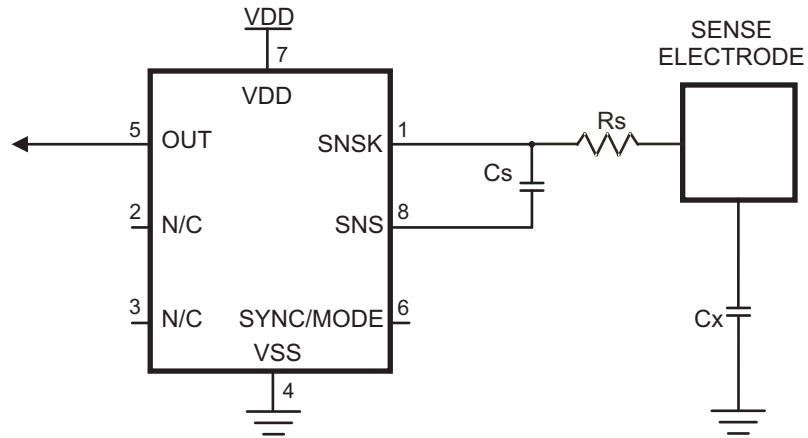

Note: A bypass capacitor should be tightly wired between Vdd and Vss and kept close to pin 7.

2. Overview of the AT42QT1010

2.1 Introduction

The AT42QT1010 (QT1010) is a digital burst mode charge-transfer (QT™) sensor that is capable of detecting near-proximity or touch, making it ideal for implementing touch controls.

With the proper electrode and circuit design, the self-contained digital IC will project a touch or proximity field to several centimeters through any dielectric like glass, plastic, stone, ceramic, and even most kinds of wood. It can also turn small metal-bearing objects into intrinsic sensors, making them responsive to proximity or touch. This capability, coupled with its ability to self-calibrate, can lead to entirely new product concepts.

The QT1010 is designed specifically for human interfaces, like control panels, appliances, toys, lighting controls, or anywhere a mechanical switch or button may be found. It includes all hardware and signal processing functions necessary to provide stable sensing under a wide variety of changing conditions. Only a single low-cost capacitor is required for operation.

2.2 Basic Operation

[Figure 1-1 on page 4](#) and [Figure 1-1 on page 4](#) show basic circuits.

The QT1010 employs bursts of charge-transfer cycles to acquire its signal. Burst mode permits power consumption in the microamp range, dramatically reduces RF emissions, lowers susceptibility to EMI, and yet permits excellent response time. Internally the signals are digitally processed to reject impulse noise, using a “consensus” filter which requires four consecutive confirmations of a detection before the output is activated.

The QT switches and charge measurement hardware functions are all internal to the QT1010.

2.3 Electrode Drive

For optimum noise immunity, the electrode should only be connected to SNSK.

In all cases the rule $C_s \gg C_x$ must be observed for proper operation; a typical load capacitance (C_x) ranges from 5-20 pF while C_s is usually about 2-50 nF.

Increasing amounts of C_x destroy gain, therefore it is important to limit the amount of stray capacitance on both SNS terminals. This can be done, for example, by minimizing trace lengths and widths and keeping these traces away from power or ground traces or copper pours.

The traces and any components associated with SNS and SNSK will become touch sensitive and should be treated with caution to limit the touch area to the desired location.

A series resistor, R_s , should be placed in line with SNSK to the electrode to suppress ESD and EMC effects.

2.4 Sensitivity

2.4.1 Introduction

The sensitivity on the QT1010 is a function of things like the value of C_s , electrode size and capacitance, electrode shape and orientation, the composition and aspect of the object to be sensed, the thickness and composition of any overlaying panel material, and the degree of ground coupling of both sensor and object.

2.4.2 Increasing Sensitivity

In some cases it may be desirable to increase sensitivity; for example, when using the sensor with very thick panels having a low dielectric constant, or when the device is used as a proximity sensor. Sensitivity can often be increased by using a larger electrode or reducing panel thickness. Increasing electrode size can have diminishing returns, as high values of C_x will reduce sensor gain.

The value of C_s also has a dramatic effect on sensitivity, and this can be increased in value with the trade-off of slower response time and more power. Increasing the electrode's surface area will not substantially increase touch sensitivity if its diameter is already much larger in surface area than the object being detected. Panel material can also be changed to one having a higher dielectric constant, which will better help to propagate the field.

In the case of proximity detection, usually the object being detected is on an approaching hand, so a larger surface area can be effective.

Ground planes around and under the electrode and its SNSK trace will cause high C_x loading and destroy gain. The possible signal-to-noise ratio benefits of ground area are more than negated by the decreased gain from the circuit, and so ground areas around electrodes are discouraged. Metal areas near the electrode will reduce the field strength and increase C_x loading and should be avoided, if possible. Keep ground away from the electrodes and traces.

2.4.3 Decreasing Sensitivity

In some cases the QT1010 may be too sensitive. In this case gain can be easily lowered further by decreasing C_s .

2.4.4 Proximity Sensing

By increasing the sensitivity, the QT1010 can be used as a very effective proximity sensor, allowing the presence of a nearby object (typically a hand) to be detected.

In this scenario, as the object being sensed is typically a hand, very large electrode sizes can be used, which is extremely effective in increasing the sensitivity of the detector. In this case, the value of C_s will also need to be increased to ensure improved sensitivity, as mentioned in [Section 2.4.2](#). Note that, although this affects the responsiveness of the sensor, it is less of an issue in proximity sensing applications; in such applications it is necessary to detect simply the presence of a large object, rather than a small, precise touch.

3. Operation Specifics

3.1 Run Modes

3.1.1 Introduction

The QT1010 has three running modes which depend on the state of the SYNC pin (high or low).

3.1.2 Fast Mode

The QT1010 runs in Fast mode if the SYNC pin is permanently high. In this mode the QT1010 runs at maximum speed at the expense of increased current consumption. Fast mode is useful when speed of response is the prime design requirement. The delay between bursts in Fast mode is approximately 1 ms, as shown in [Figure 3-1](#).

Figure 3-1. Fast Mode Bursts (SYNC Held High)

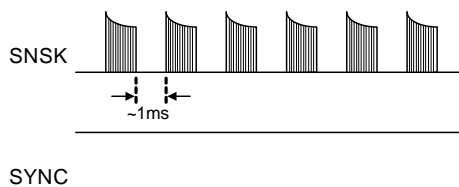

3.1.3 Low Power Mode

The QT1010 runs in Low Power (LP) mode if the SYNC pin is held low. In this mode it sleeps for approximately 80 ms at the end of each burst, saving power but slowing response. On detecting a possible key touch, it temporarily switches to Fast mode until either the key touch is confirmed or found to be spurious (via the detect integration process). It then returns to LP mode after the key touch is resolved, as shown in [Figure 3-2 on page 7](#).

Figure 3-2. Low Power Mode (SYNC Held Low)

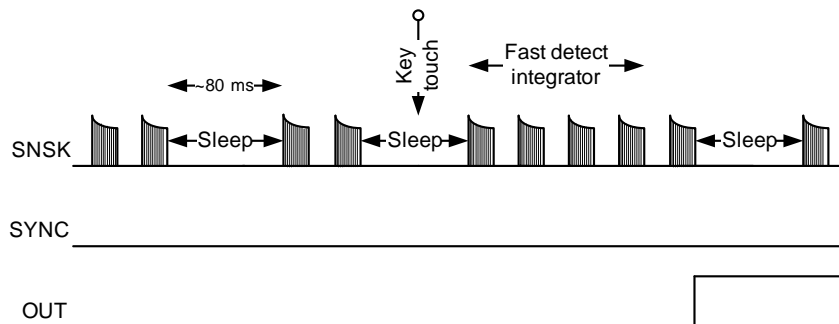

3.1.4 SYNC Mode

It is possible to synchronize the device to an external clock source by placing an appropriate waveform on the SYNC pin. SYNC mode can synchronize multiple QT1010 devices to each other to prevent cross-interference, or it can be used to enhance noise immunity from low frequency sources such as 50Hz or 60Hz mains signals.

The SYNC pin is sampled at the end of each burst. If the device is in Fast mode and the SYNC pin is sampled high, then the device continues to operate in Fast mode (Figure 3-1 on page 7). If SYNC is sampled low, then the device goes to sleep. From then on, it will operate in SYNC mode (Figure 3-2). Therefore, to guarantee entry into SYNC mode the low period of the SYNC signal should be longer than the burst length (Figure 3-3 on page 8).

Figure 3-3. SYNC Mode (Triggered by SYNC Edges)

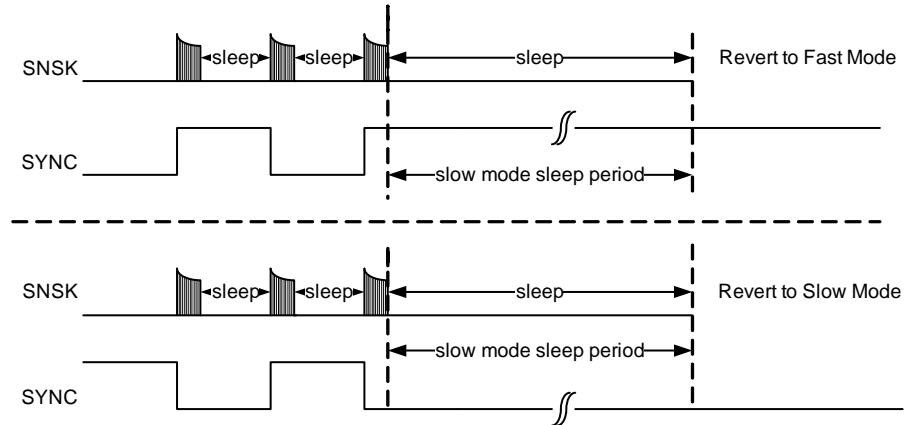

However, once SYNC mode has been entered, if the SYNC signal consists of a series of short pulses ($>10 \mu\text{s}$) then a burst will only occur on the falling edge of each pulse (Figure 3-4 on page 8) instead of on each change of SYNC signal, as normal (Figure 3-3).

In SYNC mode, the device will sleep after each measurement burst (just as in LP mode) but will be awakened by a change in the SYNC signal in either direction, resulting in a new measurement burst. If SYNC remains unchanged for a period longer than the LP mode sleep period (about 80 ms), the device will resume operation in either Fast or LP mode depending on the level of the SYNC pin (Figure 3-3).

There is no detect integrator (DI) in SYNC mode (each touch is a detection) but the Max On-duration will depend on the time between SYNC pulses; see Section 3.3 and Section 3.4. Recalibration timeout is a fixed number of measurements so will vary with the SYNC period.

Figure 3-4. SYNC Mode (Short Pulses)

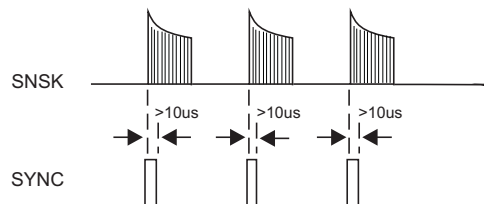

3.2 Threshold

The internal signal threshold level is fixed at 10 counts of change with respect to the internal reference level, which in turn adjusts itself slowly in accordance with the drift compensation mechanism.

The QT1010 employs a hysteresis dropout of two counts of the delta between the reference and threshold levels.

3.3 Max On-duration

If an object or material obstructs the sense pad the signal may rise enough to create a detection, preventing further operation. To prevent this, the sensor includes a timer which monitors detections. If a detection exceeds the timer setting the sensor performs a full recalibration. This is known as the Max On-duration feature and is set to ~60s (at 3V in LP mode). This will vary slightly with Cs and if SYNC mode is used. As the internal timebase for Max On-duration is determined by the burst rate, the use of SYNC can cause dramatic changes in this parameter depending on the SYNC pulse spacing. For example, at 60Hz SYNC mode the Max On-duration will be ~6s at 3V.

3.4 Detect Integrator

It is desirable to suppress detections generated by electrical noise or from quick brushes with an object. To accomplish this, the QT1010 incorporates a detect integration (DI) counter that increments with each detection until a limit is reached, after which the output is activated. If no detection is sensed prior to the final count, the counter is reset immediately to zero. In the QT1010, the required count is four. In LP mode the device will switch to Fast mode temporarily in order to resolve the detection more quickly; after a touch is either confirmed or denied the device will revert back to normal LP mode operation automatically.

The DI can also be viewed as a “consensus filter” that requires four successive detections to create an output.

3.5 Forced Sensor Recalibration

The QT1010 has no recalibration pin; a forced recalibration is accomplished when the device is powered up or after the recalibration timeout. However, supply drain is low so it is a simple matter to treat the entire IC as a controllable load; driving the QT1010's Vdd pin directly from another logic gate or a microcontroller port will serve as both power and “forced recalibration”. The source resistance of most CMOS gates and microcontrollers is low enough to provide direct power without problem.

3.6 Drift Compensation

Signal drift can occur because of changes in Cx and Cs over time. It is crucial that drift be compensated for, otherwise false detections, nondetections, and sensitivity shifts will follow.

Drift compensation ([Figure 3-5](#)) is performed by making the reference level track the raw signal at a slow rate, but only while there is no detection in effect. The rate of adjustment must be performed slowly, otherwise legitimate detections could be ignored. The QT1010 drift compensates using a slew-rate limited change to the reference level; the threshold and hysteresis values are slaved to this reference.

Once an object is sensed, the drift compensation mechanism ceases since the signal is legitimately high, and therefore should not cause the reference level to change.

Figure 3-5. Drift Compensation

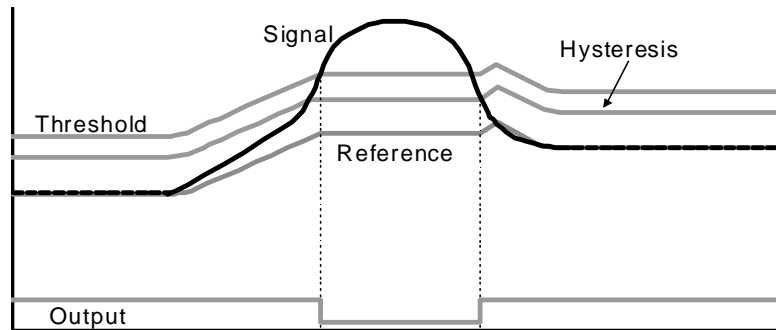

The QT1010's drift compensation is asymmetric; the reference level drift-compensates in one direction faster than it does in the other. Specifically, it compensates faster for decreasing signals than for increasing signals. Increasing signals should not be compensated for quickly, since an approaching finger could be compensated for partially or entirely before even approaching the sense electrode. However, an obstruction over the sense pad, for which the sensor has already made full allowance, could suddenly be removed leaving the sensor with an artificially elevated reference level and thus become insensitive to touch. In this latter case, the sensor will compensate for the object's removal very quickly, usually in only a few seconds.

With large values of C_s and small values of C_x , drift compensation will appear to operate more slowly than with the converse. Note that the positive and negative drift compensation rates are different.

3.7 Response Time

The QT1010's response time is highly dependent on run mode and burst length, which in turn is dependent on C_s and C_x . With increasing C_s , response time slows, while increasing levels of C_x reduce response time. The response time will also be a lot slower in LP or SYNC mode due to a longer time between burst measurements.

3.8 Spread Spectrum

The QT1010 modulates its internal oscillator by ± 7.5 percent during the measurement burst. This spreads the generated noise over a wider band, reducing emission levels. This also reduces susceptibility since there is no longer a single fundamental burst frequency.

3.9 Output Features

3.9.1 Output

The output of the QT1010 is active-high upon detection. The output will remain active-high for the duration of the detection, or until the Max On-duration expires, whichever occurs first. If a Max On-duration timeout occurs first, the sensor performs a full recalibration and the output becomes inactive (low) until the next detection.

3.9.2 HeartBeat™ Output

The QT1010 output has a HeartBeat “health” indicator superimposed on it in all modes. This operates by taking the output pin into a three-state mode for $15 \mu s$, once before every QT burst. This output state can be used to determine that the sensor is operating properly, using one of several simple methods, or it can be ignored.

The HeartBeat indicator can be sampled by using a pull-up resistor on the OUT pin (Figure 3-6), and feeding the resulting positive-going pulse into a counter, flip flop, one-shot, or other circuit. The pulses will only be visible when the chip is not detecting a touch.

Figure 3-6. Obtaining HeartBeat Pulses with a Pull-up Resistor (SOT23-6)

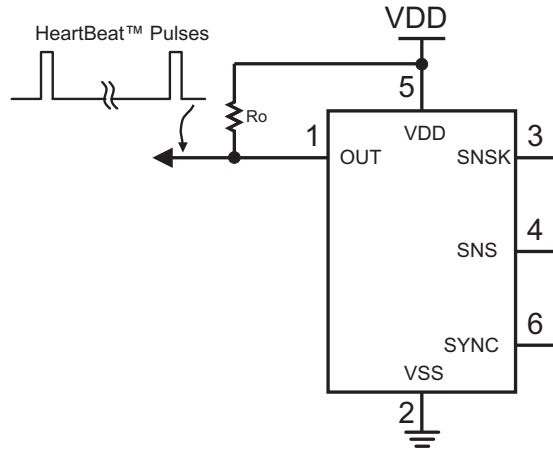

If the sensor is wired to a microcontroller as shown in Figure 3-7 on page 11, the microcontroller can reconfigure the load resistor to either Vss or Vdd depending on the output state of the QT1010, so that the pulses are evident in either state.

Figure 3-7. Using a Microcontroller to Obtain HeartBeat Pulses in Either Output State (SOT23-6)

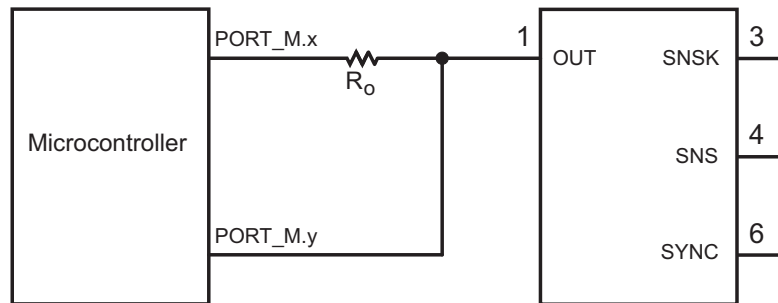

Electromechanical devices like relays will usually ignore the short HeartBeat pulse. The pulse also has too low a duty cycle to visibly affect LEDs. It can be filtered completely if desired, by adding an RC filter to the output, or if interfacing directly and only to a high-impedance CMOS input, by doing nothing or at most adding a small noncritical capacitor from OUT to Vss.

3.9.3 Output Drive

The OUT pin is active high and can sink or source up to 2 mA. When a large value of Cs (>20 nF) is used the OUT current should be limited to <1 mA to prevent gain-shifting side effects, which happen when the load current creates voltage drops on the die and bonding wires; these small shifts can materially influence the signal level to cause detection instability.

4. Circuit Guidelines

4.1 More Information

Refer to Application Note QTAN0002, *Secrets of a Successful QTouch® Design* and the *Touch Sensors Design Guide* (both downloadable from the Atmel® website), for more information on construction and design methods.

4.2 Sample Capacitor

Cs is the charge sensing sample capacitor. The required Cs value depends on the thickness of the panel and its dielectric constant. Thicker panels require larger values of Cs. Typical values are 2 nF to 50 nF depending on the sensitivity required; larger values of Cs demand higher stability and better dielectric to ensure reliable sensing.

The Cs capacitor should be a stable type, such as X7R ceramic or PPS film. For more consistent sensing from unit to unit, 5 percent tolerance capacitors are recommended. X7R ceramic types can be obtained in 5 percent tolerance at little or no extra cost. In applications where high sensitivity (long burst length) is required the use of PPS capacitors is recommended.

For battery powered operation a higher value sample capacitor is recommended (typical value 8.2 nF).

4.3 UDFN/USON Package Restrictions

The central pad on the underside of the UDFN/USON chip is connected to ground. Do not run any tracks underneath the body of the chip, only ground.

4.4 Power Supply and PCB Layout

See [Section 5.2 on page 14](#) for the power supply range. At 3V current drain averages less than 500 μ A in Fast mode.

If the power supply is shared with another electronic system, care should be taken to ensure that the supply is free of digital spikes, sags, and surges which can adversely affect the QT1010. The QT1010 will track slow changes in Vdd, but it can be badly affected by rapid voltage fluctuations. It is highly recommended that a separate voltage regulator be used just for the QT1010 to isolate it from power supply shifts caused by other components.

If desired, the supply can be regulated using a Low Dropout (LDO) regulator, although such regulators often have poor transient line and load stability. See Application Note QTAN0002, *Secrets of a Successful QTouch™ Design* for further information.

Parts placement: The chip should be placed to minimize the SNSK trace length to reduce low frequency pickup, and to reduce stray Cx which degrades gain. The Cs and Rs resistors (see [Figure 1-1 on page 4](#)) should be placed as close to the body of the chip as possible so that the trace between Rs and the SNSK pin is very short, thereby reducing the antenna-like ability of this trace to pick up high frequency signals and feed them directly into the chip. A ground plane can be used under the chip and the associated discrete components, but the trace from the Rs resistor and the electrode should not run near ground, to reduce loading.

For best EMC performance the circuit should be made entirely with SMT components.

Electrode trace routing: Keep the electrode trace (and the electrode itself) away from other signal, power, and ground traces including over or next to ground planes. Adjacent switching signals can induce noise onto the sensing signal; any adjacent trace or ground plane next to, or under, the electrode trace will cause an increase in Cx load and desensitize the device.

Important Note: for proper operation a 100 nF (0.1 μ F) ceramic bypass capacitor must be used directly between Vdd and Vss, to prevent latch-up if there are substantial Vdd transients; for example, during an ESD event. The bypass capacitor should be placed very close to the Vss and Vdd pins.

4.5 Power On

On initial power up, the QT1010 requires approximately 100 ms to power on to allow power supplies to stabilize. During this time the OUT pin state is not valid and should be ignored.

5. Specifications

5.1 Absolute Maximum Specifications

Operating temperature	-40°C to +85°C
Storage temperature	-55°C to +125°C
V _{DD}	0 to +6.5V
Max continuous pin current, any control or drive pin	±20 mA
Short circuit duration to V _{SS} , any pin	Infinite
Short circuit duration to V _{DD} , any pin	Infinite
Voltage forced onto any pin	-0.6V to (V _{DD} + 0.6) Volts
 CAUTION: Stresses beyond those listed under <i>Absolute Maximum Specifications</i> may cause permanent damage to the device. This is a stress rating only and functional operation of the device at these or other conditions beyond those indicated in the operational sections of this specification is not implied. Exposure to absolute maximum specification conditions for extended periods may affect device reliability	

5.2 Recommended Operating Conditions

V _{DD}	+1.8 to 5.5V
Short-term supply ripple + noise	±20 mV
Long-term supply stability	±100 mV
C _s value	2 to 50 nF
C _x value	5 to 50 pF

5.3 AC Specifications

V_{DD} = 3.0V, C_s = 4.7 nF, C_x = 5 pF, T_a = recommended range, unless otherwise noted

Parameter	Description	Min	Typ	Max	Units	Notes
T _{RC}	Recalibration time		200		ms	C _s , C _x dependent
T _{PC}	Charge duration		3.05		µs	±7.5% spread spectrum variation
T _{PT}	Transfer duration		9.0		µs	±7.5% spread spectrum variation
T _{G1}	Time between end of burst and start of the next (Fast mode)		1.2		ms	
T _{G2}	Time between end of burst and start of the next (LP mode)		80		ms	Increases with decreasing V _{DD} See Figure 5-1 on page 15
T _{BL}	Burst length		2.45		ms	V _{DD} , C _s and C _x dependent. See Section 4.2 for capacitor selection.
T _R	Response time			100	ms	
T _{HB}	HeartBeat pulse width		15		µs	

Figure 5-1. T_{G2} – Time Between Bursts (LP Mode)

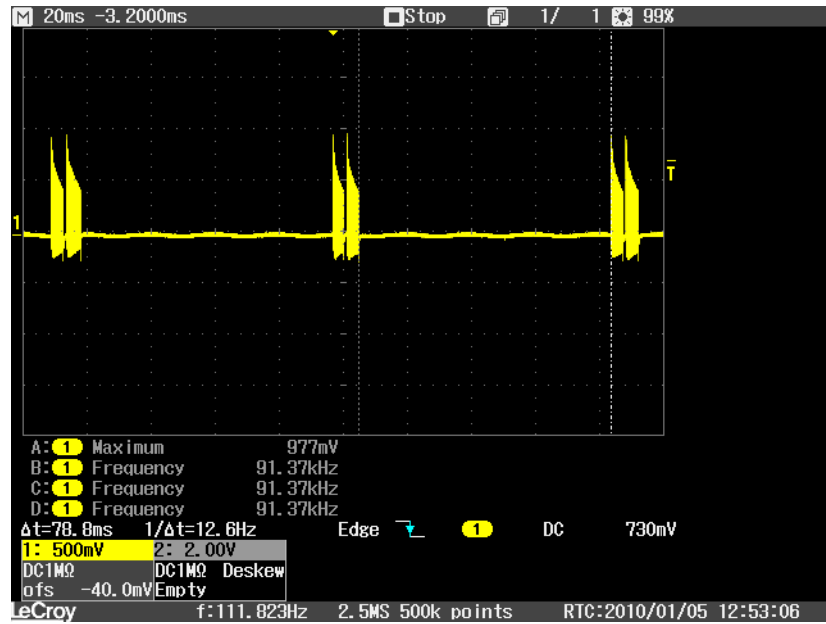
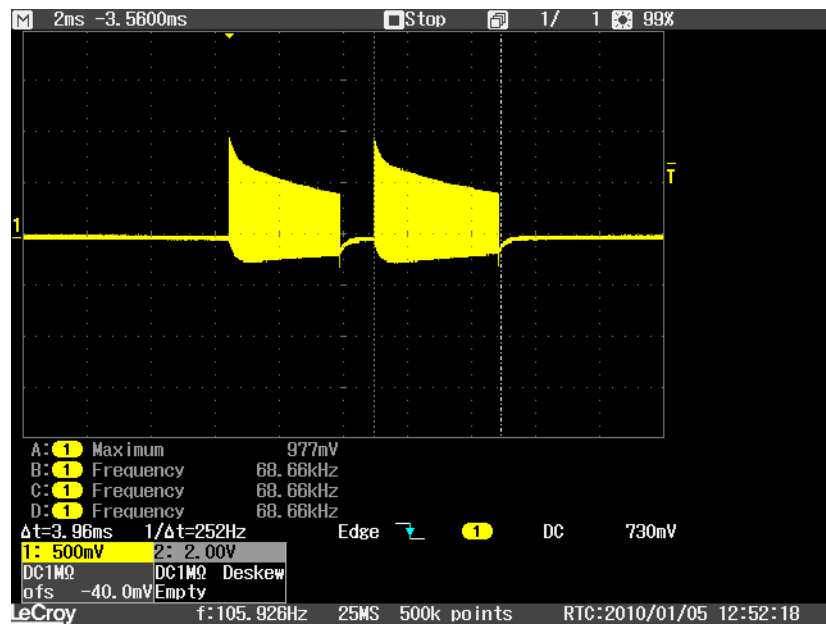

Figure 5-2. T_{BL} – Burst Length



5.4 Signal Processing

V_{DD} = 3.0V, C_s = 4.7 nF, C_x = 5 pF, T_a = recommended range, unless otherwise noted

Description	Min	Typ	Max	Units	Notes
Threshold differential		10		counts	
Hysteresis		2		counts	
Consensus filter length		4		samples	
Max on-duration		60		seconds	(At 3V in LP mode) Will vary in SYNC mode and with V _{DD}

5.5 DC Specifications

V_{DD} = 3.0V, C_s = 4.7 nF, C_x = 5 pF, T_a = recommended range, unless otherwise noted

Parameter	Description	Min	Typ	Max	Units	Notes
V _{DD}	Supply voltage	1.8		5.5	V	
I _{DD}	Supply current, Fast mode		203.0 246.0 378.5 542.5 729.0		μA	1.8V 2.0V 3.0V 4.0V 5.0V
I _{DDL}	Supply current, LP mode		16.5 19.5 34.0 51.5 73.5		μA	1.8V 2.0V 3.0V 4.0V 5.0V
V _{DDS}	Supply turn-on slope	10			V/s	Required for proper start-up
V _{IL}	Low input logic level			0.2 V _{DD} 0.3 V _{DD}	V	V _{DD} = 1.8V – 2.4V V _{DD} = 2.4V – 5.5V
V _{HL}	High input logic level	0.7 V _{DD} 0.6 V _{DD}			V	V _{DD} = 1.8V – 2.4V V _{DD} = 2.4V – 5.5V
V _{OL}	Low output voltage			0.5	V	OUT, 4 mA sink
V _{OH}	High output voltage	2.3			V	OUT, 1 mA source
I _{IL}	Input leakage current		<0.05	1	μA	
C _X	Load capacitance range	2		50	pF	
A _R	Acquisition resolution		9	14	bits	

5.6 Mechanical Dimensions

5.6.1 6-pin SOT23-6

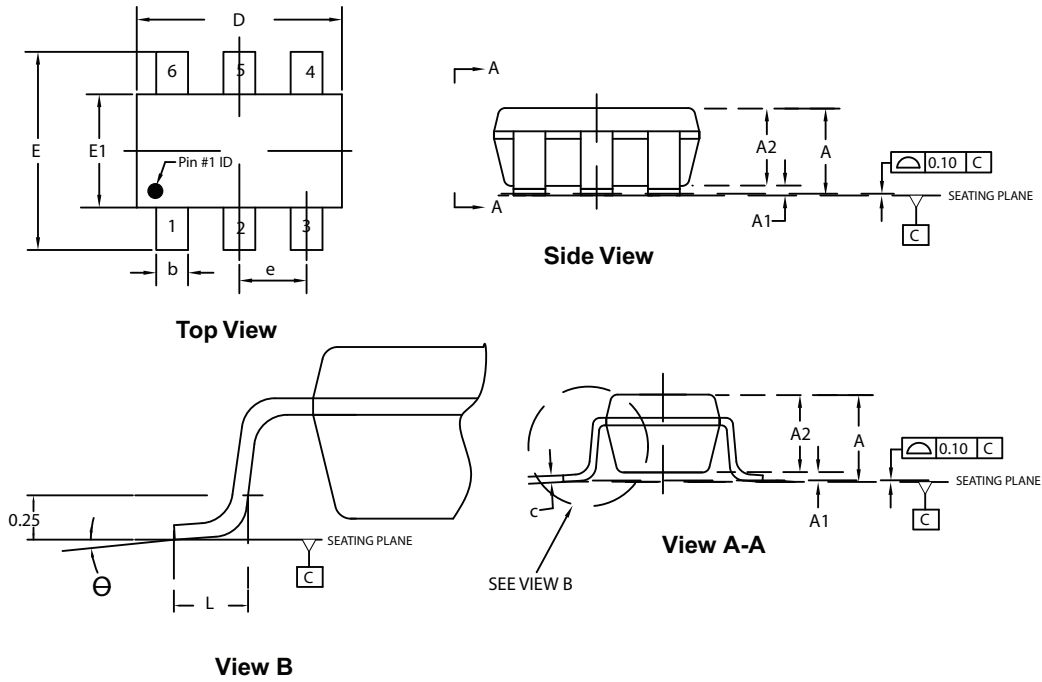

COMMON DIMENSIONS
(Unit of Measure = mm)

SYMBOL	MIN	NOM	MAX	NOTE
A	-	-	1.45	
A1	0	-	0.15	
A2	0.90	-	1.30	
D	2.80	2.90	3.00	2
E	2.60	2.80	3.00	
E1	1.50	1.60	1.75	
L	0.30	0.45	0.55	
e	0.95 BSC			
b	0.30	-	0.50	3
c	0.09	-	0.20	
θ	0°	-	8°	

- Notes:
1. This package is compliant with JEDEC specification MO-178 Variation AB
 2. Dimension D does not include mold Flash, protrusions or gate burrs. Mold Flash, protrusion or gate burrs shall not exceed 0.25 mm per end.
 3. Dimension b does not include dambar protrusion. Allowable dambar protrusion shall not cause the lead width to exceed the maximum b dimension by more than 0.08 mm
 4. Die is facing down after trim/form.

6/30/08



Package Drawing Contact:
packagedrawings@atmel.com

TITLE
6ST1, 6-lead, 2.90 x 1.60 mm Plastic Small Outline
Package (SOT23)

GPC
TAQ

DRAWING NO.
6ST1

REV.
A



5.6.2 8-pin UDFN/USON

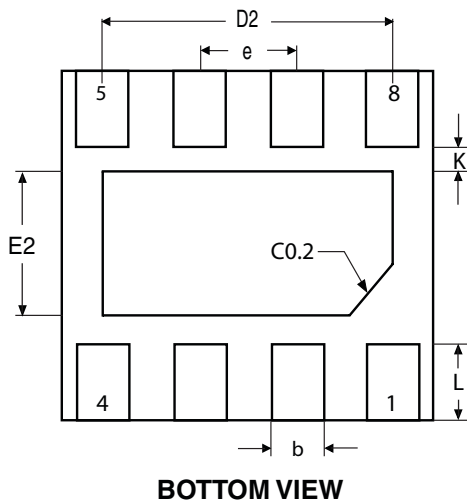

COMMON DIMENSIONS
(Unit of Measure = mm)

SYMBOL	MIN	NOM	MAX	NOTE
A	-	-	0.60	
A1	0.00	-	0.05	
b	0.20	-	0.30	
D	1.95	2.00	2.05	
D2	1.40	1.50	1.60	
E	1.95	2.00	2.05	
E2	0.80	0.90	1.00	
e	-	0.50	-	
L	0.20	0.30	0.40	
K	0.20	-	-	

- Note:
1. ALL DIMENSIONS ARE IN mm. ANGLES IN DEGREES.
 2. COPLANARITY APPLIES TO THE EXPOSED PAD AS WELL AS THE TERMINALS COPLANARITY SHALL NOT EXCEED 0.05 mm.
 3. WARPAGE SHALL NOT EXCEED 0.05 mm.
 4. REFER JEDEC MO-236/MO-252

12/17/09



Package Drawing Contact:
packagedrawings@atmel.com

TITLE
8PAD, 2x2x0.6 mm body, 0.5 mm pitch,
0.9x1.5 mm exposed pad, Saw singulated
Thermally enhanced plastic ultra thin dual flat
no lead package (UDFN/USON)

GPC
YAG

DRAWING NO.
8MA4

REV.
A

5.7 Part Marking

5.7.1 AT42QT1010– 6-pin SOT23-6

Note: Samples of the AT42QT1010 may also be marked **T10E**.

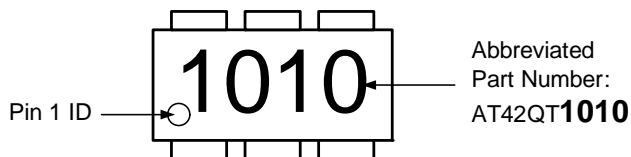

5.7.2 AT42QT1010– 8-pin UDFN/USON

Note: Samples of the AT42QT1010 may also be marked **T10**.

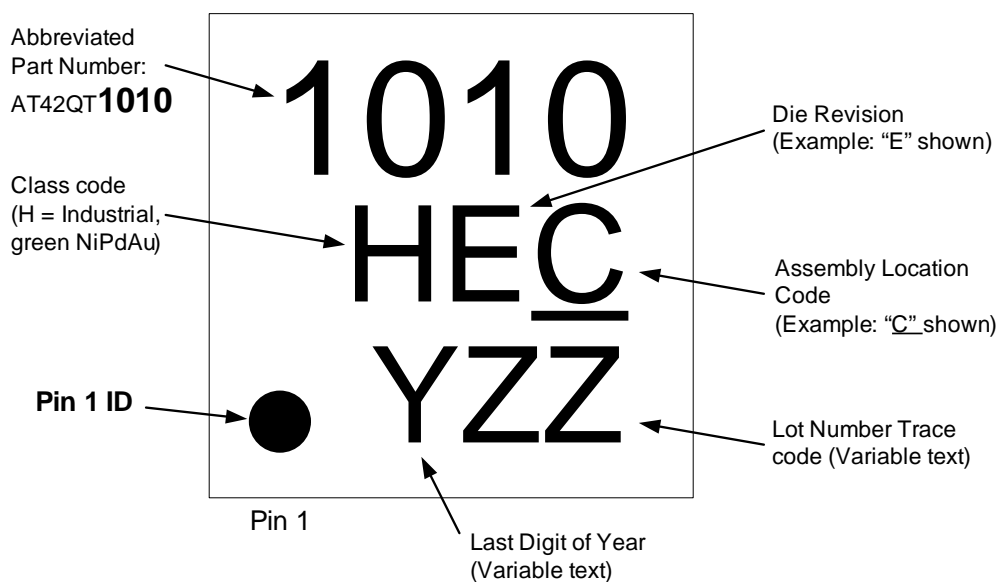

5.8 Part Number

Part Number	Description
AT42QT1010-TSHR	6-pin SOT23 RoHS compliant IC
AT42QT1010-MAH	8-pin UDFN/USON RoHS compliant IC

5.9 Moisture Sensitivity Level (MSL)

MSL Rating	Peak Body Temperature	Specifications
MSL1	260°C	IPC/JEDEC J-STD-020

Appendix A. Migrating from QT100A

Note: This appendix applies to the use of the SOT23-6 package only.

A.1 Introduction

This appendix describes the issues that should be considered when migrating designs from the QT100A to the QT1010.

A.2 Cs Capacitor

The Cs Capacitor should be increased in value, assuming that other factors, such as the voltage level and electrode size, remain the same. For example, at 3V, a Cs value of 4.7 nF should be increased to 8.2 nF.

A.3 PCB Layout

There are no PCB layout issues. The 6-pin WSON package used by the QT100A shares a common footprint with the 6-pin SOT23-6 package used by the QT1010. Both packages share the same pinouts.

A.4 Power Consumption

The QT1010 has a range of 1.8 to 5.5V for V_{dd}, compared with 2.0 to 5.5V on the QT100A.

Notice should also be taken of the differences in power consumption in both Fast and LP operation modes.

Associated Documents

For additional information, refer to the following document (downloadable from the Touch Technology area of Atmel's website, www.atmel.com):

- *Touch Sensors Design Guide*
- QTAN0002 – *Secrets of a Successful QTouch® Design*

Revision History

Revision No.	History
Revision A – May 2009	<ul style="list-style-type: none"> • Initial release
Revision B – August 2009	<ul style="list-style-type: none"> • Update for chip revision 2.2
Revision C – August 2009	<ul style="list-style-type: none"> • Minor update for clarity
Revision D – January 2010	<ul style="list-style-type: none"> • Power specifications updated for revision 2.4.1
Revision E – January 2010	<ul style="list-style-type: none"> • Part markings updated
Revision F – February 2010	<ul style="list-style-type: none"> • MSL specification revised • Other minor updates
Revision G – March 2010	<ul style="list-style-type: none"> • Update for chip revision 2.6 • Migration advice added
Revision H – May 2010	<ul style="list-style-type: none"> • UDFN/USON package added



Headquarters

Atmel Corporation
2325 Orchard Parkway
San Jose, CA 95131
USA
Tel: 1(408) 441-0311
Fax: 1(408) 487-2600

International

Atmel Asia
Unit 01-05 & 16, 19/F
BEA Tower, Millennium City 5
418 Kwun Tong Road
Kwun Tong
Kowloon
Hong Kong
Tel: (852) 2245-6100
Fax: (852) 2722-1369

Atmel Europe
Le Krebs
8, Rue Jean-Pierre Timbaud
BP 309
78054 Saint-Quentin-en-
Yvelines Cedex
France
Tel: (33) 1-30-60-70-00
Fax: (33) 1-30-60-71-11

Atmel Japan
9F, Tonetsu Shinkawa Bldg.
1-24-8 Shinkawa
Chuo-ku, Tokyo 104-0033
Japan
Tel: (81) 3-3523-3551
Fax: (81) 3-3523-7581

Touch Technology Division

1 Mitchell Point
Ensign Way
Hamble
Southampton
Hampshire SO31 4RF
United Kingdom
Tel: (44) 23-8056-5600
Fax: (44) 23-8045-3939

Product Contact

Web Site
www.atmel.com

Technical Support
touch@atmel.com

Sales Contact
www.atmel.com/contacts

Literature Requests
www.atmel.com/literature

Disclaimer: The information in this document is provided in connection with Atmel products. No license, express or implied, by estoppel or otherwise, to any intellectual property right is granted by this document or in connection with the sale of Atmel products. **EXCEPT AS SET FORTH IN ATMEL'S TERMS AND CONDITIONS OF SALE LOCATED ON ATMEL'S WEB SITE, ATMEL ASSUMES NO LIABILITY WHATSOEVER AND DISCLAIMS ANY EXPRESS, IMPLIED OR STATUTORY WARRANTY RELATING TO ITS PRODUCTS INCLUDING, BUT NOT LIMITED TO, THE IMPLIED WARRANTY OF MERCHANTABILITY, FITNESS FOR A PARTICULAR PURPOSE, OR NON-INFRINGEMENT. IN NO EVENT SHALL ATMEL BE LIABLE FOR ANY DIRECT, INDIRECT, CONSEQUENTIAL, PUNITIVE, SPECIAL OR INCIDENTAL DAMAGES (INCLUDING, WITHOUT LIMITATION, DAMAGES FOR LOSS OF PROFITS, BUSINESS INTERRUPTION, OR LOSS OF INFORMATION) ARISING OUT OF THE USE OR INABILITY TO USE THIS DOCUMENT, EVEN IF ATMEL HAS BEEN ADVISED OF THE POSSIBILITY OF SUCH DAMAGES.** Atmel makes no representations or warranties with respect to the accuracy or completeness of the contents of this document and reserves the right to make changes to specifications and product descriptions at any time without notice. Atmel does not make any commitment to update the information contained herein. Unless specifically provided otherwise, Atmel products are not suitable for, and shall not be used in, automotive applications. Atmel's products are not intended, authorized, or warranted for use as components in applications intended to support or sustain life.

© 2009 – 2010 Atmel Corporation. All rights reserved. Atmel®, Atmel logo and combinations thereof, QTouch® and others are registered trademarks, QT™, HeartBeat™ and others are trademarks of Atmel Corporation or its subsidiaries. Other terms and product names may be registered trademarks or trademarks of others.