



DI200~DI2010

DUAL-IN-LINE GLASS PASSIVATED SINGLE-PHASE BRIDGE RECTIFIER

VOLTAGE 50~1000 Volts **CURRENT** 2.0 Amperes

DIP Unit : inch (mm)

FEATURES

- Plastic material used carries Underwriters Laboratory recognition 94V-0
- Low leakage
- Surge overload rating-- 50 amperes peak
- Ideal for printed circuit board
- Exceeds environmental standards of MIL-S-19500/228
- In compliance with EU RoHS 2002/95/EC directives

MECHANICAL DATA

- Case: Reliable low cost construction utilizing molded plastic technique results in inexpensive product
- Terminals: Lead solderable per MIL-STD-750, Method 2026
- Polarity: Polarity symbols molded or marking on body
- Mounting Position: Any
- Weight: 0.0115 ounce, 0.3268 gram

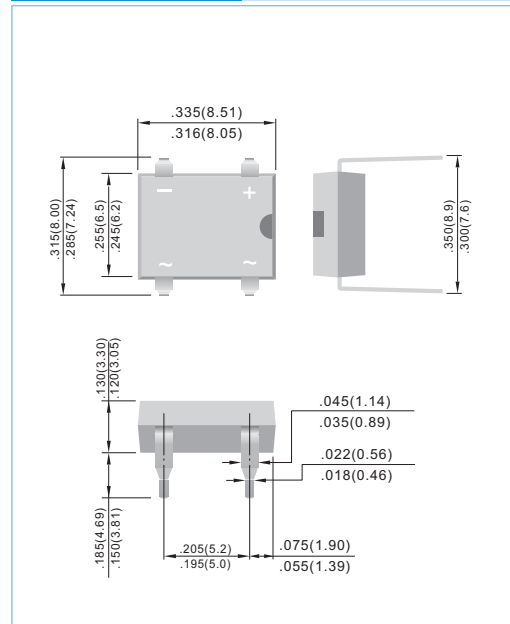

MAXIMUM RATINGS AND ELECTRICAL CHARACTERISTICS

Ratings at 25°C ambient temperature unless otherwise specified. Single phase, half wave, 60Hz, Resistive or inductive load.
For capacitive load, derate current by 20%

PARAMETER	SYMBOL	DI200	DI201	DI202	DI204	DI206	DI208	DI2010	UNITS
Maximum Recurrent Peak Reverse Voltage	V_{RRM}	50	100	200	400	600	800	1000	V
Maximum RMS Bridge Input Voltage	V_{RMS}	35	70	140	280	420	560	700	V
Maximum DC Blocking Voltage	V_{DC}	50	100	200	400	600	800	1000	V
Maximum Average Forward Current $T_A=40^\circ\text{C}$	$I_{F(AV)}$	2.0							A
Peak Forward Surge Current: 8.3ms single half sine-wave superimposed on rated load (JEDEC method)	I_{FSM}	50							A
I^2t Rating for fusing ($t < 8.35\text{ms}$)	I^2t	10.0							A^2S
Maximum Forward Voltage Drop per Bridge Element at 2.0A	V_F	1.1							V
Maximum DC Reverse Current $T_J=25^\circ\text{C}$ at Rated DC Blocking Voltage $T_J=125^\circ\text{C}$	I_R	5.0 500							μA
Typical Junction capacitance (Note 1)	C_J	25							pF
Typical thermal resistance per leg ((Note 2)	$R_{\theta JA}$ $R_{\theta JL}$	40 15							$^\circ\text{C} / \text{W}$
Operating Junction and Storage Temperature Range	T_J, T_{STG}	-55 to + 150							$^\circ\text{C}$

NOTES:

1. Measured at 1.0 MHz and applied reverse voltage of 4.0 Volts
2. Thermal resistance from junction to ambient and from junction to lead mounted on P.C.B. with 0.5 X 0.5"(13 X 13mm) copper pads



DI200~DI2010

RATING AND CHARACTERISTIC CURVES

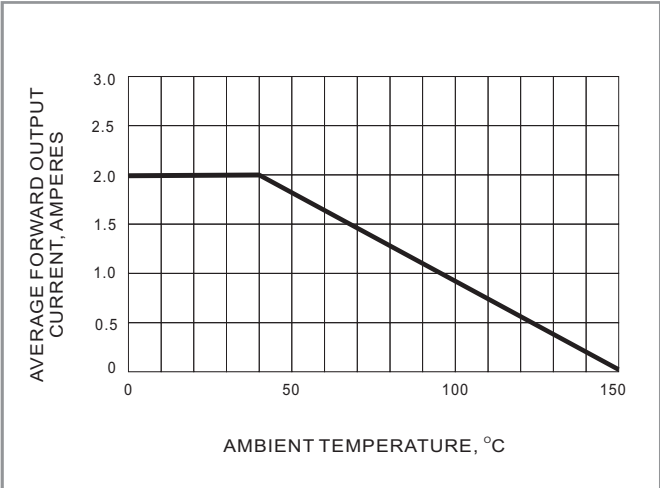

FIG. 1 DERATING CURVE FOR OUTPUT RECTIFIED CURRENT

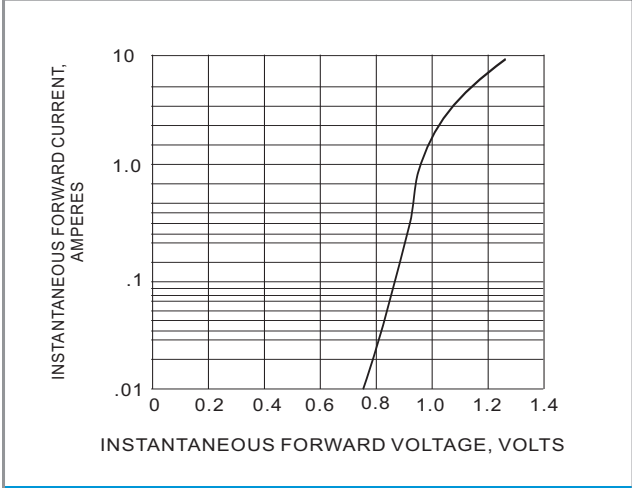

Fig.2 TYPICAL INSTANTANEOUS FORWARD CHARACTERISTICS

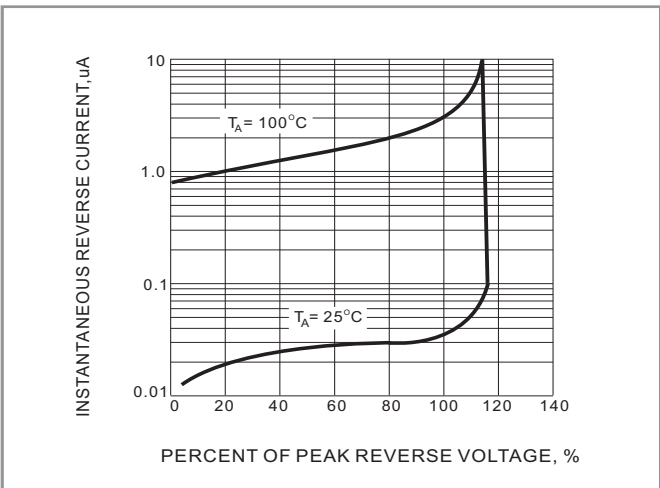

FIG. 3 TYPICAL REVERSE CHARACTERISTICS

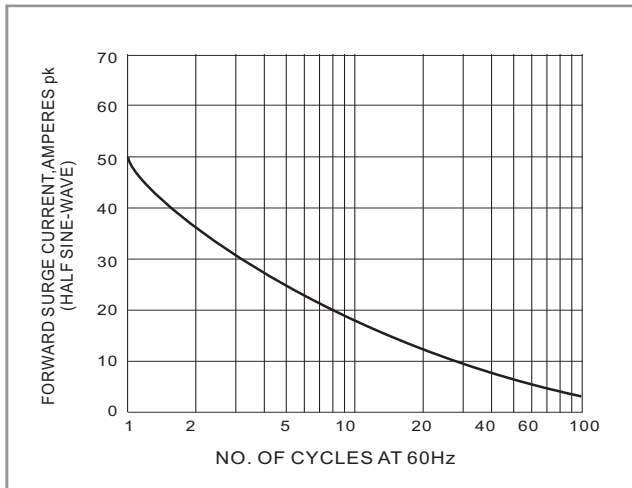

Fig.4 MAXIMUM NON-REPETITIVE PEAK FORWARD SURGE CURRENT