



RS1AWZ SERIES

SURFACE MOUNT FAST RECOVERY RECTIFIER

VOLTAGE 50 to 1000 Volts **CURRENT** 1.0 Amperes

SMA(W)

Unit : inch(mm)

FEATURES

- For surface mounted applications
- Low profile package
- Built-in strain relief
- Easy pick and place
- Fast Recovery times for high efficiency
- Plastic package has Underwriters Laboratory Flammability Classification 94V-O
- Glass Passivated Junction
- In compliance with EU RoHS 2002/95/EC directives

MECHANICAL DATA

- Case: SMA(W) molded plastic
- Terminals: Solder plated, solderable per MIL-STD-750, Method 2026
- Polarity: Color band denotes cathode end
- Standard packaging: 12mm tape (EIA-481)
- Weight: 0.002 ounce, 0.064 gram

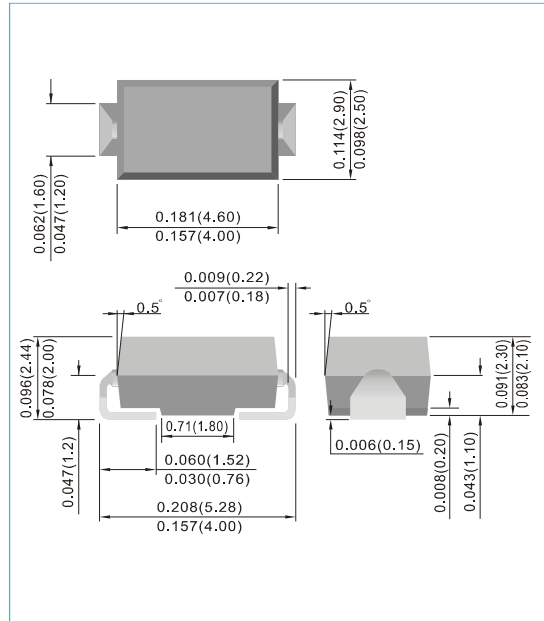

MAXIMUM RATINGS AND ELECTRICAL CHARACTERISTICS

Ratings at 25°C ambient temperature unless otherwise specified. Single phase, half wave, 60 Hz, resistive or inductive load. For capacitive load, derate current by 20%.

PARAMETER	SYMBOL	RS1AWZ	RS1BWZ	RS1DWZ	RS1GWZ	RS1JWZ	RS1KWZ	RS1MWZ	UNITS
Maximum Recurrent Peak Reverse Voltage	V_{RRM}	50	100	200	400	600	800	1000	V
Maximum RMS Voltage	V_{RMS}	35	70	140	280	420	560	800	V
Maximum DC Blocking Voltage	V_{DC}	50	100	200	400	600	800	1000	V
Maximum Average Rectified Current at $T_L=90^\circ\text{C}$	$I_{F(AV)}$	1.0							A
Peak Forward Surge Current : 8.3ms single half sine-wave superimposed on rated load(JEDEC method)	I_{FSM}	30							A
Maximum Forward Voltage at 1.0A	V_F	1.3							V
Maximum DC Reverse Current at Rated DC Blocking Voltage $T_J=25^\circ\text{C}$ $T_J=125^\circ\text{C}$	I_R	5.0 150							μA
Maximum Reverse Recovery Time (Note 1)	t_{rr}	150				250	500		ns
Maximum Junction Capacitance (Note 2)	C_j	12							pF
Typical Junction Resistance (Note 3)	$R_{\theta JA}$ $R_{\theta JL}$	100 32							$^\circ\text{C} / \text{W}$
Operating Junction and Storage Temperature Rating	T_J, T_{STG}	-55 to +150							$^\circ\text{C}$

NOTES:1. Reverse Recovery Test Conditions: $I_F=0.5\text{A}$, $I_R=1.0\text{A}$, $I_{rr}=0.25\text{A}$

2. Measured at 1 MHz and applied $V_r = 4.0$ volts.

3. 8.0 mm^2 (.013mm thick) land areas.



RS1AWZ SERIES

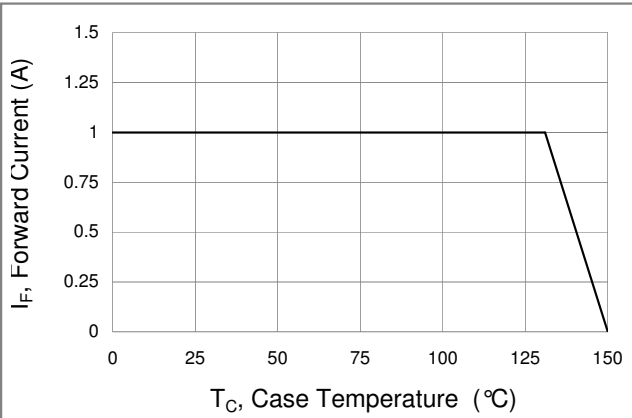

Fig.1 Forward Current Derating Curve

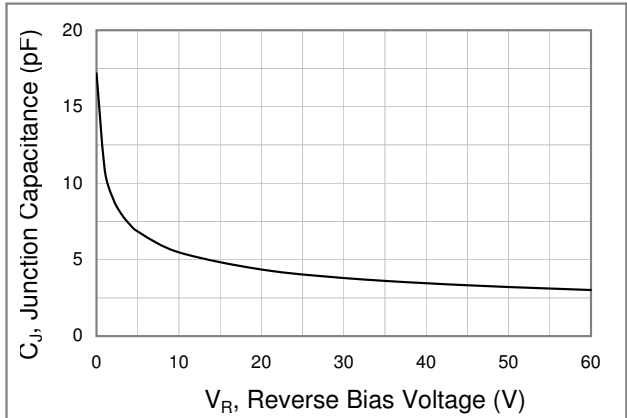

Fig.2 Typical Junction Capacitance

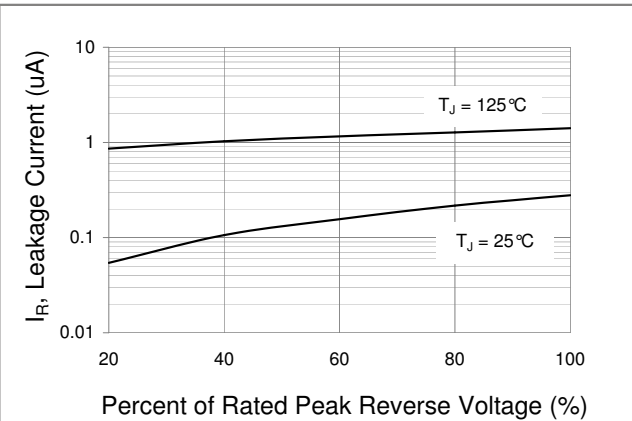

Fig.3 Typical Reverse Characteristics

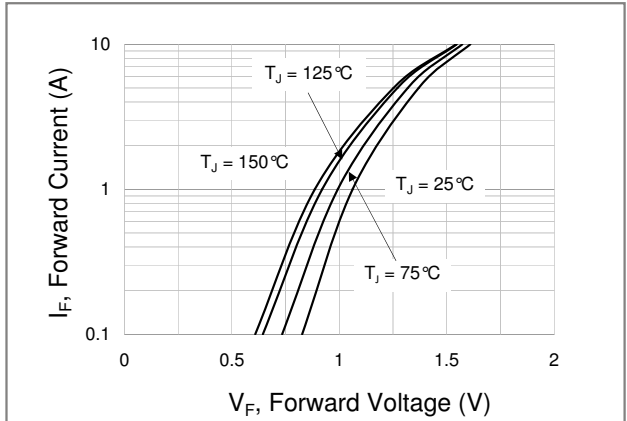
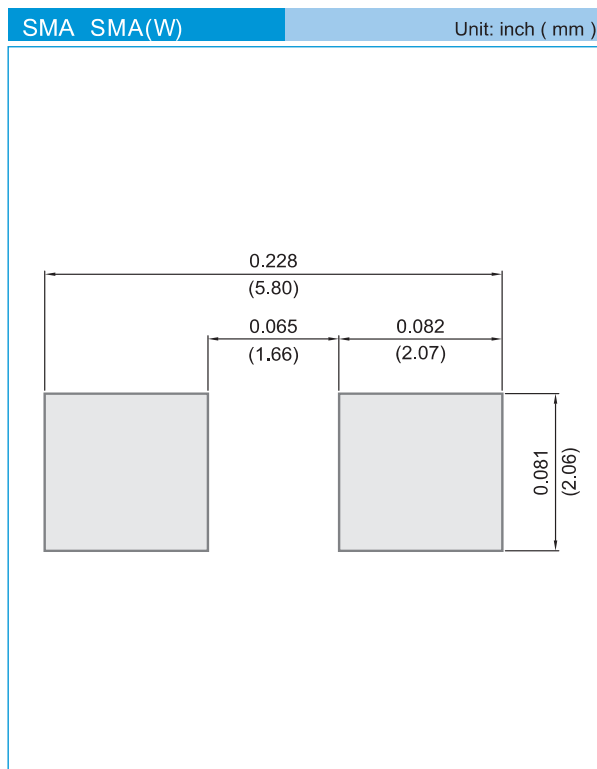

Fig.4 Typical Forward Characteristics



RS1AWZ SERIES

MOUNTING PAD LAYOUT



ORDER INFORMATION

- Packing information
 - T/R - 7.5K per 13" plastic Reel
 - T/R - 1.8Kper 7" plastic Reel

LEGAL STATEMENT

Copyright PanJit International, Inc 2011

The information presented in this document is believed to be accurate and reliable. The specifications and information herein are subject to change without notice. Pan Jit makes no warranty, representation or guarantee regarding the suitability of its products for any particular purpose. Pan Jit products are not authorized for use in life support devices or systems. Pan Jit does not convey any license under its patent rights or rights of others.