



MMBD4150

SURFACE MOUNT SWITCHING DIODES

VOLTAGE 50 Volts **POWER** 300 mWatts

SOT-23 Unit : inch(mm)

FEATURES

- Very fast reverse recovery($T_{RR}<2.0\text{ns}$ typical)
- Low capacitance(4pF@0V typical)
- Surface Mount Package Ideally Suited for Automatic Insertion
- Lead free in comply with EU RoHS 2002/95/EC directives.
- Green molding compound as per IEC61249 Std. . (Halogen Free)

MECHANICAL DATA

- Case : SOT-23 plastic case.
- Terminals : Solderable per MIL-STD-750,Method 2026
- Standard packaging : 8mm tape
- Approx.Weight : 0.0003 ounces, 0.0084grams
- Marking : A5

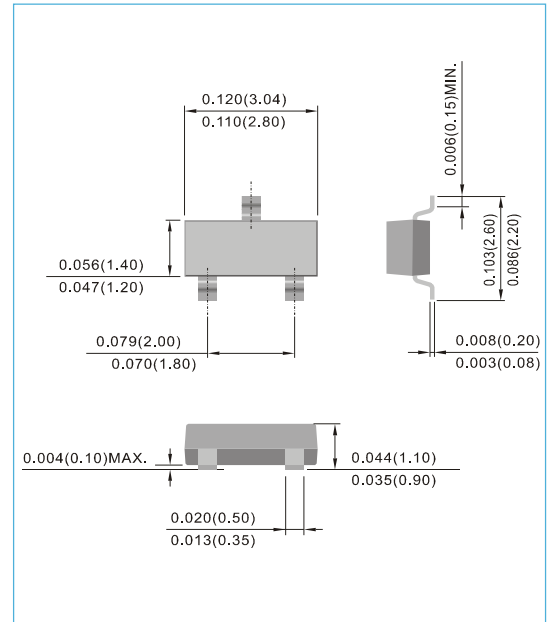
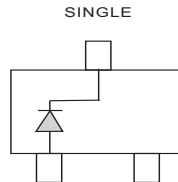

MAXIMUM RATINGS AND ELECTRICAL CHARACTERISTICS ($T_A=25^\circ\text{C}$ unless otherwise noted)

PARAMETER	SYMBOL	Value	UNITS
Maximum Reverse Voltage	V_R	50	V
Peak Reverse Voltage	V_{RRM}	50	V
Maximum Average Forward Current	$I_{F(AV)}$	250	mA
Non-repetitive Peak Forward Surge Current at $t=1.0\text{s}$	I_{FSM}	1	A
Power Dissipation (Note 1)	P_{TOT}	300	mW
Maximum Reverse Current at 50V	I_R	100	nA
Maximum Forward Voltage at $I_F=200\text{mA}$	V_F	1	V
Typical Junction Capacitance	C_J	1.9	pF
	$V_R=0\text{V}, f=1.0\text{MHz}$		
Maximum Reverse Recovery Time (Note 2) (Figure 1)	T_{RR}	4.0	ns
Thermal Resistance, Junction to Ambient (Note 1)	$R_{\theta JA}$	417	$^\circ\text{C/W}$
Operating Junction Temperature and Storage Temperature Range	T_J, T_{STG}	-55 to 150	$^\circ\text{C}$

NOTE:

1. Mounted on P.C.B. with minimum pad layout.
2. From $I_F=I_R=10\text{mA}, R_L=100\Omega$.



MMBD4150

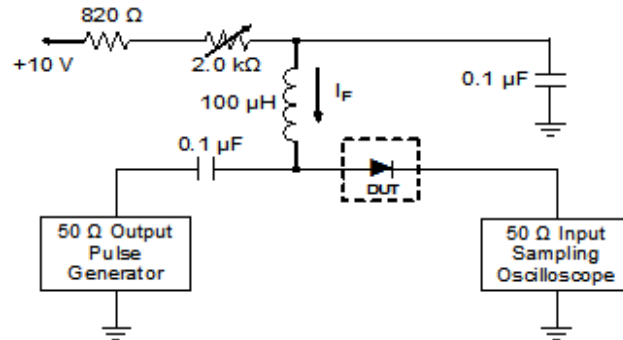

- NOTE:
1. A2.0k. variable resistor adjusted for forward current (I_F) to 10mA
 2. Input pulse is adjusted to $I_{R(peak)}$ is equal to 10mA

Figure 1. REVERSE RECOVERY TIME EQUIVALENT TEST CIRCUIT

ELECTRICAL CHARACTERISTIC CURVES

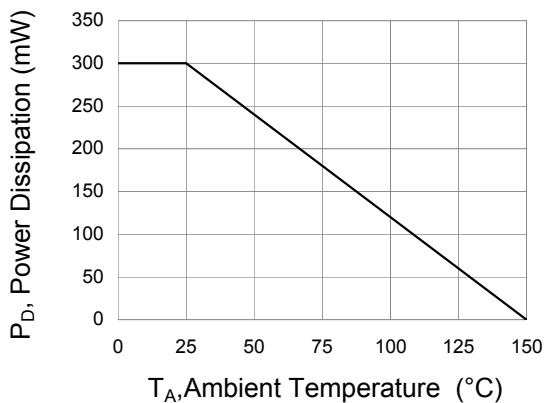

Fig.2 Power Derating Curve

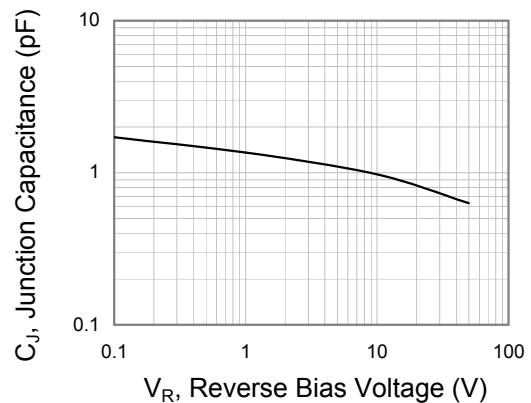

Fig.3 Typical Junction Capacitance

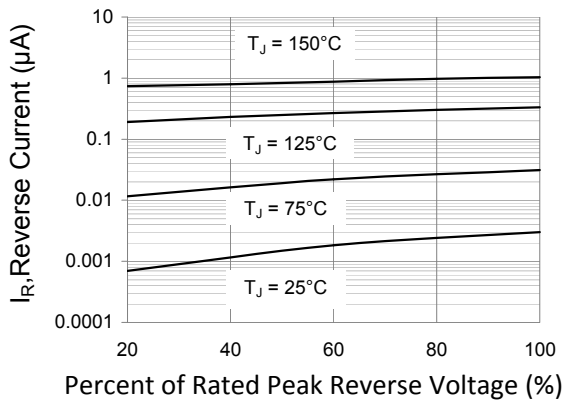

Fig.4 Typical Reverse Characteristics

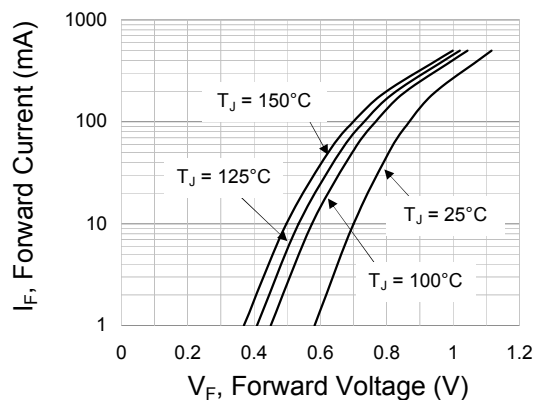
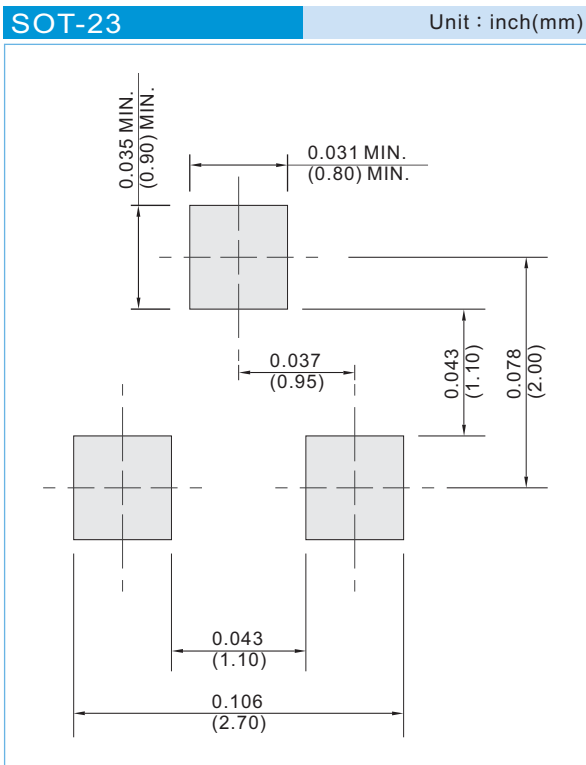

Fig.5 Typical Forward Characteristics



MMBD4150

MOUNTING PAD LAYOUT



ORDER INFORMATION

- Packing information
 - T/R - 12K per 13" plastic Reel
 - T/R - 3K per 7" plastic Reel

LEGAL STATEMENT

Copyright PanJit International, Inc 2012

The information presented in this document is believed to be accurate and reliable. The specifications and information herein are subject to change without notice. Pan Jit makes no warranty, representation or guarantee regarding the suitability of its products for any particular purpose. Pan Jit products are not authorized for use in life support devices or systems. Pan Jit does not convey any license under its patent rights or rights of others.