



## Maximum Ratings

Rating	Symbol	Value	Unit
DC Supply Voltage	$V_{DD}$	5.0	Vdc
DC Supply Current	$I_{DD}$	60	mA
Operating Ambient Temperature	$T_A$	-40 to 85	°C
Storage Temperature Range	$T_{stg}$	-65 to 150	°C
Lead Soldering Temperature Range	–	260	°C

**Note:** Maximum Ratings are those values beyond which damage to the device may occur. Functional operation should be restricted to the limits in the Electrical Characteristics tables.

## Electrical Characteristics (VCC = 2.7 to 3.3 V; TA = -40 to 85°C; Enable = 2.7 V unless otherwise noted)

Characteristic	Symbol	Min	Typ	Max	Unit
<b>Total Device</b>					
Supply Voltage	$V_{CC}$	2.7	3.0	3.3	V
Supply Current (TA = 25°C, VCC = 2.7 V, Enable = 2.7V)	$I_{CC}$	–	28	36	mA
Supply Current (TA = 25°C, VCC = 2.7 V, Enable = 2.7V)	$I_{CC}$	–	2.0	4.0	mA
<b>RF Amplifier</b>					
RF Input Frequency	$f_{in}$	–	1575.42	–	MHz
Input Impedance	$Z_{in}$	–	50	–	$\Omega$
Input VSWR	$VSWR_{in}$	–	2.0	–	–
Gain	G	13	15	–	dB
Noise Figure	NF	–	2.0	–	dB
1.0 dB Compression (Measured at Output)	$P_{1dB}$	–	1.0	–	dBm
<b>First Mixer</b>					
Input Frequency	$f_{in}$	–	1575.42	–	MHz
Gain	G	10	14	–	dB
Noise Figure	NF	–	13	–	dB
1.0 dB compression (Measured at Output)	$P_{1dB}$	–	-13	–	dBm
First Local Oscillator Frequency	$f_{LO1}$	–	1636.8	–	MHz
First Intermediate Frequency	$f_{IF1}$	–	61.38	–	MHz
LO Leakage at IF Port	–	–	-40	–	dBm
LO Leakage at RF Port	–	–	-50	–	dBm
Output Impedance	$Z_{out}$	–	50	–	$\Omega$
<b>First IF Amplifier and Second Mixer</b>					
Input Frequency	$f_{in}$	–	61.38	–	MHz
Input Impedance	$Z_{in}$	–	230	–	$\Omega$
Output Impedance	$Z_{out}$	–	50	–	$\Omega$
Second Local Oscillator Frequency	$f_{LO2}$	–	65.47	–	MHz
Second Intermediate Frequency	$f_{IF2}$	–	4.092	–	MHz
LO Leakage at IF Port	–	–	-40	–	dBm
Gain	G	40	43	–	dB
Cascaded Noise Figure	NF	–	9.3	–	dB
1.0 dB Compression Point (Measured at Output)	$P_{1dB}$	–	-13	–	dBm
<b>Limiting Amplifier</b>					
Second Intermediate Frequency	$f_{IF2}$	–	4.092	–	MHz
Input Signal Level	–	4.0	11	31	Mv
Output Voltage Swing (into 10 pF    100 k $\Omega$ )	$V_{out}$	800	–	–	mVpp
DC Output Level	–	–	1.4	–	V
Gain	G	–	50	–	dB
<b>Reference Oscillator</b>					
Reference Frequency	$f_r$	–	16.368	–	MHz
Reference Frequency Input Level (Crystal Output Pin)	–	–	500	–	mVpp

**Electrical Characteristics** (VCC = 2.7 to 3.3 V; TA = -40 to 85°C; Enable = 2.7 V unless otherwise noted)

Characteristic	Symbol	Min	Typ	Max	Unit
Reference Oscillator Output Voltage Level (Into 15 pf    10 kΩ)	–	750	–	–	mVpp
Reference Clock Input Drive Level	–	400	800	1500	mVpp
<b>PLL</b>					
First Local Oscillator Frequency	f <sub>LO1</sub>	–	1636.8	–	MHz
Second Local Oscillator Frequency	f <sub>LO2</sub>	–	65.47	–	MHz
VCO C/N (at 10 kHz Offset)	–	–	-80	–	dBc/Hz
VCO Gain (TBD Varactor)	–	–	200	–	MHz/V
<b>Enable</b>					
Enable Active Level	–	0.8 x V <sub>CC</sub>	V <sub>CC</sub>	–	V
Disable Active Level	–	–	0	0.2 x V <sub>CC</sub>	V
<b>Voltage Regulator</b>					
Regulator Output Voltage (V <sub>CC</sub> = 2.7 to 3.3 V, I <sub>out</sub> = 3.0 mA)	V <sub>O</sub>	2.1	2.3	2.5	V
<b>MRFIC505 Temperature Sense Specs</b>					
Temperature Sensor Output Voltage @ 25°C	–	1.2	1.28	1.375	V
Temperature Sensor Slope over Temperature	–	–	5.0	–	mV/°C
<b>MRFIC505A Temperature Sense Specs</b>					
Temperature Sensor Output Voltage @ 25°C	–	1.270	1.395	1.463	V
Temperature Sensor Slope over Temperature	–	–	5.0	–	mV/°C

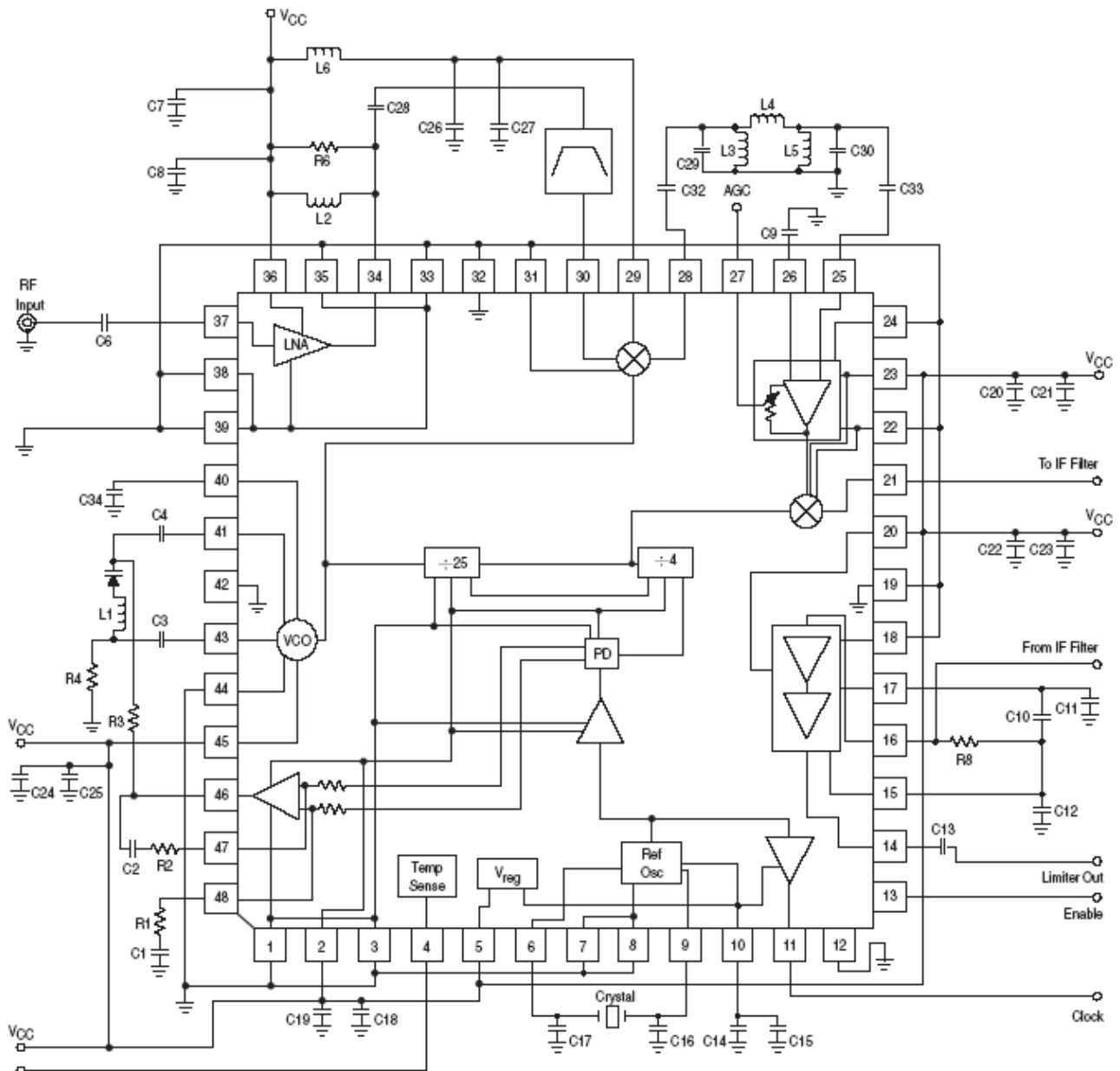

Temp Sense	C1, C2	220 pF	C29, C30	91 pF
	C3, C4	1.7 pF	C32, C33	1.0 nF
	C6	10 pF	L1	10 nH
	C7, C14, C18, C20, C22, C24, C34	0.01 μF	L2	3.9 nH
	C8, C15, C19, C21, C23, C25, C27	1000 pF	L3, L5	82 nH
	C9	1.0 μF	L4	0.62 μH
	C10, C11, C12	1.0 nF	L6	TBD
	C13	2.7 nF	R1, R2, R4	10 k
	C16, C17	27 pF	R3	2 k
	C26	470 pF	R6	1.2 k
	C28	0.6 pF	R8	5.0 k

NOTES: 1. R8 must be set to match your 2nd IF filter impedance.  
 2. Layout of capacitors C10, C11, C12 is critical for stability of Limiter.

Figure 1 Applications Schematic (1636.8 MHz LO)

# Outline Dimensions

PLASTIC PACKAGE  
CASE 932-03  
(LQFP-48)  
ISSUE F

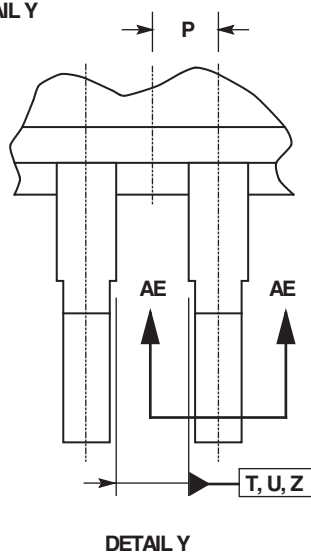
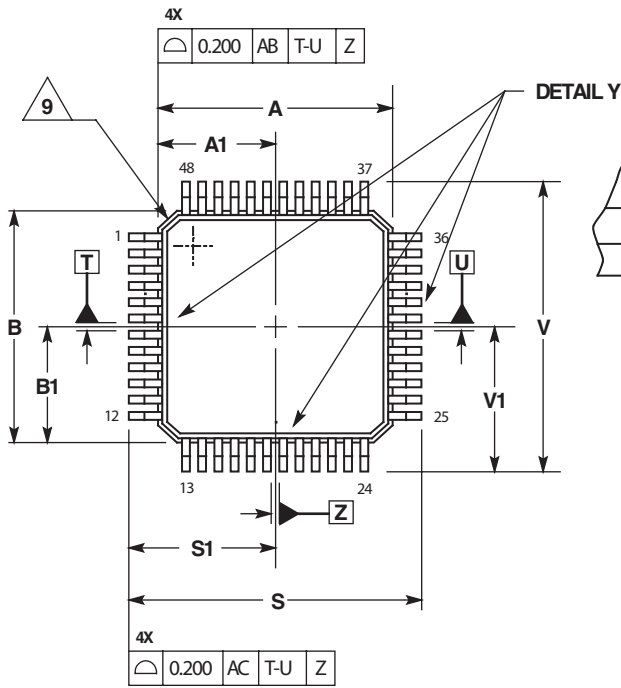

- NOTEDIMENSIONING AND TOLERANCING PER ASME
- 3 DIMENSION A1 IS THE DIAMETER OF LEAD AND IS COINCIDENT WITH THE LEAD WHERE THE LEAD EXITS THE PLASTIC BODY AT
  - 4 DIMENSION A1 SHOULD BE DETERMINED AT
  - 5 DIMENSION A AND V TO BE DETERMINED AT
  - 6 DIMENSIONS A AND B DO NOT INCLUDE MOLD PROTRUSION. ALLOWABLE PROTRUSION IS 0.250 PER SIDE. DIMENSIONS A AND B DO INCLUDE MOLD MISMATCH AND ARE
  - 7 DIMENSIONS C AND D DO NOT INCLUDE DAMBAR PROTRUSION. DAMBAR PROTRUSION SHALL NOT CAUSE THE D DIMENSION TO EXCEED
  - 8 MINIMUM SOLDER PLATE THICKNESS SHALL BE
  - 9 EXAMPLE: CHAMFER OF EACH CORNER IS OPTIONAL

DIM	MILLIMETERS	
	MIN	MAX
A	7.000	BSC
A1	3.500	BSC
B	7.000	BSC
B1	3.500	BSC
C	1.400	1.600
D	0.170	0.270
E	1.350	1.450
F	0.170	0.230
G	0.500	BSC
H	0.050	0.150
J	0.090	0.200
K	0.500	0.700
L	0	7 δ
M	12	REF
N	0.090	0.160
P	0.250	BSC
R	0.150	0.250
S	9.000	BSC
S1	4.500	BSC
V	9.000	BSC
V1	4.500	BSC
W	0.200	REF
AA	1.000	REF

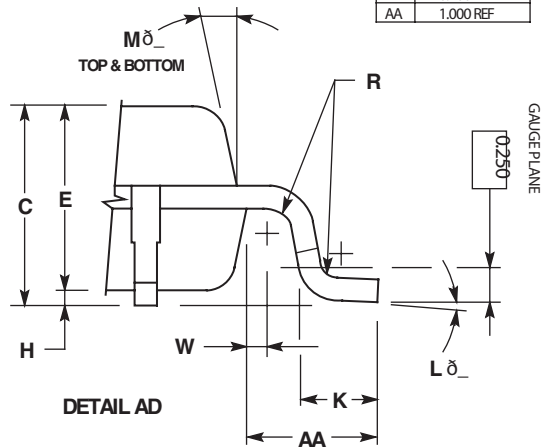
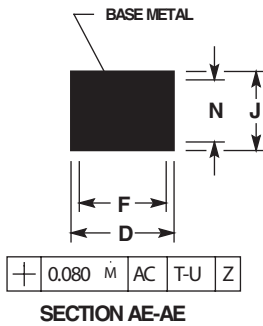
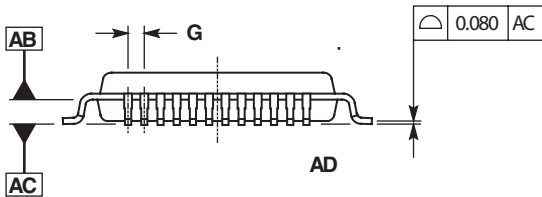

---

# NOTES

---

# NOTES

## **How to Reach Us:**

### **Home Page:**

[www.freescale.com](http://www.freescale.com)

### **E-mail:**

[support@freescale.com](mailto:support@freescale.com)

### **USA/Europe or Locations Not Listed:**

Freescale Semiconductor  
Technical Information Center, CH370  
1300 N. Alma School Road  
Chandler, Arizona 85224  
+1-800-521-6274 or +1-480-768-2130  
[support@freescale.com](mailto:support@freescale.com)

### **Europe, Middle East, and Africa:**

Freescale Halbleiter Deutschland GmbH  
Technical Information Center  
Schatzbogen 7  
81829 Muenchen, Germany  
+44 1296 380 456 (English)  
+46 8 52200080 (English)  
+49 89 92103 559 (German)  
+33 1 69 35 48 48 (French)  
[support@freescale.com](mailto:support@freescale.com)

### **Japan:**

Freescale Semiconductor Japan Ltd.  
Technical Information Center  
3-20-1, Minami-Azabu, Minato-ku  
Tokyo 106-0047, Japan  
0120 191014 or +81 3 3440 3569  
[support.japan@freescale.com](mailto:support.japan@freescale.com)

### **Asia/Pacific:**

Freescale Semiconductor Hong Kong Ltd.  
Technical Information Center  
2 Dai King Street  
Tai Po Industrial Estate  
Tai Po, N.T., Hong Kong  
+800 2666 8080  
[support.asia@freescale.com](mailto:support.asia@freescale.com)

### **For Literature Requests Only:**

Freescale Semiconductor Literature Distribution Center  
P.O. Box 5405  
Denver, Colorado 80217  
1-800-441-2447 or 303-675-2140  
Fax: 303-675-2150  
[LDCForFreescaleSemiconductor@hibbertgroup.com](mailto:LDCForFreescaleSemiconductor@hibbertgroup.com)

RoHS-compliant and/or Pb- free versions of Freescale products have the functionality and electrical characteristics of their non-RoHS-compliant and/or non-Pb- free counterparts. For further information, see <http://www.freescale.com> or contact your Freescale sales representative.

For information on Freescale's Environmental Products program, go to <http://www.freescale.com/epp>.

Information in this document is provided solely to enable system and software implementers to use Freescale Semiconductor products. There are no express or implied copyright licenses granted hereunder to design or fabricate any integrated circuits or integrated circuits based on the information in this document.

Freescale Semiconductor reserves the right to make changes without further notice to any products herein. Freescale Semiconductor makes no warranty, representation or guarantee regarding the suitability of its products for any particular purpose, nor does Freescale Semiconductor assume any liability arising out of the application or use of any product or circuit, and specifically disclaims any and all liability, including without limitation consequential or incidental damages. "Typical" parameters that may be provided in Freescale Semiconductor data sheets and/or specifications can and do vary in different applications and actual performance may vary over time. All operating parameters, including "Typicals", must be validated for each customer application by customer's technical experts. Freescale Semiconductor does not convey any license under its patent rights nor the rights of others. Freescale Semiconductor products are not designed, intended, or authorized for use as components in systems intended for surgical implant into the body, or other applications intended to support or sustain life, or for any other application in which the failure of the Freescale Semiconductor product could create a situation where personal injury or death may occur. Should Buyer purchase or use Freescale Semiconductor products for any such unintended or unauthorized application, Buyer shall indemnify and hold Freescale Semiconductor and its officers, employees, subsidiaries, affiliates, and distributors harmless against all claims, costs, damages, and expenses, and reasonable attorney fees arising out of, directly or indirectly, any claim of personal injury or death associated with such unintended or unauthorized use, even if such claim alleges that Freescale Semiconductor was negligent regarding the design or manufacture of the part.



Freescale™ and the Freescale logo are trademarks of Freescale Semiconductor, Inc. All other product or service names are the property of their respective owners.

© Freescale Semiconductor, Inc. 2004. All rights reserved.