



MRFG35005NT1 replaced by MRFG35005ANT1.

Gallium Arsenide PHEMT

RF Power Field Effect Transistor

Designed for WLL/MMDS/BWA or UMTS driver applications with frequencies from 1.8 to 3.6 GHz. Device is unmatched and is suitable for use in Class AB linear base station applications.

- Typical W-CDMA Performance: -42 dBc ACPR, 3.55 GHz, 12 Volts, $I_{DQ} = 80$ mA, 5 MHz Offset/3.84 MHz BW, 64 DPCH (8.5 dB P/A @ 0.01% Probability)
 - Output Power — 450 mWatt
 - Power Gain — 11 dB
 - Efficiency — 25%
- 4.5 Watts P1dB @ 3.55 GHz
- Excellent Phase Linearity and Group Delay Characteristics
- High Gain, High Efficiency and High Linearity
- N Suffix Indicates Lead-Free Terminations. RoHS Compliant.
- In Tape and Reel. T1 Suffix = 1000 Units per 12 mm, 7 inch Reel.

MRFG35005NT1

**3.5 GHz, 4.5 W, 12 V
 POWER FET
 GaAs PHEMT**

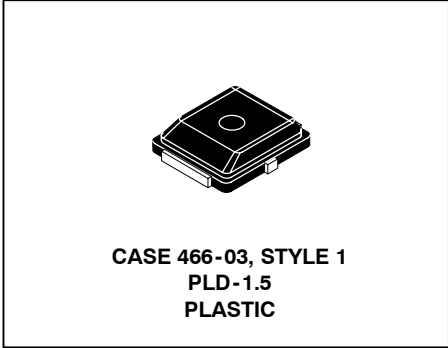

ARCHIVE INFORMATION

ARCHIVE INFORMATION

Table 1. Maximum Ratings

Rating	Symbol	Value	Unit
Drain-Source Voltage	V_{DSS}	15	Vdc
Total Device Dissipation @ $T_C = 25^\circ\text{C}$ Derate above 25°C	P_D	10.5 ⁽²⁾ 0.07 ⁽²⁾	W W/ $^\circ\text{C}$
Gate-Source Voltage	V_{GS}	-5	Vdc
RF Input Power	P_{in}	30	dBm
Storage Temperature Range	T_{stg}	-65 to +150	$^\circ\text{C}$
Channel Temperature ⁽¹⁾	T_{ch}	175	$^\circ\text{C}$
Operating Case Temperature Range	T_C	-20 to +85	$^\circ\text{C}$

Table 2. Thermal Characteristics

Characteristic	Symbol	Value	Unit
Thermal Resistance, Junction to Case Class AB	$R_{\theta JC}$	14.2 ⁽²⁾	$^\circ\text{C}/\text{W}$

Table 3. Moisture Sensitivity Level

Test Methodology	Rating	Package Peak Temperature	Unit
Per JESD 22-A113, IPC/JEDEC J-STD-020	1	260	$^\circ\text{C}$

1. For reliable operation, the operating channel temperature should not exceed 150°C .
2. Simulated.

Table 4. Electrical Characteristics ($T_C = 25^\circ\text{C}$ unless otherwise noted)

Characteristic	Symbol	Min	Typ	Max	Unit
Saturated Drain Current ($V_{DS} = 3.5 \text{ Vdc}$, $V_{GS} = 0 \text{ Vdc}$)	I_{DSS}	—	1.7	—	Adc
Off State Leakage Current ($V_{GS} = -0.4 \text{ Vdc}$, $V_{DS} = 0 \text{ Vdc}$)	I_{GSS}	—	< 1.0	100	μAdc
Off State Drain Current ($V_{DS} = 12 \text{ Vdc}$, $V_{GS} = -2.5 \text{ Vdc}$)	I_{DSO}	—	—	600	μAdc
Off State Current ($V_{DS} = 28.5 \text{ Vdc}$, $V_{GS} = -2.5 \text{ Vdc}$)	I_{DSX}	—	< 1.0	9	mAdc
Gate-Source Cut-off Voltage ($V_{DS} = 3.5 \text{ Vdc}$, $I_{DS} = 8.7 \text{ mA}$)	$V_{GS(th)}$	-1.2	-0.9	-0.7	Vdc
Quiescent Gate Voltage ($V_{DS} = 12 \text{ Vdc}$, $I_D = 80 \text{ mA}$)	$V_{GS(Q)}$	-1.1	-0.8	-0.6	Vdc
Power Gain ($V_{DD} = 12 \text{ Vdc}$, $I_{DQ} = 80 \text{ mA}$, $f = 3.55 \text{ GHz}$)	G_{ps}	10	11	—	dB
Output Power, 1 dB Compression Point ($V_{DD} = 12 \text{ Vdc}$, $I_{DQ} = 80 \text{ mA}$, $f = 3.55 \text{ GHz}$)	P_{1dB}	—	4.5	—	W
Drain Efficiency ($V_{DD} = 12 \text{ Vdc}$, $I_{DQ} = 80 \text{ mA}$, $P_{out} = 450 \text{ mW Avg.}$, $f = 3.55 \text{ GHz}$)	η_D	22	25	—	%
Adjacent Channel Power Ratio ($V_{DD} = 12 \text{ Vdc}$, $P_{out} = 450 \text{ mW Avg.}$, $I_{DQ} = 80 \text{ mA}$, $f = 3.55 \text{ GHz}$, W-CDMA, 8.5 P/A @ 0.01% Probability, 64 CH, 3.84 MCPS)	ACPR	—	-42	-39	dBc

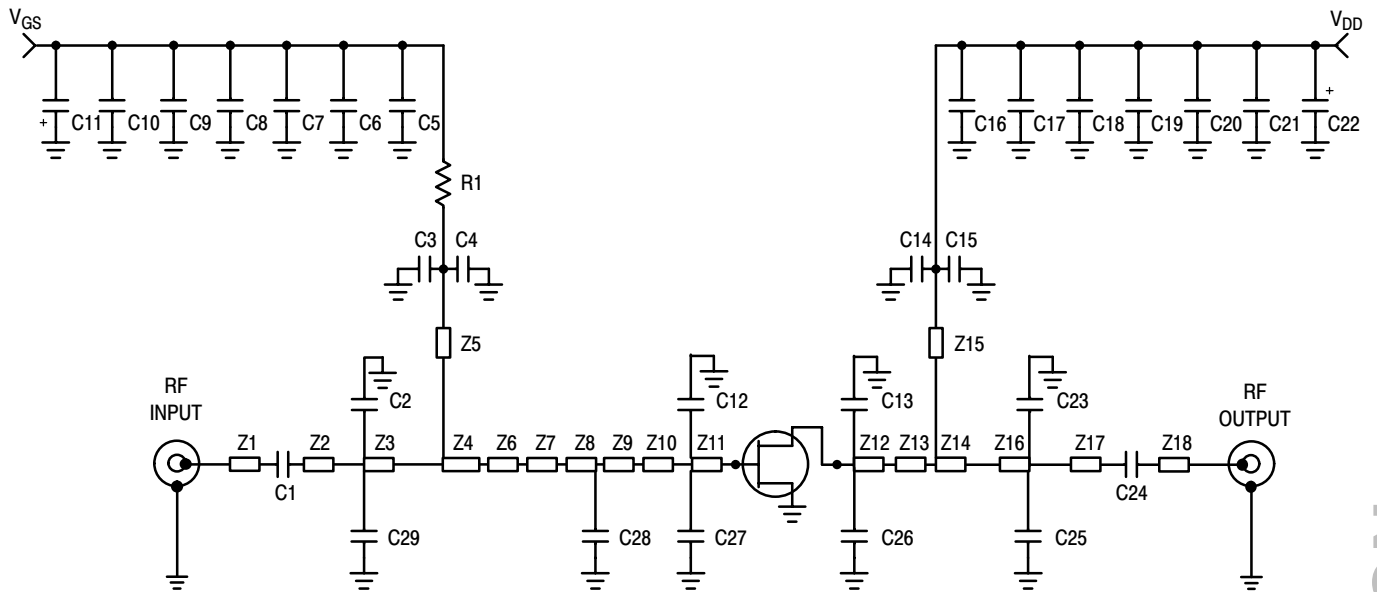

Z1, Z18	0.125" x 0.044" Microstrip	Z11	0.400" x 0.081" Microstrip
Z2	0.435" x 0.044" Microstrip	Z12	0.120" x 0.408" Microstrip
Z3	0.298" x 0.254" Microstrip	Z13	0.259" x 0.058" Microstrip
Z4	0.336" x 0.590" Microstrip	Z14	0.269" x 0.348" Microstrip
Z5, Z15	0.527" x 0.015" Microstrip	Z16	0.149" x 0.062" Microstrip
Z6, Z8, Z10	0.050" x 0.025" Microstrip	Z17	0.553" x 0.044" Microstrip
Z7, Z9	0.125" x 0.025" Microstrip	PCB	Rogers 4350, 20 mil, $\epsilon_r = 3.5$

Figure 1. 3.5 GHz Test Circuit Schematic

Table 5. 3.5 GHz Test Circuit Component Designations and Values

Part	Description	Part Number	Manufacturer
C1, C24	7.5 pF Chip Capacitors	100A7R5JP150X	ATC
C2	0.4 pF Chip Capacitor (0805)	08051J0R4BBT	AVX
C3, C4, C14, C15	3.9 pF Chip Capacitors (0805)	08051J3R9BBT	AVX
C5, C16	10 pF Chip Capacitors	100A100JP500X	ATC
C6, C17	100 pF Chip Capacitors	100A101JP500X	ATC
C7, C18	100 pF Chip Capacitors	100B101JP500X	ATC
C8, C19	1000 pF Chip Capacitors	100B102JP500X	ATC
C9, C20	3.9 μ F Chip Capacitors		ATC
C10, C21	0.1 μ F Chip Capacitors		ATC
C11, C22	22 μ F, 35 V Tantalum Surface Mount Capacitors		Newark
C12, C28	0.1 pF Chip Capacitors (0805)	08051J0R1BBT	AVX
C13, C26, C27	0.3 pF Chip Capacitors (0805)	08051J0R3BBT	AVX
C23	1.0 pF Chip Capacitor (0805)	08051J1R0BBT	AVX
C25	1.2 pF Chip Capacitor (0805)	08051J1R2BBT	AVX
C29	0.9 pF Chip Capacitor (0805)	08051J0R9BBT	AVX
R1	100 Ω Chip Resistor		Newark

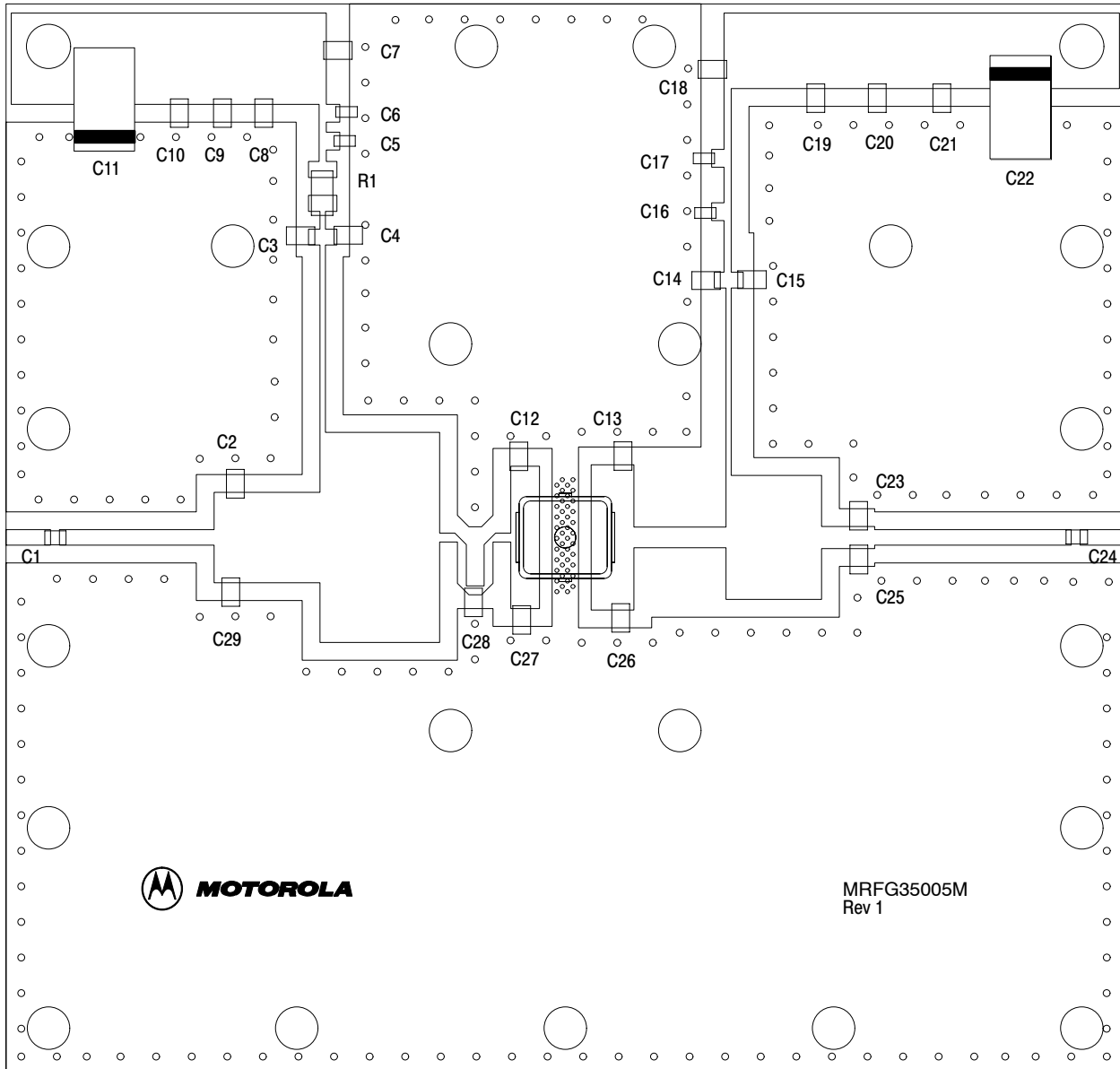

Freescale has begun the transition of marking Printed Circuit Boards (PCBs) with the Freescale Semiconductor signature/logo. PCBs may have either Motorola or Freescale markings during the transition period. These changes will have no impact on form, fit or function of the current product.

Figure 2. 3.5 GHz Test Circuit Component Layout

TYPICAL CHARACTERISTICS

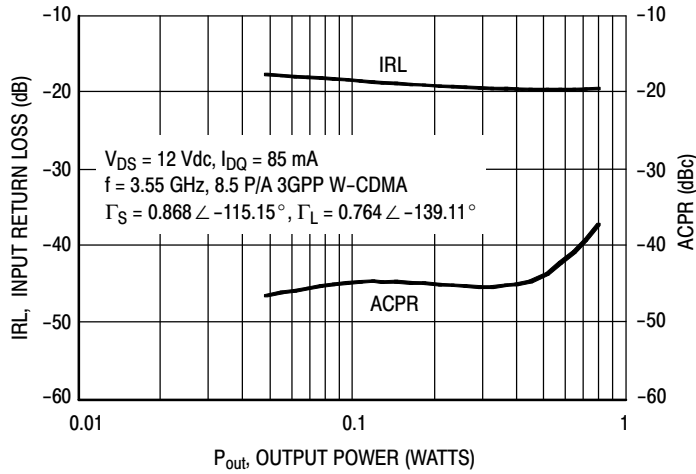

Figure 3. W-CDMA ACPR and Input Return Loss versus Output Power

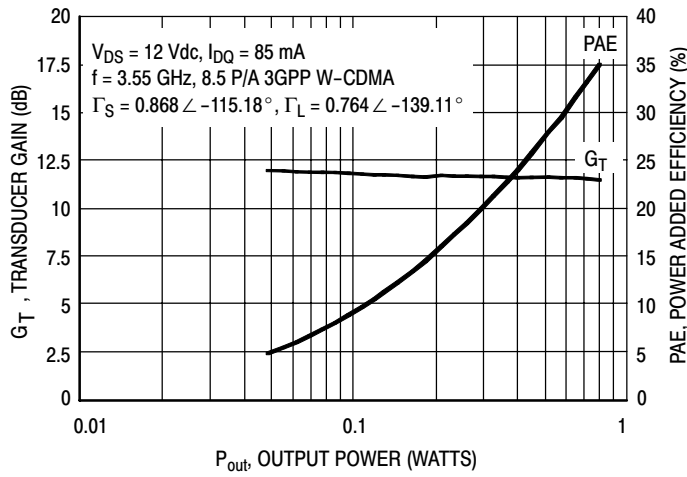

Figure 4. Transducer Gain and Power Added Efficiency versus Output Power

NOTE: All data is referenced to package lead interface. Γ_S and Γ_L are the impedances presented to the DUT. All data is generated from load pull, not from the test circuit shown.

Table 6. Class AB Common Source S-Parameters at $V_{DS} = 12$ Vdc, $I_{DQ} = 85$ mA

f GHz	S_{11}		S_{21}		S_{12}		S_{22}	
	$ S_{11} $	$\angle \phi$	$ S_{21} $	$\angle \phi$	$ S_{12} $	$\angle \phi$	$ S_{22} $	$\angle \phi$
0.50	0.903	-171.71	7.441	83.44	0.029	4.18	0.604	-171.44
0.55	0.903	-173.53	6.807	81.55	0.030	3.31	0.603	-172.51
0.60	0.901	-175.37	6.268	79.64	0.030	2.49	0.602	-173.76
0.65	0.901	-177.11	5.817	77.76	0.030	1.53	0.602	-175.04
0.70	0.902	-178.58	5.441	75.93	0.030	0.64	0.602	-176.15
0.75	0.900	179.95	5.096	74.17	0.030	-0.21	0.600	-177.32
0.80	0.901	178.58	4.804	72.37	0.030	-0.90	0.600	-178.45
0.85	0.901	177.36	4.516	70.46	0.030	-1.80	0.600	-179.44
0.90	0.899	176.17	4.293	68.89	0.030	-2.30	0.599	179.38
0.95	0.899	174.93	4.089	67.19	0.030	-3.17	0.600	178.20
1.00	0.901	173.84	3.900	65.58	0.030	-4.01	0.600	177.19
1.05	0.900	172.74	3.730	63.88	0.030	-4.63	0.600	176.10
1.10	0.899	171.57	3.567	62.18	0.031	-5.38	0.600	175.06
1.15	0.900	170.42	3.423	60.54	0.031	-6.01	0.601	174.08
1.20	0.899	169.31	3.284	58.91	0.031	-6.66	0.601	173.04
1.25	0.898	168.10	3.154	57.19	0.031	-7.52	0.602	171.90
1.30	0.901	166.96	3.040	55.59	0.031	-8.14	0.602	171.14
1.35	0.897	165.99	2.928	54.05	0.031	-8.73	0.600	170.54
1.40	0.903	164.48	2.821	52.41	0.031	-9.30	0.606	169.31
1.45	0.901	163.52	2.720	50.95	0.031	-9.89	0.606	168.98
1.50	0.900	160.23	2.618	49.25	0.030	-10.77	0.607	170.81
1.55	0.900	159.17	2.537	47.79	0.030	-11.27	0.609	170.02
1.60	0.899	158.30	2.456	46.40	0.030	-11.82	0.609	169.38
1.65	0.902	157.39	2.386	44.91	0.030	-12.27	0.609	168.87
1.70	0.903	156.46	2.317	43.49	0.030	-12.67	0.610	168.03
1.75	0.902	155.63	2.251	41.97	0.030	-13.06	0.613	167.41
1.80	0.903	154.92	2.195	40.59	0.030	-13.50	0.612	166.88
1.85	0.904	154.09	2.137	39.12	0.030	-13.91	0.613	165.94
1.90	0.904	153.38	2.080	37.80	0.030	-14.35	0.615	165.27
1.95	0.903	152.74	2.030	36.43	0.030	-14.79	0.615	164.72
2.00	0.906	152.00	1.984	34.98	0.030	-15.36	0.615	163.90
2.05	0.905	151.41	1.937	33.71	0.030	-15.79	0.618	163.26
2.10	0.904	150.85	1.897	32.47	0.031	-16.26	0.619	162.83
2.15	0.906	150.13	1.860	31.10	0.031	-16.74	0.617	162.02
2.20	0.906	149.60	1.822	29.77	0.031	-17.43	0.619	161.22
2.25	0.905	149.11	1.788	28.49	0.031	-17.97	0.620	160.82
2.30	0.906	148.41	1.761	27.10	0.031	-18.45	0.619	160.12
2.35	0.906	147.74	1.729	25.78	0.031	-18.73	0.620	159.20
2.40	0.904	147.11	1.701	24.47	0.031	-19.16	0.620	158.79
2.45	0.903	146.23	1.677	22.98	0.031	-19.61	0.620	158.15
2.50	0.902	145.41	1.651	21.58	0.031	-20.07	0.619	157.20
2.55	0.901	144.66	1.632	20.17	0.031	-20.42	0.621	156.64
2.60	0.899	143.78	1.612	18.88	0.032	-20.71	0.619	156.02
2.65	0.899	142.76	1.591	17.38	0.032	-21.29	0.618	155.10
2.70	0.898	141.87	1.571	15.88	0.032	-21.77	0.619	154.49
2.75	0.894	140.80	1.554	14.50	0.033	-22.47	0.618	154.05
2.80	0.895	139.70	1.539	12.83	0.033	-23.36	0.616	153.08

ARCHIVE INFORMATION

ARCHIVE INFORMATION

Table 6. Class AB Common Source S-Parameters at $V_{DS} = 12$ Vdc, $I_{DQ} = 85$ mA (continued)

f GHz	S_{11}		S_{21}		S_{12}		S_{22}	
	$ S_{11} $	$\angle \phi$	$ S_{21} $	$\angle \phi$	$ S_{12} $	$\angle \phi$	$ S_{22} $	$\angle \phi$
2.85	0.895	138.63	1.522	11.37	0.034	-24.77	0.618	152.46
2.90	0.893	137.48	1.507	9.90	0.034	-26.15	0.618	151.97
2.95	0.893	136.05	1.493	8.24	0.034	-27.11	0.616	150.93
3.00	0.894	134.72	1.478	6.55	0.034	-27.92	0.618	150.06
3.05	0.892	133.46	1.465	4.95	0.034	-28.51	0.617	149.53
3.10	0.890	131.81	1.453	3.30	0.034	-29.31	0.616	148.45
3.15	0.892	130.31	1.436	1.60	0.034	-29.98	0.616	147.51
3.20	0.891	128.98	1.421	0.04	0.034	-30.69	0.617	146.90
3.25	0.888	127.31	1.409	-1.72	0.034	-31.47	0.615	145.95
3.30	0.890	125.83	1.394	-3.40	0.034	-32.45	0.616	145.01
3.35	0.889	124.49	1.380	-4.89	0.034	-33.06	0.616	144.44
3.40	0.887	122.78	1.367	-6.59	0.034	-33.59	0.615	143.59
3.45	0.889	121.40	1.352	-8.31	0.034	-34.06	0.615	142.69
3.50	0.888	119.96	1.338	-9.91	0.035	-34.46	0.616	141.92
3.55	0.887	118.32	1.328	-11.56	0.035	-35.34	0.615	141.09
3.60	0.888	116.96	1.313	-13.16	0.035	-36.09	0.613	140.03
3.65	0.887	115.68	1.299	-14.69	0.036	-36.68	0.613	139.19
3.70	0.887	114.24	1.287	-16.36	0.036	-37.71	0.612	138.40
3.75	0.887	113.05	1.274	-17.90	0.036	-38.84	0.612	137.36
3.80	0.888	111.84	1.262	-19.43	0.036	-39.90	0.613	136.45
3.85	0.888	110.59	1.252	-20.85	0.036	-40.73	0.613	135.74
3.90	0.887	109.45	1.240	-22.36	0.036	-41.33	0.612	134.56
3.95	0.888	108.32	1.230	-24.01	0.036	-41.73	0.613	133.64
4.00	0.887	107.24	1.222	-25.35	0.036	-42.00	0.612	133.05
4.05	0.886	106.10	1.216	-26.93	0.037	-42.60	0.611	131.91
4.10	0.887	105.02	1.205	-28.43	0.037	-43.13	0.611	130.81
4.15	0.886	104.22	1.198	-29.78	0.037	-43.70	0.609	130.15
4.20	0.884	103.08	1.195	-31.44	0.038	-44.59	0.607	128.89
4.25	0.885	102.00	1.189	-33.00	0.038	-45.54	0.608	127.57
4.30	0.885	101.08	1.184	-34.46	0.038	-46.22	0.608	126.81
4.35	0.884	100.08	1.183	-35.96	0.039	-46.93	0.605	125.63
4.40	0.883	98.90	1.176	-37.67	0.039	-48.09	0.606	124.16
4.45	0.882	97.99	1.172	-39.19	0.039	-49.06	0.607	123.26
4.50	0.881	96.91	1.176	-40.74	0.040	-49.87	0.604	122.03
4.55	0.880	95.41	1.172	-42.48	0.040	-50.58	0.603	120.40
4.60	0.879	94.29	1.172	-44.02	0.040	-51.24	0.601	119.45
4.65	0.878	92.80	1.177	-45.83	0.041	-52.21	0.597	118.22
4.70	0.877	91.10	1.175	-47.87	0.042	-53.61	0.594	116.51
4.75	0.876	89.66	1.176	-49.70	0.042	-55.11	0.594	115.24
4.80	0.874	87.90	1.178	-51.58	0.042	-56.51	0.590	113.89
4.85	0.874	86.08	1.177	-53.56	0.042	-57.66	0.589	112.15
4.90	0.870	84.39	1.175	-55.56	0.042	-58.60	0.588	110.76
4.95	0.867	82.48	1.177	-57.53	0.043	-59.41	0.585	109.40
5.00	0.866	80.32	1.179	-59.75	0.043	-60.39	0.583	107.71

ARCHIVE INFORMATION

ARCHIVE INFORMATION

PACKAGE DIMENSIONS

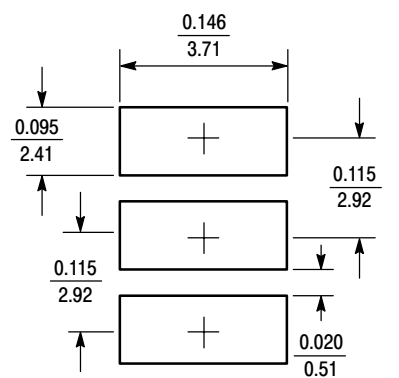
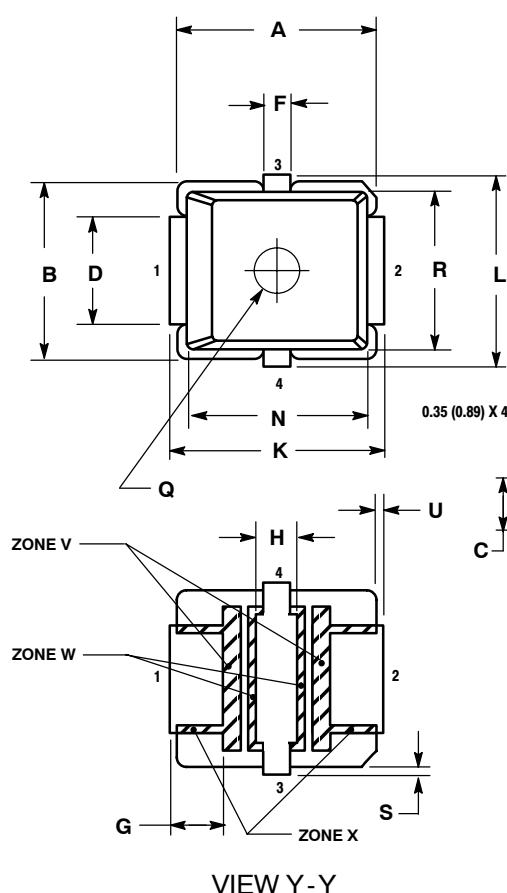

SOLDER FOOTPRINT

DIM	INCHES		MILLIMETERS	
	MIN	MAX	MIN	MAX
A	0.255	0.265	6.48	6.73
B	0.225	0.235	5.72	5.97
C	0.065	0.072	1.65	1.83
D	0.130	0.150	3.30	3.81
E	0.021	0.026	0.53	0.66
F	0.026	0.044	0.66	1.12
G	0.050	0.070	1.27	1.78
H	0.045	0.063	1.14	1.60
J	0.160	0.180	4.06	4.57
K	0.273	0.285	6.93	7.24
L	0.245	0.255	6.22	6.48
N	0.230	0.240	5.84	6.10
P	0.000	0.008	0.00	0.20
Q	0.055	0.063	1.40	1.60
R	0.200	0.210	5.08	5.33
S	0.006	0.012	0.15	0.31
U	0.006	0.012	0.15	0.31
ZONE V	0.000	0.021	0.00	0.53
ZONE W	0.000	0.010	0.00	0.25
ZONE X	0.000	0.010	0.00	0.25

- NOTES:
1. INTERPRET DIMENSIONS AND TOLERANCES PER ASME Y14.5M, 1984.
 2. CONTROLLING DIMENSION: INCH
 3. RESIN BLEED/FLASH ALLOWABLE IN ZONE V, W, AND X.

- STYLE 1:
 PIN 1. DRAIN
 2. GATE
 3. SOURCE
 4. SOURCE

**CASE 466-03
 ISSUE D
 PLD-1.5
 PLASTIC**

ARCHIVE INFORMATION

ARCHIVE INFORMATION

REVISION HISTORY

The following table summarizes revisions to this document.

Revision	Date	Description
5	Jan. 2008	<ul style="list-style-type: none">Listed replacement part, p. 1Added Revision History, p. 9

ARCHIVE INFORMATION

ARCHIVE INFORMATION

How to Reach Us:

Home Page:

www.freescale.com

Web Support:

<http://www.freescale.com/support>

USA/Europe or Locations Not Listed:

Freescale Semiconductor, Inc.
Technical Information Center, EL516
2100 East Elliot Road
Tempe, Arizona 85284
+1-800-521-6274 or +1-480-768-2130
www.freescale.com/support

Europe, Middle East, and Africa:

Freescale Halbleiter Deutschland GmbH
Technical Information Center
Schatzbogen 7
81829 Muenchen, Germany
+44 1296 380 456 (English)
+46 8 52200080 (English)
+49 89 92103 559 (German)
+33 1 69 35 48 48 (French)
www.freescale.com/support

Japan:

Freescale Semiconductor Japan Ltd.
Headquarters
ARCO Tower 15F
1-8-1, Shimo-Meguro, Meguro-ku,
Tokyo 153-0064
Japan
0120 191014 or +81 3 5437 9125
support.japan@freescale.com

Asia/Pacific:

Freescale Semiconductor Hong Kong Ltd.
Technical Information Center
2 Dai King Street
Tai Po Industrial Estate
Tai Po, N.T., Hong Kong
+800 2666 8080
support.asia@freescale.com

For Literature Requests Only:

Freescale Semiconductor Literature Distribution Center
P.O. Box 5405
Denver, Colorado 80217
1-800-441-2447 or 303-675-2140
Fax: 303-675-2150
LDCForFreescaleSemiconductor@hibbertgroup.com

Information in this document is provided solely to enable system and software implementers to use Freescale Semiconductor products. There are no express or implied copyright licenses granted hereunder to design or fabricate any integrated circuits or integrated circuits based on the information in this document.

Freescale Semiconductor reserves the right to make changes without further notice to any products herein. Freescale Semiconductor makes no warranty, representation or guarantee regarding the suitability of its products for any particular purpose, nor does Freescale Semiconductor assume any liability arising out of the application or use of any product or circuit, and specifically disclaims any and all liability, including without limitation consequential or incidental damages. "Typical" parameters that may be provided in Freescale Semiconductor data sheets and/or specifications can and do vary in different applications and actual performance may vary over time. All operating parameters, including "Typicals", must be validated for each customer application by customer's technical experts. Freescale Semiconductor does not convey any license under its patent rights nor the rights of others. Freescale Semiconductor products are not designed, intended, or authorized for use as components in systems intended for surgical implant into the body, or other applications intended to support or sustain life, or for any other application in which the failure of the Freescale Semiconductor product could create a situation where personal injury or death may occur. Should Buyer purchase or use Freescale Semiconductor products for any such unintended or unauthorized application, Buyer shall indemnify and hold Freescale Semiconductor and its officers, employees, subsidiaries, affiliates, and distributors harmless against all claims, costs, damages, and expenses, and reasonable attorney fees arising out of, directly or indirectly, any claim of personal injury or death associated with such unintended or unauthorized use, even if such claim alleges that Freescale Semiconductor was negligent regarding the design or manufacture of the part.

Freescale™ and the Freescale logo are trademarks of Freescale Semiconductor, Inc. All other product or service names are the property of their respective owners.
© Freescale Semiconductor, Inc. 2006, 2008. All rights reserved.

RoHS-compliant and/or Pb-free versions of Freescale products have the functionality and electrical characteristics of their non-RoHS-compliant and/or non-Pb-free counterparts. For further information, see <http://www.freescale.com> or contact your Freescale sales representative.

For information on Freescale's Environmental Products program, go to <http://www.freescale.com/epp>.

