



Package: QFN, 3.0mmx3.8mmx0.85mm



Features

- Broadband Performance
Suitable for all Cellular Modulation Schemes up to 2.7 GHz
- Excellent Insertion Loss and Isolation Performance
- High Isolation Between GSM Rx Paths > 32 dB Typ.
- Five Linear Paths Offer Band Combination and Air Interface Flexibility
- Integrated Low Pass Filters on 2G Paths for Best In Class Harmonic Attenuation
- Very High Linearity - B13-2Fo, IIP2, IIP3, TBR
- GPIO Interface and Fully Spec Compliant At 1.3V Control (Min)
- Very Low Current Consumption
- Small Solution Size - No DC Blocking Capacitors Required
- Compact
3.0mmx3.8mmx0.85mm (Typ)
QFN Module

Applications

- Cellular Handset Applications
- Cellular Modems and USB Devices
- Multi-Mode GSM, EDGE, CDMA, WCDMA, LTE, and TD-SCDMA Applications

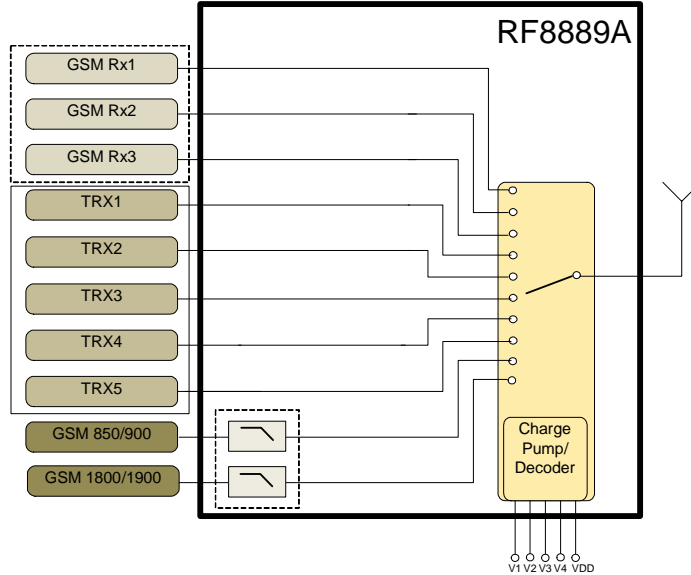

Functional Block Diagram

Product Description

The RF8889A Antenna Switch Module offers very low insertion loss along with excellent linearity performance. The RF8889A is ideal for multi-mode GSM, EDGE, CDMA, WCDMA, LTE and TD-SCDMA applications. This module integrates low pass filtering on the GSM transmit paths thus avoiding the need for external harmonic attenuation. The RF8889A is compatible with +1.8V control logic and is packaged in a compact 3.0mmx3.8mm, 26-pin, QFN package. RF8889A does not require external DC blocking capacitors enabling solution size reduction.

Ordering Information

RF8889A SP10T ANTENNA SWITCH MODULE

Optimum Technology Matching® Applied

- | | | | |
|--------------------------------------|--------------------------------------|---|------------------------------------|
| <input type="checkbox"/> GaAs HBT | <input type="checkbox"/> SiGe BiCMOS | <input type="checkbox"/> GaAs pHEMT | <input type="checkbox"/> GaN HEMT |
| <input type="checkbox"/> GaAs MESFET | <input type="checkbox"/> Si BiCMOS | <input checked="" type="checkbox"/> Si CMOS | <input type="checkbox"/> BiFET HBT |
| <input type="checkbox"/> InGaP HBT | <input type="checkbox"/> SiGe HBT | <input type="checkbox"/> Si BJT | <input type="checkbox"/> LDMOS |

RF MICRO DEVICES®, RFMD®, Optimum Technology Matching®, Enabling Wireless Connectivity™, PowerStar®, POLARIS™ TOTAL RADIO™ and UltimateBlue™ are trademarks of RFMD, LLC. BLUETOOTH is a trademark owned by Bluetooth SIG, Inc., U.S.A. and licensed for use by RFMD. All other trade names, trademarks and registered trademarks are the property of their respective owners. ©2006, RF Micro Devices, Inc.

Absolute Maximum Ratings

Parameter	Rating	Unit
V _{DD}	3.5	V
CTLA, CTLB, CTLC, CTLD	2.7	V
Maximum Input Peak Power (Instantaneous, 1:1 VSWR)		
TX1	+36, 50% DC (T _{AMB} =25 °C)	dBm
TX2	+34, 50% DC (T _{AMB} =25 °C)	dBm
TRX1 - TRX5	+32, (T _{AMB} =25 °C)	dBm
Operating Temperature	-30 to +90	°C
Storage Temperature	-65 to +150	°C



Caution! ESD sensitive device.

Exceeding any one or a combination of the Absolute Maximum Rating conditions may cause permanent damage to the device. Extended application of Absolute Maximum Rating conditions to the device may reduce device reliability. Specified typical performance or functional operation of the device under Absolute Maximum Rating conditions is not implied.

The information in this publication is believed to be accurate and reliable. However, no responsibility is assumed by RF Micro Devices, Inc. ("RFMD") for its use, nor for any infringement of patents, or other rights of third parties, resulting from its use. No license is granted by implication or otherwise under any patent or patent rights of RFMD. RFMD reserves the right to change component circuitry, recommended application circuitry and specifications at any time without prior notice.



RFMD Green: RoHS compliant per EU Directive 2002/95/EC, halogen free per IEC 61249-2-21, < 1000ppm each of antimony trioxide in polymeric materials and red phosphorus as a flame retardant, and <2% antimony in solder.

Parameter	Specification			Unit	Condition
	Min.	Typ.	Max.		
GSM850/900 Transmit					Nominal conditions unless otherwise stated. V _{DD} = 2.75 V, V _{HIGH} /V _{LOW} = 1.8 V/0 V, Temp = 25 °C, 50Ω.
Frequency Range (GSM850)	824	836.5	849	MHz	
Frequency Range (GSM900)	880	897.5	915	MHz	
Insertion Loss					
TX1 - ANT		0.95	1.30	dB	P _{IN} = 35dBm, TX1 = 824MHz to 849MHz
TX1 - ANT		1.05	1.30	dB	P _{IN} = 35dBm, TX1 = 880MHz to 915MHz
Attenuation					
TX1 - ANT, 2Fo	25	37		dB	P _{IN} = 0dBm; Freq 1648MHz to 1830MHz
TX1 - ANT, 3Fo	25	27		dB	P _{IN} = 0dBm; Freq 2472MHz to 2745MHz,
TX1 - ANT, 4Fo	20	33		dB	P _{IN} = 0dBm; Freq 3296MHz to 3660MHz
TX1 - ANT, 5Fo up to 12.75GHz	20	31		dB	P _{IN} = 0dBm; Freq 4120MHz to 12750MHz
Isolation					
TX1 - RX1	35	48		dB	TX1 = 824MHz to 915MHz
TX1 - RX2	35	46		dB	
TX1 - RX3	35	37		dB	
TX1 - TRX1	35	51		dB	
TX1 - TRX2	35	45		dB	
TX1 - TRX3	35	53		dB	
TX1 - TRX4	35	57		dB	
TX1 - TRX5	35	45		dB	
TX1 - TX2	35	39		dB	TX1 = 824MHz to 849MHz
TX1 - TX2	35	42		dB	TX1 = 1648MHz to 1830MHz
TX2 - ANT	25	27		dB	TX1 = 1710MHz to 1910MHz
Harmonics					
TX1 - ANT, 2Fo	71	99		dBc	P _{IN} = 35dBm, 25% DC
TX1 - ANT, 3Fo	71	80		dBc	
TX1 - ANT, 4Fo - 12.75GHz	71	103		dBc	
VSWR			1.25		

Parameter	Specification			Unit	Condition
	Min.	Typ.	Max.		
GSM1800/1900 Transmit					Nominal conditions unless otherwise stated. $V_{DD} = 2.75\text{ V}$, $V_{HIGH}/V_{LOW} = 1.8\text{ V}/0\text{ V}$, Temp = 25 °C, 50Ω.
Frequency Range (GSM1800)	1710	1747.5	1785	MHz	
Frequency Range (GSM1900)	1850	1880	1910	MHz	
Insertion Loss					
TX2 - ANT		1.05	1.30	dB	$P_{IN} = 32\text{ dBm}$, TX2 = 1710MHz to 1785MHz
TX2 - ANT		1.10	1.30	dB	$P_{IN} = 32\text{ dBm}$, TX2 = 1850MHz to 1910MHz
Attenuation					
TX2 - ANT, 2Fo	25	38		dB	$P_{IN} = 0\text{ dBm}$; Freq 3420 to 3820 MHz
TX2 - ANT, 3Fo	25	38		dB	$P_{IN} = 0\text{ dBm}$; Freq 5130 to 5730 MHz
TX2 - ANT, 4Fo up to 12.75GHz	20	38		dB	$P_{IN} = 0\text{ dBm}$; Freq 6840 to 12750MHz
Isolation					
TX2 - RX1	32	42		dB	TX2 = 1710MHz to 1910MHz
TX2 - RX2	32	41		dB	
TX2 - RX3	32	36		dB	
TX2 - TRX1	32	43		dB	
TX2 - TRX2	32	40		dB	
TX2 - TRX3	32	43		dB	
TX2 - TRX4	32	43		dB	
TX2 - TRX5	32	40		dB	
TX2 - TX1	40	45		dB	
TX1 - ANT	45	53		dB	
Harmonics					
TX2 - ANT, 2Fo	68	98		dBc	$P_{IN} = 32\text{ dBm}$, 25% DC
TX2 - ANT, 3Fo	68	82		dBc	
TX2 - ANT, up to 12.75GHz	68	102		dBc	
VSWR			1.36		
GSM RX1					Nominal conditions unless otherwise stated. $V_{DD} = 2.75\text{ V}$, $V_{HIGH}/V_{LOW} = 1.8\text{ V}/0\text{ V}$, Temp = 25 °C, 50Ω.
Frequency Range (RX 850)	869		894	MHz	
Frequency Range (RX900)	925		960	MHz	
Frequency Range (RX1800)	1805		1880	MHz	
Frequency Range (RX1900)	1930		1990	MHz	
Insertion Loss					
RX1 - ANT; RX850		0.65	0.85	dB	Frequency 869MHz to 894MHz
RX1 - ANT; RX900		0.65	0.85	dB	Frequency 925MHz to 960MHz
RX1 - ANT; RX1800		0.75	1.00	dB	Frequency 1805MHz to 1880MHz
RX1 - ANT; RX1900		0.75	1.00	dB	Frequency 1930MHz to 1990MHz
VSWR			1.10		
GSM RX2					Nominal conditions unless otherwise stated. $V_{DD} = 2.75\text{ V}$, $V_{HIGH}/V_{LOW} = 1.8\text{ V}/0\text{ V}$, Temp = 25 °C, 50Ω.
Frequency Range (RX 850)	869		894	MHz	
Frequency Range (RX900)	925		960	MHz	
Frequency Range (RX1800)	1805		1880	MHz	

Parameter	Specification			Unit	Condition
	Min.	Typ.	Max.		
GSM RX2 (continued)					
Frequency Range (RX1900)	1930		1990	MHz	
Insertion Loss					
RX2 - ANT; RX850		0.65	0.85	dB	Frequency 869MHz to 894MHz
RX2 - ANT; RX900		0.65	0.85	dB	Frequency 925MHz to 960MHz
RX2 - ANT; RX1800		0.75	1.00	dB	Frequency 1805MHz to 1880MHz
RX2 - ANT; RX1900		0.75	1.00	dB	Frequency 1930MHz to 1990MHz
Isolation					
RX2 - ANT (active path RX3 - ANT)	30	32		dB	Frequency 1805MHz to 1990MHz
VSWR			1.10		
GSM RX3					
Nominal conditions unless otherwise stated. $V_{DD} = 2.75\text{ V}$, $V_{HIGH}/V_{LOW} = 1.8\text{ V}/0\text{ V}$, Temp = 25 °C, 50Ω.					
Frequency Range (RX 850)	869		894	MHz	
Frequency Range (RX900)	925		960	MHz	
Frequency Range (RX1800)	1805		1880	MHz	
Frequency Range (RX1900)	1930		1990	MHz	
Insertion Loss					
RX3 - ANT; RX850		0.65	0.85	dB	Frequency 869MHz to 894MHz
RX3 - ANT; RX900		0.65	0.85	dB	Frequency 925MHz to 960MHz
RX3 - ANT; RX1800		0.80	1.00	dB	Frequency 1805MHz to 1880MHz
RX3 - ANT; RX1900		0.80	1.00	dB	Frequency 1930MHz to 1990MHz
Isolation					
RX3 - ANT (active path RX2 - ANT)	33	37		dB	Frequency 1805MHz to 1990MHz
VSWR			1.10		
UMTS TRX1 – TRX5 Low Band					
Nominal conditions unless otherwise stated. $V_{DD} = 2.75\text{ V}$, $V_{HIGH}/V_{LOW} = 1.8\text{ V}/0\text{ V}$, Temp = 25 °C, 50Ω.					
Frequency Range					
Band XII	698		716	MHz	
	728		746	MHz	
Band XIII	777		787	MHz	
	746		756	MHz	
Band V	824		849	MHz	
	869		894	MHz	
Band VIII	880		915	MHz	
	925		960	MHz	
Insertion Loss					
TRX1 - ANT		0.62	0.85	dB	698MHz to 960MHz
TRX2 - ANT		0.62	0.85	dB	
TRX3 - ANT		0.62	0.85	dB	
TRX4 - ANT		0.62	0.85	dB	
TRX5 - ANT		0.62	0.85	dB	

Parameter	Specification			Unit	Condition
	Min.	Typ.	Max.		
UMTS TRX1 - TRX5 Low Band (continued)					
Isolation					
TRX1 - TRX2	17	28		dB	824 MHz to 960 MHz
TRX1 - TRX3	30	49		dB	
TRX1 - TRX4	30	56		dB	
TRX1 - TRX5	30	44		dB	
TRX2 - TRX3	30	48		dB	
TRX2 - TRX4	30	56		dB	
TRX2 - TRX5	30	44		dB	
TRX3 - TRX4	17	30		dB	
TRX3 - TRX5	25	44		dB	
TRX4 - TRX5	17	32		dB	
TRX1 - RX1, RX2, RX3	25	39		dB	
TRX2 - RX1, RX2, RX3	30	45		dB	
TRX3 - RX1, RX2, RX3	40	51		dB	
TRX4 - RX1, RX2, RX3	40	51		dB	
TRX5 - RX1, RX2, RX3	40	50		dB	
TRX1 - TX1	45	50		dB	
TRX1 - TX2	37	45		dB	
TRX2 - TX1	50	55		dB	
TRX2 - TX2	37	44		dB	
TRX3 - TX1	50	55		dB	
TRX3 - TX2	35	41		dB	
TRX4 - TX1	50	54		dB	
TRX4 - TX2	35	41		dB	
TRX5 - TX1	48	53		dB	
TRX5 - TX2	34	40		dB	
Harmonics					
Band 13, 2Fo on TRX3		-87		dBm	$P_{IN}=25\text{dBm}$, CW, $F_o=786.5\text{MHz}$
TRX - ANT, 2Fo	68	104		dBc	$P_{IN}=26\text{dBm}$, CW
TRX - ANT, 3Fo	68	102		dBc	
TRX - ANT, up to 12.75GHz	68	103		dBc	
VSWR					
TRX1,2,3,4,5			1.20		698MHz to 960MHz

Parameter	Specification			Unit	Condition
	Min.	Typ.	Max.		
UMTS TRX1 - TRX5 High Band					Nominal conditions unless otherwise stated. $V_{DD} = 2.75\text{ V}$, $V_{HIGH}/V_{LOW} = 1.8\text{ V}/0\text{ V}$, Temp = 25 °C, 50Ω.
Frequency Range					
Band IV	1710		1755	MHz	
	2110		2115	MHz	
Band III	1710		1785	MHz	
	1805		1880	MHz	
Band II	1850		1910	MHz	
	1930		1990	MHz	
Band I	1920		1980	MHz	
	2110		2170	MHz	
Band XXXX	2300		2400		
Band VII	2500		2590	MHz	
	2620		2690	MHz	
Insertion Loss					
TRX1 - ANT		0.70	0.85	dB	$P_{IN} = 26\text{ dBm}$, CW, 1710MHz to 2170MHz
TRX2 - ANT		0.70	0.85	dB	
TRX3 - ANT		0.70	0.85	dB	
TRX4 - ANT		0.75	0.85	dB	
TRX5 - ANT		0.75	0.85	dB	
TRX1 - ANT		0.80	0.95	dB	$P_{IN} = 26\text{ dBm}$, CW, 2300MHz to 2690MHz
TRX2 - ANT		0.80	0.95	dB	
TRX3 - ANT		0.83	0.95	dB	
TRX4 - ANT		0.95	1.05	dB	
TRX5 - ANT		0.95	1.05	dB	

Parameter	Specification			Unit	Condition
	Min.	Typ.	Max.		
UMTS TRX1 - TRX5 High Band (continued)					
Isolation					
TRX1 to TRX2 1710-1880	17	22		dB	1710MHz to 1880MHz
TRX1 to TRX3 1710-1880	30	42		dB	
TRX1 to TRX4 1710-1880	30	44		dB	
TRX1 to TRX5 1710-1880	30	40		dB	
TRX2 to TRX1 1710-1880	17	24		dB	
TRX2 to TRX3 1710-1880	30	40		dB	
TRX2 to TRX4 1710-1880	30	44		dB	
TRX2 to TRX5 1710-1880	30	40		dB	
TRX3 to TRX1 1710-1880	30	41		dB	
TRX3 to TRX2 1710-1880	30	48		dB	
TRX3 to TRX4 1710-1880	17	23		dB	
TRX3 to TRX5 1710-1880	25	35		dB	
TRX4 to TRX1 1710-1880	30	42		dB	
TRX4 to TRX2 1710-1880	30	55		dB	
TRX4 to TRX3 1710-1880	17	23		dB	
TRX4 to TRX5 1710-1880	17	25		dB	
TRX5 to TRX1 1710-1880	30	42		dB	
TRX5 to TRX2 1710-1880	30	53		dB	
TRX5 to TRX3 1710-1880	30	33		dB	
TRX5 to TRX4 1710-1880	17	25		dB	
TRX1 to RX1, RX2, RX3 1710-1880	23	32		dB	

Parameter	Specification			Unit	Condition
	Min.	Typ.	Max.		
UMTS TRX1 - TRX5 High Band (continued)					
TRX2 to RX1, RX2, RX3 1710-1880	30	37		dB	1710MHz to 1880MHz (continued)
TRX3 to RX1, RX2, RX3 1710-1880	35	42		dB	
TRX4 to RX1, RX2, RX3 1710-1880	35	41		dB	
TRX5 to RX1, RX2, RX3 1710-1880	35	41		dB	
TRX1 to TX1 1710-1880	50	56		dB	
TRX1 to TX2 1710-1880	27	33		dB	
TRX2 to TX1 1710-1880	50	58		dB	
TRX2 to TX2 1710-1880	27	33		dB	
TRX3 to TX1 1710-1880	55	60		dB	
TRX3 to TX2 1710-1880	30	36		dB	
TRX4 to TX1 1710-1880	55	60		dB	
TRX4 to TX2 1710-1880	30	36		dB	
TRX5 to TX1 1710-1880	55	60		dB	
TRX5 to TX2 1710-1880	27	35		dB	
TRX1 to TRX2 1850-1990	17	22		dB	1850MHz to 1990MHz
TRX1 to TRX3 1850-1990	30	41		dB	
TRX1 to TRX4 1850-1990	30	43		dB	
TRX1 to TRX5 1850-1990	30	39		dB	
TRX2 to TRX1 1850-1990	17	24		dB	
TRX2 to TRX3 1850-1990	30	40		dB	
TRX2 to TRX4 1850-1990	30	43		dB	
TRX2 to TRX5 1850-1990	30	39		dB	
TRX3 to TRX1 1850-1990	30	41		dB	
TRX3 to TRX2 1850-1990	30	48		dB	
TRX3 to TRX4 1850-1990	17	23		dB	
TRX3 to TRX5 1850-1990	25	34		dB	
TRX4 to TRX1 1850-1990	30	41		dB	
TRX4 to TRX2 1850-1990	30	53		dB	
TRX4 to TRX3 1850-1990	17	23		dB	
TRX4 to TRX5 1850-1990	17	24		dB	
TRX5 to TRX1 1850-1990	30	42		dB	
TRX5 to TRX2 1850-1990	30	52		dB	
TRX5 to TRX3 1850-1990	30	32		dB	
TRX5 to TRX4 1850-1990	17	24		dB	
TRX1 to RX1, RX2, RX3 1850-1990	20	31		dB	
TRX2 to RX1, RX2, RX3 1850-1990	30	36		dB	
TRX3 to RX1, RX2, RX3 1850-1990	35	41		dB	
TRX4 to RX1, RX2, RX3 1850-1990	35	41		dB	
TRX5 to RX1, RX2, RX3 1850-1990	35	40		dB	

Parameter	Specification			Unit	Condition
	Min.	Typ.	Max.		
UMTS TRX1 - TRX5 High Band (continued)					
TRX1 to TX1 1850-1990	50	55		dB	1850MHz to 1990MHz (continued)
TRX1 to TX2 1850-1990	27	33		dB	
TRX2 to TX1 1850-1990	50	56		dB	
TRX2 to TX2 1850-1990	28	33		dB	
TRX3 to TX1 1850-1990	50	56		dB	
TRX3 to TX2 1850-1990	27	32		dB	
TRX4 to TX1 1850-1990	50	56		dB	
TRX4 to TX2 1850-1990	27	31		dB	
TRX5 to TX1 1850-1990	50	55		dB	
TRX5 to TX2 1850-1990	27	31		dB	
TRX1 to TRX2 1920-2170	17	21		dB	1920MHz to 2170MHz
TRX1 to TRX3 1920-2170	30	40		dB	
TRX1 to TRX4 1920-2170	30	42		dB	
TRX1 to TRX5 1920-2170	30	37		dB	
TRX2 to TRX1 1920-2170	17	23		dB	
TRX2 to TRX3 1920-2170	30	38		dB	
TRX2 to TRX4 1920-2170	30	41		dB	
TRX2 to TRX5 1920-2170	30	37		dB	
TRX3 to TRX1 1920-2170	30	40		dB	
TRX3 to TRX2 1920-2170	30	53		dB	
TRX3 to TRX4 1920-2170	17	22		dB	
TRX3 to TRX5 1920-2170	25	33		dB	
TRX4 to TRX1 1920-2170	30	41		dB	
TRX4 to TRX2 1920-2170	30	50		dB	
TRX4 to TRX3 1920-2170	17	22		dB	
TRX4 to TRX5 1920-2170	17	24		dB	
TRX5 to TRX1 1920-2170	30	41		dB	
TRX5 to TRX2 1920-2170	30	48		dB	
TRX5 to TRX3 1920-2170	30	32		dB	
TRX5 to TRX4 1920-2170	17	23		dB	
TRX1 to RX1, RX2, RX3 1920-2170	22	31		dB	
TRX2 to RX1, RX2, RX3 1920-2170	30	35		dB	
TRX3 to RX1, RX2, RX3 1920-2170	35	40		dB	
TRX4 to RX1, RX2, RX3 1920-2170	35	40		dB	
TRX5 to RX1, RX2, RX3 1920-2170	35	40		dB	
TRX1 to TX1 1920-2170	50	54		dB	
TRX1 to TX2 1920-2170	28	33		dB	
TRX2 to TX1 1920-2170	50	55		dB	
TRX2 to TX2 1920-2170	28	33		dB	
TRX3 to TX1 1920-2170	50	54		dB	
TRX3 to TX2 1920-2170	28	32		dB	
TRX4 to TX1 1920-2170	50	54		dB	

Parameter	Specification			Unit	Condition
	Min.	Typ.	Max.		
UMTS TRX1 - TRX5 High Band (continued)					
TRX4 to TX2 1920-2170	28	32		dB	1920MHz to 2170MHz (continued)
TRX5 to TX1 1920-2170	47	53		dB	
TRX5 to TX2 1920-2170	27	31		dB	
TRX1 to TRX2 2300-2690	17	20		dB	2300MHz to 2690MHz
TRX1 to TRX3 2300-2690	30	37		dB	
TRX1 to TRX4 2300-2690	30	38		dB	
TRX1 to TRX5 2300-2690	30	33		dB	
TRX2 to TRX1 2300-2690	17	22		dB	
TRX2 to TRX3 2300-2690	30	35		dB	
TRX2 to TRX4 2300-2690	30	37		dB	
TRX2 to TRX5 2300-2690	30	33		dB	
TRX3 to TRX1 2300-2690	30	37		dB	
TRX3 to TRX2 2300-2690	30	51		dB	
TRX3 to TRX4 2300-2690	17	20		dB	
TRX3 to TRX5 2300-2690	25	29		dB	
TRX4 to TRX1 2300-2690	30	38		dB	
TRX4 to TRX2 2300-2690	30	47		dB	
TRX4 to TRX3 2300-2690	17	20		dB	
TRX4 to TRX5 2300-2690	17	21		dB	
TRX5 to TRX1 2300-2690	30	39		dB	
TRX5 to TRX2 2300-2690	30	45		dB	
TRX5 to TRX3 2300-2690	28	30		dB	
TRX5 to TRX4 2300-2690	17	21		dB	
TRX1 to RX1, RX2, RX3 2300-2690	21	29		dB	
TRX2 to RX1, RX2, RX3 2300-2690	28	33		dB	
TRX3 to RX1, RX2, RX3 2300-2690	33	38		dB	
TRX4 to RX1, RX2, RX3 2300-2690	33	38		dB	
TRX5 to RX1, RX2, RX3 2300-2690	33	38		dB	
TRX1 to TX1 2300-2690	53	58		dB	
TRX1 to TX2 2300-2690	33	39		dB	
TRX2 to TX1 2300-2690	55	60		dB	
TRX2 to TX2 2300-2690	33	39		dB	
TRX3 to TX1 2300-2690	53	58		dB	
TRX3 to TX2 2300-2690	33	38		dB	
TRX4 to TX1 2300-2690	53	58		dB	
TRX4 to TX2 2300-2690	33	38		dB	
TRX5 to TX1 2300-2690	52	57		dB	
TRX5 to TX2 2300-2690	33	37		dB	
Harmonics					
TRX - ANT, 2Fo	68	101		dBc	P _{IN} = 26dBm, CW
TRX - ANT, 3Fo	68	103		dBc	
TRX - ANT, up to 12.75GHz	68	104		dBc	

Parameter	Specification			Unit	Condition
	Min.	Typ.	Max.		
UMTS TRX1 - TRX5 High Band (continued)					
VSWR					
TRX1, 2, 3, 4, 5			1.40		1710MHz to 2170MHz
IIP2/IIP3 - C2K, UMTS					
IIP2 C2K Mode - Cell 824	113.5	128		dBm	Tone 1: 824MHz at 26dBm, Tone 2: 1693MHz at -20dBm Receive Freq: 869MHz
IIP2 C2K Mode - Cell 836	113.5	130		dBm	Tone 1: 836.5MHz at 26dBm, Tone 2: 1718MHz at -20dBm Receive Freq: 881.5MHz
IIP2 C2K Mode - Cell 849	113.5	128		dBm	Tone 1: 849MHz at 26dBm, Tone 2: 1743MHz at -20dBm Receive Freq: 894MHz
IIP2 C2K Mode - PCS 1850	95.5	128		dBm	Tone 1: 1850MHz at 26dBm, Tone 2: 3780MHz at -20dBm Receive Freq: 1930MHz
IIP2 C2K Mode - PCS 1880	95.5	129		dBm	Tone 1: 1880MHz at 26dBm, Tone 2: 3840MHz at -20dBm Receive Freq: 1960MHz
IIP2 C2K Mode - PCS 1910	95.5	127		dBm	Tone 1: 1910MHz at 26dBm, Tone 2: 3900MHz at -20dBm Receive Freq: 1990MHz
IIP2 C2K Mode - AWS 1710	95.5	127		dBm	Tone 1: 1710MHz at 26dBm, Tone 2: 3820MHz at -20dBm Receive Freq: 2110MHz
IIP2 C2K Mode - AWS 1732.5	95.5	126		dBm	Tone 1: 1732.5MHz at 26dBm, Tone 2: 3865MHz at -20dBm Receive Freq: 2132.5MHz
IIP2 C2K Mode - AWS 1755	95.5	126		dBm	Tone 1: 1755MHz at 26dBm, Tone 2: 3910MHz at -20dBm Receive Freq: 2155MHz
IIP2 UMTS Mode - 2600	102	112		dBm	Tone 1: 2535MHz at 20dBm, Tone 2: 120MHz at -15dBm Receive Freq: 2655MHz
IIP2 UMTS Mode - IMT	102	118		dBm	Tone 1: 1950MHz at 20dBm, Tone 2: 190MHz at -15dBm Receive Freq: 2140MHz
IIP2 UMTS Mode - PCS	102	112		dBm	Tone 1: 1880MHz at 20dBm, Tone 2: 80MHz at -15dBm Receive Freq: 1960MHz
IIP2 UMTS Mode - DCS	102	114		dBm	Tone 1: 1747MHz at 20dBm, Tone 2: 95MHz at -15dBm Receive Freq: 1842MHz
IIP2 UMTS Mode - PDC	102	107		dBm	Tone 1: 1440MHz at 20dBm, Tone 2: 48MHz at -15dBm Receive Freq: 1488MHz
IIP2 UMTS Mode - 900	102	109		dBm	Tone 1: 897MHz at 20dBm, Tone 2: 45MHz at -15dBm Receive Freq: 942MHz
IIP2 UMTS Mode - US cell	102	111		dBm	Tone 1: 836.5MHz at 20dBm, Tone 2: 45MHz at -15dBm Receive Freq: 881.5MHz
IIP3 UMTS Mode - 2600	61	76		dBm	Tone 1: 2535MHz at 20dBm, Tone 2: 2415MHz at -15dBm Receive Freq: 2655MHz

Parameter	Specification			Unit	Condition
	Min.	Typ.	Max.		
IIP2/IIP3 - C2K, UMTS (continued)					
IIP3 UMTS Mode - IMT	61	72		dBm	Tone 1: 1950MHz at 20dBm, Tone 2: 1760MHz at -15dBm Receive Freq: 2140MHz
IIP3 UMTS Mode - PCS	61	71		dBm	Tone 1: 1880MHz at 20dBm, Tone 2: 1800MHz at -15dBm Receive Freq: 1960MHz
IIP3 UMTS Mode - DCS	61	73		dBm	Tone 1: 1747MHz at 20dBm, Tone 2: 1652MHz at -15dBm Receive Freq: 1840MHz
IIP3 UMTS Mode - PDC	61	74		dBm	Tone 1: 1440MHz at 20dBm, Tone 2: 1392MHz at -15dBm Receive Freq: 1488MHz
IIP3 UMTS Mode - 900	61	80		dBm	Tone 1: 897MHz at 20dBm, Tone 2: 852MHz at -15dBm Receive Freq: 942MHz
IIP3 UMTS Mode - US cell	61	74		dBm	Tone 1: 836.5MHz at 20dBm, Tone 2: 791.5MHz at -15dBm Receive Freq: 881.5MHz
Triple Beat Ratio (TBR)					Nominal conditions unless otherwise stated. $V_{DD} = 2.75\text{ V}$, $V_{HIGH}/V_{LOW} = 1.8\text{ V}/0\text{ V}$, Temp = 25 °C, 50Ω.
TRX1 Triple Beat Ratio BC0 (GSM800)	81	89		dBc	VSWR=2:1; Temp=15, 25, 60 °C
TRX1 Triple Beat Ratio BC1 (PCS)	81	89		dBc	
TRX1 Triple Beat Ratio BC4	81	91		dBc	
TRX1 Triple Beat Ratio BC5 (GSM400)	81	91		dBc	
TRX1 Triple Beat Ratio BC14 (PCS)	81	89		dBc	
TRX1 Triple Beat Ratio BC15 (AWS)	81	102		dBc	
TRX2 Triple Beat Ratio BC0 (GSM800)	81	89		dBc	
TRX2 Triple Beat Ratio BC1 (PCS)	81	89		dBc	
TRX2 Triple Beat Ratio BC4	81	90		dBc	
TRX2 Triple Beat Ratio BC5 (GSM400)	81	91		dBc	
TRX2 Triple Beat Ratio BC14 (PCS)	81	89		dBc	
TRX2 Triple Beat Ratio BC15 (AWS)	81	101		dBc	
TRX3 Triple Beat Ratio BC0 (GSM800)	81	89		dBc	
TRX3 Triple Beat Ratio BC1 (PCS)	81	89		dBc	
TRX3 Triple Beat Ratio BC4	81	90		dBc	
TRX3 Triple Beat Ratio BC5 (GSM400)	81	91		dBc	
TRX3 Triple Beat Ratio BC14 (PCS)	81	89		dBc	
TRX3 Triple Beat Ratio BC15 (AWS)	81	101		dBc	
TRX4 Triple Beat Ratio BC0 (GSM800)	81	89		dBc	

Parameter	Specification			Unit	Condition
	Min.	Typ.	Max.		
Triple Beat Ratio (TBR) (continued)					
TRX4 Triple Beat Ratio BC1 (PCS)	81	89		dBc	VSWR=2:1; Temp=15, 25, 60 °C (continued)
TRX4 Triple Beat Ratio BC4	81	90		dBc	
TRX4 Triple Beat Ratio BC5 (GSM400)	81	91		dBc	
TRX4 Triple Beat Ratio BC14 (PCS)	81	89		dBc	
TRX4 Triple Beat Ratio BC15 (AWS)	81	101		dBc	
TRX5 Triple Beat Ratio BC0 (GSM800)	81	89		dBc	
TRX5 Triple Beat Ratio BC1 (PCS)	81	88		dBc	
TRX5 Triple Beat Ratio BC4	81	90		dBc	
TRX5 Triple Beat Ratio BC5 (GSM400)	81	90		dBc	
TRX5 Triple Beat Ratio BC14 (PCS)	81	88		dBc	
TRX5 Triple Beat Ratio BC15 (AWS)	81	101		dBc	
DC Control and Electrical Specifications					
V _{DD} Switch Supply Voltage	2.4		3.5	V	
V _{DD} Supply Current		0.10	0.15	mA	Active Mode
CTLA, CTLB, CTLC, CTLD - Control Voltage HIGH	1.3		2.7	V	
CTLA, CTLB, CTLC, CTLD - Control Voltage LOW	0		0.45	V	
Control Current			50	μA	
Switching Speed		3	5	μS	10% to 90% RF

TB GSM + PB UMTS				
Mode	V1	V2	V3	V4
ANT - GSM LB TX1	High	High	Low	Low
ANT - GSM HB TX2	High	Low	Low	Low
ANT - RX1	Low	Low	High	Low
ANT - RX2	Low	High	High	Low
ANT - RX3	Low	High	Low	Low
ANT - TRX1	High	Low	High	Low
ANT - TRX2	High	High	High	Low
ANT - TRX3	High	Low	High	High
ANT - TRX4	High	High	High	High
ANT - TRX5	High	Low	Low	High

Note: The SP10T switch is controlled by CTLA, CTLB, CTLC, and CTLD also referred to as V1, V2, V3 and V4 respectively.

Pin Out

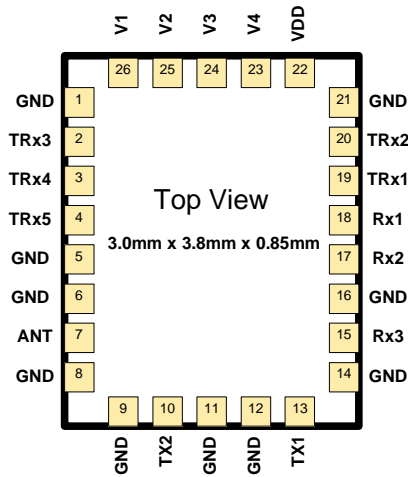

Pin	Function	Description
1	GND	Ground
2	TRX3	WCDMA RF Input/Output Port 3
3	TRX4	WCDMA RF Input/Output Port 4
4	TRX5	WCDMA RF Input/Output Port 5
5	GND	Ground
6	GND	Ground
7	ANT	Connected to Antenna
8	GND	Ground
9	GND	Ground
10	TX2	GSM 1800/1900 RF Transmit Input
11	GND	Ground
12	GND	Ground
13	TX1	GSM 850/900 RF Transmit Input
14	GND	Ground
15	RX3	GSM RF Output Port 3
16	GND	Ground
17	RX2	GSM RF Output Port 2
18	RX1	GSM RF Output Port 1
19	TRX1	WCDMA RF Input/Output Port 1
20	TRX2	WCDMA RF Input/Output Port 2
21	GND	Ground
22	VDD	Decoder and Charge Pump supply voltage (2.75V typical)
23	V4	RF Path Control 4 (CTLD) - Refer to Switch Control Table
24	V3	RF Path Control 3 (CTLC) - Refer to Switch Control Table
25	V2	RF Path Control 2 (CTLB) - Refer to Switch Control Table
26	V1	RF Path Control 1 (CTLA) - Refer to Switch Control Table

Package Drawing

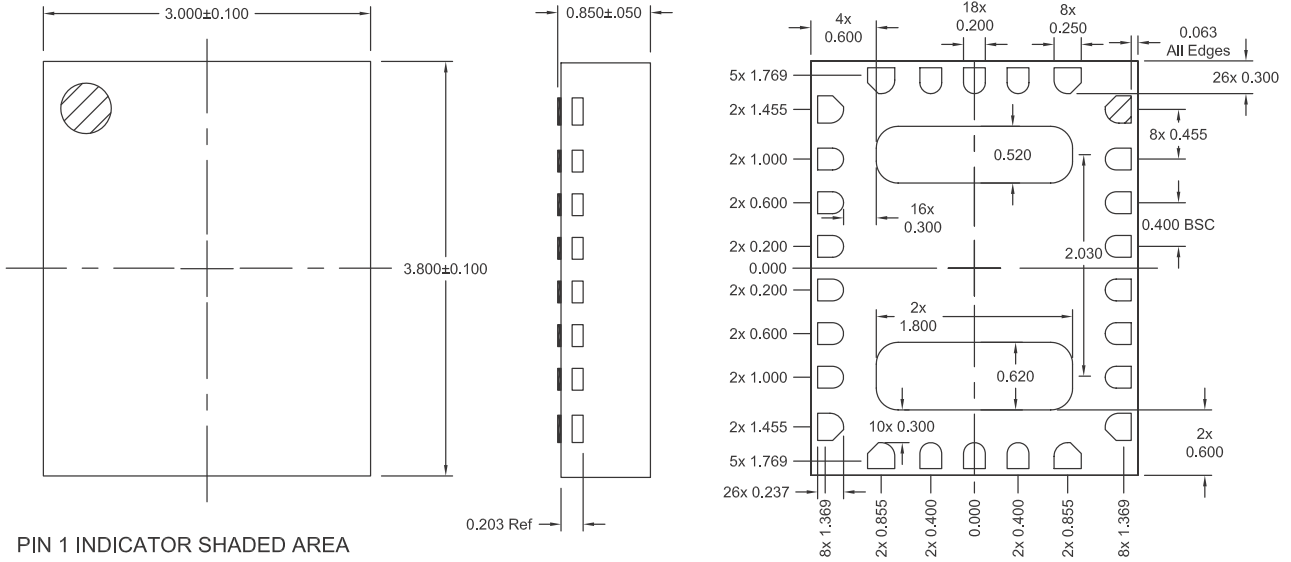

PIN 1 INDICATOR SHADED AREA

PCB Design Requirements

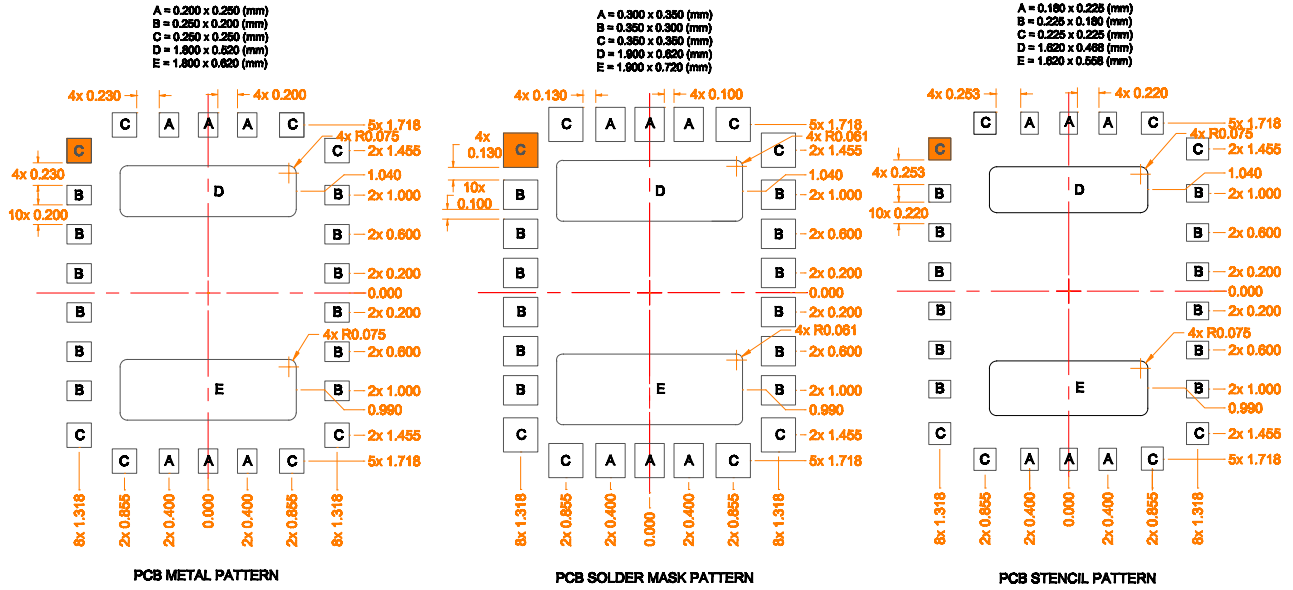

Evaluation Board Schematic

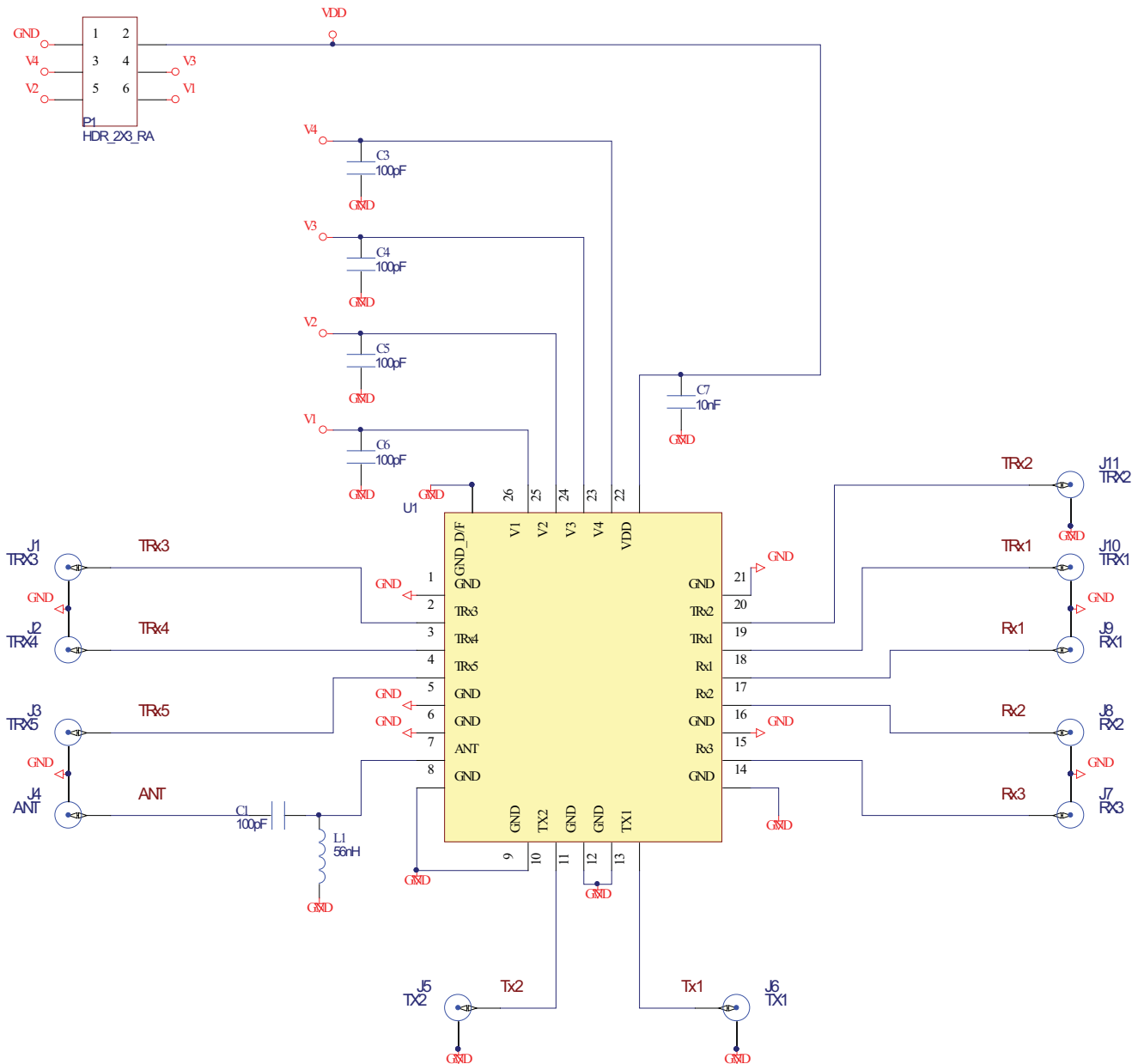

Application Environment

Decoupling capacitors on the control pins protect the control circuitry from possible RF leakage. As a good engineering practice, RF8889A evaluation board uses 100pF decoupling capacitors on the control lines, however these capacitors may require optimization based on the application. The use of these capacitors is routing dependent and in some applications, decoupling capacitors may not be required at all. A 10nF decoupling capacitor is recommended on the VDD line.

The value of L1 & C1 will depend on the Contact Discharge rating which needs to be achieved for a particular application. As contact discharge testing is very sensitive to grounding and proximity of the DUT to the antenna, it is difficult to specify contact

discharge rating based on evaluation board testing. Therefore, the values of these components on evaluation board have been optimized for best RF performance.

All RF paths on RF8889A are self-terminating, which means that any unused ports could either be left floating or be terminated to ground via capacitive coupling.

Electrical Test Methods

The electrical parameters for the switch are measured on test PWB provided by RFMD. The test PWB includes means for decoupling RF signals from control signal port (shunt capacitor at control signal ports). All measurements are done with calibration plane at switch pins. The effect of test board losses, and phase delay have been offset using the calibration board.

Evaluation Board Layout

Board Thickness 0.062", Board Material FR-4 and Rogers R04003

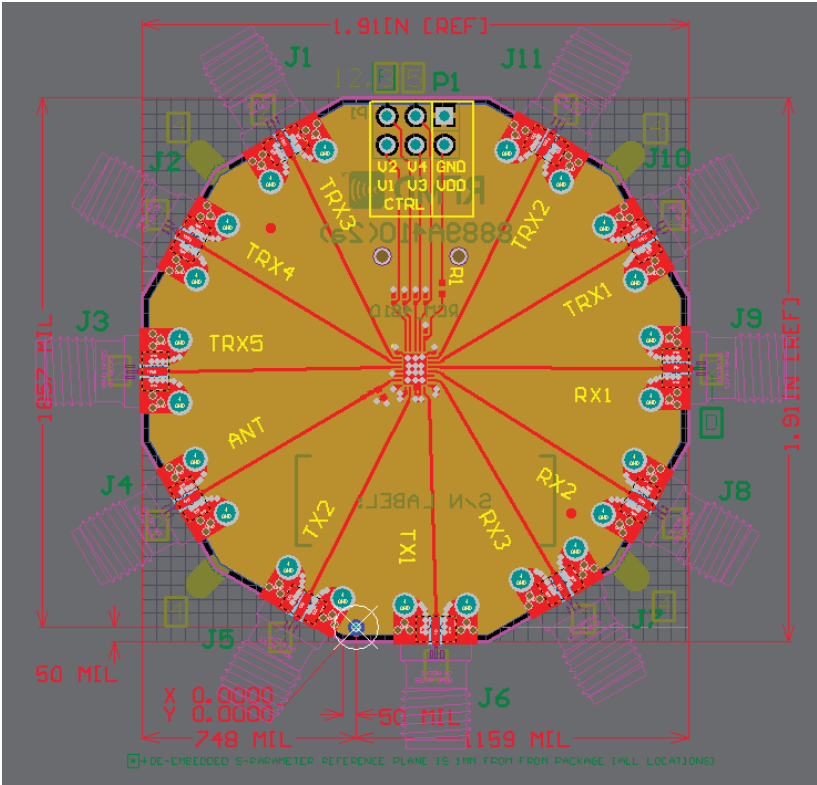

Layout Guidelines

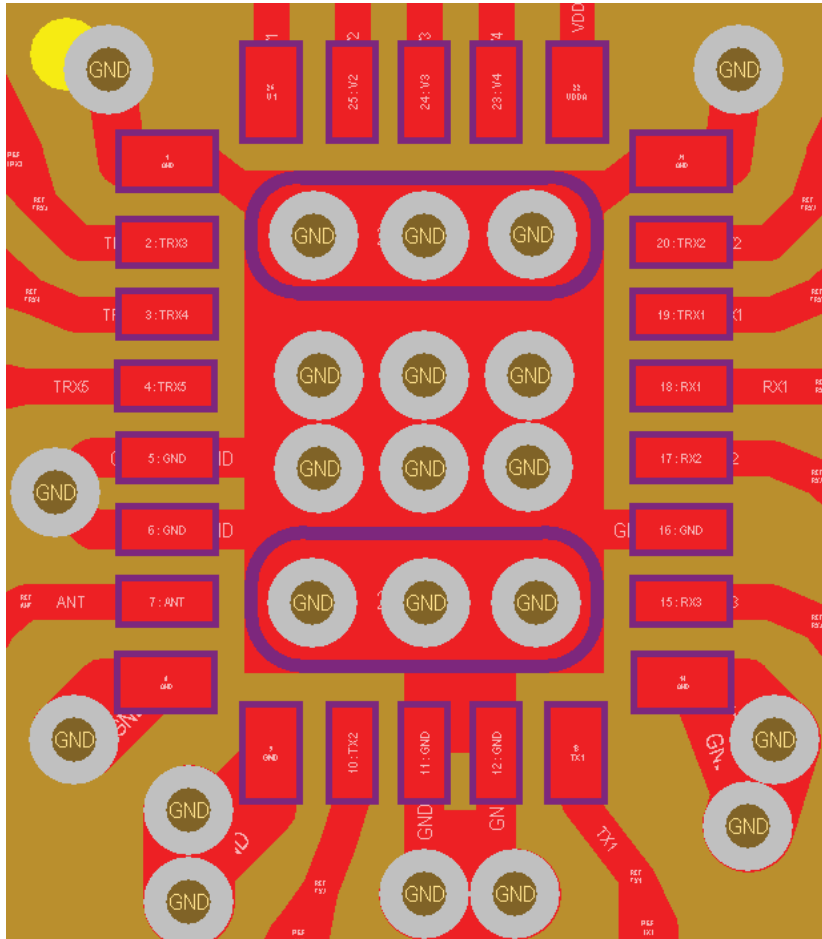

In order to get the best out of band attenuation as specified in the data sheet, layout guidelines should be followed as shown.

Theory of Operation

Product Description

The RF8889A is a SP10T Antenna Switch Module (ASM) with integrated dual low pass filters on GSM transmit paths optimized for best in class out of band attenuation and insertion loss. This simplifies the phone design by eliminating the need for discrete harmonic filters, and possible matching components. Integrated filtering provides ETSI compliant harmonic suppression at the antenna port even under mismatch conditions, which is important as modern antennas today often present a load that significantly deviates from nominal impedance.

The GSM RX ports of this module have symmetrical performance, and hence the Rx branches can be used interchangeably from 869MHz to 1990MHz which allows for ultimate user flexibility. This module also features an integrated charge-pump/decoder which allows for excellent linearity performance even at 1.3V GPIO. The decoder allows the switch to be controlled in any of the specified ten states as defined by the control logic using 4 general-purpose I/O control lines.

Typical Performance Data on Evaluation Board:

Fixture losses have been de-embedded (Temp=25 °C, V_{DD}=2.75 V, V_{CONTROL} High=1.8V, V_{CONTROL} Low=0V)

