



### Features

- Very Low Insertion Loss
- Best in Class Harmonic Attenuation with Integrated LPF: ETSI Compliance
- Exceptional Linearity Performance
- Lowest BOM Cost and Small Solution
- Symmetrical GSM Rx Ports Allow Ultimate Flexibility for Use With Any Transceiver
- Symmetrical UMTS Ports Allow Versatility for Use With Any Transceiver
- SP9T and SP8T Operation with No Loss in Performance
- GPIO Interface and Compatible with 1.8V Logic (VCTL-High Min = 1.3V)
- Small Footprint, 3.0mm x 3.8mm, 26-Pin QFN

### Applications

- Cellular Handset Applications
- Multi-Mode GSM, EDGE, WCDMA Applications
- GSM/GPRS/EDGE Switch Applications
- Cellular Infrastructure Applications

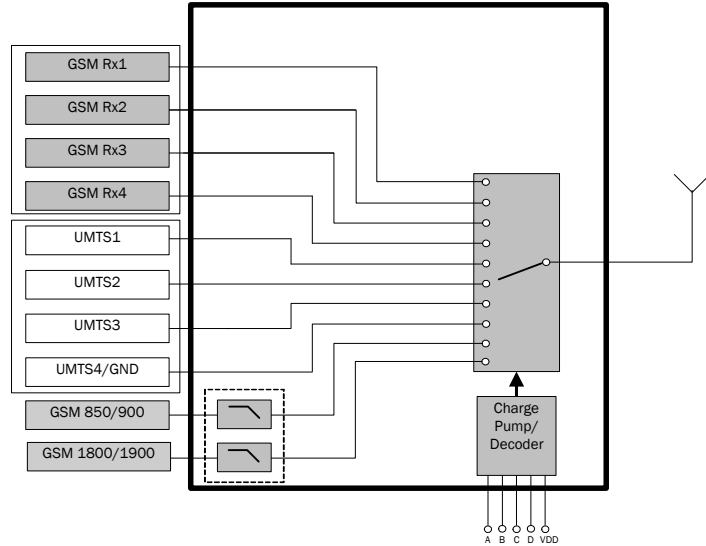

Functional Block Diagram

### Product Description

The RF1193A is a single-pole ten-throw (SP10T) Antenna Switch Module. Very Low insertion loss along with excellent linearity performance achieved by RF1193A makes it ideal for multi-mode GSM, EDGE, and UMTS handset applications. This module builds upon RFMD's pHEMT Switch technology and integrates low pass filtering on the GSM transmit paths thus avoiding the need for external harmonic attenuation. This module also integrates a decoder and is compatible with +1.8V control logic. RF1193A is packaged in a compact 3.0mm x 3.8mm x 0.85mm, 26-pin, QFN package which allows for a small solution size and lowest BOM cost as it does not require external DC blocking capacitors when external DC voltages are not applied to device ports.

### Ordering Information

RF1193A	SP10T Antenna Switch Module - Quadband GSM, Quadband UMTS
RF1193APCBA-410	Fully Assembled Evaluation Board

### Optimum Technology Matching® Applied

- |                                      |                                      |  |                                    |
|--------------------------------------|--------------------------------------|--|------------------------------------|
| <input type="checkbox"/> GaAs HBT    | <input type="checkbox"/> SiGe BiCMOS | <input checked="" type="checkbox"/> GaAs pHEMT | <input type="checkbox"/> GaN HEMT  |
| <input type="checkbox"/> GaAs MESFET | <input type="checkbox"/> Si BiCMOS   | <input checked="" type="checkbox"/> Si CMOS    | <input type="checkbox"/> BiFET HBT |
| <input type="checkbox"/> InGaP HBT   | <input type="checkbox"/> SiGe HBT    | <input type="checkbox"/> Si BJT                | <input type="checkbox"/> LD MOS    |

RF MICRO DEVICES®, RFMD®, Optimum Technology Matching®, Enabling Wireless Connectivity™, PowerStar®, POLARIS™ TOTAL RADIO™ and UltimateBlue™ are trademarks of RFMD, LLC. BLUETOOTH is a trademark owned by Bluetooth SIG, Inc., U.S.A. and licensed for use by RFMD. All other trade names, trademarks and registered trademarks are the property of their respective owners. ©2006, RF Micro Devices, Inc.

## Absolute Maximum Ratings

Parameter	Rating	Unit
VDD, CTLA, CTLB, CTLC, CTLD	6.0	V
Maximum Input Power		
TX1	+36, 12.5% (T <sub>AMB</sub> = 25 °C)	dBm
TRX1, TRX2, TRX3, TRX4	+32 (T <sub>AMB</sub> = 25 °C)	dBm
TX2	+34, 12.5% (T <sub>AMB</sub> = 25 °C)	dBm
RX1, RX2, RX3, RX4	+13 (T <sub>AMB</sub> = 25 °C)	dBm
Operating Temperature	-30 to +90	°C
Storage Temperature	-65 to +150	°C



**Caution!** ESD sensitive device.

Exceeding any one or a combination of the Absolute Maximum Rating conditions may cause permanent damage to the device. Extended application of Absolute Maximum Rating conditions to the device may reduce device reliability. Specified typical performance or functional operation of the device under Absolute Maximum Rating conditions is not implied.

The information in this publication is believed to be accurate and reliable. However, no responsibility is assumed by RF Micro Devices, Inc. ("RFMD") for its use, nor for any infringement of patents, or other rights of third parties, resulting from its use. No license is granted by implication or otherwise under any patent or patent rights of RFMD. RFMD reserves the right to change component circuitry, recommended application circuitry and specifications at any time without prior notice.



RFMD Green: RoHS compliant per EU Directive 2002/95/EC, halogen free per IEC 61249-2-21, < 1000ppm each of antimony trioxide in polymeric materials and red phosphorus as a flame retardant, and <2% antimony in solder.

Parameter	Specification			Unit	Condition
	Min.	Typ.	Max.		
					Nominal conditions unless otherwise stated. V <sub>DD</sub> = 2.65V, V <sub>HIGH</sub> /V <sub>LOW</sub> = 1.8V/0V, Temp = 25 °C, 50Ω. Compliant with ETSI multi-slot profile 2.
<b>GSM850/900 Transmit</b>					
Frequency Range (GSM850)	824	836.5	849	MHz	
Frequency Range (GSM900)	880	897.5	915	MHz	
Insertion Loss					
TX1 - ANT		0.85	1.30	dB	P <sub>IN</sub> = 35dBm, 12.5% DC, 824MHz to 849MHz, 880MHz to 915MHz
Attenuation					
TX1 - ANT, 2f <sub>0</sub>	24	37		dB	P <sub>IN</sub> = 0dBm; Freq = 1648MHz to 1830MHz
TX1 - ANT, 3f <sub>0</sub>	22	26		dB	P <sub>IN</sub> = 0dBm; Freq = 2472MHz to 2745MHz
TX1 - ANT, 4f <sub>0</sub>	30	37		dB	P <sub>IN</sub> = 0dBm; Freq = 3296MHz to 3660MHz
TX1 - ANT, 5f <sub>0</sub> up to 12.75GHz	18	21		dB	P <sub>IN</sub> = 0dBm; Freq = 4120MHz to 12750MHz
Isolation					
TX1 - RX1	35	44		dB	TX1 = 824MHz to 849MHz, 880MHz to 915MHz
TX1 - RX2	35	44		dB	
TX1 - RX3	35	44		dB	
TX1 - RX4	35	44		dB	
TX1 - TRX1	35	40		dB	
TX1 - TRX2	35	40		dB	
TX1 - TRX3	35	42		dB	
TX1 - TRX4	35	41		dB	
TX1 - TX2	25	31		dB	TX1 = 824MHz to 849MHz, 1648MHz to 1830MHz
TX2 - ANT	25	43		dB	TX2 = 1710MHz to 1910MHz

Parameter	Specification			Unit	Condition
	Min.	Typ.	Max.		
<b>GSM850/900 Transmit (continued)</b>					
Harmonics					
TX1 - ANT, $2f_0$	70	76		dBc	$P_{IN} = 35\text{dBm}$ , 12.5%DC
TX1 - ANT, $3f_0$	70	75		dBc	
TX1 - ANT, $4f_0 - 12.75\text{GHz}$	70	95		dBc	
VSWR			1.4		
<b>GSM1800/1900 Transmit</b>					
Frequency Range (GSM1800)	1710	1747.5	1785	MHz	
Frequency Range (GSM1900)	1850	1880	1910	MHz	
Insertion Loss					
TX2 - ANT		1.0	1.50	dB	$P_{IN} = 33\text{dBm}$ , 12.5% DC, 1710MHz to 1785MHz, 1850MHz to 1910MHz
Attenuation					
TX2 - ANT, $2f_0$	25	36		dB	$P_{IN} = 0\text{dBm}$ ; Freq = 3420MHz to 3820MHz
TX2 - ANT, $3f_0$	22	27		dB	$P_{IN} = 0\text{dBm}$ ; Freq = 5130MHz to 5730MHz
TX2 - ANT, $4f_0$ up to 12.75GHz	20	28		dB	$P_{IN} = 0\text{dBm}$ ; Freq = 6840MHz to 12750MHz
Isolation					
TX2 - RX1	30	36		dB	TX2 = 1710MHz to 1785MHz, 1850MHz to 1910MHz
TX2 - RX2	30	36		dB	
TX2 - RX3	30	36		dB	
TX2 - RX4	30	38		dB	
TX2 - TRX1	28	31		dB	
TX2 - TRX2	28	31		dB	
TX2 - TRX3	27	31		dB	
TX2 - TRX4	26	30		dB	
TX2 - TX1	36	46		dB	
TX1 - ANT	30	43		dB	
Harmonics					
TX2 - ANT, $2f_0$	68	80		dBc	$P_{IN} = 33\text{dBm}$ , 12.5%DC
TX2 - ANT, $3f_0$	68	75		dBc	
TX2 - ANT, up to 12.75GHz	68	95		dBc	
VSWR			1.4		

Parameter	Specification			Unit	Condition
	Min.	Typ.	Max.		
<b>GSM RX1, RX2, RX3, RX4</b>					
Frequency Range	869		960	MHz	
Frequency Range	1805		1990	MHz	
Insertion Loss					
RX1, RX2, RX3, RX4		0.65	0.80	dB	869MHz to 960MHz
		1.1	1.50	dB	1805MHz to 1990MHz
VSWR (ANT and RX)			1.6		
<b>UMTS 1, 2, 3, 4 - Low Band</b>					
Frequency Range	824		960	MHz	
Insertion Loss					
UMTS 1 - ANT		0.40	0.65	dB	
UMTS 2 - ANT		0.40	0.65	dB	
UMTS 3 - ANT		0.40	0.65	dB	
UMTS 4 - ANT		0.40	0.65	dB	
Isolation					
TRX1 - RX1	25	29		dB	824MHz to 915MHz
TRX1 - RX2	33	36		dB	
TRX1 - RX3	38	42		dB	
TRX1 - RX4	43	47		dB	
TRX2 - RX1, RX2, RX3, RX4	40	46		dB	825MHz to 915MHz
TRX3 - RX1, RX2, RX3, RX4	30	37		dB	
TRX4 - RX1, RX2, RX3, RX4	30	37		dB	
TRX1 - TX1	35	40		dB	
TRX1 - TX2	27	34		dB	
TRX1 - TRX2, TRX3, TRX4	25	31		dB	
TRX2 - TX1	35	38		dB	
TRX2 - TX2	30	35		dB	
TRX2 - TRX1, TRX3, TRX4	30	39		dB	
TRX3 - TX1	35	38		dB	
TRX3 - TX2	32	36		dB	
TRX3 - TRX1, TRX2	28	31		dB	
TRX3 - TRX4	17	23		sB	
TRX4 - TX1	35	40		dB	
TRX4 - TX2	35	41		dB	
TRX4 - TRX1, TRX2, TRX3	27	36		dB	
Harmonics					
UMTS 1, 2, 3, 4 - ANT, 2f <sub>0</sub>	62	100		dBc	P <sub>IN</sub> = 26dBm, CW
UMTS 1, 2, 3, 4 - ANT, 3f <sub>0</sub>	62	88		dBc	
UMTS 1, 2, 3, 4 - ANT, up to 12.75GHz	62	102		dBc	

Parameter	Specification			Unit	Condition
	Min.	Typ.	Max.		
<b>UMTS 1, 2, 3, 4 - Low Band (continued)</b>					
<b>IMD2</b>					
TRX1 - ANT		-117	-105	dBm	Tone 1: 836.5MHz at 20dBm Tone 2: 45MHz at -15dBm Receive Freq: 881.5MHz
		-114	-105	dBm	Tone 1: 836.5MHz at 20dBm Tone 2: 1718MHz at -15dBm Receive Freq: 881.5MHz
TRX2 - ANT		-111	-105	dBm	Tone 1: 836.5MHz at 20dBm Tone 2: 45MHz at -15dBm Receive Freq: 881.5MHz
		-110	-105	dBm	Tone 1: 836.5MHz at 20dBm Tone 2: 1718MHz at -15dBm Receive Freq: 881.5MHz
TRX3 - ANT		-112	-105	dBm	Tone 1: 836.5MHz at 20dBm Tone 2: 45MHz at -15dBm Receive Freq: 881.5MHz
		-111	-105	dBm	Tone 1: 836.5MHz at 20dBm Tone 2: 1718MHz at -15dBm Receive Freq: 881.5MHz
TRX4 - ANT		-110	-105	dBm	Tone 1: 836.5MHz at 20dBm Tone 2: 45MHz at -15dBm Receive Freq: 881.5MHz
		-112	-105	dBm	Tone 1: 836.5MHz at 20dBm Tone 2: 1718MHz at -15dBm Receive Freq: 881.5MHz
<b>IMD3</b>					
TRX1 - ANT		-115	-105	dBm	Tone 1: 836.5MHz at 20dBm Tone 2: 791.5MHz at -15dBm Receive Freq: 881.5MHz
		-114	-105	dBm	Tone 1: 836.5MHz at 20dBm Tone 2: 2554.5MHz at -15dBm Receive Freq: 881.5MHz
TRX2 - ANT		-113	-105	dBm	Tone 1: 836.5MHz at 20dBm Tone 2: 791.5MHz at -15dBm Receive Freq: 881.5MHz
		-110	-105	dBm	Tone 1: 836.5MHz at 20dBm Tone 2: 2554.5MHz at -15dBm Receive Freq: 881.5MHz
TRX3 - ANT		-113	-105	dBm	Tone 1: 836.5MHz at 20dBm Tone 2: 791.5MHz at -15dBm Receive Freq: 881.5MHz
		-110	-105	dBm	Tone 1: 836.5MHz at 20dBm Tone 2: 2554.5MHz at -15dBm Receive Freq: 881.5MHz
TRX4 - ANT		-113	-105	dBm	Tone 1: 836.5MHz at 20dBm Tone 2: 791.5MHz at -15dBm Receive Freq: 881.5MHz
		-111	-105	dBm	Tone 1: 836.5MHz at 20dBm Tone 2: 2554.5MHz at -15dBm Receive Freq: 881.5MHz
VSWR			1.4		

Parameter	Specification			Unit	Condition
	Min.	Typ.	Max.		
<b>UMTS 1, 2, 3, 4 - High Band</b>					
Frequency Range	1710		1910	MHz	
Frequency Range	1910		2170	MHz	
Insertion Loss					
UMTS 1 - ANT		0.65	0.90	dB	P <sub>IN</sub> = 26dB, CW, 1710MHz to 1910MHz
UMTS 2 - ANT		0.65	0.80	dB	
UMTS 3 - ANT		0.65	0.85	dB	
UMTS 4 - ANT		0.75	0.90	dB	
UMTS 1 - ANT		0.70	1.10	dB	P <sub>IN</sub> = 26dB, CW, 1910MHz to 1980MHz
UMTS 2 - ANT		0.65	1.00	dB	
UMTS 3 - ANT		0.70	1.00	dB	
UMTS 4 - ANT		0.75	1.00	dB	
UMTS 1 - ANT		0.75	1.10	dB	P <sub>IN</sub> = 26dB, CW, 2110MHz to 2170MHz
UMTS 2 - ANT		0.70	0.90	dB	
UMTS 3 - ANT		0.75	0.95	dB	
UMTS 4 - ANT		0.85	1.00	dB	
Isolation					
TRX1 - RX1	19	22		dB	1710MHz to 1910MHz, 1910MHz to 1980MHz
TRX1 - RX2	25	29		dB	
TRX1 - RX3	30	34		dB	
TRX1 - RX4	35	39		dB	
TRX2 - RX1, RX2, RX3, RX4	30	36		dB	
TRX3 - RX1, RX2, RX3, RX4	30	36		dB	
TRX4 - RX1, RX2, RX3, RX4	30	36		dB	
TRX1 - TX1	50	55		dB	
TRX1 - TX2	24	28		dB	
TRX1 - TRX2, TRX3, TRX4	29	31		dB	
TRX2 - TX1	50	59		dB	
TRX2 - TX2	25	30		dB	
TRX2 - TRX1, TRX3, TRX4	25	30		dB	
TRX3 - TX1	50	58		dB	
TRX3 - TX2	27	31		dB	
TRX3 - TRX1, TRX2	27	30		dB	
TRX3 - TRX4	20	23		dB	

Parameter	Specification			Unit	Condition
	Min.	Typ.	Max.		
<b>UMTS 1, 2, 3, 4 - High Band (continued)</b>					
Isolation (continued)					
TRX4 - TX1	50	58		dB	1710MHz to 1910MHz, 1910MHz to 1980MHz
TRX4 - TX2	30	35		dB	
TRX4 - TRX1, TRX2	25	31		dB	1710MHz to 1910MHz
TRX4 - TRX3	19	21		dB	
TRX4 - TRX1	27	30		dB	1910MHz to 1980MHz
TRX4 - TRX2	27	30		dB	
TRX4 - TRX3	18	21		dB	
Harmonics					
UMTS 1, 2, 3, 4 - ANT, 2f <sub>0</sub>	62	94		dBc	P <sub>IN</sub> = 26dBm, CW
UMTS 1, 2, 3, 4 - ANT, 3f <sub>0</sub>	62	84		dBc	
UMTS 1, 2, 3, 4 - ANT, up to 12.75GHz	62	100		dBc	
IMD2					
TRX1 - ANT		-115	-105	dBm	Tone 1: 1880MHz at 20dBm Tone 2: 80MHz at -15dBm Receive Freq: 1960MHz
		-111	-105	dBm	Tone 1: 1880MHz at 20dBm Tone 2: 3840MHz at -15dBm Receive Freq: 1960MHz
		-114	-105	dBm	Tone 1: 1950MHz at 20dBm Tone 2: 190MHz at -15dBm Receive Freq: 2140MHz
		-111	-105	dBm	Tone 1: 1950MHz at 20dBm Tone 2: 4090MHz at -15dBm Receive Freq: 2140MHz
TRX2 - ANT		-107	-105	dBm	Tone 1: 1880MHz at 20dBm Tone 2: 80MHz at -15dBm Receive Freq: 1960MHz
		-108	-105	dBm	Tone 1: 1880MHz at 20dBm Tone 2: 3840MHz at -15dBm Receive Freq: 1960MHz
		-114	-105	dBm	Tone 1: 1950MHz at 20dBm Tone 2: 190MHz at -15dBm Receive Freq: 2140MHz
		-109	-105	dBm	Tone 1: 1950MHz at 20dBm Tone 2: 4090MHz at -15dBm Receive Freq: 2140MHz
TRX3 - ANT		-110	-105	dBm	Tone 1: 1880MHz at 20dBm Tone 2: 80MHz at -15dBm Receive Freq: 1960MHz
		-108	-105	dBm	Tone 1: 1880MHz at 20dBm Tone 2: 3840MHz at -15dBm Receive Freq: 1960MHz
		-113	-105	dBm	Tone 1: 1950MHz at 20dBm Tone 2: 190MHz at -15dBm Receive Freq: 2140MHz
		-108	-105	dBm	Tone 1: 1950MHz at 20dBm Tone 2: 4090MHz at -15dBm Receive Freq: 2140MHz

Parameter	Specification			Unit	Condition
	Min.	Typ.	Max.		
<b>UMTS 1, 2, 3, 4 - High Band (continued)</b>					
IMD2 (continued)					
TRX4 - ANT		-107	-105	dBm	Tone 1: 1880MHz at 20dBm Tone 2: 80MHz at -15dBm Receive Freq: 1960MHz
		-108	-105	dBm	Tone 1: 1880MHz at 20dBm Tone 2: 3840MHz at -15dBm Receive Freq: 1960MHz
		-114	-105	dBm	Tone 1: 1950MHz at 20dBm Tone 2: 190MHz at -15dBm Receive Freq: 2140MHz
		-110	-105	dBm	Tone 1: 1950MHz at 20dBm Tone 2: 4090MHz at -15dBm Receive Freq: 2140MHz
IMD3					
TRX1 - ANT		-119	-105	dBm	Tone 1: 1880MHz at 20dBm Tone 2: 1800MHz at -15dBm Receive Freq: 1960MHz
		-112	-105	dBm	Tone 1: 1880MHz at 20dBm Tone 2: 5720MHz at -15dBm Receive Freq: 1960MHz
		-115	-105	dBm	Tone 1: 1950MHz at 20dBm Tone 2: 1760MHz at -15dBm Receive Freq: 2140MHz
		-114	-105	dBm	Tone 1: 1950MHz at 20dBm Tone 2: 6040MHz at -15dBm Receive Freq: 2140MHz
TRX2 - ANT		-112	-105	dBm	Tone 1: 1880MHz at 20dBm Tone 2: 1800MHz at -15dBm Receive Freq: 1960MHz
		-107	-105	dBm	Tone 1: 1880MHz at 20dBm Tone 2: 5720MHz at -15dBm Receive Freq: 1960MHz
		-114	-105	dBm	Tone 1: 1950MHz at 20dBm Tone 2: 1760MHz at -15dBm Receive Freq: 2140MHz
		-110	-105	dBm	Tone 1: 1950MHz at 20dBm Tone 2: 6040MHz at -15dBm Receive Freq: 2140MHz
TRX3 - ANT		-112	-105	dBm	Tone 1: 1880MHz at 20dBm Tone 2: 1800MHz at -15dBm Receive Freq: 1960MHz
		-107	-105	dBm	Tone 1: 1880MHz at 20dBm Tone 2: 5720MHz at -15dBm Receive Freq: 1960MHz
		-115	-105	dBm	Tone 1: 1950MHz at 20dBm Tone 2: 1760MHz at -15dBm Receive Freq: 2140MHz
		-109	-105	dBm	Tone 1: 1950MHz at 20dBm Tone 2: 6040MHz at -15dBm Receive Freq: 2140MHz

Parameter	Specification			Unit	Condition
	Min.	Typ.	Max.		
<b>UMTS 1, 2, 3, 4 - High Band (continued)</b>					
IMD3 (continued)					
TRX4 - ANT		-111	-105	dBm	Tone 1: 1880MHz at 20dBm Tone 2: 1800MHz at -15dBm Receive Freq: 1960MHz
		-107	-105	dBm	Tone 1: 1880MHz at 20dBm Tone 2: 5720MHz at -15dBm Receive Freq: 1960MHz
		-115	-105	dBm	Tone 1: 1950MHz at 20dBm Tone 2: 1760MHz at -15dBm Receive Freq: 2140MHz
		-110	-105	dBm	Tone 1: 1950MHz at 20dBm Tone 2: 6040MHz at -15dBm Receive Freq: 2140MHz
VSWR			1.5		
<b>Triple Beat Ratio (TBR)</b>					
TRX1 Triple Beat Ratio					
BC0 (GSM800)	81	84		dBc	
BC1 (PCS)	81	82		dBc	
BC4	81	81		dBc	
BC5 (GSM400)	81	94		dBc	
BC14 (PCS)	81	82		dBc	
BC15 (AWS)	81	95		dBc	
TRX2 Triple Beat Ratio					
BC0 (GSM800)	81	82		dBc	
BC1 (PCS)	81	82		dBc	
BC4	81	82		dBc	
BC5 (GSM400)	81	85		dBc	
BC14 (PCS)	81	82		dBc	
BC15 (AWS)	81	93		dBc	
TRX3 Triple Beat Ratio					
BC0 (GSM800)	81	82		dBc	
BC1 (PCS)	81	82		dBc	
BC4	81	82		dBc	
BC5 (GSM400)	81	87		dBc	
BC14 (PCS)	81	82		dBc	
BC15 (AWS)	81	94		dBc	
TRX4 Triple Beat Ratio					
BC0 (GSM800)	81	82		dBc	
BC1 (PCS)	81	82		dBc	
BC4	81	82		dBc	
BC5 (GSM400)	81	85		dBc	
BC14 (PCS)	81	82		dBc	
BC15 (AWS)	81	92		dBc	

Parameter	Specification			Unit	Condition
	Min.	Typ.	Max.		
<b>DC Control and Electrical Specifications</b>					
V <sub>DD</sub> - Switch Supply Voltage	2.5	2.65	3.3	V	
V <sub>DD</sub> Supply Current		0.65	1.0	mA	Active Mode
VC1, VC2, VC3, VC4 - Control Voltage - VHIGH	1.3	1.8	3.0	V	
VC1, VC2, VC3, VC4 - Control Voltage - VLOW		0	0.3	V	
Control Current			1.5	uA	
Switching Speed		2	5	uS	90% OFF to 90% ON, 90% ON to 90% OFF

### Pin Names and Description

Pin	Name	Description
1	GND	Ground.
2	TRX2	WCDMA RF Input/Output Port 2.
3	GND	Ground.
4	TRX3	WCDMA RF Input/Output Port 3.
5	TRX4/GND	WCDMA RF Input/Output Port 4 (Ground for SP9T operation).
6	GND	Ground.
7	ANT	Connected to Antenna
8	GND	Ground.
9	GND	Ground.
10	TX2	GSM 1800/1900 RF Transmit Input.
11	GND	Ground.
12	GND	Ground.
13	TX1	GSM 800/900 RF Transmit Input
14	GND	Ground.
15	GND	Ground.
16	RX4	GSM RF Output Port 4.
17	RX3	GSM RF Output Port 3.
18	RX2	GSM RF Output Port 2.
19	RX1	GSM RF Output Port 1.
20	TRX1	WCDMA RF Input/Output Port 1.
21	GND	Ground.
22	VDD	Decoder and Charge Pump supply voltage (2.65 typical).
23	CTLD	RF Path control D (See Switch Control table).
24	CTL C	RF Path control C (See Switch Control table).
25	CTL B	RF Path control B (See Switch Control table).
26	CTL A	RF Path control A (See Switch Control table).
Pkg Base	GND	

## Pin Out

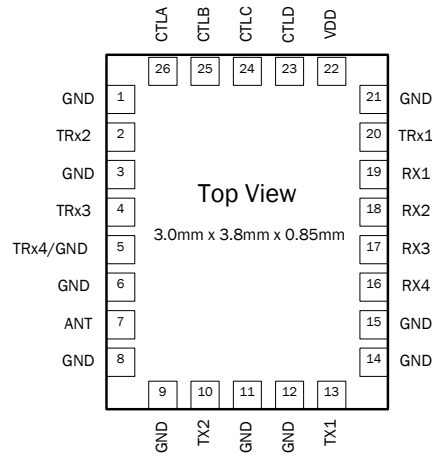

Note:  
 Pin 5  
 SP9T: Connect directly to GND  
 SP10T: TRx4

## Package Drawing

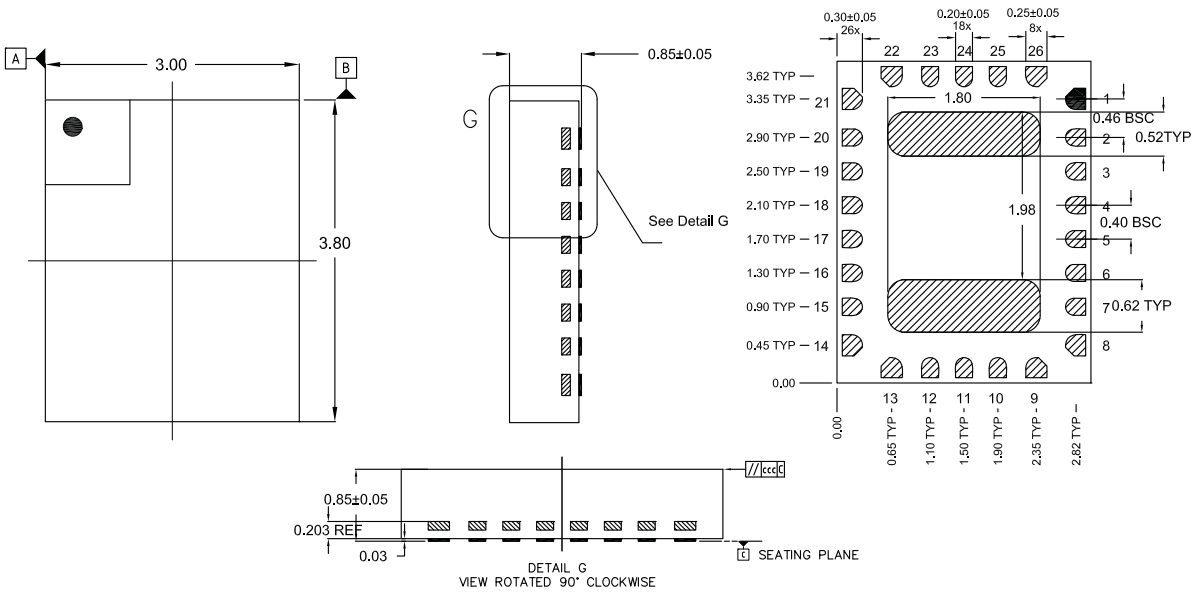

1) PIN 1 INDICATOR SHADED AREA  
 Notes:

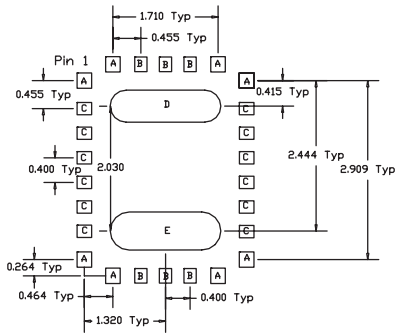

PCB METAL LAND PATTERN

- A = 0.237 x 0.250 (mm) Typ
- B = 0.200 x 0.237 (mm) Typ
- C = 0.237 x 0.200 (mm) Typ
- D = 1.800 x 0.520 (mm) Rounded rectangles with corner radius of 75%
- E = 1.800 x 0.620 (mm) Rounded rectangles with corner radius of 75%

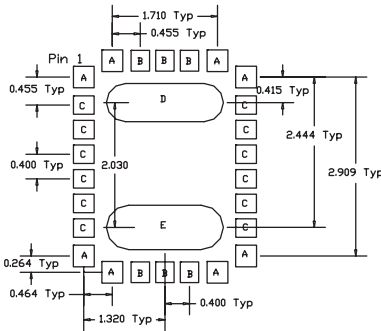

PCB SOLDER MASK PATTERN

- A = 0.337 x 0.350 (mm) Typ
- B = 0.300 x 0.337 (mm) Typ
- C = 0.337 x 0.300 (mm) Typ
- D = 1.900 x 0.620 (mm) Rounded rectangles with corner radius of 75%
- E = 1.900 x 0.720 (mm) Rounded rectangles with corner radius of 75%

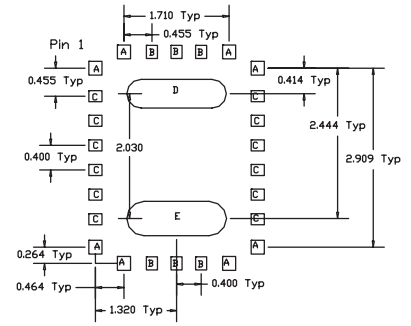

PCB STENCIL PATTERN

- A = 0.213 x 0.225 (mm) Typ
- B = 0.180 x 0.213 (mm) Typ
- C = 0.213 x 0.180 (mm) Typ
- D = 1.620 x 0.468 (mm) Rounded rectangles with corner radius of 75%
- E = 1.620 x 0.538 (mm) Rounded rectangles with corner radius of 75%

## General Information

### Control Logic

The SP10T switch is controlled by CTLA, CTLB, CTLC, and CTLD.

4 GSM+4 UMTS				
Switch Path	CTLA	CTLB	CTLC	CTLD
TX1-ANT	1	1	0	0
TX2-ANT	1	0	0	0
RX1-ANT*	0	0	0	0
RX2-ANT*	0	0	1	0
RX3-ANT*	0	1	1	0
RX4-ANT*	0	1	0	0
TRX1-ANT	1	0	1	0
TRX2-ANT	1	1	1	0
TRX3-ANT	1	0	1	1
TRX4-ANT	1	1	1	1

\*-RX1, RX2 RX3, and RX4 are symmetric and can be used interchangeably for GSM low-band and high-band.

Note: In SP9T mode, TRX4 can be used by terminating any other unused port to Ground.

## Evaluation Board Schematic

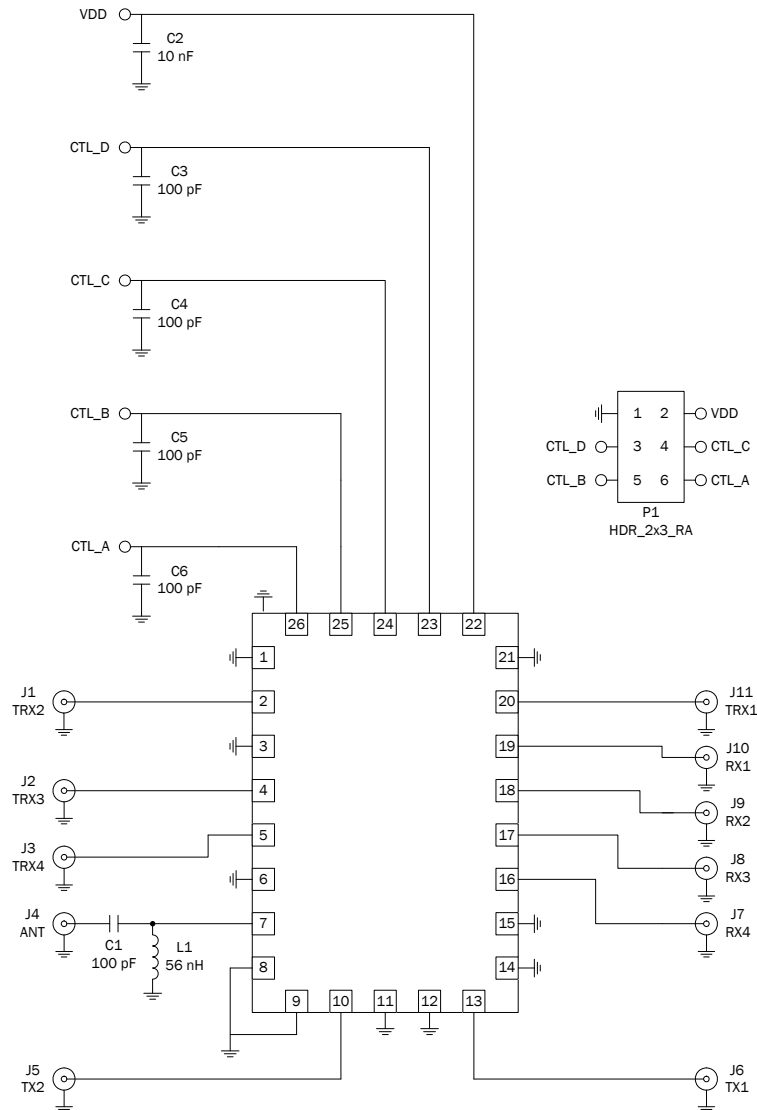

### Application Environment

The switch can be placed directly under, or in close vicinity to, the antenna. Shielding cans covering the switch are not required, and they can be in close vicinity to the PA. The switch can be mounted on a flexible PWB.

### Application Diagram and Guidelines

Decoupling capacitors on the control pins protect the control circuitry from possible RF leakage. A 100pF decoupling capacitor is recommended on the  $V_{DD}$  line. The value of L1 will depend on the Contact Discharge rating which needs to be achieved for the application.

In SP9T mode, TRX4 can be used by terminating any other unused port to Ground.

### Electrical Test Methods

The electrical parameters for the switch are measured on test PWB provided by RFMD. The test PWB includes means for decoupling RF signals from control signal port (shunt capacitor at control signal ports).

All measurements are done with calibration plane at switch pins. The effect of test board losses and phase delay are removed from the results by calibrating using the calibration board.

## Evaluation Board Layout Board Size 1.9" Diameter

Board Thickness 0.062", Board Material FR-4 and Rogers R04003

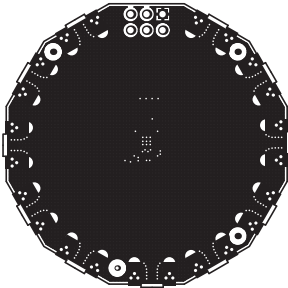
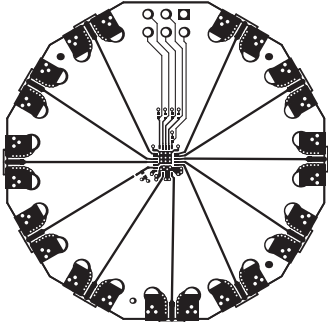
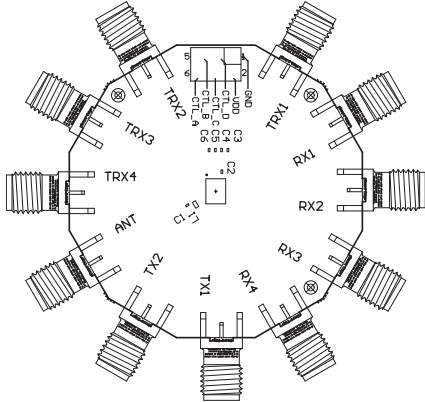

**Layout Guidelines**

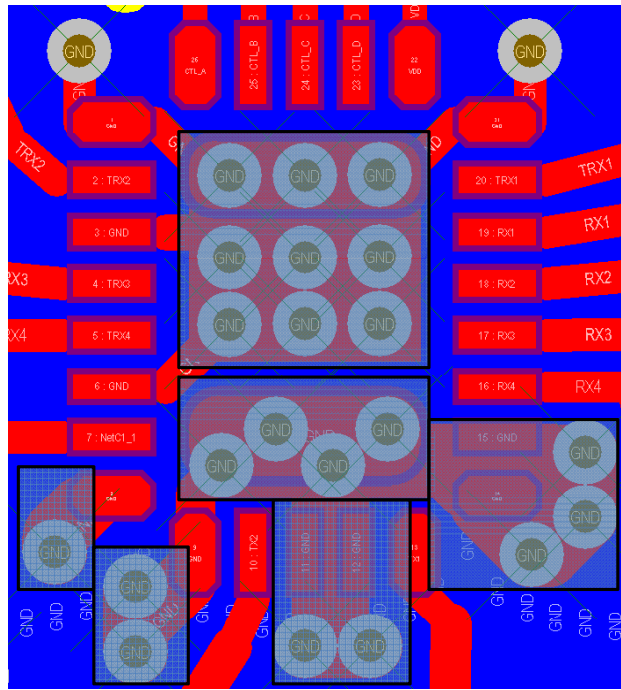

In order to get the best out of band attenuation as specified in the data sheet, layout guidelines should be followed as shown in the highlighted boxes.

## Theory of Operation

### Product Description

The RF1193A is a SP10T Switch Filter Module (SFM) with fully integrated dual Low Pass Filters on GSM Transmit paths and an integrated decoder/charge-pump. This simplifies the phone design by eliminating the need for discrete harmonic filters, switches and possible matching components. The GSM RX ports of this module have symmetrical performance and hence the Rx branches can be used interchangeably from 869MHz to 1990MHz which allows for ultimate user flexibility. Integrated filtering provides ETSI compliant harmonic suppression at the antenna port even under mismatch conditions, which is important as modern antennas today often present a load that significantly deviates from nominal impedance.

This module also features an integrated charge-pump/decoder which allows for excellent linearity performance even at 1.8V control voltage. The decoder allows the switch to be controlled in any of the specified ten states as defined by the control logic on page 14 using 4 general-purpose I/O control lines.

### Typical Performance Data on Evaluation Board:

Fixture losses have been de-embedded (Temp = 25°C,  $V_{DD} = 2.75V$ ,  $V_{CONTROL}$  High = 1.8V,  $V_{CONTROL}$  Low = 0V)

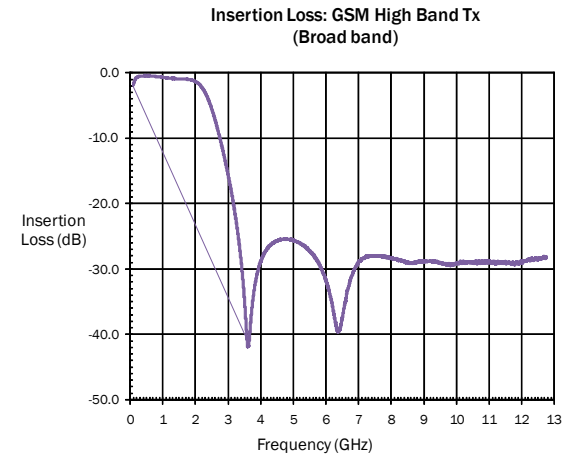
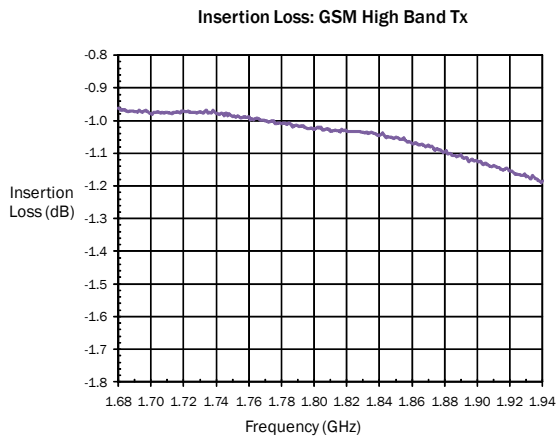
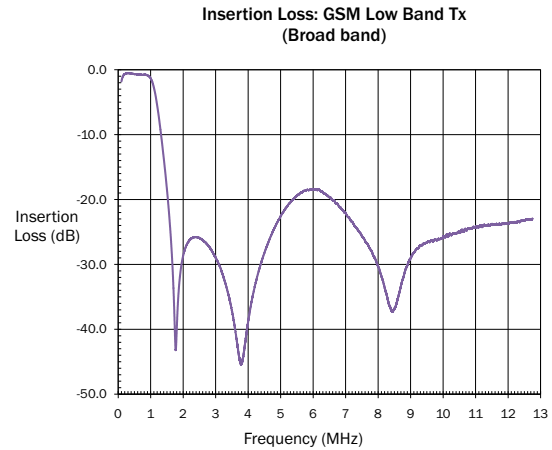
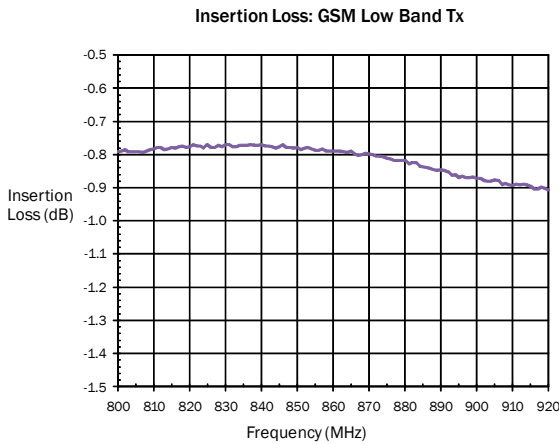

Typical Performance Data on Evaluation Board:

Fixture losses have been de-embedded (Temp = 25 °C,  $V_{DD} = 2.75V$ ,  $V_{CONTROL\ High} = 1.8V$ ,  $V_{CONTROL\ Low} = 0V$ )

Insertion Loss: TRX1 (Low Band)

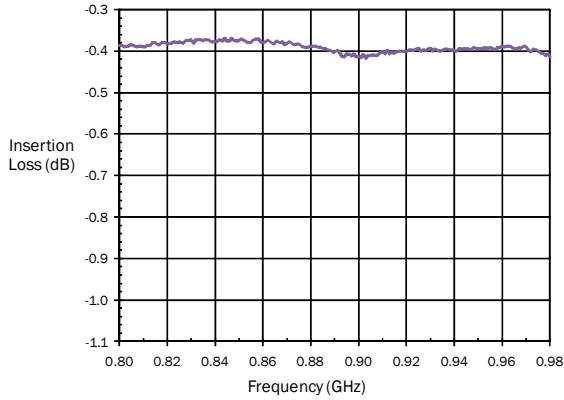

Insertion Loss: TRX1 (High Band)

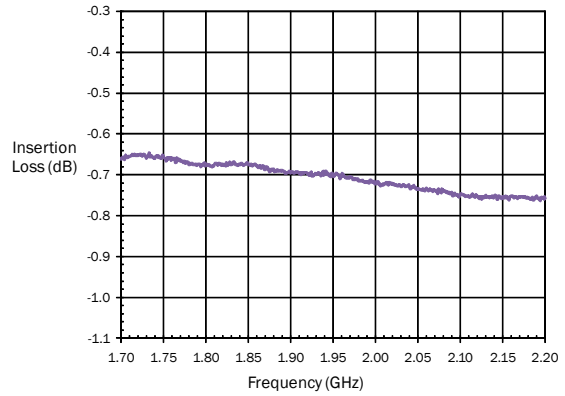

Insertion Loss: TRX2 (Low Band)

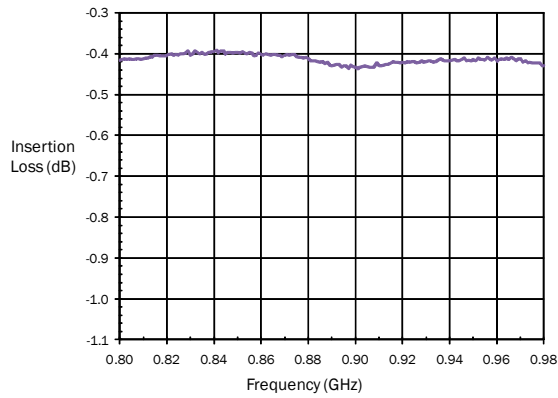

Insertion Loss: TRX2 (High Band)

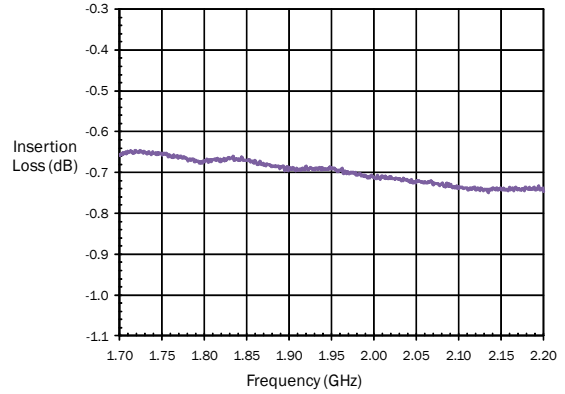

Insertion Loss: TRX3 (Low Band)

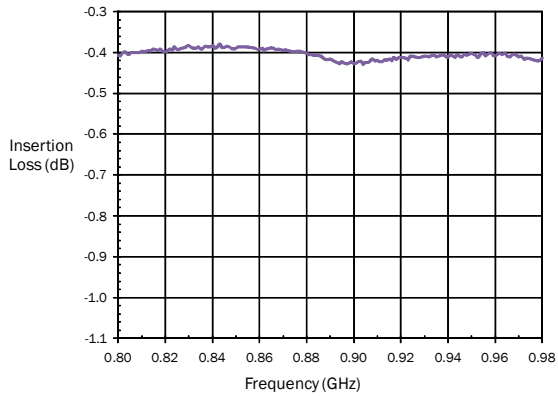

Insertion Loss: TRX3 (High Band)

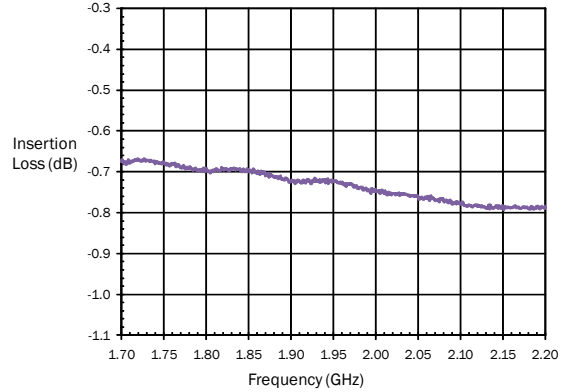

Typical Performance Data on Evaluation Board:

Fixture losses have been de-embedded (Temp = 25 °C,  $V_{DD} = 2.75V$ ,  $V_{CONTROL\ High} = 1.8V$ ,  $V_{CONTROL\ Low} = 0V$ )

Insertion Loss: TRX4 (Low Band)

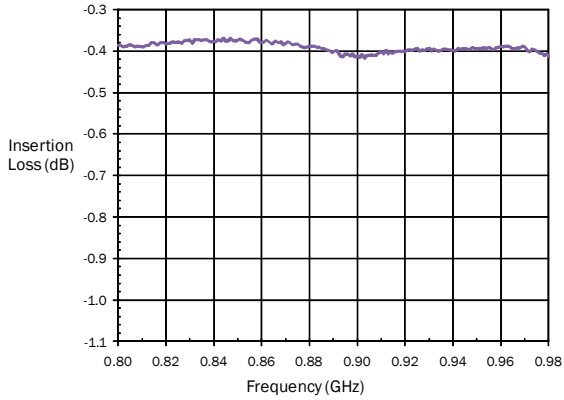

Insertion Loss: TRX4 (High Band)

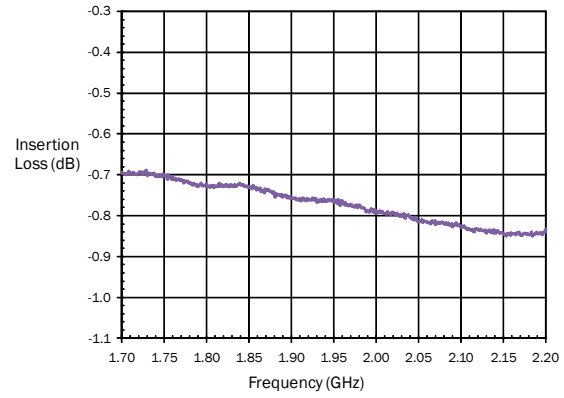

Insertion Loss: RX1, 2, 3, 4 (Low Band)

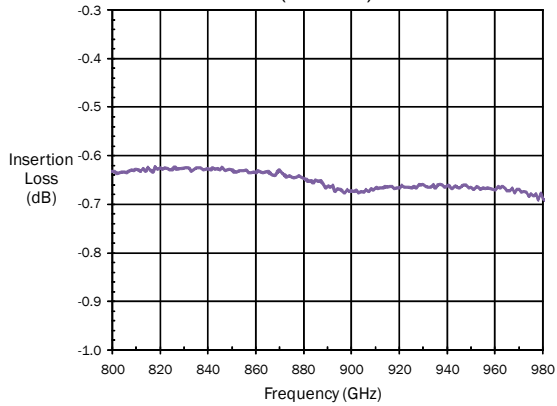

Insertion Loss: RX1, 2, 3, 4 (High Band)

