

Package: SOT-115J

Product Description

The OS10040320PW is a hybrid high dynamic range optical receiver amplifier module. Two of the module pins are for connection to 24V (DC), one for amplifier supply voltage, the other for the PIN diode bias. The module contains a single mode optical input suitable for wavelengths from 1290nm to 1600nm, a terminal to monitor the PIN diode current, and an electrical output with an impedance of 75Ω. Fiberglass optical coupling; maximum tensile strength=5N; minimum bending radius=35 mm.

Features

- Superior Return Loss Performance
- Extremely Low Distortion
- Optimal Reliability
- Very Low EINC
- Standard CATV Outline
- Excellent Flatness
- 260mA Max. at 24VDC

Applications

- 40MHz to 1000MHz CATV Amplifier Systems

Optimum Technology Matching® Applied

<input type="checkbox"/>	GaAs HBT
<input checked="" type="checkbox"/>	GaAs MESFET
<input type="checkbox"/>	InGaP HBT
<input type="checkbox"/>	SiGe BiCMOS
<input type="checkbox"/>	Si BiCMOS
<input type="checkbox"/>	SiGe HBT
<input checked="" type="checkbox"/>	GaAs pHEMT
<input type="checkbox"/>	Si CMOS
<input type="checkbox"/>	Si BJT
<input type="checkbox"/>	GaN HEMT
<input type="checkbox"/>	RF MEMS

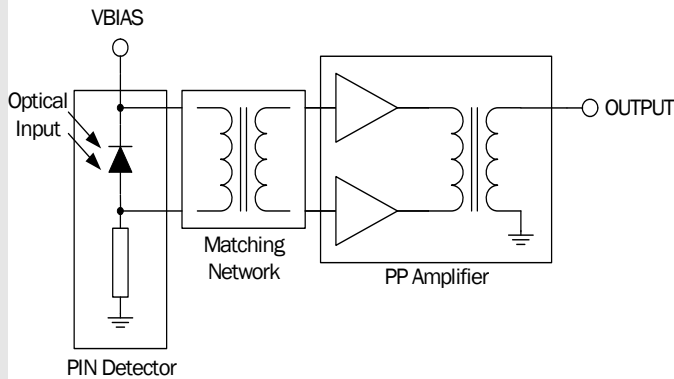

Parameter	Specification			Unit	Condition
	Min.	Typ.	Max.		
Overall					Bandwidth 40MHz to 1000MHz; V _B =24V; T _{MB} =30 °C; Z _L =75Ω
Responsivity	3000	3150		V/W	λ = 1310nm, f = 1000MHz
Slope ¹	0		2.0	dB	f = 40MHz to 1000MHz
Flatness of O/E response ²		<0.7	1.0	dB	f = 40MHz to 1000MHz
Optical Input Return Loss	45.0			dB	
Output Return Loss	15.0	17.0		dB	f = 40MHz to 1000MHz
Equivalent Input Noise		4.5	5.0	pA/√HZ	f = 40MHz to 400MHz
Equivalent Input Noise		5.0	5.5	pA/√HZ	f = 400MHz to 1000MHz
Spectral Sensitivity	0.88			A/W	λ = (1310+20)nm
	0.90			A/W	λ = (1550+20)nm
Optical Wavelength	1290		1600	nm	
Total Current Consumption (DC)		255	260	mA	module pin 4 and 5 connected to V _B
Photo diode bias current		6.0	10.0	mA	

1. Slope is defined as the difference between the O/E response at the start frequency and the O/E response at the stop frequency.
 2. Measured peak to valley.

Absolute Maximum Ratings

Parameter	Rating	Unit
Frequency Range	40 to 1000	MHz
Optical Input Power (continuous)	5	mW
ESD Sensitivity according to MIL-Standard 1686C (Human Body Model; R=1.5k Ω , C=100pF)	500	V
Storage Temperature	-40 to +85	$^{\circ}$ C
Operating Mounting Base Temperature	-20 to +85	$^{\circ}$ C



Caution! ESD sensitive device.

Exceeding any one or a combination of the Absolute Maximum Rating conditions may cause permanent damage to the device. Extended application of Absolute Maximum Rating conditions to the device may reduce device reliability. Specified typical performance or functional operation of the device under Absolute Maximum Rating conditions is not implied.

RoHS status based on EU Directive 2002/95/EC (at time of this document revision).

The information in this publication is believed to be accurate and reliable. However, no responsibility is assumed by RF Micro Devices, Inc. ("RFMD") for its use, nor for any infringement of patents, or other rights of third parties, resulting from its use. No license is granted by implication or otherwise under any patent or patent rights of RFMD. RFMD reserves the right to change component circuitry, recommended application circuitry and specifications at any time without prior notice.

Parameter	Specification			Unit	Condition
	Min.	Typ.	Max.		
Distortion data					$V_B = 24V$; $T_{MB} = 30^{\circ}C$; $Z_L = 75\Omega$
Second order distortion ^[3]		-75	-70	dBc	$f_m = 54.0MHz$ ^[4]
		-72	-67	dBc	$f_m = 446.5MHz$ ^[5]
		-70	-65	dBc	$f_m = 548.5MHz$ ^[6]
		-65	-61	dBc	$f_m = 746.5MHz$ ^[7]
		-64	-60	dBc	$f_m = 854.5MHz$ ^[8]
Third order distortion ^[9]		-75	-70	dBc	$f_m = 55.25MHz$ ^[10]
		-75	-70	dBc	$f_m = 445.25MHz$ ^[11]
		-72	-68	dBc	$f_m = 547.25MHz$ ^[12]
		-72	-67	dBc	$f_m = 745.25MHz$ ^[13]
		-72	-67	dBc	$f_m = 853.25MHz$ ^[14]

3. Two laser test; each laser with 40% modulation index; $P_{OPT} = 1mW$ (total).

4. $f_m = 54MHz$; $f_1 = 187.25MHz$; $f_2 = 133.25MHz$.

5. $f_m = 446.5MHz$; $f_1 = 97.25MHz$; $f_2 = 349.25MHz$.

6. $f_m = 548.5MHz$; $f_1 = 109.25MHz$; $f_2 = 439.25MHz$.

7. $f_m = 746.5MHz$; $f_1 = 133.25MHz$; $f_2 = 613.25MHz$.

8. $f_m = 854.5MHz$; $f_1 = 133.25MHz$; $f_2 = 721.25MHz$.

9. Three laser test; each laser with 60% modulation index; $P_{OPT} = 1mW$ (total).

10. $f_m = 55.25MHz$; $f_1 = 109.25MHz$; $f_2 = 133.25MHz$; $f_3 = 187.25MHz$.

11. $f_m = 445.25MHz$; $f_1 = 193.25MHz$; $f_2 = 349.25MHz$; $f_3 = 97.25MHz$.

12. $f_m = 547.25MHz$; $f_1 = 217.25MHz$; $f_2 = 439.25MHz$; $f_3 = 109.25MHz$.

13. $f_m = 745.25MHz$; $f_1 = 133.25MHz$; $f_2 = 265.25MHz$; $f_3 = 613.25MHz$.

14. $f_m = 853.25MHz$; $f_1 = 133.25MHz$; $f_2 = 265.25MHz$; $f_3 = 721.25MHz$.

Cable Lengths and Connector Types

Tab	Dimension A				Optical Connector Type
	Inches	Tolerance	mm	Tolerance	
-012	33.4	-4 to +0.5	848	-102 to +13	FC/APC
-013	33.4	-4 to +0.5	848	-102 to +13	SC/APC
-014	37.5	-3.5 to +0.5	952	-89 to +13	FC/APC
-015	37.5	-3.5 to +0.5	952	-89 to +13	SC/APC
-016	21.1	-1.5 to +0.5	536	-38 to +13	FC/APC
-017	21.1	-1.5 to +0.5	536	-38 to +13	SC/APC

Cable Lengths and Connector Types (cont.)

Tab	Dimension B	
	Inches	mm
-012	No outer jacket	
-013	No outer jacket	
-014	0.315 to 0.710	8.0 to 18.0
-015	0.315 to 0.710	8.0 to 18.0
-016	0.315 to 0.710	8.0 to 18.0
-017	0.315 to 0.710	8.0 to 18.0

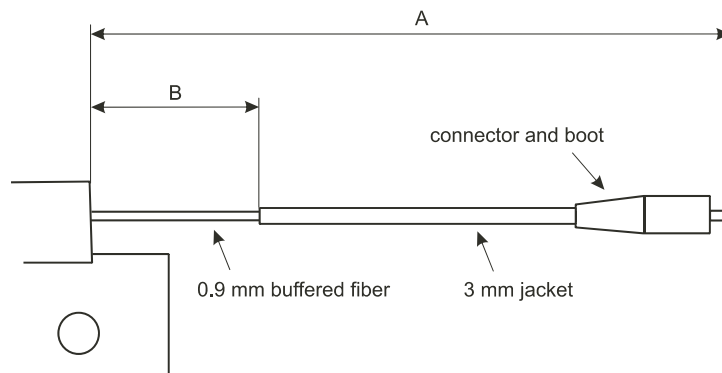
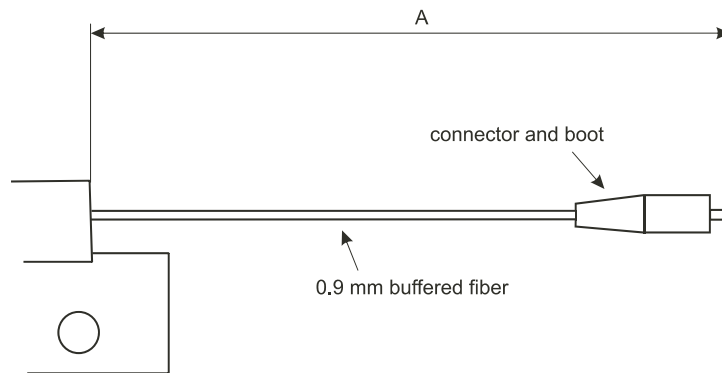

OS10040320PW



rfmd.com

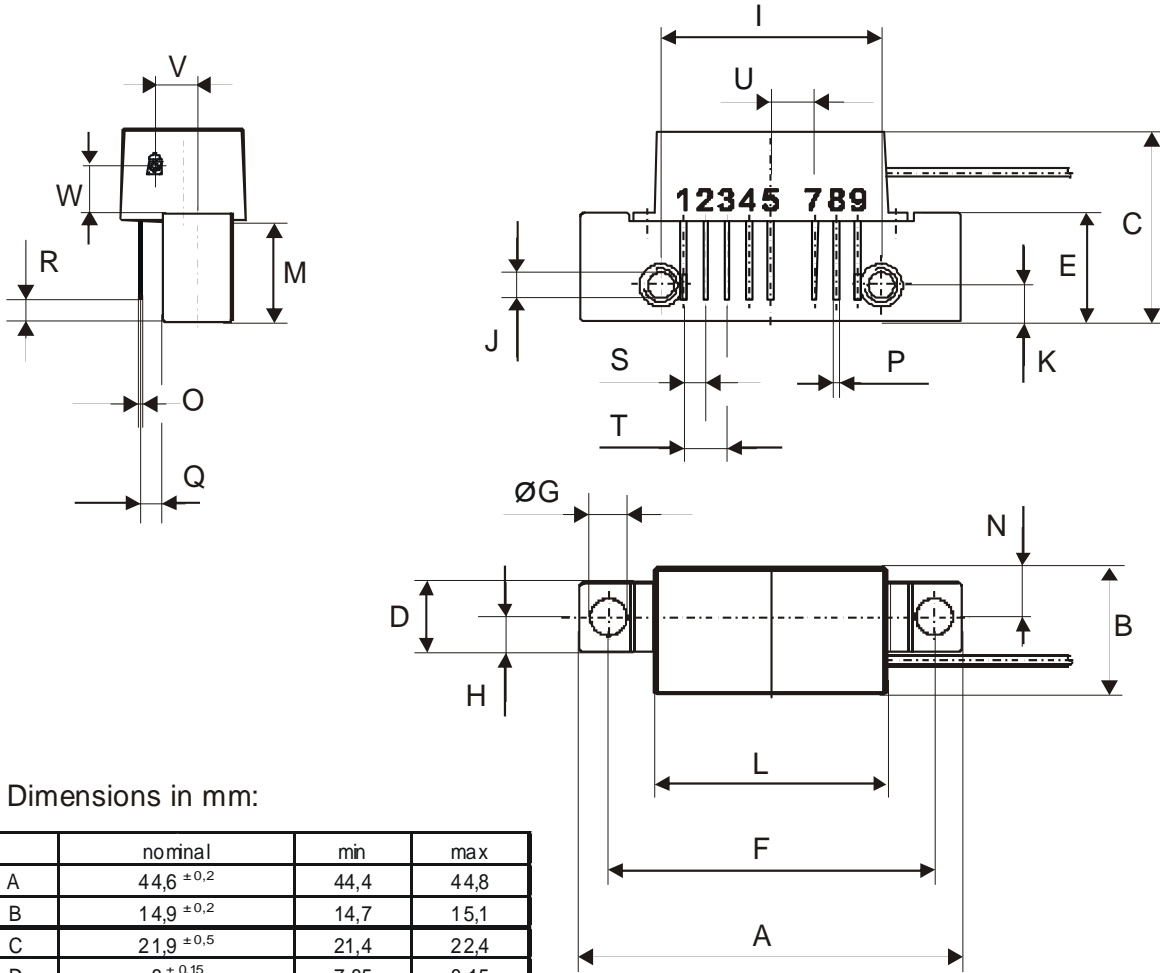

All Dimensions in mm:

	nominal	min	max
A	44,6 ±0,2	44,4	44,8
B	14,9 ±0,2	14,7	15,1
C	21,9 ±0,5	21,4	22,4
D	8 ±0,15	7,85	8,15
E	12,6 ±0,15	12,45	12,75
F	38,1 ±0,1	38,0	38,2
G	4 +0,2 / -0,05	3,95	4,2
H	4 ±0,2	3,8	4,2
I	25,4 ±0,2	25,2	25,6
J	UNC 6-32	-	-
K	4,2 ±0,2	4,0	4,4
L	28,7 ±0,2	28,5	28,9
M	11,6 ±0,5	11,1	12,1
N	5,8 ±0,4	5,4	6,2
O	0,25 ±0,02	0,23	0,27
P	0,45 ±0,03	0,42	0,48
Q	2,54 ±0,3	2,24	2,84
R	2,54 ±0,5	2,04	3,04
S	2,54 ±0,25	2,29	2,79
T	5,08 ±0,25	4,83	5,33
U	5,08 ±0,25	4,83	5,33
V	5,0 ±0,2	4,8	5,2
W	5,35		

Pinning:

1	PHOTODIODE CURRENT MONITOR
2	GND
3	GND
4	PHOTODIODE BIAS
5	+VB
6	
7	GND
8	GND
9	OUTPUT

Notes:

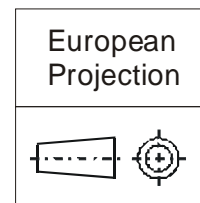

0 5 10mm

 scale

OS10040320PW



rfmd.com