

Features

- 30dB of Stepped LNA/Mixer Gain Control
- Adjustable Mixer & LNA Bias Current/IIP3
- A Divide-by-2 Prescaler
- Meets IMD Tests with Three Gain States/Two Logic Control Lines
- Integrated TX LO Buffer Amplifiers

Applications

- CDMA/Cellular/PCS Handsets
- CDMA Cellular/GPS Handsets
- JCDMA/GPS Handsets
- CDMA Modem/Data Cards
- Commercial and Consumer Systems
- Portable Battery-Powered Equipment

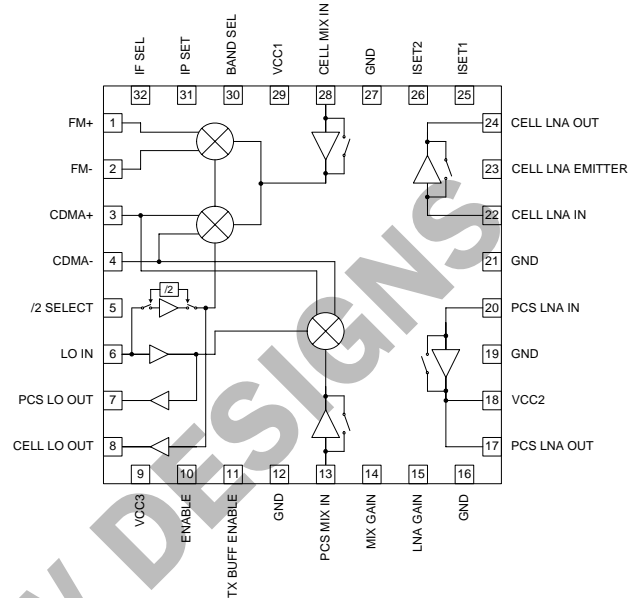

Functional Block Diagram

Product Description

The RF2489 is a high performance CDMA dual-band/tri-mode integrated LNA/mixer. The device is designed to meet all IS-98 sensitivity, intermodulation and single-tone requirements. The operating voltage is 2.7V and is compatible with 1.8V logic for control lines. The RF2489 integrates the dual-band LNA/downconverters with 30dB of gain control and TX LO buffers. Additionally, a divide-by-2 prescaler to allow the use of a single-band VCO is integrated. The design is flexible, in that the bias currents may be set using off-chip current reference resistors for both the LNA and mixer blocks. The device is packaged in a 5 mmx5mm leadless plastic package.

Ordering Information

RF2489	Dual-Band/Tri-Mode CDMA Low Noise Amplifier/Mixer
RF2489	Dual-Band/Tri-Mode JCDMA/GPS LNA/Mixer
RF2489PCBA-41X	Fully Assembled Evaluation Board

Optimum Technology Matching® Applied

- | | | | |
|--------------------------------------|---|-------------------------------------|-----------------------------------|
| <input type="checkbox"/> GaAs HBT | <input checked="" type="checkbox"/> SiGe BiCMOS | <input type="checkbox"/> GaAs pHEMT | <input type="checkbox"/> GaN HEMT |
| <input type="checkbox"/> GaAs MESFET | <input type="checkbox"/> Si BiCMOS | <input type="checkbox"/> Si CMOS | |
| <input type="checkbox"/> InGaP HBT | <input type="checkbox"/> SiGe HBT | <input type="checkbox"/> Si BJT | |

RF MICRO DEVICES®, RFMD®, Optimum Technology Matching®, Enabling Wireless Connectivity™, PowerStar®, POLARIS™ TOTAL RADIO™ and UltimateBlue™ are trademarks of RFMD, LLC. BLUETOOTH is a trademark owned by Bluetooth SIG, Inc., U.S.A. and licensed for use by RFMD. All other trade names, trademarks and registered trademarks are the property of their respective owners. ©2006, RF Micro Devices, Inc.

Absolute Maximum Ratings

Parameter	Rating	Unit
Supply Voltage	-0.5 to +5.0	V _{DC}
Input LO and RF Levels	+6	dBm
Operating Ambient Temperature	-40 to +85	°C
Storage Temperature	-40 to +150	°C



Caution! ESD sensitive device.

The information in this publication is believed to be accurate and reliable. However, no responsibility is assumed by RF Micro Devices, Inc. ("RFMD") for its use, nor for any infringement of patents, or other rights of third parties, resulting from its use. No license is granted by implication or otherwise under any patent or patent rights of RFMD. RFMD reserves the right to change component circuitry, recommended application circuitry and specifications at any time without prior notice.

RoHS status based on EUDirective2002/95/EC (at time of this document revision).

Parameter	Specification			Unit	Condition
	Min.	Typ.	Max.		
Overall					T = 25 °C, V _{CC} = 2.75V
RF Frequency Range		869 to 894		MHz	
		1930 to 1990		MHz	
		1575.42		MHz	GPS
IF Frequency Range		0.1 to 400		MHz	
Cellular Band					Freq = 869MHz to 894MHz
JCDMA Band					Freq = 832MHz to 870MHz
LNA (On)					LNA 50Ω match
Gain	13.5	15.0	16.5	dB	IP SET = 1
	13.0	14.5	16.0	dB	IP SET = 0
Noise Figure		1.1	1.3	dB	IP SET = 1
		1.1	1.3	dB	IP SET = 0
Input IP3	+8.0	+10.5		dBm	IP SET = 1
	+5.0	+8.5		dBm	IP SET = 0
Current		6.5		mA	IPSET = 1
		4.5		mA	IPSET = 0
Isolation		23		dB	
LNA (Off)					
Gain	-6.5	-5.0	-3.5	dB	
Noise Figure		5.0	5.5	dB	
Input IP3	+21.0	+25.0		dBm	
Current		0		mA	
Isolation		5		dB	
Mixer - CDMA/JCDMA					LO Input Level = -4 dBm
Gain	12.0	13.5	15.0	dB	Mixer Preamp ON
	2	4.5		dB	Mixer Preamp OFF
Noise Figure		7	8	dB	Mixer Preamp ON
		14	16	dB	Mixer Preamp OFF
Input IP3	+2.5	+3.5		dBm	Mixer Preamp ON
	+11.0	+14.0		dBm	Mixer Preamp OFF
Current		19.5		mA	Mixer Preamp ON/Mixer/LO Input Amps
		15.0		mA	Mixer Preamp OFF/Mixer/LO Input Amps
LO to RF Isolation	36			dB	Mixer Preamp ON
	30			dB	Mixer Preamp OFF

Parameter	Specification			Unit	Condition
	Min.	Typ.	Max.		
Cellular Band					Freq = 869MHz to 894MHz
JCDMA Band, cont'd					Freq = 832MHz to 870MHz
Mixer - FM					LO Input Level = -4dBm
Gain	11	13	15	dB	Mixer Preamp ON
	2	4		dB	Mixer Preamp OFF
Noise Figure		7	8	dB	Mixer Preamp ON
		14	16	dB	Mixer Preamp OFF
Input IP3	+2.5	+4.5		dBm	Mixer Preamp ON
	+13.0	+15.0		dBm	Mixer Preamp OFF
Current		19.5		mA	Mixer Preamp ON/Mixer/LO Input Amps
		15.0		mA	Mixer Preamp OFF/Mixer/LO Input Amps
LO to RF Isolation	36			dB	Mixer Preamp ON
	30			dB	Mixer Preamp OFF
Other					
LO-IF Isolation	30			dB	
RF-IF Isolation	40			dB	
LNA Out to Mixer In Isolation	40	50		dB	
LO-LNA In Isolation, Any State	35			dB	
PCS Band					Freq = 1930MHz to 1990MHz Freq = 1840MHz to 1870MHz
LNA (On)					LNA 50Ω match
Gain	14.5	16.0	17.0	dB	IP SET=1
	13.5	15.0	17.0	dB	IP SET=0
Noise Figure		1.4	1.6	dB	IP SET=1
		1.3	1.6	dB	IP SET=0
Input IP3	+6.0	+8.0		dBm	IP SET=1
	-2.5	+1.0		dBm	IP SET=0
Current		6.5		mA	IP SET=1
		4.5		mA	IP SET=0
Isolation		20		dB	
LNA (Off)					
Gain	-7.5	-5.0	-4.0	dB	
Noise Figure		5	6	dB	
Input IP3	+23.0	+26.0		dBm	
Current		0		mA	
Isolation		5		dB	
Mixer					LO Input Level = -4dBm
Gain	11.0	13.5	15.0	dB	Mixer Preamp ON
	0	4	6	dB	Mixer Preamp OFF
Noise Figure		8.0	9.5	dB	Mixer Preamp ON
		15		dB	Mixer Preamp OFF
Input IP3	+2.0	+4.0		dBm	Mixer Preamp ON
	+11.0	+13.0		dBm	Mixer Preamp OFF
Current		19.5		mA	Mixer Preamp ON/Mixer/LO Input Amps
		15.0		mA	Mixer Preamp OFF/Mixer/LO Input Amps
LO to RF Isolation	36			dB	Mixer Preamp ON
	30			dB	Mixer Preamp OFF

Parameter	Specification			Unit	Condition
	Min.	Typ.	Max.		
Other					
LO-IF Isolation	36			dB	
RF-IF Isolation	40			dB	
LNA Out to Mixer In Isolation	30	40		dB	
LO-LNA In Isolation, Any State	35			dB	
GPS Frequency					Freq = 1575.42 MHz
LNA (On)					LNA 50Ω match
Gain	16.5	18.0		dB	IP SET= 1
	15.5	16.5		dB	IP SET=0
Noise Figure		1.4	1.6	dB	IP SET= 1
		1.3	1.6	dB	IP SET=0
Input IP3	-6.0	-5.0		dBm	IP SET= 1
	-11.0	-9.0		dBm	IP SET=0
Current		6.5		mA	IP SET= 1
		4.5		mA	IP SET=0
Isolation		20		dB	
Mixer					Mixer RF amp ON LO Input Level = -4 dBm
Gain	15	16	17	dB	
Noise Figure		7	9	dB	
Input IP3	+1.0	+1.5		dBm	
Current		19.5		mA	
LO to RF Isolation	36			dB	
Other					
LO-IF Isolation	36			dB	
RF-IF Isolation	40			dB	
LNA Out to Mixer In Isolation	30	40		dB	
LO-LNA In Isolation, Any State	35			dB	
Control Lines					
Input Capacitance			1	pF	BAND SEL, IF SEL, IP SET, LNA GAIN, ENABLE, MIX GAIN, TX BUFF ENABLE, /2 SELECT

NOT FOR NEW DESIGNS

Parameter	Specification			Unit	Condition
	Min.	Typ.	Max.		
Local Oscillator Input					
Cellular - CDMA/FM					
Input Power	-10	-4	0	dBm	
Input Frequency		685-710		MHz	IF= 184MHz
		1053-1078		MHz	IF= 184MHz
		1370-1420		MHz	IF= 184MHz with /2 SELECT=1
		2106-2156		MHz	IF= 184MHz with /2 SELECT=1
Cellular - JCDMA					
Input Power	-10	-4	0	dBm	
Input Frequency		722-760		MHz	IF= 110MHz
		942-980		MHz	IF= 110MHz
		1444-1520		MHz	IF= 110MHz with /2 SELECT=1
		1884-1960		MHz	IF= 110MHz with /2 SELECT=1
PCS					
Input Power	-10	-4	0	dBm	
Input Frequency		1746-1806		MHz	IF= 184MHz
		2114-2174		MHz	IF= 184MHz
GPS					
Input Power	-10	-4	0	dBm	
Input Frequency		1465.42		MHz	IF= 110MHz
		1685.42		MHz	IF= 110MHz
		1391.82		MHz	IF= 184MHz
		1759.02		MHz	IF= 184MHz
TX (Local Oscillator) Buffer					
Cellular - CDMA/FM					
Output Power	-12	-8		dBm	Single-ended 50Ω load, /2 SELECT=1
Output Frequency		685-710		MHz	IF= 184MHz
		1053-1078		MHz	IF= 184MHz
		1370-1420		MHz	IF= 184MHz with /2 SELECT=1
		2106-2156		MHz	IF= 184MHz with /2 SELECT=1
Current Consumption			2	mA	
Cellular - JCDMA					
Output Power	-12	-8		dBm	Single-ended 50Ω load, /2 SELECT=1
Output Frequency		722-760		MHz	IF= 110MHz
		942-980		MHz	IF= 110MHz
		1444-1520		MHz	IF= 110MHz with /2 SELECT=1
		1884-1960		MHz	IF= 110MHz with /2 SELECT=1
Current Consumption			2	mA	
PCS					
Output Power	-12	-9		dBm	Single-ended 50Ω load
Output Frequency		1746-1806		MHz	IF= 184MHz
		2114-2174		MHz	IF= 184MHz
Current Consumption			2	mA	

Evaluation Board Current Measurement

	BAND SEL	IF SEL	ENABLE	LNA GAIN	MIX GAIN	IP SET	TX BUFF ENABLE	/2 SELECT	IDC (mA)
CDMA Cellular JCDMA									
LNA On, Mixer Preamp On, TX Buffer Off, /2 Off	0	0	1	1	1	0	0	0	27.5
LNA On, Mixer Preamp Off, TX Buffer Off, /2 Off	0	0	1	1	0	0	0	0	23.0
LNA Bypassed, Mixer Preamp On, TX Buffer Off, /2 Off	0	0	1	0	1	0	0	0	23.0
LNA Bypassed, Mixer Preamp Off, TX Buffer Off, /2 Off	0	0	1	0	0	0	0	0	18.5

FM									
LNA On, Mixer Preamp On, TX Buffer Off, /2 Off	0	1	1	1	1	0	0	0	27.5
LNA On, Mixer Preamp Off, TX Buffer Off, /2 Off	0	1	1	1	0	0	0	0	23.0
LNA Bypassed, Mixer Preamp On, TX Buffer Off, /2 Off	0	1	1	0	1	0	0	0	23.0
LNA Bypassed, Mixer Preamp Off, TX Buffer Off, /2 Off	0	1	1	0	0	0	0	0	18.5

CDMA PCS - High IIP3 LNA Mode									
LNA On, Mixer Preamp On, TX Buffer Off, /2 Off	1	0	1	1	1	1	0	0	29.5
LNA Off, Mixer Preamp Off, TX Buffer Off, /2 Off	1	0	1	1	0	1	0	0	25.0
LNA Bypassed, Mixer Preamp On, TX Buffer Off, /2 Off	1	0	1	0	1	1	0	0	23.0
LNA Bypassed, Mixer Preamp Off, TX Buffer Off, /2 Off	1	0	1	0	0	1	0	0	18.5

GPS									
LNA On, Mixer On	1	0	1	1	1	1	0	0	26.0

NOTES:

All IDC current numbers include bias circuitry current of 3.5mA.

TX Buffer On: Add 2mA to total current.

/2 Select On: Add 2mA to total current.

“X” denotes setting does not impact current.

Cascaded Performance (Typical Values for $V_{CC}=2.75V$)

NOTE: All total current numbers include bias circuitry current of 3.5 μ A.

<i>Parameter</i>	CELL CDMA			
	LNA ON	LNA OFF	LNA ON	LNA OFF
	<i>Mixer Preamp On</i>		<i>Mixer Preamp Off</i>	
Cascaded:				
Gain (dB)	25.0	5.5	16.0	-3.5
Noise Figure (dB)	2.1	15.0	4.8	22.0
Input IP3 (dBm)	-7.8	+11.3	+1.5	+20.24
LO to IF Isolation (dB)	30	30	30	30
IF1 to RF Isolation (dB)	40	40	40	40
IF2 to RF Isolation (dB)	40	40	40	40
LO to LNA IN Isolation (dB)	40	40	40	40
Total Current (mA)	27.5	23.0	23.0	18.5

NOTE: Assumes 3dB image filter insertion loss. The TX Buffer Enable is off. Div/2 function is off. Numbers represent low current LNA bias setting IPSET=0.

<i>Parameter</i>	FM			
	LNA ON	LNA OFF	LNA ON	LNA OFF
	<i>Mixer Preamp On</i>		<i>Mixer Preamp Off</i>	
Cascaded:				
Gain (dB)	24.5	5.0	15.5	-4.0
Noise Figure (dB)	2.1	15.0	4.8	22.0
Input IP3 (dBm)	-6.6	+12.7	+2.3	+20.8
LO to IF Isolation (dB)	30	30	30	30
IF1 to RF Isolation (dB)	40	40	40	40
IF2 to RF Isolation (dB)	40	40	40	40
LO to LNA IN Isolation (dB)	40	40	40	40
Total Current (mA)	27.5	23.0	23.0	18.5

NOTE: Assumes 3dB image filter insertion loss. The TX Buffer Enable is off. Div/2 function is off. Numbers represent low current LNA bias setting IPSET=0.

Parameter	PCS CDMA					
	LNA ON				LNA OFF	
	LNA at Max IIP3, IPSET=1		LNA at Min IIP3, IPSET=0			
	Mixer Amp ON	Mixer Amp OFF	Mixer Amp ON	Mixer Amp OFF	Mixer Amp ON	Mixer Amp OFF
Cascaded:						
Gain (dB)	26.5	17.0	25.5	16.0	5.5	-4.0
Noise Figure (dB)	2.2	4.7	2.3	5.2	16.0	23.0
Input IP3 (dBm)	-9.1	-0.6	-8.5	-2.0	+11.8	+19.8
LO to IF Isolation (dB)	30	30	30	30	30	30
IF1 to RF Isolation (dB)	40	40	40	40	40	40
IF2 to RF Isolation (dB)	40	40	40	40	40	40
LO to LNA IN Isolation (dB)	40	40	40	40	40	40
Total Current (mA)	29.5	25.0	27.5	23.0	23.0	18.5

NOTE: Assumes 3dB image filter insertion loss. The TX Buffer Enable is off. Div/2 function is off.

Parameter	GPS
Cascaded:	
Gain (dB)	32.5
Noise Figure (dB)	1.7
Input IP3 (dBm)	-15.4
Total Current (mA)	26.0

NOTE: Assumes 1.5dB image filter insertion loss. The TX Buffer Enable is off. /2 Select is off.

NOT FOR NEW DESIGNS

Control Logic (Single VCO)

Mode	BAND SEL	IF SEL	ENABLE	TX BUFF ENABLE	/2 SELECT
Cellular FM	0	1	1	X	1
Cellular CDMA	0	0	1	X	1
PCS CDMA	1	0	1	X	X
Power Down	1	1	1	X	X
Power Down 2	X	X	0	X	X
TX Buffer Enabled	X	X	1	1	X
/2 Enabled	0	X	1	X	1

Control Logic (Dual VCO)

Mode	BAND SEL	IF SEL	ENABLE	TX BUFF ENABLE	/2 SELECT
Cellular FM	0	1	1	X	0
Cellular CDMA	0	0	1	X	0
PCS CDMA	1	0	1	X	X
Power Down	1	1	1	X	X
Power Down 2	X	X	0	X	X
TX Buffer Enabled	X	X	1	1	X
/2 Enabled	0	X	1	X	1

Application Note 1

The PCS TX LO output pin (pin 7) and the CELL TX LO output pin (pin 8) can be combined. When BAND SEL is set low, the PCS band LO limiter and PCS TX LO buffer are off. Also, when BAND SEL is set high, the cellular band LO limiter and frequency divider are off as well as the cellular TX LO buffer. The LO leakage through the path of the disabled LO limiter/divider and TX LO buffer is insignificant.

Typical LO isolation test data follows:

LO Input Frequency=2128MHz, $P_{IN}=-4$ dBm, BAND SEL=0, /2 SELECT=1

$P_{OUTPIN8}=-28$ dBm at 2128MHz

$P_{OUTPIN8}=-11$ dBm at 1064MHz

$P_{OUTPIN7}=-34$ dBm at 2128MHz

Pin	Function	Description	Interface Schematic
1	FM+	FM IF output. Open collector. "Current combiner" IF interface to SAW filter recommended.	
2	FM-	FM IF output. Open collector. "Current combiner" IF interface to SAW filter recommended.	See pin 1.
3	CDMA+	CDMA IF output. Open collector.	
4	CDMA-	CDMA IF output. Open collector.	See pin 3.
5	/2 SELECT	Enable /2 circuitry in cellular mode. High enables /2 circuitry. The divider is disabled when BAND SEL (pin 30) is high, regardless of the state of pin 5. The divider can only be enabled when BAND SEL is low and pin 5 is high. Pin 5 can be tied to a high state allowing BAND SEL (pin 30) to control the LO divider function, if using a single LO input source.	
6	LO IN	LO single-end input. Internal DC block.	
7	PCS LO OUT	PCS LO output. Internal DC block. If a single TX VCO is required, pins 7 and 8 can be tied together and used as one LO output. (See application note 1.)	
8	CELL LO OUT	Cellular LO output. Internal DC block. (See application note 1.)	
9	VCC3	VCC connection for internal LO amplifiers. Internal RF bypass capacitor. External bypass capacitor between 1nF and 47nF required.	
10	ENABLE	Logic input. Low level powers down IC. IC can be shut down by setting pins 30 and 32 high and TX Buffer Enable low as well.	
11	TX BUFFER ENABLE	Logic input. High enables TX LO buffer amplifiers.	
12	GND	Low-inductance ground required.	
13	PCS MIX IN	PCS mixer RF single-end input.	
14	MIX GAIN	Logic input. Logic high turns on PCS or cellular mixer preamp and mixer provides maximum gain. Logic low will bypass the PCS and cellular mixer preamp.	
15	LNA GAIN	Logic input. High activates CDMA or PCS LNAs. Low selects LNA bypass mode for both bands.	

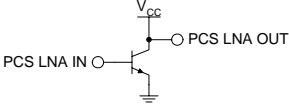
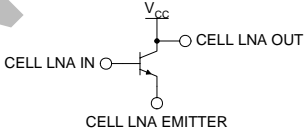
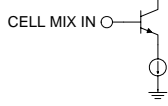
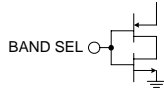
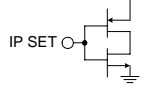
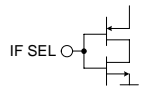
Pin	Function	Description	Interface Schematic
16	GND	Low-inductance ground required.	
17	PCS LNA OUT	PCS LNA output. Small external inductance required for best impedance match to 50Ω.	
18	VCC2	PCS LNA VCC connection. A series inductance required for matching.	
19	GND	Low-inductance ground required.	
20	PCS LNA IN	PCS LNA input. Simple external matching required for best performance.	See pin 17.
21	GND	Low-inductance ground required.	
22	CELL LNA IN	Cellular LNA input. Simple external matching required for best performance.	
23	CELL LNA EMITTER	Cellular LNA emitter. A small inductor connects this pin to ground. Cellular LNA gain can be adjusted by the inductance.	See pin 22.
24	CELL LNA OUT	Cellular LNA output. Simple external L-C matching required.	See pin 22.
25	ISET1	Resistor to ground sets both LNA and mixer currents. Lower resistance results in lower currents for both the LNA and mixer.	
26	ISET2	Resistor to ground sets LNA current. Higher resistance results in lower current.	
27	GND	Low-inductance ground required.	
28	CELL MIX IN	Cellular mixer RF single-end input. External L-C network required for best performance.	
29	VCC1	VCC for internal references, logic, and mixer preamplifiers. Internal RF bypass capacitor. External bypass capacitor between 1nF and 47nF required.	
30	BAND SEL	Logic input. High level selects PCS band; low level selects cellular band. The LO divider circuitry is disabled when BAND SEL is high, regardless of the state of pin 5 (/2 SELECT). When BAND SEL is low, pin 5 can be selected high or low. If using a single LO input, pin 5 can be tied to a high state allowing BAND SEL to control the LO divider function.	
31	IP SET	Logic input. High selects external LNA current reference set by the resistor connected from ISET2 to ground.	
32	IF SEL	Logic input. High selects FM IF outputs; low selects CDMA IF outputs.	

Package Drawing

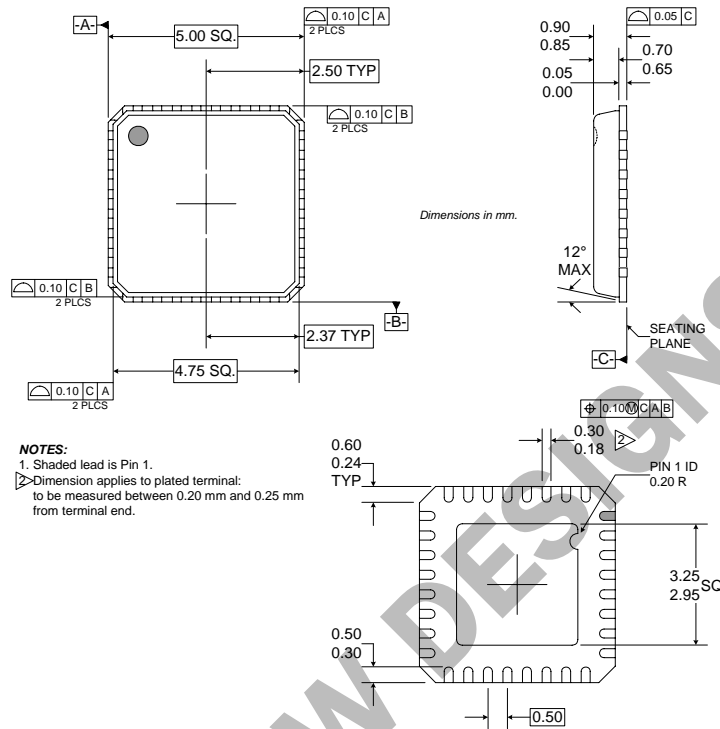

NOT FOR NEW DESIGNS

Application Schematic with Dual-Band TX LO Buffer Output

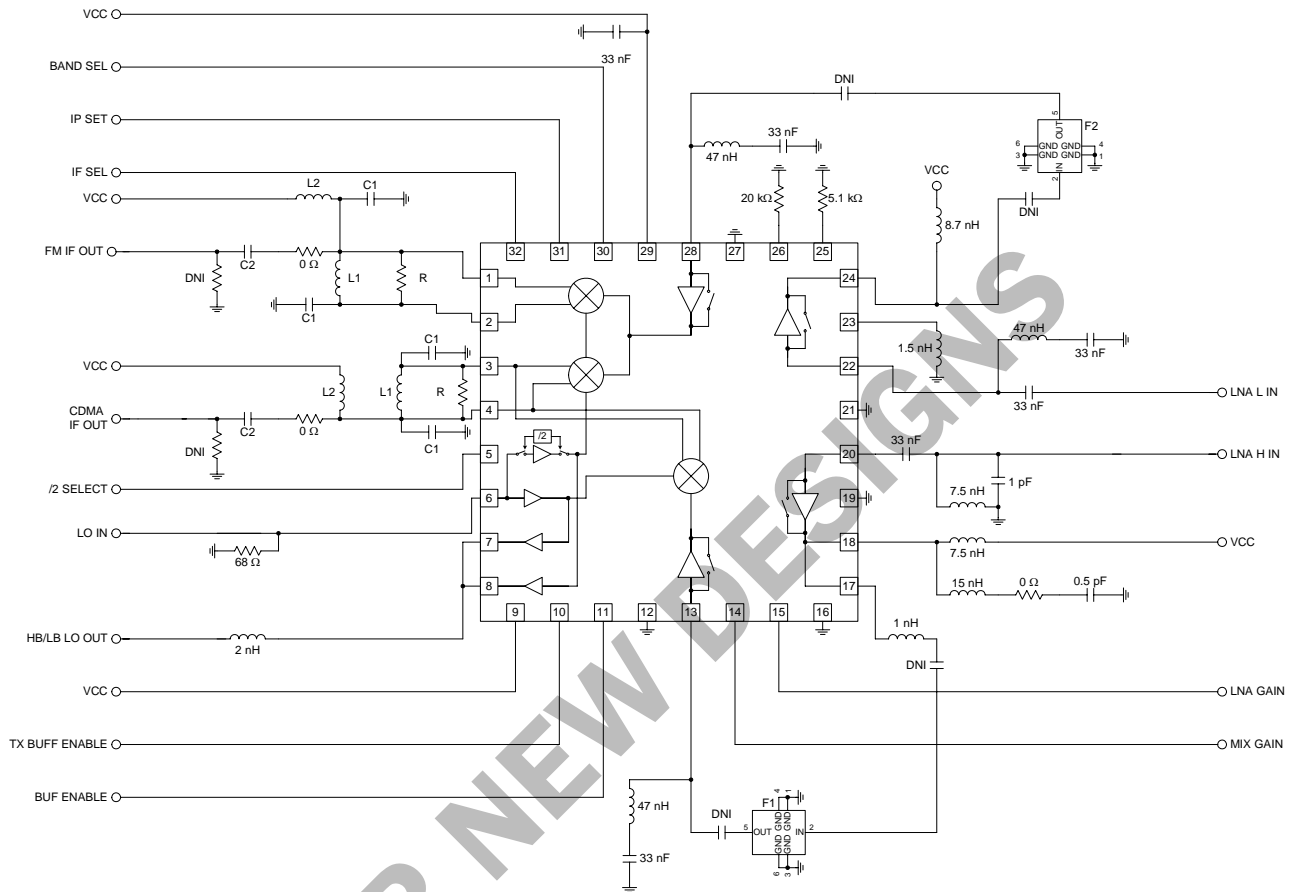

Output Interface Network

L1, C1, and R form a current combiner which performs a differential to single-ended conversion at the IF frequency and sets the output impedance. In most cases, the resonance frequency is independent of R and can be set according to the following equation:

$$f_{IF} = \frac{1}{2\pi\sqrt{\frac{L1}{2}(C1 + C_{EQ})}}$$

Where C_{EQ} is the equivalent stray capacitance and capacitance looking into pins 1 and 2. An average value to use for C_{EQ} is 2.5pF to 3pF.

R can then be used to set the output impedance according to the following equation:

$$R = \left(\frac{1}{4 \cdot R_{OUT}} - \frac{1}{R_P} \right)^{-1}$$

where R_{OUT} is the desired output impedance and R_P is the parasitic equivalent parallel resistance of L1.

C1 should be chosen as high as possible (not greater than 22pF), while maintaining an R_P of L1 that allows for the desired R_{OUT} .

L2 and C2 serve dual purposes. L2 serves as an output bias choke, and C2 serves as a series DC block.

In addition, L2 and C2 may be chosen to form an impedance matching network if the input impedance of the IF filter is not equal to R_{OUT} . Otherwise, L2 is chosen to be large, and C2 is chosen to be large if a DC path to ground is present in the IF filter, or omitted if the filter is DC blocked.

Evaluation Board Schematic IF@184MHz

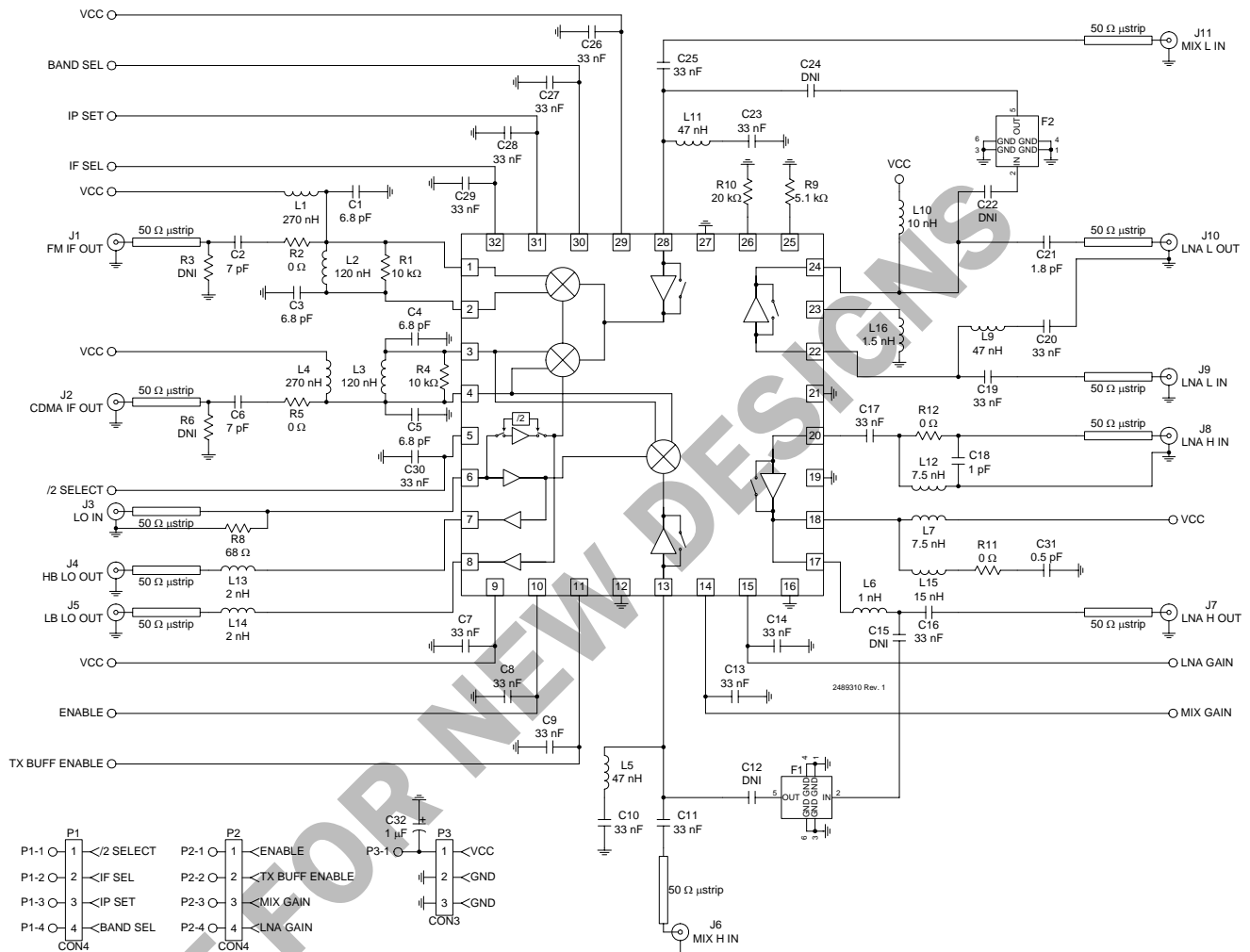

Evaluation Board Schematic JCDMA/GPS IF@110MHz

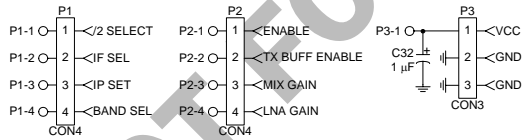
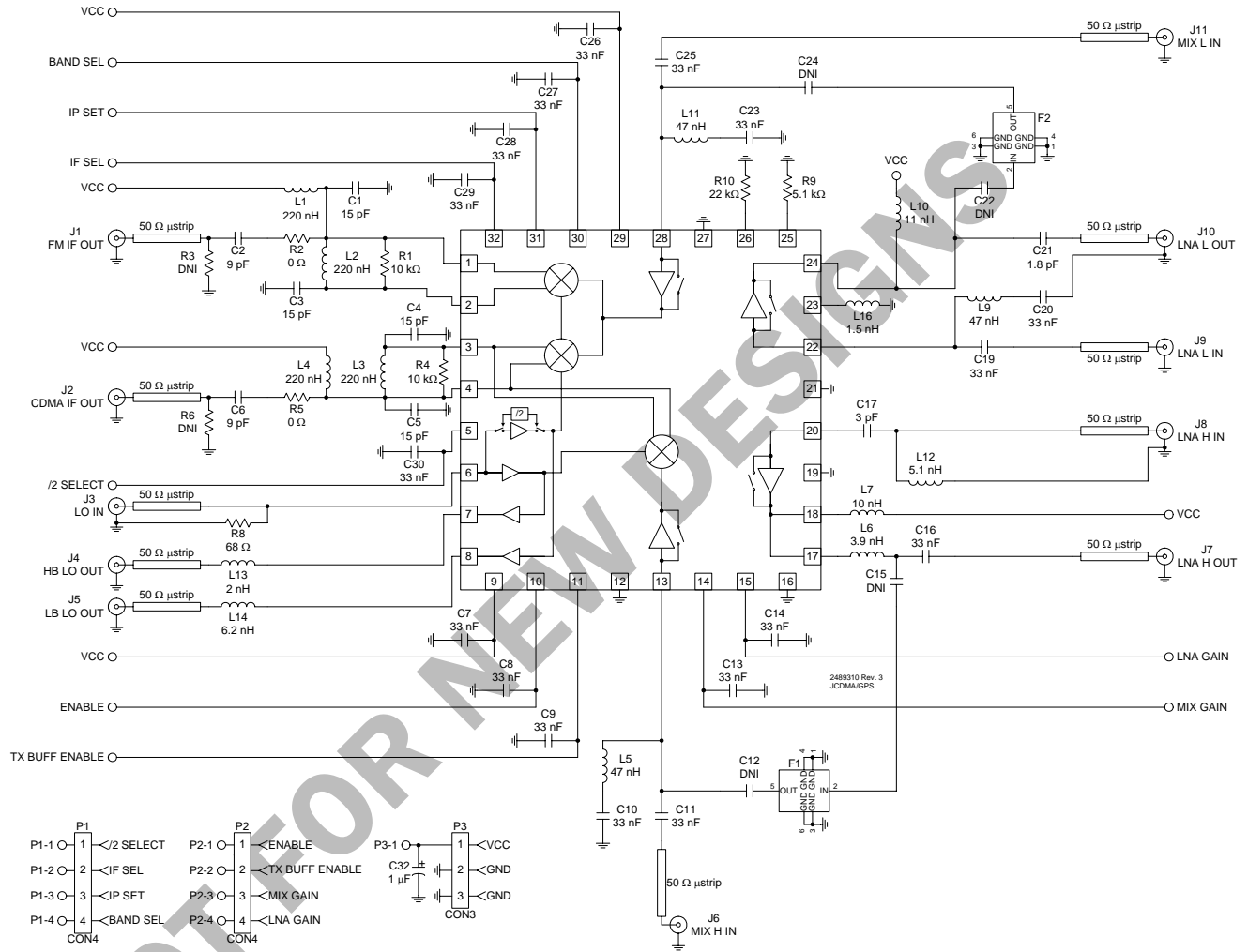

Evaluation Board Layout Board Size 3.100" x 2.958"

Board Thickness 0.064", Board Material FR-4, Multi-Layer

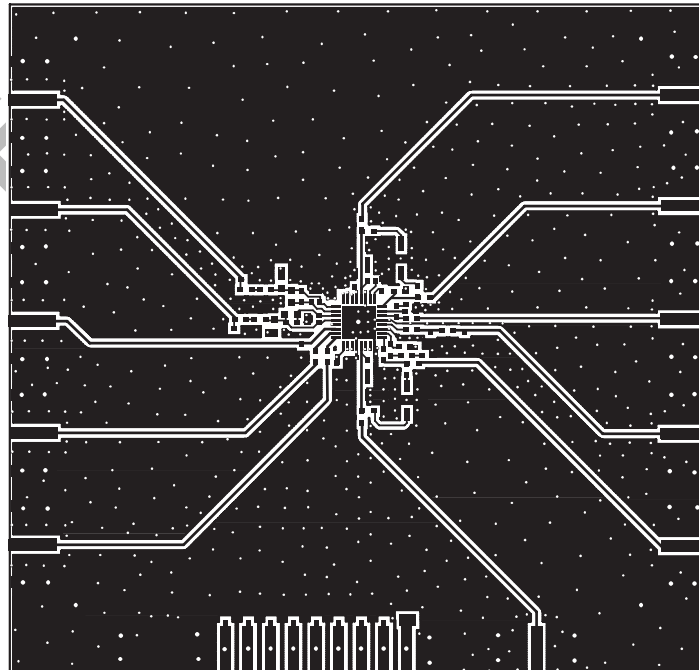
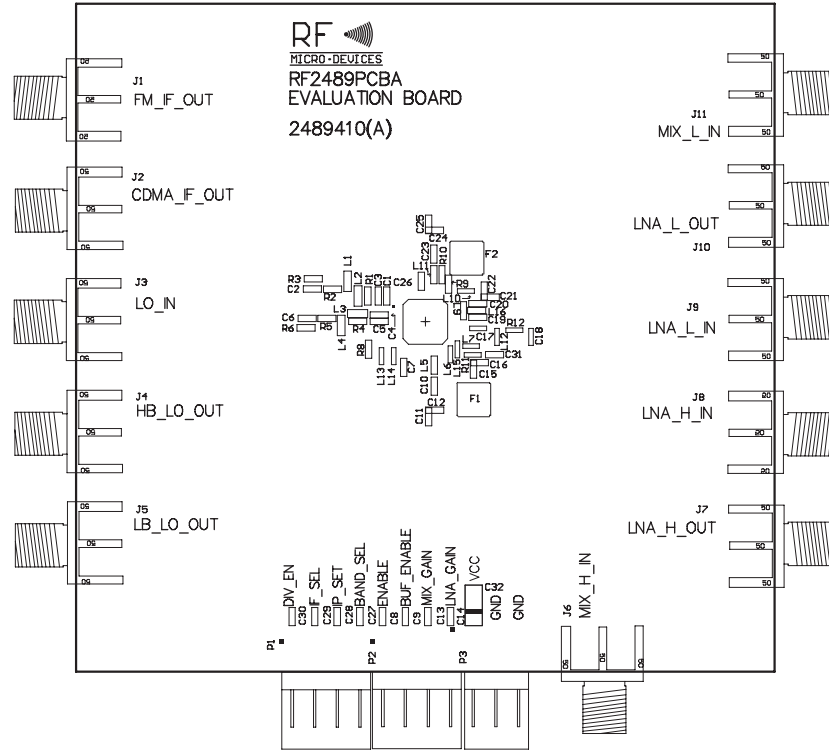

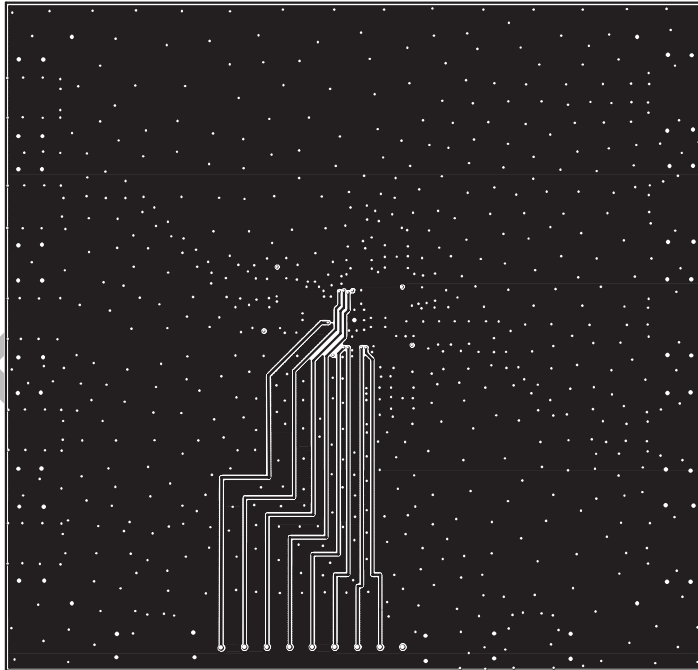
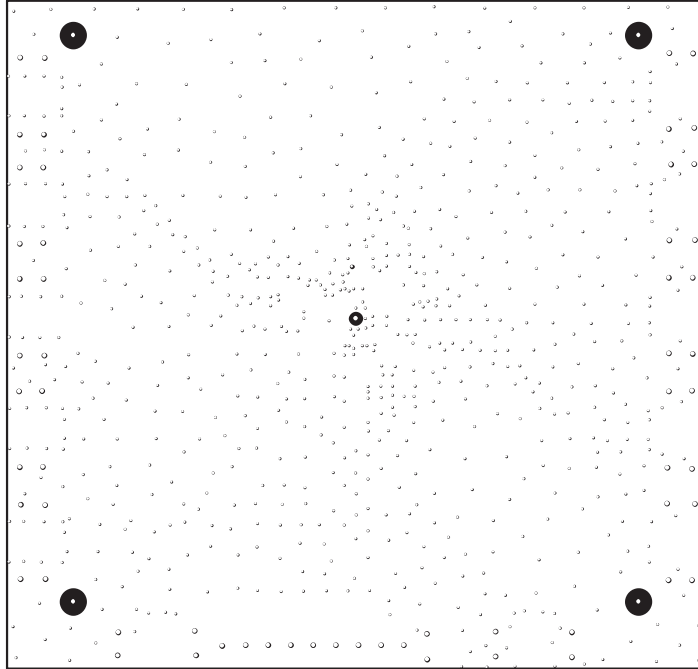

LNA Cellular Mode (High Gain / Nominal IP3 Mode)

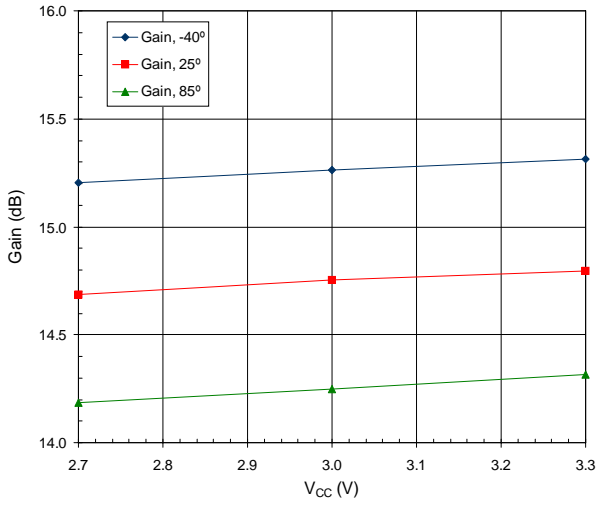

LNA Cellular Mode (High Gain / Max IP3 Mode)

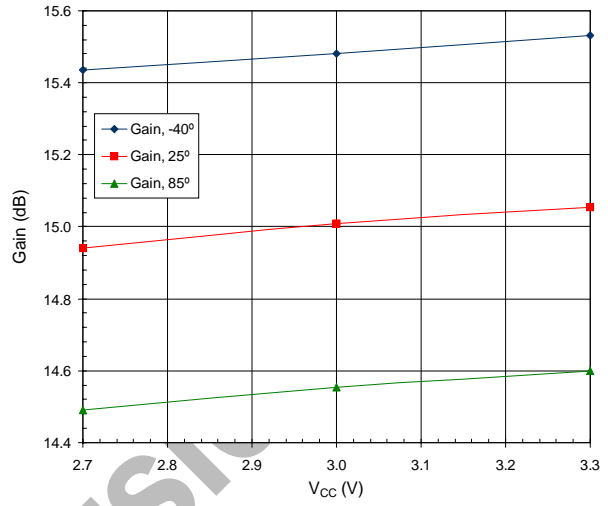

LNA Cellular Mode (High Gain / Nominal IP3 Mode)

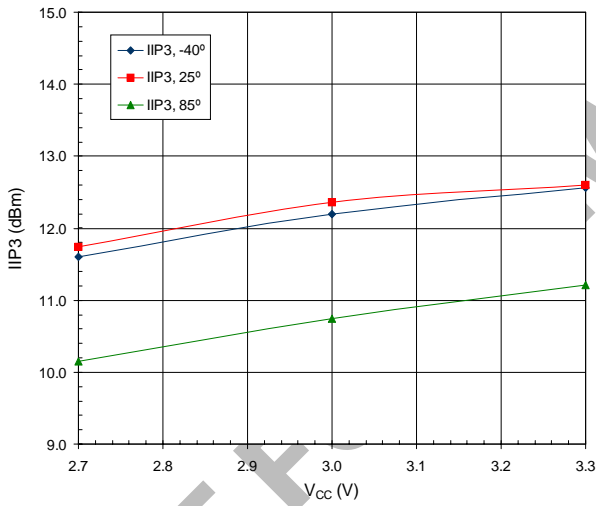

LNA Cellular Mode (High Gain / Max IP3 mode)

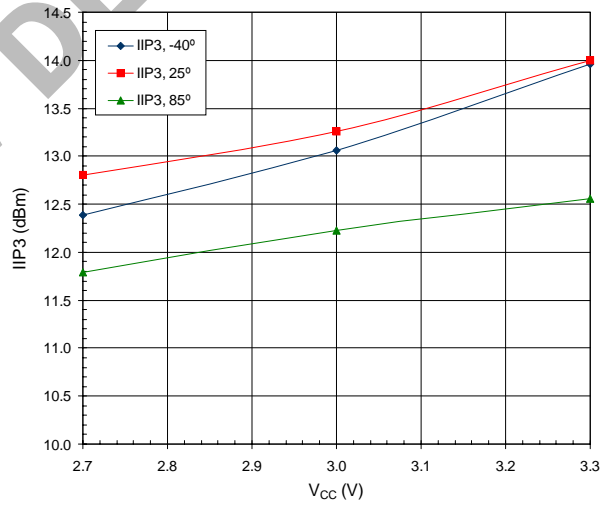

LNA Cellular Mode (High Gain / Nominal IP3 Mode)

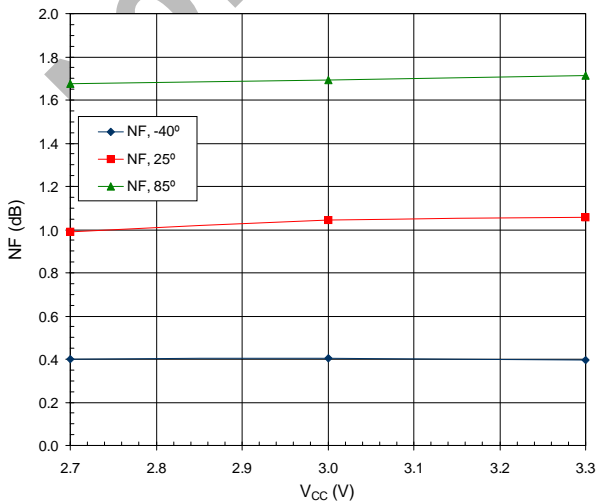

LNA Cellular Mode (High Gain / Max IP3 Mode)

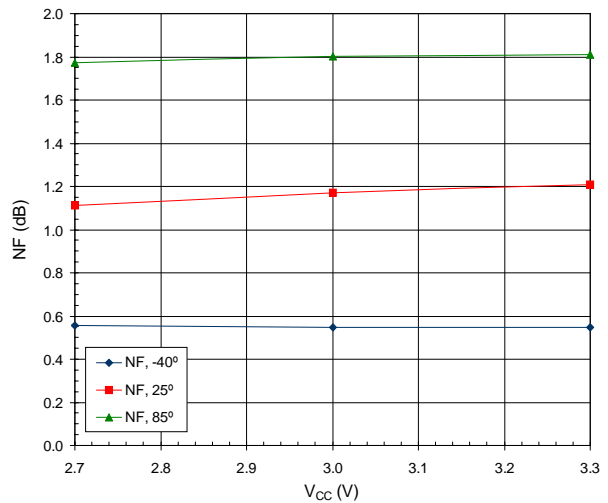

LNA Cellular Band (Low Gain Mode)

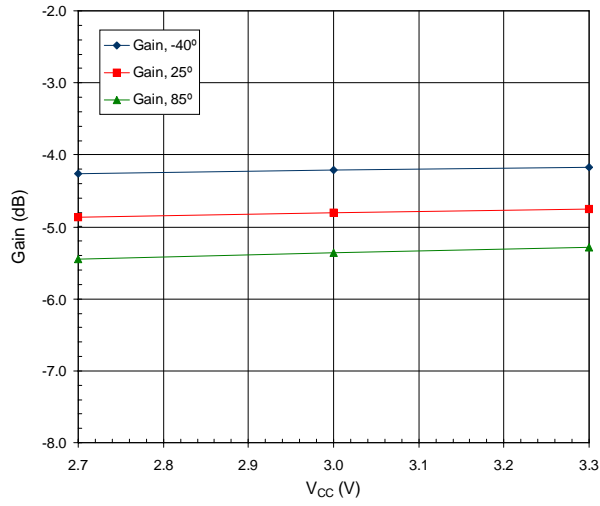

LNA Cellular Band (Low Gain Mode)

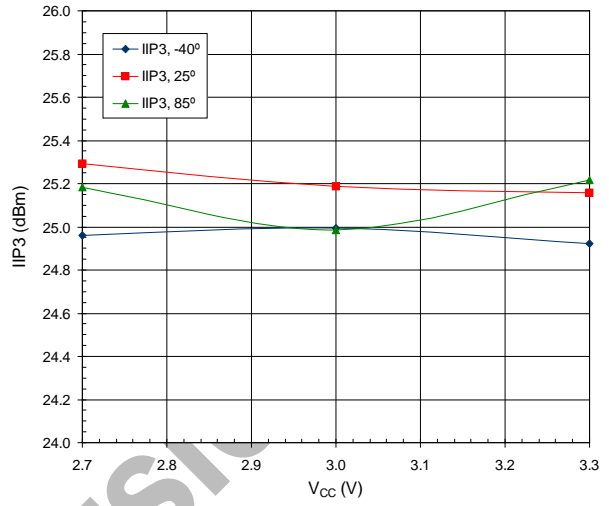

NOT FOR NEW DESIGN

Cellular Band, Mixer FM, High Gain Mode, LO @ -4dBm

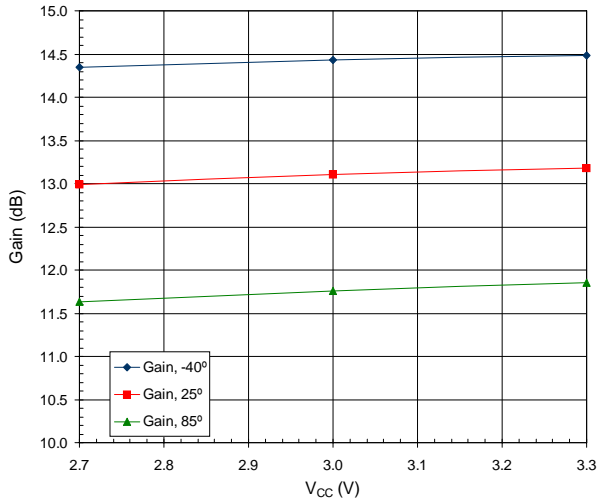

Cellular Band, Mixer FM, Low Gain Mode, LO @ -4dBm

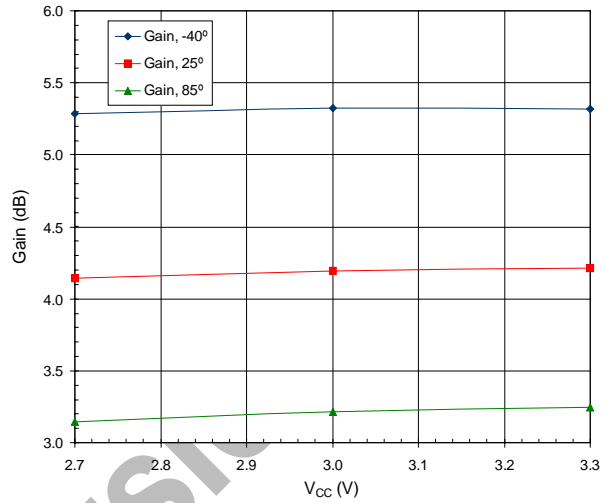

Cellular Band, Mixer FM, High Gain Mode, LO @ -4dBm

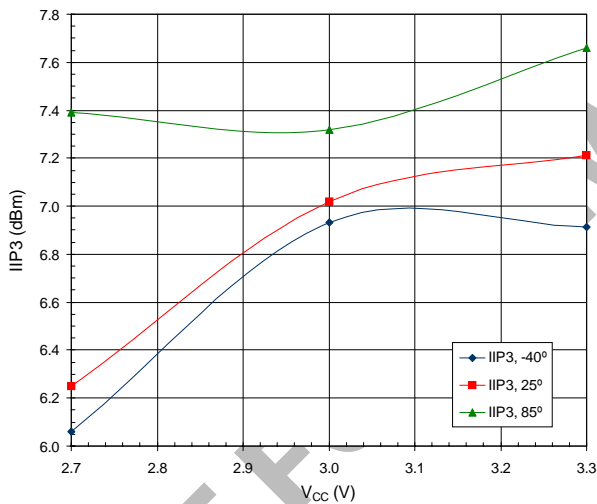

Cellular Band, Mixer FM, Low Gain Mode, LO @ -4dB

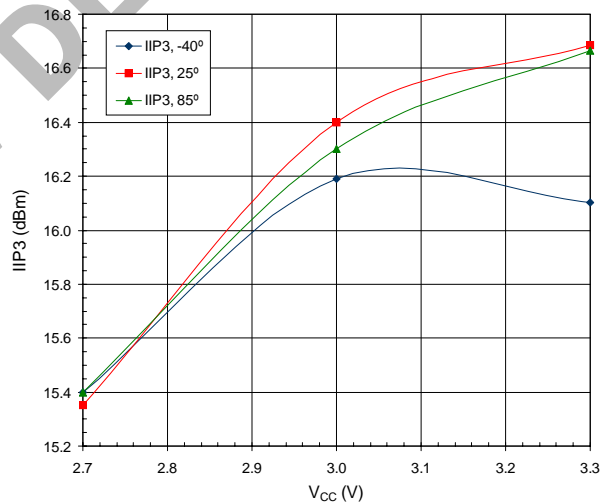

Cellular Band, Mixer FM, High Gain Mode, LO @ -4dBm

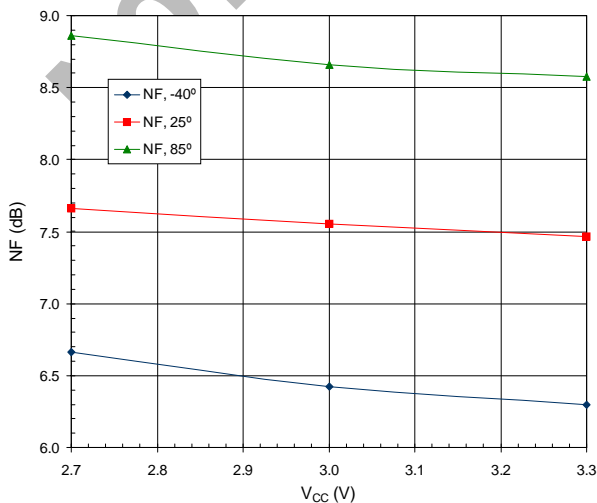

Cellular Band, Mixer FM, Low Gain Mode, LO @ -4dBm

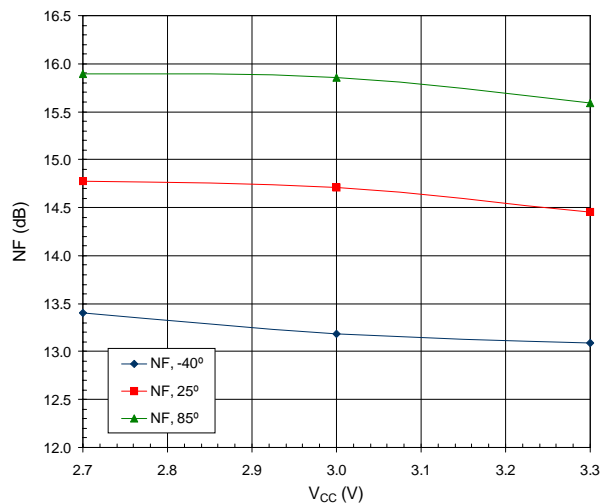

Cellular Band, Mixer FM, High Gain Mode, LO @ -4dBm

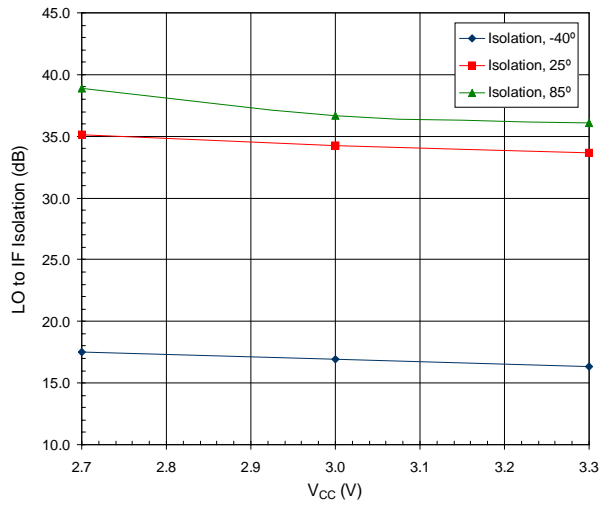

Cellular Band, Mixer FM, High Gain Mode, V_{CC}@2.7V

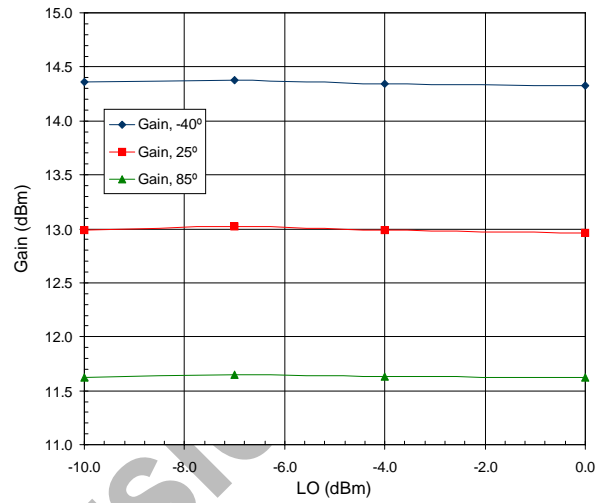

Cellular Band, Mixer FM, High Gain Mode, V_{CC}=2.7V

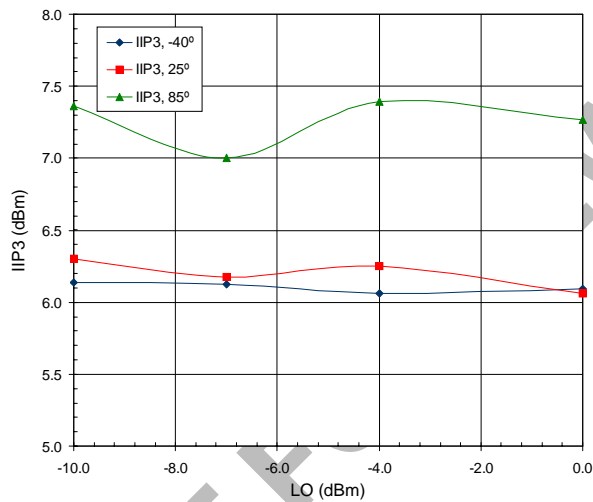

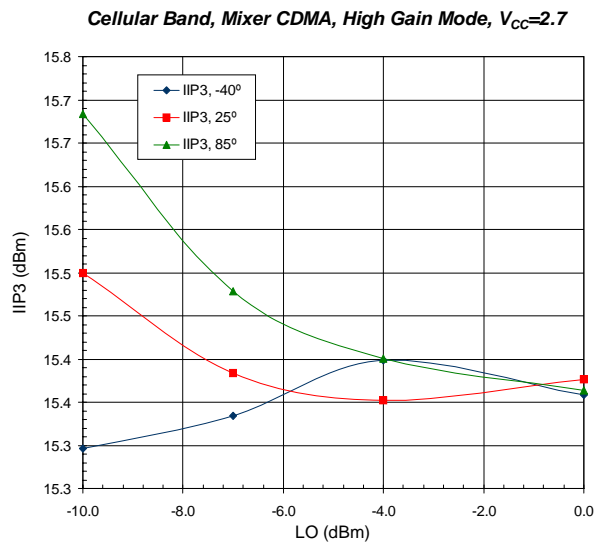
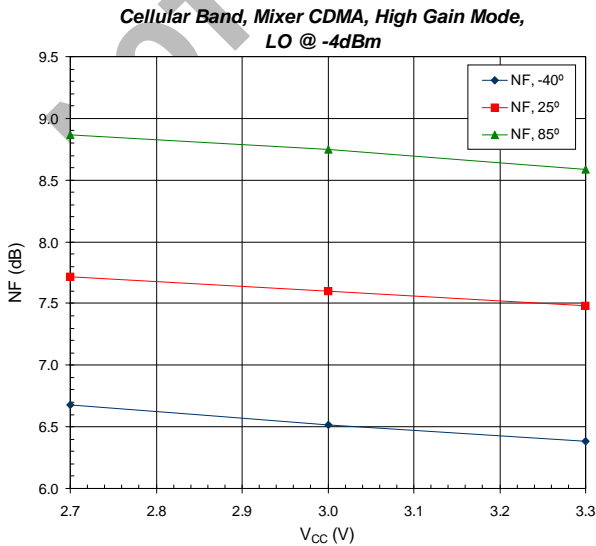
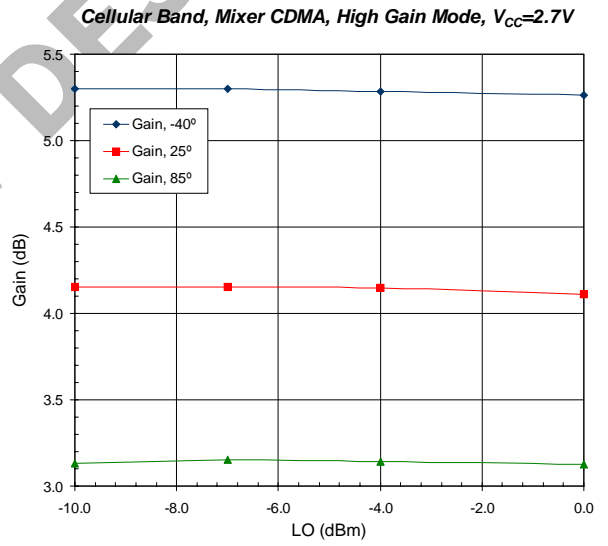
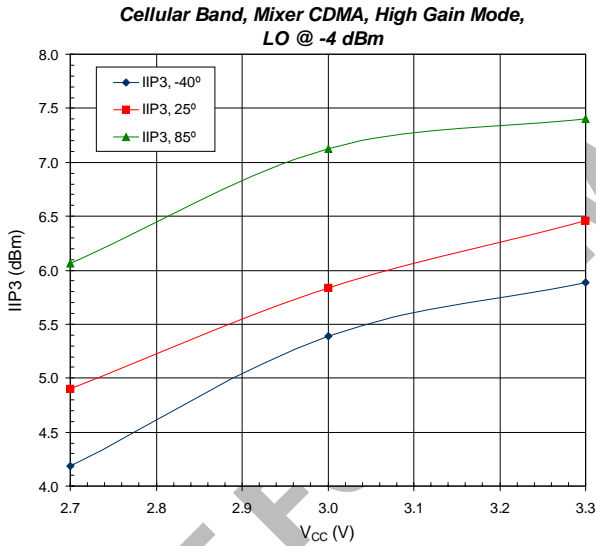
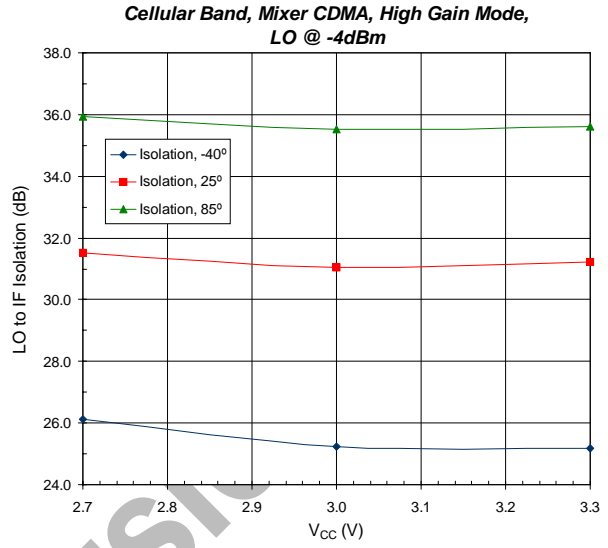
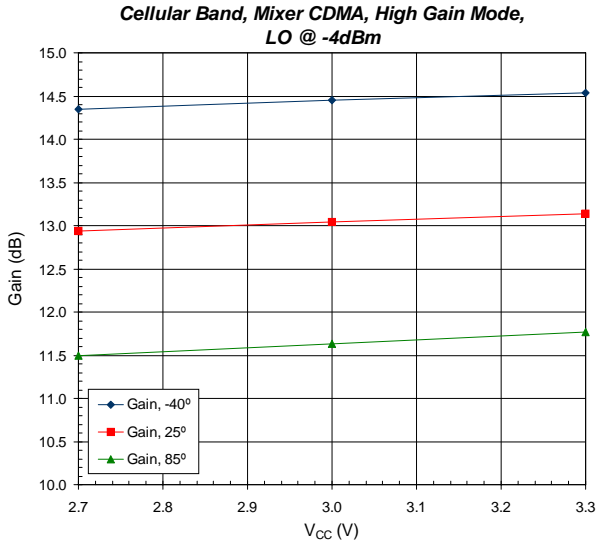

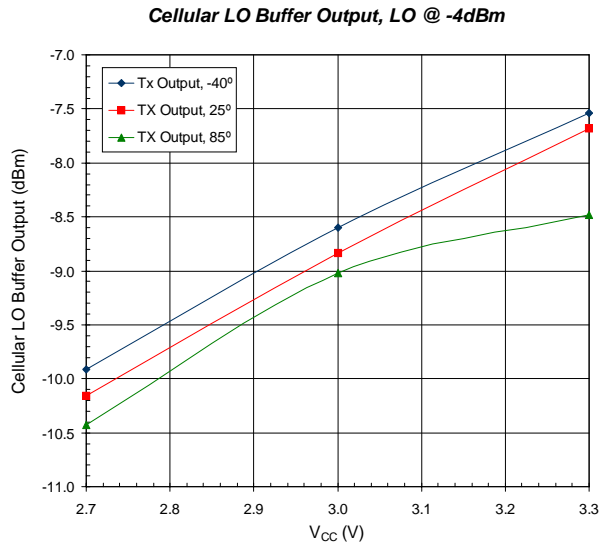

NOT FOR NEW DESIGNS

LNA PCS Mode (High Gain/Nominal IP3 Mode)

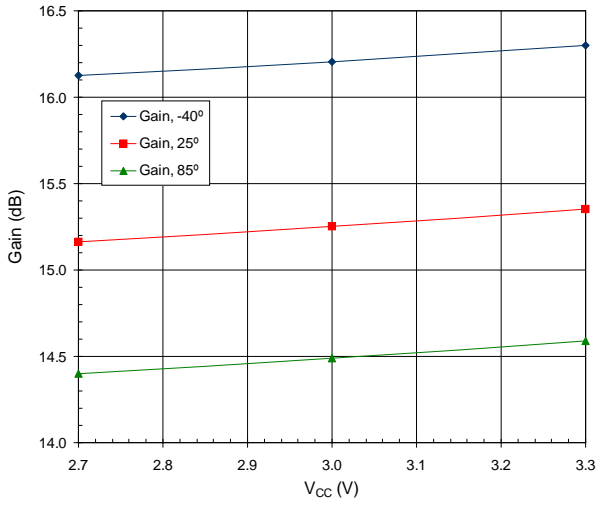

LNA PCS Mode (High Gain/Max IP3 Mode)

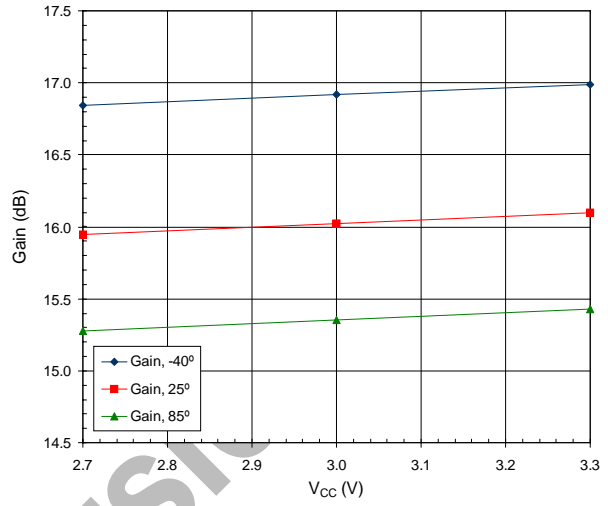

LNA PCS Mode (High Gain/Nominal IP3 Mode)

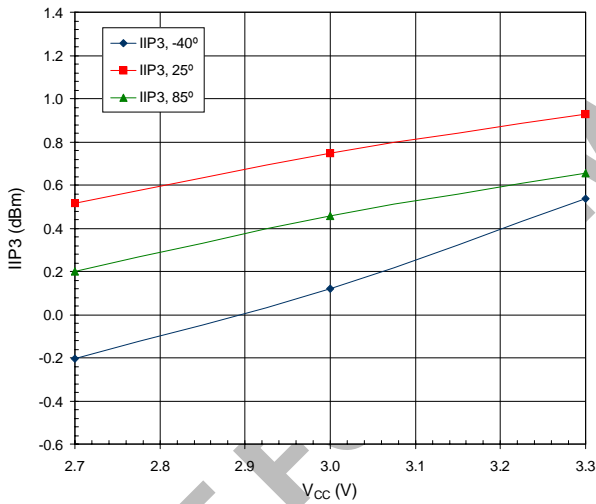

LNA PCS Mode (High Gain/Max IP3 mode)

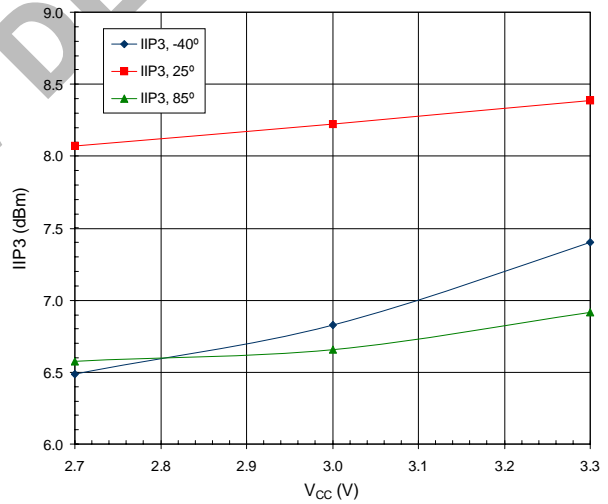

LNA PCS Mode (High Gain/Nominal IP3 Mode)

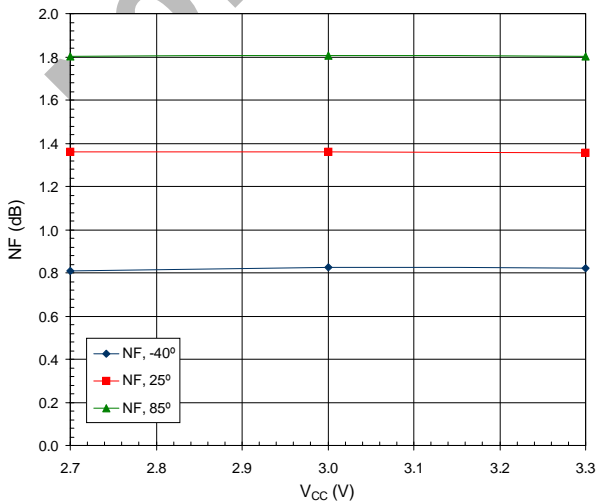

LNA PCS Mode (High Gain/Max IP3 Mode)

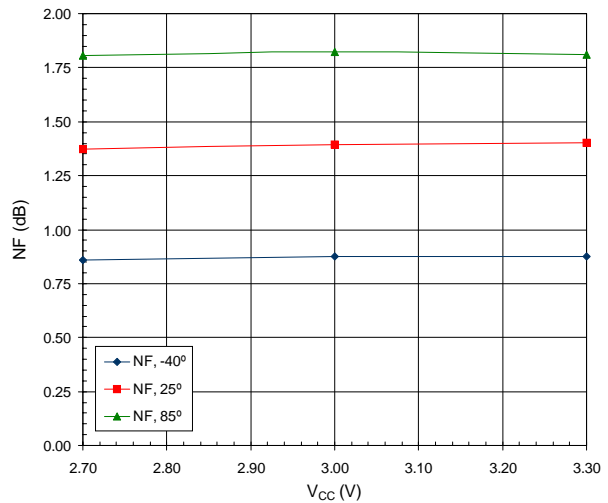

LNA PCS Band (Low Gain Mode)

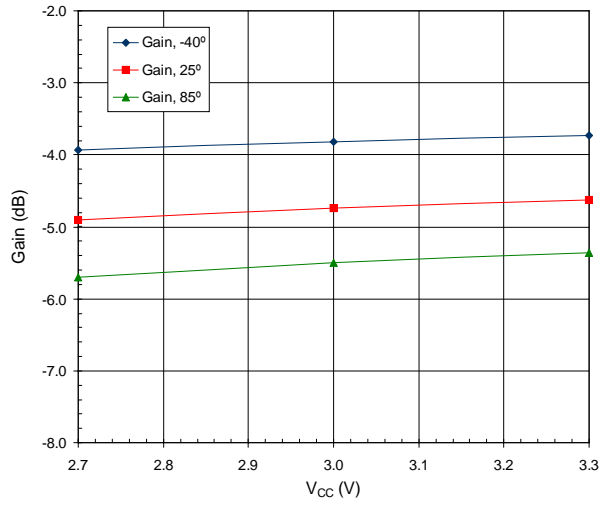

LNA PCS Mode (Low Gain Mode)

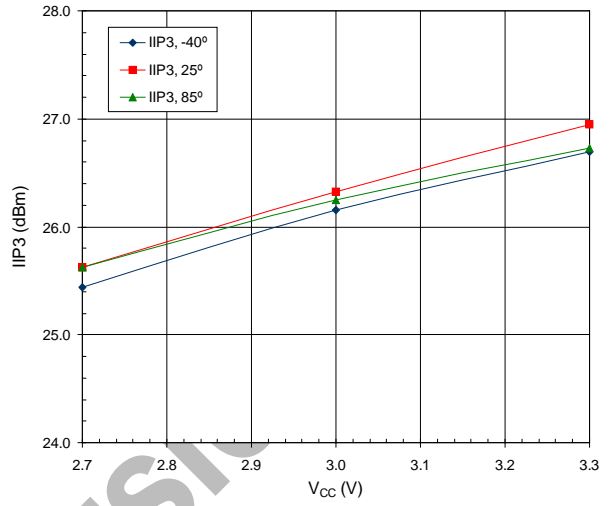

NOT FOR NEW DESIGN

PCS Band, Mixer CDMA, High Gain Mode, LO @ -4dBm

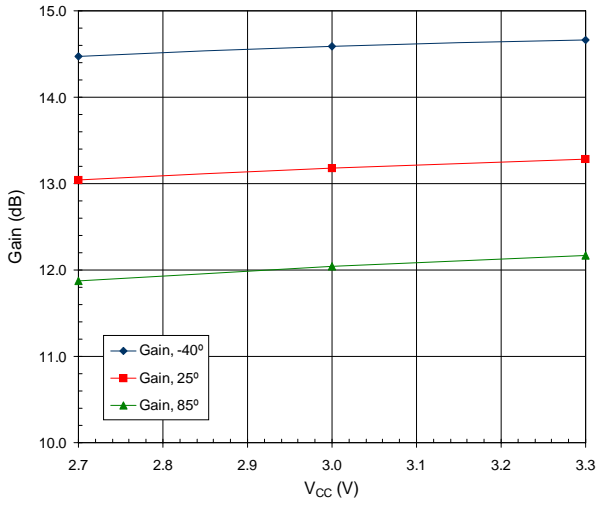

PCS Band, Mixer CDMA, Low Gain Mode, LO @ -4dBm

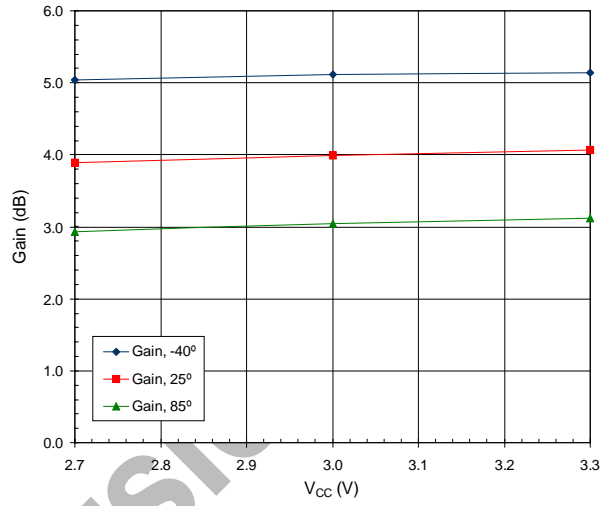

PCS Band, Mixer CDMA, High Gain Mode, LO @ -4dBm

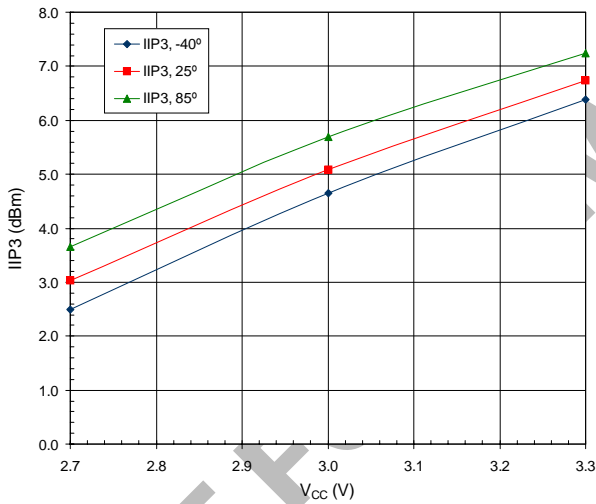

PCS Band, Mixer CDMA, Low Gain Mode, LO @ -4dBm

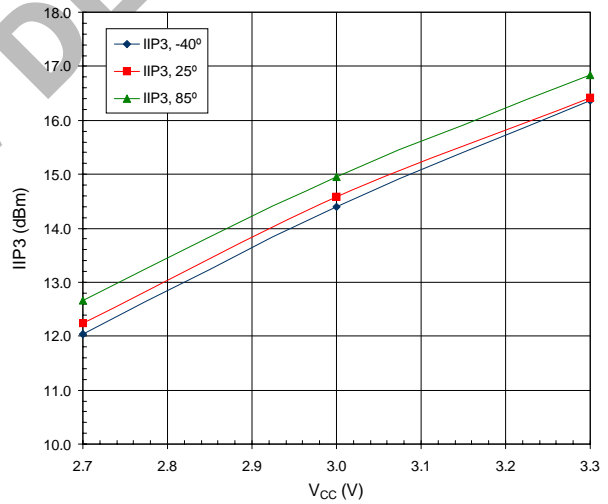

PCS Band, Mixer CDMA, High Gain Mode, LO @ -4dBm

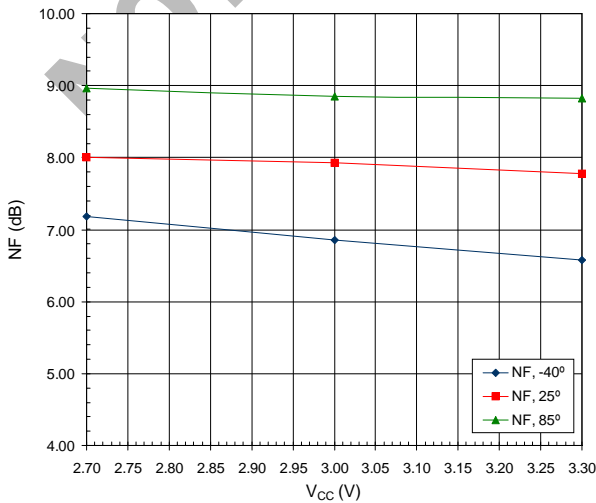

PCS Band, Mixer CDMA, Low Gain Mode, LO @ -4dBm

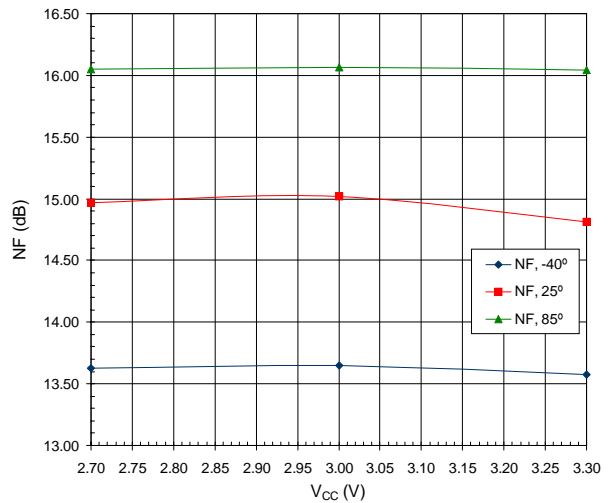

PCS Band, Mixer CDMA, High Gain Mode, LO @ -4dBm

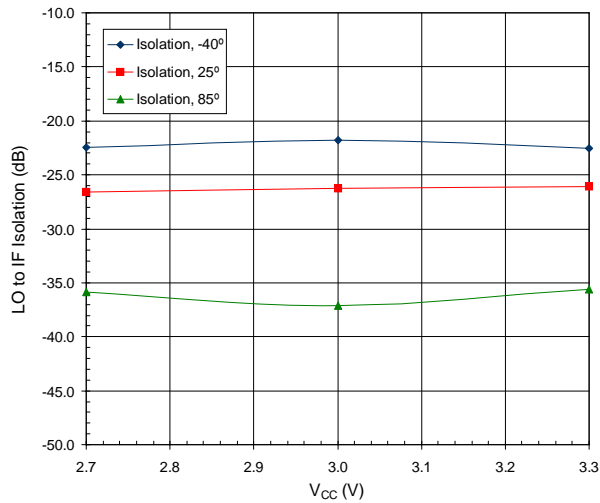

PCS Band, Mixer CDMA, High Gain Mode, V_{CC} @ 2.7V

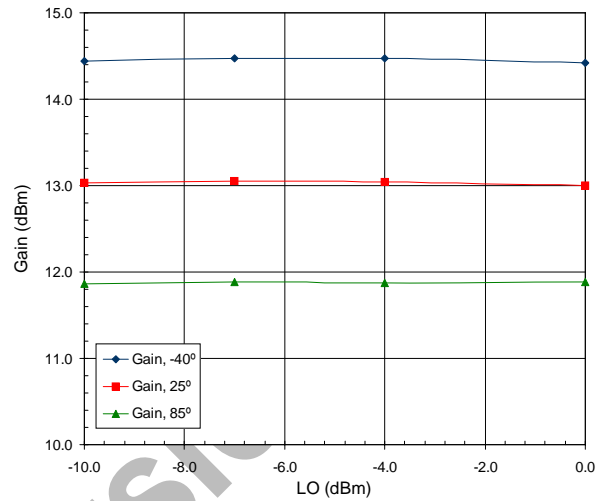

PCS Band, Mixer CDMA, High Gain Mode, V_{CC}=2.7V

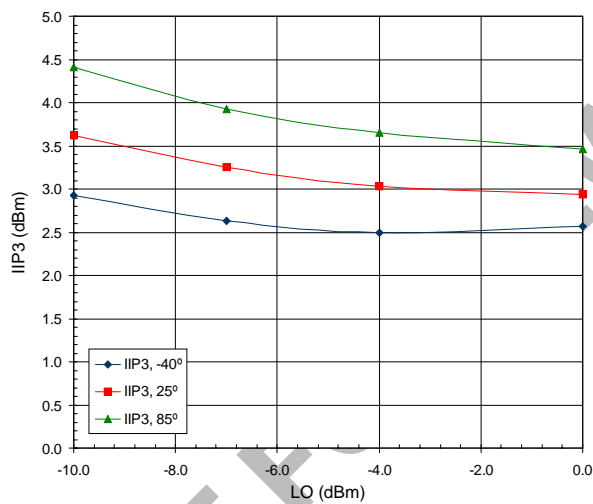

PCS LO Buffer Output, LO @ -4dBm

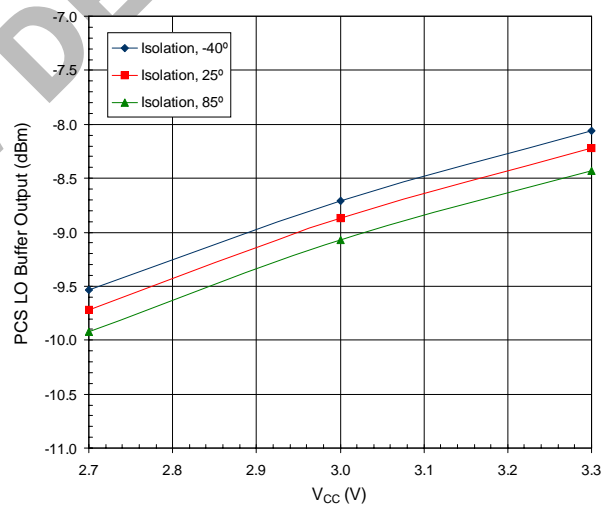

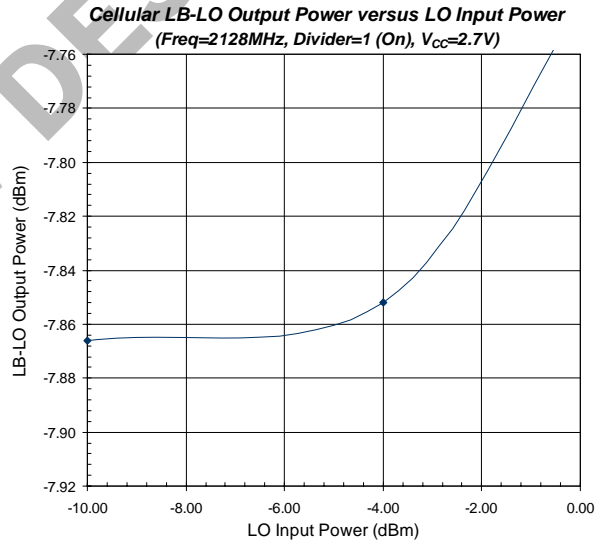
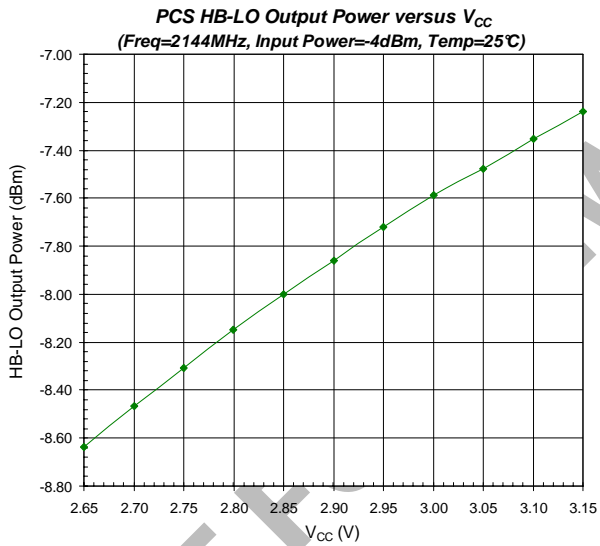
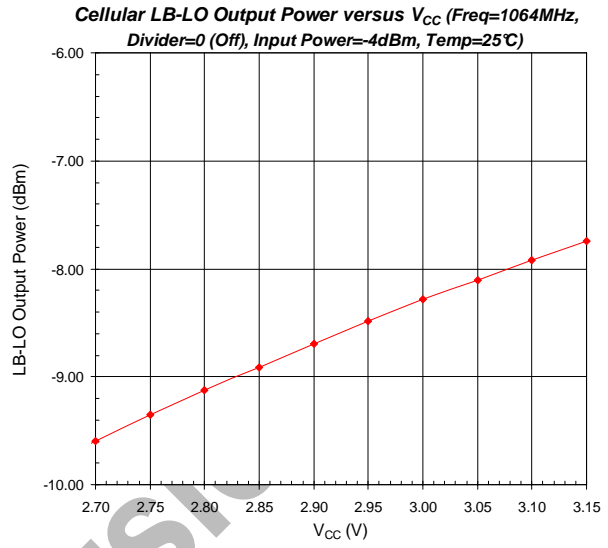
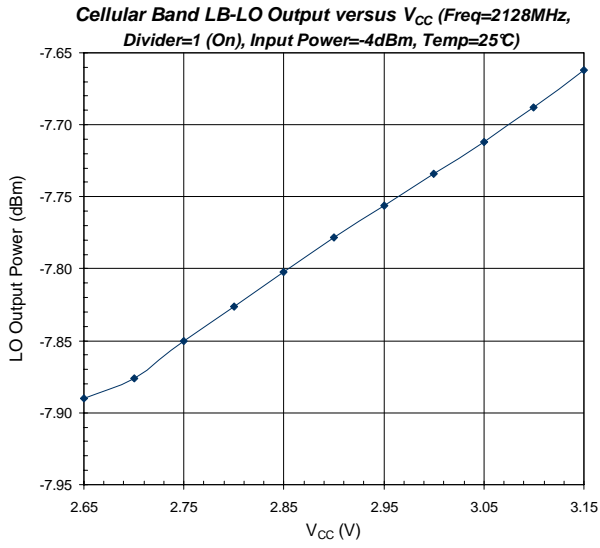

NOT FOR DESIGN

PCB Design Requirements

PCB Surface Finish

The PCB surface finish used for RFMD's qualification process is electroless nickel, immersion gold. Typical thickness is 3µinch to 8µinch gold over 180µinch nickel.

PCB Land Pattern Recommendation

PCB land patterns are based on IPC-SM-782 standards when possible. The pad pattern shown has been developed and tested for optimized assembly at RFMD; however, it may require some modifications to address company specific assembly processes. The PCB land pattern has been developed to accommodate lead and package tolerances.

PCB Metal Land Pattern

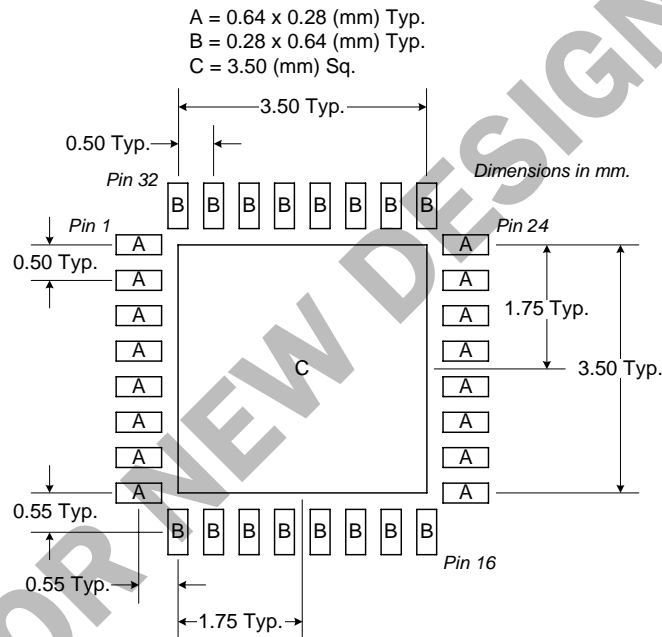

Figure 1. PCB Metal Land Pattern (Top View)

PCB Solder Mask Pattern

Liquid Photo-Imageable (LPI) solder mask is recommended. The solder mask footprint will match what is shown for the PCB metal land pattern with a 3mil expansion to accommodate solder mask registration clearance around all pads. The center-grounding pad shall also have a solder mask clearance. Expansion of the pads to create solder mask clearance can be provided in the master data or requested from the PCB fabrication supplier.

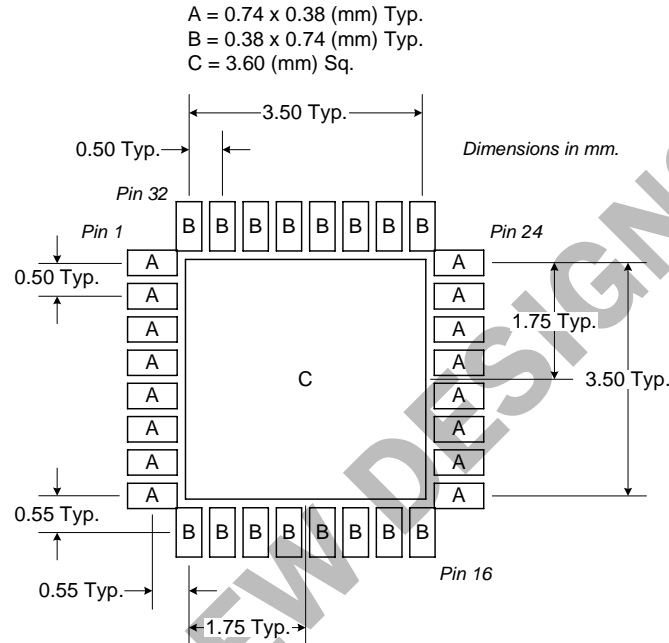

Figure 2. PCB Solder Mask Pattern (Top View)